

TUNERS / CASSETTE / DISC PLAYERS						RADIO EQ STACK
	MINI	STAN	DIN	ISO DIN	SINGLE DBL DIN	
CHASSIS H	1 3/8-2	2	2	2	3 7/8	3
CHASSIS W	7 1/8	7 1/8	7 1/8	7	7 1/8	7 1/8
CHASSIS D	4 3/4-5 1/2	5 7/8-6 11/16	5 7/8-6 11/16	5 7/8-6 11/16	5 7/8-6 11/16	5 7/8-6 11/16
NOSE H	1 5/8-1 3/4	1 5/8-1 3/4	2 3/8	1 13/16	3 3/4-4	
NOSE W	4 1/8-4 3/16	4 1/8-4 3/16	7 1/2	6 11/16	6 11/16-7 1/4	
SHAFT SP.	5 1/8-5 3/4	5 1/8-6				

### IN DASH APPLICATION NOTES

	K <sup>S</sup>	K <sup>S</sup>	K <sup>S</sup>	K <sup>S</sup>	K <sup>S</sup>	K <sup>S</sup>
--	----------------	----------------	----------------	----------------	----------------	----------------

APPLICATION KIT MODEL: FC1270, 1273, 1235 & FCJ1275

HARNESS ADAPTOR: CR01/R/AUB      ANTENNA ADAPTOR: N/A

### IN-DASH INSTALLATION AREA DIMENSIONS

	DEPTH	MAX DEPTH	WIDTH	HEIGHT	
CAVITY	7 7/8"	7 7/8"	7 7/8"	3 1/2"	
DASH OPENING	TYPE: CHRYSLER *		7 15/16"	3 3/16"	
DASH MATERIAL: PLASTIC			THICKNESS: 1/8"		
FOR MAX DEPTH		<input type="checkbox"/> REMOVE REAR SUPPORT <input type="checkbox"/> MODIFY CAVITY			

### AMPLIFIER/EQ MOUNTING LOCATIONS (WxHxD)

UNDER/IN DASH	UNDER SEAT	GLOVE BOX	TRUNK/CARGO
		14" x 3" x 6"	Various

Dimensions shown are inches.  
For inch/mm conversions refer to chart section.

UPDATED THROUGH  
'97   
'98   
'99   
'2000

# DODGE 1996-UP GRAND CARAVAN

Minivan

DASHBOARD  
Factory Provisions: 5 1/4" 2-Hole  
Aftermarket: 4" K  
K = SA1451

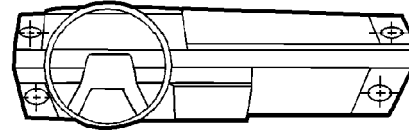

Cavity W H D  
\* x \* x 2 1/4"  
\* Speaker mounts with tabs only, in free air - no width or height to cavity.

FRONT DOORS  
Factory Provisions: 5 x 7" Infinity (deluxe) system  
Aftermarket: 5 1/8"K, 6 1/2"K, 5 x 7"  
K = SA68  
- See NOTE

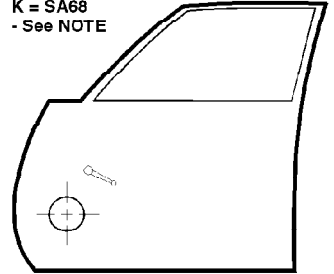

CAVITY W H D  
7 1/4" x 5" x 3"

NOTE: Must be equipped with factory speakers/adaptor to use SAU56.

REAR SIDE PANELS - VAN  
Factory Provisions: 6 x 9"  
Aftermarket: 5 1/2"K, 6 1/2"K, 6 x 9"  
K = SA69

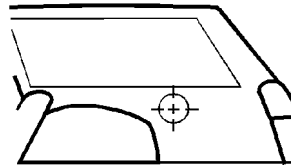

Cavity W H D  
8 7/8" x 6" x 3 3/4"

REAR CORNER PANELS - VAN  
Factory Provisions: 2 1/2" Tweeter  
Aftermarket: Tweeter K

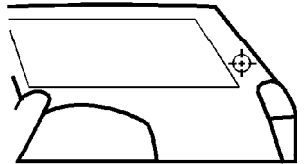

Cavity W H D  
2 1/2" x 2 1/2" x 1 1/4"

NOTE: THIS MANUAL IS BASED ON CAREFULLY DOCUMENTED RESEARCH. ABSOLUTE ACCURACY IS ATTEMPTED BUT NOT GUARANTEED. USE THIS MANUAL AS A REFERENCE GUIDE. SCOSCHE, INC. CANNOT BE RESPONSIBLE FOR INCONSISTENCIES THAT MAY OCCUR.

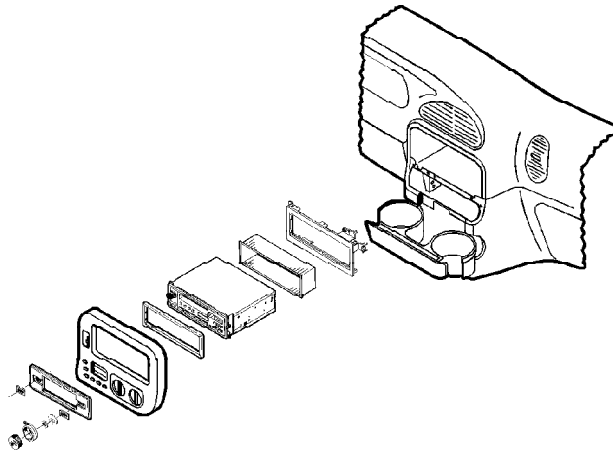

\* Note: A gap of about 3/16" exists between the factory radio and the dash piece. Scosche, Chrysler, Dodge and Plymouth installation kits include spacers to correct this problem when the kit is installed.

B = BACK UP PLATES REQUIRED.  
C<sup>1</sup> = CUT TRIM/PLASTIC (STRUCTURE).  
C<sup>2</sup> = CUT STEEL.  
D = BELOW DECK ONLY.  
D<sup>1</sup> = LIFT PORTION OF DECK. (MAY REQUIRE STRUCTURAL REINFORCEMENT).  
D<sup>2</sup> = CUT STEEL WHEN TOP MOUNTED. DO NOT IF BELOW DECK.  
D<sup>3</sup> = NARROW SURFACE, BELOW DECK ONLY.  
F<sup>1</sup> = MINIMUM MODIFICATION FILE SHAFT HOLES OR DASH OPENING.  
F<sup>2</sup> = MODIFY DASH CAVITY AND/OR PANEL.  
K = INSTALLATION KIT, SPACER OR ADAPTOR REQUIRED.  
K<sup>1</sup> = KIT MODIFICATIONS REQUIRED.  
K<sup>2</sup> = EXTENSION KIT RECOMMENDED.  
K<sup>3</sup> = WHEN EQUIPPED WITH FACTORY "ELECTRONIC" RADIO.  
K<sup>4</sup> = FABRICATE PANEL/BRACKETS.



DASH.

K<sup>S</sup> = WHEN EQUIPPED WITH STANDARD TWO SHAFT RADIO/TAPE PLAYER. FABRICATE KIT WHEN EQUIPPED WITH FLAT FACE ELECTRONIC RADIO/TAPE PLAYER.  
K<sup>S</sup> = SCOSCHE KIT RECOMMENDED.  
N = NOT RECOMMENDED. EXTENSIVE MODIFICATION REQUIRED.  
P = PERFECT WITHOUT MODIFICATION.  
P<sup>1</sup> = MODIFY OR REMOVE POCKETS.  
P<sup>2</sup> = COIN POCKET LOCATION IN DASH (MAY REQUIRE TRIM KIT).  
P<sup>3</sup> = PERFECT WHEN EQUIPPED WITH STANDARD TWO SHAFT RADIO, K WITHOUT.  
R = REAR LOAD ISOMOUNT.  
U = UNDERDASH.  
W<sup>1</sup> = WITH POWER WINDOWS ONLY.  
W<sup>2</sup> = WITHOUT POWER WINDOWS ONLY.

# 1996 DODGE GRAND CARAVAN MINIVAN



5 1/4" 2 - HOLE DASH SPEAKER.

**PRELIMINARY:** DISCONNECT THE NEGATIVE BATTERY CABLE.

**ANTENNA:** THE FACTORY ANTENNA IS LOCATED ON THE RIGHT FRONT FENDER.

## RADIO REMOVAL AND IN-DASH INSTALLATION:

**NOTE:** THE FACTORY STEREO PROVISION IS FOR A STANDARD CHRYSLER MOUNT RADIO. AN INSTALLATION KIT IS REQUIRED FOR ALL AFTERMARKET INSTALLATIONS. WE RECOMMEND THE USE OF A SCOSCHE FCJ1275, FC1270/1273, OR 1235 FOR E.Q. INSTALLATIONS.

1. EXTRACT (2) SCREWS IN THE TRIM BEZEL FROM JUST ABOVE THE RADIO. POP OUT COVER JUST ABOVE CUP HOLDER AND REMOVE (2) SCREWS FROM BEHIND.
2. PULL THE RADIO TRIM BEZEL AWAY FROM THE DASH, UNPLUG THE AC/ HEATING CONTROL.
3. EXTRACT THE (2) SCREWS SECURING THE RADIO TO THE DASH, PULL THE RADIO FROM THE CAVITY, DISCONNECT THE GROUND STRAP, UNPLUG ALL CONNECTORS AND REMOVE THE RADIO.

## FRONT DASH SPEAKER INSTALLATION:

**NOTE:** THE FACTORY SPEAKER PROVISION IS FOR A 5 1/4" 2-HOLE SPEAKER.

1. CAREFULLY PRY OUT ON THE INSIDE WINDSHIELD PLASTIC PILLAR PANELS.
2. USING A PANEL REMOVAL TOOL CAREFULLY PRY UP ON THE SPEAKER GRILLE TOP DASH PANEL, UNPLUG WARNING LIGHTS ON DRIVERS SIDE, AND LIFT UP AND AWAY FROM DASH TO REMOVE.
3. EXTRACT THE (2) SCREWS SECURING EACH SPEAKER, PULL THE SPEAKER OUT OF THE DASH, UNPLUG THE LEADS AND REMOVE.

## INFINITY (DELUXE) SOUND SYSTEM ONLY:

### FRONT DOOR SPEAKER INSTALLATION:

**NOTE (1):** THE FACTORY PROVISION IS FOR A 5" X 7" SPEAKER MOUNTED IN A STEEL ADAPTER.

**NOTE (2):** THE GRILLE STILL EXISTS IN THE DOOR PANEL FOR BASE MODELS, BUT THERE IS NO SPEAKER OR SPEAKER BRACKET IN THIS LOCATION.

1. REMOVE THE SCREW COVER AND EXTRACT THE SCREW BEHIND THE DOOR RELEASE HOUSING TRIM.
2. EXTRACT (1) SCREW FROM THE AIR FLOW AREA AT THE TOP FRONT CORNER OF THE DOOR PANEL.
3. CAREFULLY POP OUT THE POWER WINDOW/LOCK CONTROL PANEL, UNPLUG AND REMOVE.
4. EXTRACT (1) SCREW FROM BEHIND POWER WINDOW/LOCK CONTROL PANEL.
5. EXTRACT (1) SCREW FROM DOOR PANEL'S ARMREST POCKET.
6. CAREFULLY PRY OUT AROUND THE PERIMETER WITH A PANEL REMOVAL TOOL TO RELEASE THE POP FASTENERS, LIFT UP ON THE PANEL, RELEASE THE METAL ROD FROM THE DOOR OPENER AND REMOVE THE PANEL.
7. EXTRACT THE (4) SCREWS SECURING THE SPEAKER TO THE ADAPTOR, UNPLUG AND REMOVE.

## REAR SIDE PANEL SPEAKER INSTALLATION:

**NOTE:** THE FACTORY PROVISION IS FOR 6" X 9" STANDARD SPEAKERS.

1. CAREFULLY PRY OUT ON THE SPEAKER GRILLE/FABRIC PANEL WHICH RUNS ALONG THE BOTTOM OF THE REAR SIDE WINDOWS. FASTENING CLIPS WILL RELEASE AND REMOVE THE PANEL.
2. EXTRACT THE (4) SCREWS SECURING THE SPEAKER, UNPLUG THE LEADS AND REMOVE.

## INFINITY (DELUXE) SYSTEM ONLY:

### REAR PILLAR TWEETER INSTALLATION:

**NOTE (1):** THE FACTORY PROVISION IS FOR A 2 1/2" TWEETER.



FRONT DOOR PANEL.



REAR SIDE PANEL 6" X 9" SPEAKER PROVISION.



REAR CORNER PANEL 2 1/2" INFINITY TWEETER.

**NOTE (2):** THE GRILLE STILL EXISTS IN THE PANEL FOR BASE MODELS, BUT THERE IS NO SPEAKER IN THIS LOCATION.

1. USING A PANEL REMOVAL TOOL CAREFULLY PRY DOWN ON REAR (BACK) EDGE OF PLASTIC CEILING PANEL TO RELEASE THE FASTENERS AND REMOVE THE PANEL.
2. CAREFULLY POP UP BOTTOM REAR PLASTIC SILL PANEL.
3. REMOVE BOLT HOLDING UPPER REAR SHOULDER SEAT BELT SWIVEL.
4. LEFT SIDE-OPEN JACK COMPARTMENT, REMOVE JACK, AND EXTRACT (2) SCREWS.
5. PULL INWARD ON REAR PILLAR PANELS TO RELEASE SPRING CLIPS AND ACCESS TWEETERS.
6. SLIDE TWEETER OUT OF BRACKET, UNPLUG AND REMOVE.