



1.2M WORKSTATION WITH DRAWERS

MODEL NO: **AP12600.V4**

Thank you for purchasing a Sealey product. Manufactured to a high standard, this product will, if used according to these instructions, and properly maintained, give you years of trouble free performance.

IMPORTANT: PLEASE READ THESE INSTRUCTIONS CAREFULLY. NOTE THE SAFE OPERATIONAL REQUIREMENTS, WARNINGS & CAUTIONS. USE THE PRODUCT CORRECTLY AND WITH CARE FOR THE PURPOSE FOR WHICH IT IS INTENDED. FAILURE TO DO SO MAY CAUSE DAMAGE AND/OR PERSONAL INJURY AND WILL INVALIDATE THE WARRANTY. KEEP THESE INSTRUCTIONS SAFE FOR FUTURE USE.



Refer to instructions



Wear protective gloves

1. SAFETY

- WARNING!** Ensure Health & Safety, local authority, and general workshop practice regulations are adhered to when using this bench.
- Locate bench in a suitable work area.
- Keep the work area clean, uncluttered and ensure there is adequate lighting.
- WARNING!** Use bench on level and solid ground, preferably concrete.
- Keep the bench clean and tidy in accordance with good workshop practice.
- Keep children and unauthorised persons away from the work area.
- DO NOT** use the bench for any purpose other than that for which it is designed.
- DO NOT** undertake work on the bench without the workpiece being adequately secured. Use clamps or a vice (not included) to secure the workpiece - available from your Sealey Stockist.
- DO NOT** use the bench outdoors .
- DO NOT** get the bench wet or use in damp or wet locations or areas where there is condensation.
- DO NOT** exceed the maximum load for the work surfaces, worktop and bottom shelf - 100kg each, top shelf - 20kg. Avoid heavy impacts when placing objects onto the surfaces.
- DO NOT** clean the bench with any solvents which may damage the surface or the protective coating on the worktop.

2. INTRODUCTION

Boltless designed frame makes the unit easy to assemble, with minimal tools being required. Pegboard rear panel with hooks for convenient tool storage. Two half drawers, with ball bearing slides, full size shelf below MDF worktop and 230mm shelf above pegboard.

3. SPECIFICATION

Model No:	AP12600.V4
Max Capacity per level:	100Kg
Size (W x D x H [Overall/Worktop]):	1215 x 610 x 1500/900mm
Worktop size (W x D):	1205 x 600mm



4. CONTENTS

Unpack the product and check the contents against the list below. Should any items be missing or damaged contact your Sealey Stockist.

ITEM	PART NO.	DESCRIPTION	QTY
A	AP12600.V3-A	LEFT (RIGHT) FRONT POST (900MM)	2
B(L)	AP12600.V3-BL	LEFT REAR POST (966MM)	1
B(R)	AP12600.V3-BR	RIGHT REAR POST (966MM)	1
C	AP12600.V3-C	FEET	4
D	AP12600.V3-D	SIDE BEAMS (592MM)	4
E	AP12600.V3-E	BOTTOM BEAMS (1200MM)	2
E1	AP12600.V3-E1	BOTTOM TOP (1197MM)	2
F	AP12600.V3-F	FRONT & REAR SHELF BEAM (1200MM)	2
G	AP12600.V3-G	DRAW MOUNTS FRONT/REAR (135MM)	2
H(L)	AP12600.V3-HL	DRAW MOUNTS, LEFT (605MM)	1
H(R)	AP12600.V3-HR	DRAW MOUNTS, RIGHT (605MM)	1
I(L)	AP12600.V3-IL	DRAW MOUNTS, CENTRE LEFT (586MM)	1
I(R)	AP12600.V3-IR	DRAW MOUNTS, CENTRE RIGHT (586MM)	1
J	AP12600.V3-J	FRONT PANEL FOR DRAW (530MM)	2
K	AP12600.V3-K	REAR PANEL FOR DRAW (510MM)	2
L(L)	AP12600.V3-LL	LEFT SIDE PANEL FOR DRAW (455MM)	2
L(R)	AP12600.V3-LR	RIGHT SIDE PANEL FOR DRAW (455MM)	2
N(L)	AP12600.V3-NL	LEFT EXTENSION POST (610MM)	1
N(R)	AP12600.V3-NR	RIGHT EXTENSION POST (610MM)	1
O(L)	AP12600.V3-OL	LEFT TOP SHELF BEAMS (230MM)	1
O(R)	AP12600.V3-OR	RIGHT TOP SHELF BEAMS (230MM)	1
P	AP12600.V3-P	BOTTOM SHELF (1210 x 605 x 15MM)	1
Q	AP12600.V3-Q	WORKTOP (1210 x 603 x 15MM)	1
R	AP12600.V3-R	PEGBOARD (1210 x 580 x 4.5MM)	1
S	AP12600.V3-S	TOP SHELF (1205 x 228 x 6.0MM)	1
T	AP12600.V3-T	DRAW BOTTOM (512 x 450 x 6MM)	2
U	AP12600.V3-U	DRAW HANDLE	2
V	AP12600.V3-V	M4 x 10MM - Draw handle bolts (8pcs), nuts (8pcs), washers (8pcs)	24
W	AP12600.V3-W	M6 x 15MM - Fixing kit bolts (8pcs), nuts (8pcs), washers (12pcs)	28
X	AP12600.V3-XH	Toolhook	20
Y	AP12600.V4-Y	M6 x 10MM - Draw bolts (16pcs), nuts (16pcs), washers (16pcs)	48

Structural members have flat headed, waisted rivets attached which pass through keyholes in the uprights and are pushed down to secure them.

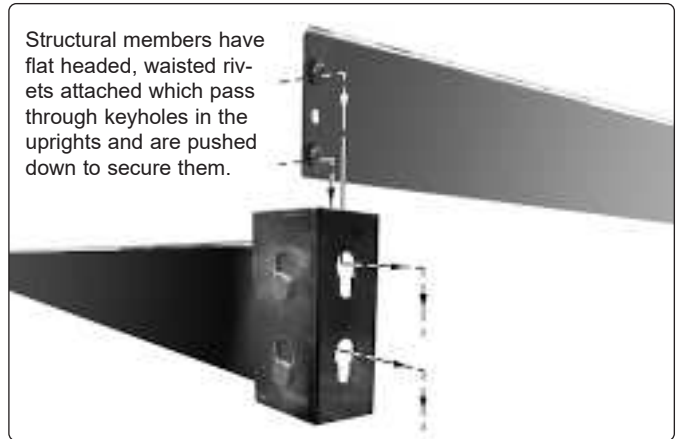

5. ASSEMBLY

- 5.1 Study each diagram and identify the components required with reference to the contents table on above.
- 5.2 Build up the basic frame as shown in diagrams 1,2,3 & 4.
- 5.3 Attach the drawer supports to the basic frame as shown in diagrams 5 & 6.
- 5.4 Bolt together the two drawers with reference to diagram 7 and fit them onto the drawer runners as shown in diagram 8.

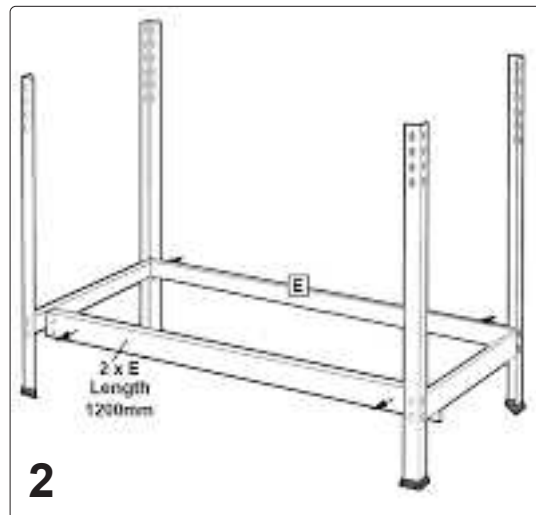
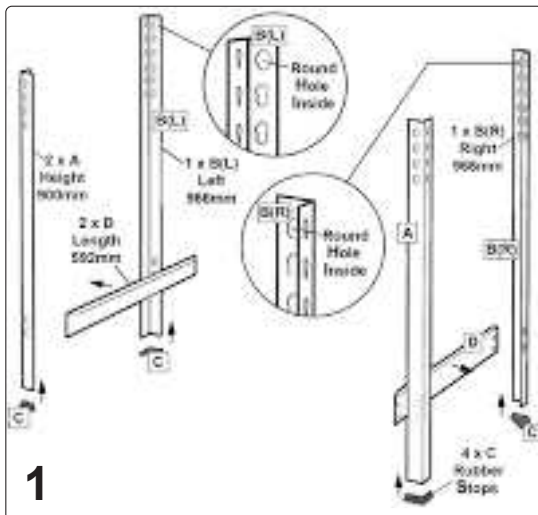

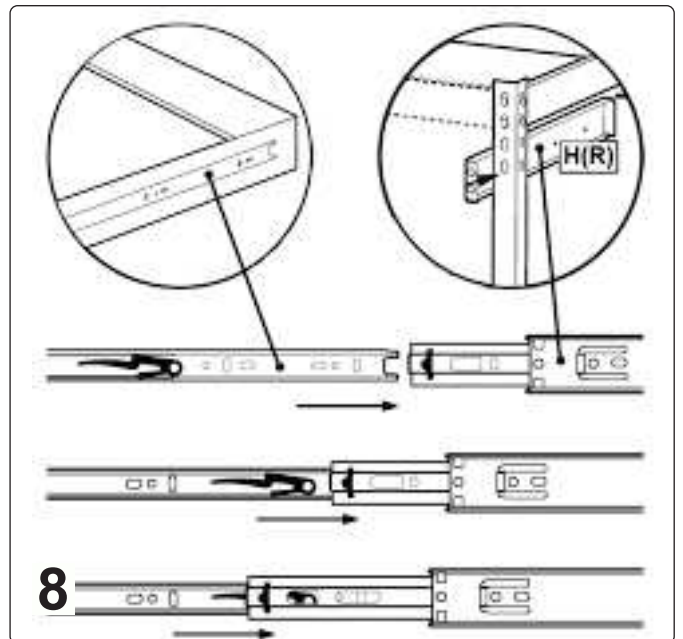
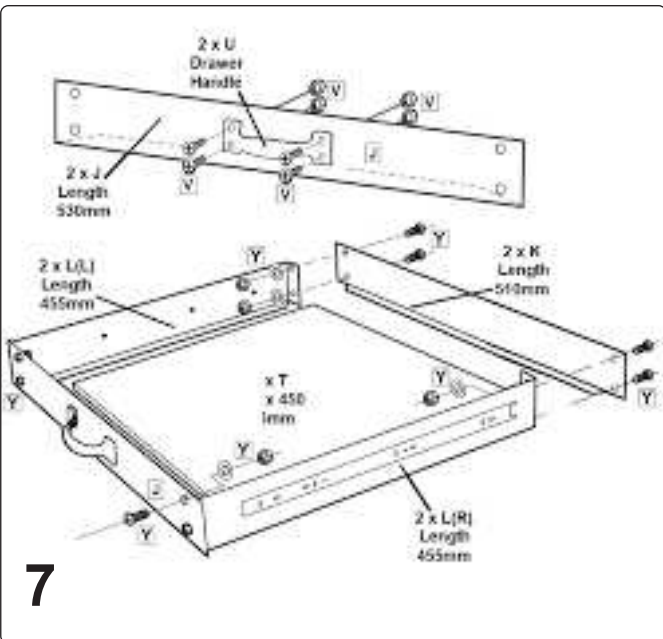
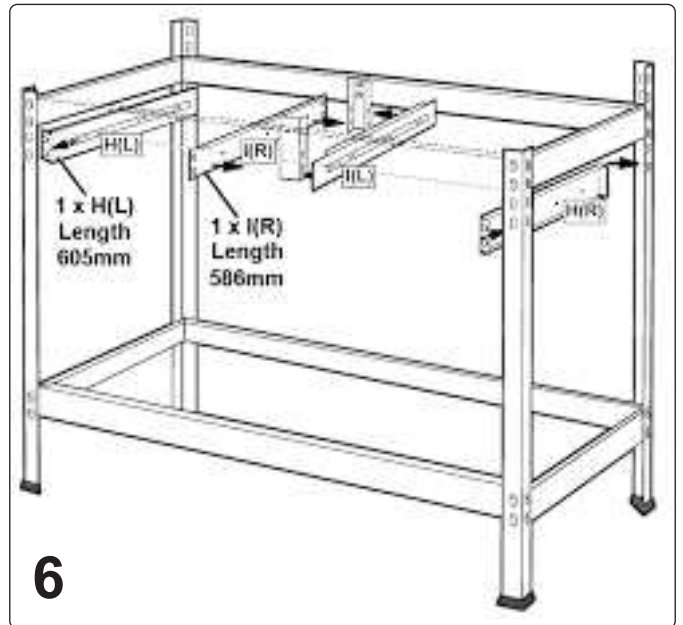
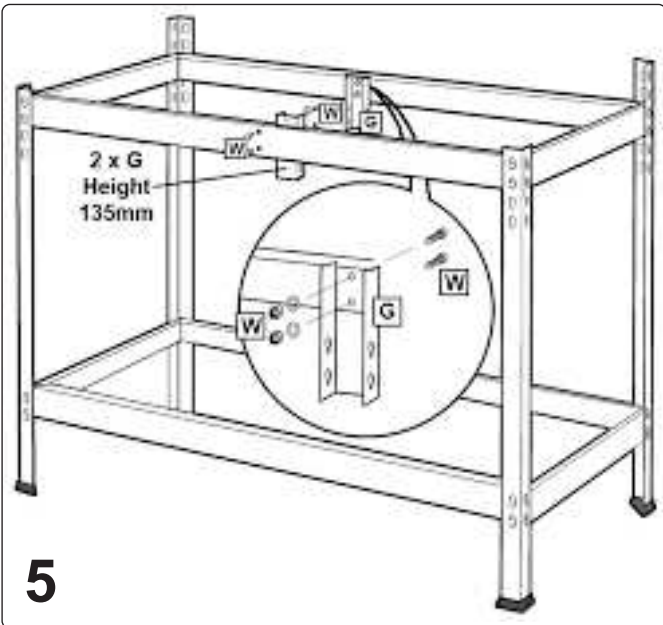
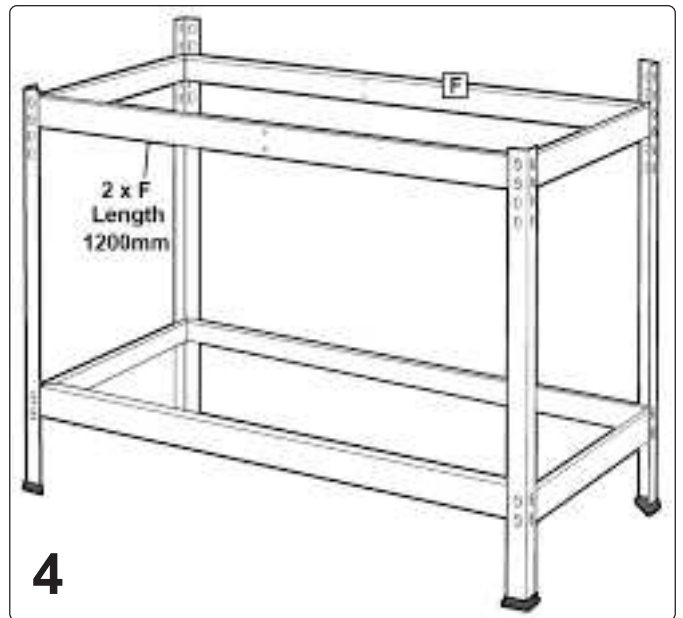
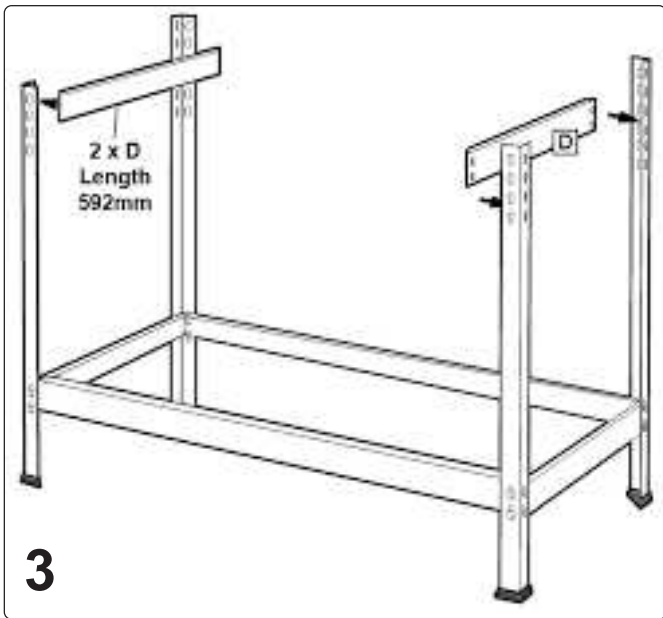

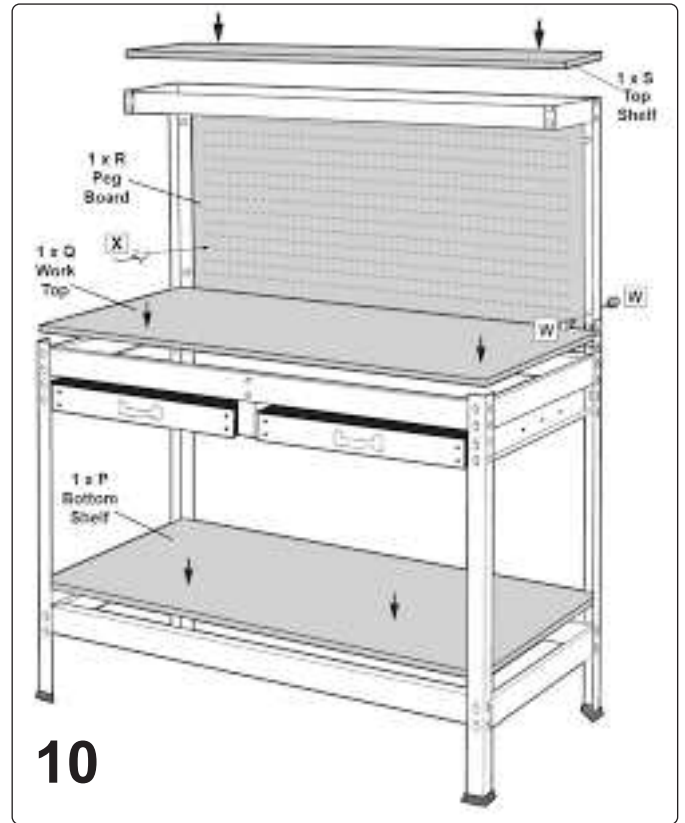
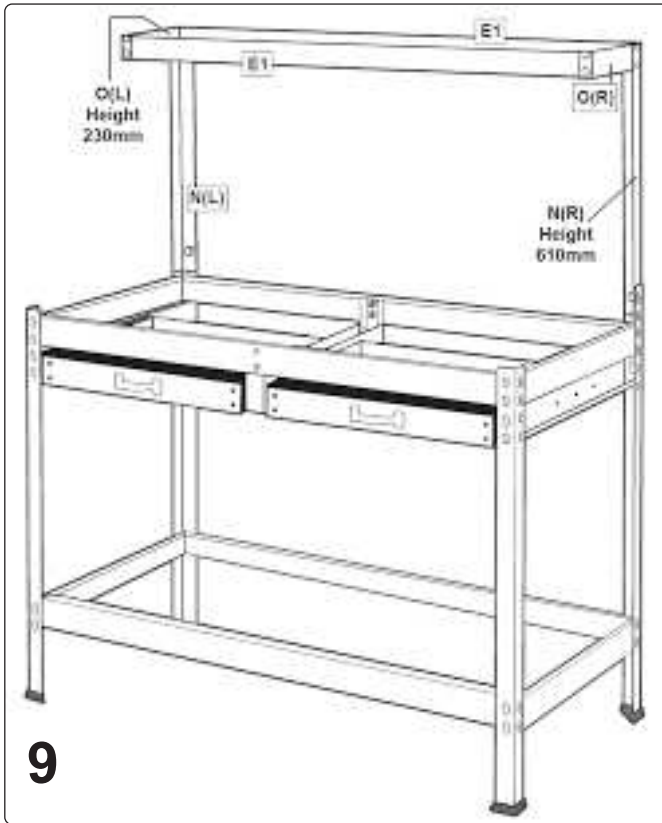

- 5.5 Attach the extension posts to the back two uprights and assemble and mount the top shelf frame as shown in diagram 9.
- 5.6 Attach the peg board to the back of the uprights and position the top shelf, work top and bottom shelf as indicated in diagram 10.
- 5.7 Attach tool hooks to peg board as required. See diagram 10.



ENVIRONMENT PROTECTION

Recycle unwanted materials instead of disposing of them as waste. All tools, accessories and packaging should be sorted, taken to a recycling centre and disposed of in a manner which is compatible with the environment. When the product becomes completely unserviceable and requires disposal, drain any fluids (if applicable) into approved containers and dispose of the product and fluids according to local regulations.



NOTE: It is our policy to continually improve products and as such we reserve the right to alter data, specifications and component parts without prior notice. Please note that other versions of this product are available. If you require documentation for alternative versions, please Email or call our technical team on technical@sealey.co.uk or 01284 757505.

IMPORTANT: No Liability is accepted for incorrect use of this product.

WARRANTY: Guarantee is 12 months from purchase date, proof of which is required for any claim.

Sealey Group, Kempson Way, Suffolk Business Park, Bury St Edmunds, Suffolk. IP32 7AR



01284 757500



sales@sealey.co.uk



www.sealey.co.uk