



DIESEL INJECTOR PULLER - FORD ECOBLUE 2.0L

MODEL NO: **VS2077**

Thank you for purchasing a Sealey product. Manufactured to a high standard, this product will, if used according to these instructions, and properly maintained, give you years of trouble free performance.

IMPORTANT: PLEASE READ THESE INSTRUCTIONS CAREFULLY. NOTE THE SAFE OPERATIONAL REQUIREMENTS, WARNINGS & CAUTIONS. USE THE PRODUCT CORRECTLY AND WITH CARE FOR THE PURPOSE FOR WHICH IT IS INTENDED. FAILURE TO DO SO MAY CAUSE DAMAGE AND/OR PERSONAL INJURY AND WILL INVALIDATE THE WARRANTY. KEEP THESE INSTRUCTIONS SAFE FOR FUTURE USE.



Refer to instructions



Wear eye protection



Wear protective Gloves



Wear Safety Footwear



Wear protective Clothing

1. SAFETY

- ❑ **WARNING!** Ensure Health and Safety, local authority and general workshop practice regulations are adhered to when using tools.
- ❑ **WARNING!** Always use caution when working around fuel systems. The fuel in the fuel rail may be pressurised even if the engine is not running.

IMPORTANT: These instructions are provided as a guide only. Always refer to the vehicle manufacturer's service instructions, or a proprietary manual, to establish the current procedure and data, also any warnings or cautions particular to the vehicle.

- × **DO NOT** use the set if any parts are missing or damaged.
- × **DO NOT** use this tool for any purpose other than that for which it is designed.
- ✓ Switch off the vehicle's ignition and disconnect the battery before commencing work under the bonnet.
- × **DO NOT** lay tools on the vehicle's battery. This may short the terminals together, causing harm to yourself, the tools, or the battery.
- ✓ Operate in a well ventilated area. **DO NOT** inhale fuel vapours.
- ✓ Wear approved eye protection. A full range of personal safety equipment is available from your Sealey stockist.
- ✓ Wear suitable clothing to avoid snagging. **DO NOT** wear jewellery and tie back long hair.
- ✓ Keep children and other unauthorised persons away from the working area.
- ✓ Keep yourself, tools, and test equipment away from hot engine parts.
- ✓ Always keep a fire extinguisher that is suitable for fuel/electrical/chemical fires close by.
- × **DO NOT** smoke or have open flames near vehicle.
- ✓ Cover fuel line fittings when connecting or disconnecting fuel lines to guard against high pressure leaks. Avoid contact with fuel.
- ✓ Clean up all fuel spills immediately and dispose of all waste according to local regulations.
- ✓ Maintain the tool components in good and clean condition for best and safest performance.
- ✓ When work on the vehicle is finished, ensure all connections on the vehicle are restored, and that there are no tools left in the engine bay.
- ✓ Replace tools in the carrying case and store in a safe, dry, childproof location.

2. INTRODUCTION

Suitable for Ford EcoBlue 2.0L engines. Designed for the extraction of seized injectors. This method of extraction will damage the injector beyond repair and will require replacement. Equivalent to OEM 303-1690, 303-1690-01.

3. CONTENTS

Item	Part No.	Description
1.	VS2077-01	Pulling Spindle
2.	VS2077-02	Support Sleeve (A)
3.	VS2077-03	Removal Socket
4.	VS2077-04	Support Sleeve (B)
5.	VS2077-05	Shoulder Nut c/w Bearing

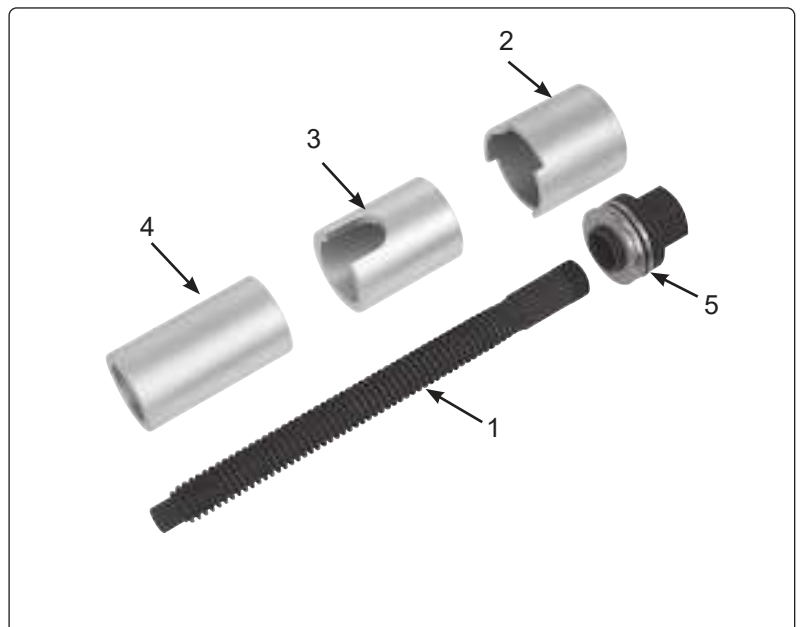

4. APPLICATIONS

FORD EcoBlue 2.0L TDCi diesel engine		
Transit 2014 onwards		
Transit Custom 2012 onwards		
Ranger 2.0L	EcoBlue Bi-Turbo Diesel:	2012.00 (04/2011)
Galaxy 2.0L	EcoBlue Bi-Turbo Diesel:	2015.50 (01/2015)
S-MAX 2.0L	EcoBlue Bi-Turbo Diesel:	2015.50 (01/2015)
Edge 2.0L	EcoBlue Bi-Turbo Diesel:	2016.00 (08/2015)
Transit 2.0L	EcoBlue Diesel	AWD, RWD:2014.50 (08/2013)
Transit 2.0L	EcoBlue Diesel	AWD, RWD:2019.75 (10/2018)
Transit 2.0L	EcoBlue Diesel	FWD: 2014.50 (08/2013)
Transit 2.0L	EcoBlue Diesel	FWD: 2019.75 (10/2018)
Ranger 2.0L	EcoBlue Diesel	2012.00 (04/2011)
Transit Custom	EcoBlue Diesel:	2012.75 (04/2012)
Mondeo 2.0L	EcoBlue Diesel:	2014.75 (10/2014)
Galaxy 2.0L	EcoBlue Diesel:	2015.50 (01/2015)
S-MAX 2.0L	EcoBlue Diesel:	2015.50 (01/2015)
Edge 2.0L	EcoBlue Diesel:	2016.00 (08/2015)
Focus 2.0L	EcoBlue Diesel:	2019.00 (01/2018)
Kuga 2.0L	EcoBlue Diesel:	2020 (07/2019)

5. OPERATION

NOTE: Ensure you have read, understood and applied the directions in the Safety section

- 5.1. Disconnect fuel and electrical connections to the injector.
- 5.2. Place Removal Socket (fig. 1.3) and using a suitable ratchet drive unscrew and withdraw the upper section of the injector.
- 5.3. Place the Pulling Spindle carefully into the remaining injector unit and screw it in until fully engaged with the injector.
- 5.4. Place the relevant Support Sleeve (fig.1.4, fig.1.2) over the spindle and slide it carefully down onto the cylinder head.
- 5.5. Screw the Shoulder Nut (fig.1.5) down to the Support Sleeve and using a suitable spanner tighten the Shoulder Nut down in order to withdraw the remainder of the injector unit.



ENVIRONMENT PROTECTION

Recycle unwanted materials instead of disposing of them as waste. All tools, accessories and packaging should be sorted, taken to a recycling centre and disposed of in a manner which is compatible with the environment. When the product becomes completely unserviceable and requires disposal, drain any fluids (if applicable) into approved containers and dispose of the product and fluids according to local regulations.

Note: It is our policy to continually improve products and as such we reserve the right to alter data, specifications and component parts without prior notice.

Important: No Liability is accepted for incorrect use of this product.

Warranty: Guarantee is 12 months from purchase date, proof of which is required for any claim.



Sealey Group, Kempson Way, Suffolk Business Park, Bury St Edmunds, Suffolk. IP32 7AR



01284 757500



sales@sealey.co.uk



www.sealey.co.uk