



AIR OPERATED COIL SPRING COMPRESSOR 1000KG

MODEL NO: **RE300.V3**

Thank you for purchasing a Sealey product. Manufactured to a high standard, this product will, if used according to these instructions, and properly maintained, give you years of trouble free performance.

IMPORTANT: PLEASE READ THESE INSTRUCTIONS CAREFULLY. NOTE THE SAFE OPERATIONAL REQUIREMENTS, WARNINGS & CAUTIONS. USE THE PRODUCT CORRECTLY AND WITH CARE FOR THE PURPOSE FOR WHICH IT IS INTENDED. FAILURE TO DO SO MAY CAUSE DAMAGE AND/OR PERSONAL INJURY AND WILL INVALIDATE THE WARRANTY. KEEP THESE INSTRUCTIONS SAFE FOR FUTURE USE.



Refer to instructions



Wear eye protection



Wear protective gloves



Beware coil binding

1. SAFETY

1.1. GENERAL SAFETY

- WARNING!** Ensure Health & Safety, local authority, and general workshop practice regulations are adhered to when using this equipment.
- ✓ The user shall work in accordance with the instruction handbook.
- ✓ The operator shall be provided with all necessary information about training and about pumping and translating forces.
- WARNING!** Wear approved safety hand and eye protection (standard spectacles are not adequate).
- WARNING! TRAPPING DANGER** – Keep hands and fingers away from the spring and compressing jaws in use.
- ✓ Keep the work area clean, uncluttered and ensure there is adequate lighting.
- ✓ Maintain correct balance and footing. Ensure the floor is not slippery and wear non-slip shoes.
- ✓ Remove ill-fitting clothes. Remove ties, watches, rings, other loose jewellery. Contain and/or tie back long hair.
- ✓ Wear appropriate protective clothing.
- ✓ Familiarise yourself with the applications, limitations and potential hazards of the spring compressor.
- ✗ **DO NOT** use the spring compressor for a task it was not designed to perform.
- ✗ **DO NOT** allow untrained persons to use the spring compressor.

1.2. PRE-OPERATIONAL SAFETY

- ✓ Apply a little transmission oil to the front and rear faces of the main upright to assist the smooth action of the compressor.
- ✗ **DO NOT** operate compressor if parts are damaged or missing as this may cause failure and/or personal injury.
- ✓ Before commencing compression, make a visual inspection of machine to ensure pins are securely positioned and that there is no sign of wear or fatigue – if found, **DO NOT** use and refer to your local Sealey stockist for advice and replacement parts.
- ✓ Ensure jaw locating pins are properly positioned and safety clips are attached correctly.
- ✓ Before commencing compression of spring, ensure coils of the spring are seated securely in the yokes of the compressor and cannot slide out during compression.
- ✓ **ALWAYS** ensure that the safety guard locks in place, use the chain to secure the spring safely and attach the gate safety chain.

1.3. OPERATIONAL SAFETY

- ✓ When applying compression to the spring, always stand to one side of the compressor.
- ▲ **DANGER!** Stop compressing the spring before the coils touch / bind.
- ▲ **DANGER!** Before attempting to remove top cap nut, always use a tool or similar to test if the compression has been relieved, **DO NOT** use your hands / fingers.
- ✓ We recommend the use of purpose made strut tools to remove the top-nut from the shock piston.
- ✓ Once compressed, and the strut removed, we recommend releasing the tension on the spring. **DO NOT** leave the spring under compression in the machine unattended and **DO NOT** leave in compression for prolonged periods, i.e. overnight.
- ✓ Before releasing the compression ensure that the top strut-nut is securely tightened to the manufacturer's tolerance.
- ✓ Release the compression slowly keeping your hands and fingers away from the spring assembly.
- ✓ Be sure that the tension on the spring is fully controlled by the strut assembly before removing it from the yokes of the compressor.
- WARNING!** In the event of accident or breakdown stop compressing and if safe to do so, release compression on spring.
- ✓ Check the condition of the markings. Markings must remain as they initially are at point of sale.

1.4. POST OPERATIONAL SAFETY

- ✓ When not in use, clean and store the spring compressor in a safe, dry, childproof location.
- ✓ Maintain the spring compressor in good condition. Replace or repair damaged parts. Use genuine parts only.
- ✓ Unauthorised parts may be dangerous and will invalidate the warranty.

2. INTRODUCTION

Designed for fast and safe compression of road springs. 1000kg Air operated unit with safety locking guard. Supplied with two interchangeable plastic coated lower yokes and a suspension strut clamp. Fits a wide range of spring configurations and diameters. Also features a strut locating platform for easy movement of the suspension strut to avoid unnecessary lifting.

3. SPECIFICATION

Model no.RE300.V3
 Maximum Load..... 1000kg
 Upper Yoke Travel..... 420mm
 Spring Diameter 102-165mm
 Actuation..... Foot Pedal

Weight..... 63.4kg
 Dimensions (W x D x H):..... 480 x 520 x 1038mm
 Maximum Air pressure 116psi(8bar)



4. FEATURES

- 1: Safety Locking Guard
- 2: Hook Assembly
- 3: Moving Arm
- 4: Lower Yoke Small
- 5: Lower Yoke Large
- 6: Lower Strut Clamp
- 7: Chain A
- 8: Locating Plate
- 9: Foot pedal

5. ASSEMBLY

Numbers refer to attached Parts Diagram.

NOTE: Parts List refers to letters: A, B, C, D, E, F and G.

Use the pairs of letters to show where sub assemblies are fitted.

- 5.1. Unpack the spring compressor carefully, it will be necessary for two people to do this.
- 5.2. Lay out all of the parts ready for assembly.
- 5.3. Assemble the spring compressor as follows:
- 5.4. **FEET:** There is a pre-drilled hole in each foot, if the unit needs to be bolted to the floor permanently, fig1.2.
 - 5.4.1. Fit the two feet to the bottom of the frame with the wheels facing rearwards. Use four cap bolts, flat washers, spring washers and domed nuts, to secure in place.

NOTE: the one longer bolt is fitted in position as shown in fig.1.
 - 5.4.2. Using two people, stand the unit onto its feet, taking care when the wheels come into contact with the floor as the unit's weight might become unstable.
- 5.5. **GUARD LOCK ASSEMBLY (part K21)** Fit to the front of the unit using four cross headed bolts, see Parts List for positioning.
- 5.6. **SAFETY LOCKING GUARD (K44)** See **E positions on Parts List:** Fit guard by dropping it onto the bottom pivot, and then fit the large pin (K11), flat washer (K46), spring (K45) into the top pivot holes and secure using a washer (K7), spring washer (K56) and domed nut (K56).

Some pressure will be needed to push down on the pin to allow the nut to be fitted.
- 5.7. **CHAIN: (part K15)** Fit to the left hand side using bolt (K14), washer (K7) and nut (K23) to fix in place.
 - 5.7.1. Remove the clip from the end of the chain and clip it onto the hook on the other side of the compressor frame, the chain can then be fixed to the clip at the appropriate link as required (fig.2).
 - 5.7.2. **LOCATING PLATE (part K42)** See **position F on Parts List:** Thread onto the long metal rod (part K41) and secure by fitting and tightening knob (part B08).

The top of the rod fits through the hole in the frame and is held in place using a domed nut and washer.

The bottom of the rod is secured by attaching the connecting rod (K43) to it and securing with a nut.

Refer to position G on Parts List: Then undo the domed nut previously fitted (fig.1), and fit the metal arm over the bolt and refit the domed nut.
- 5.8. **HANDLE (K1):** Fit the handle (K1) to the top of the unit using two domed nuts (K5), washers (K7) and spring washers (K6) to secure in place.
- 5.9. **YOKES (K12, K13, K24):** Hang two of the yokes not being used to the sides of the frame and locate the third yoke onto the compressor using the locking pin to hold it in position (fig.6).
- 5.10. **AIR HOSES:** Hoses and their connected position are labelled 'A', 'B' and 'C'. Insert hoses into correct locations.
 - 5.10.1. Position the unit in a suitable location near an air line feed.

6. PREPARATION

- WARNING!** Ensure the air supply is always clean and does not exceed 116psi (8bar) whilst operating the compressor. Too high an air pressure and unclean air will shorten the product life due to excessive wear, and may be dangerous causing damage and/or personal injury.
- 6.1. A maximum air pressure of 116psi (8bar) is required to operate at full capacity.
- 6.2. Ensure foot control lever is in the 'Off' position before connecting to the air supply.
- 6.3. Drain the air supply water separator daily to avoid water in the air line which may damage the ram.
- 6.4. **WORK AREA:** Spring compressor must be sited in an area that allows enough space to safely operate it.

7. OPERATION

- 7.1. **COMPRESSING A STRUT SPRING**

NOTE! Before removing the strut from the vehicle it is recommended that the upper strut locking plate nut is loosened a quarter turn.

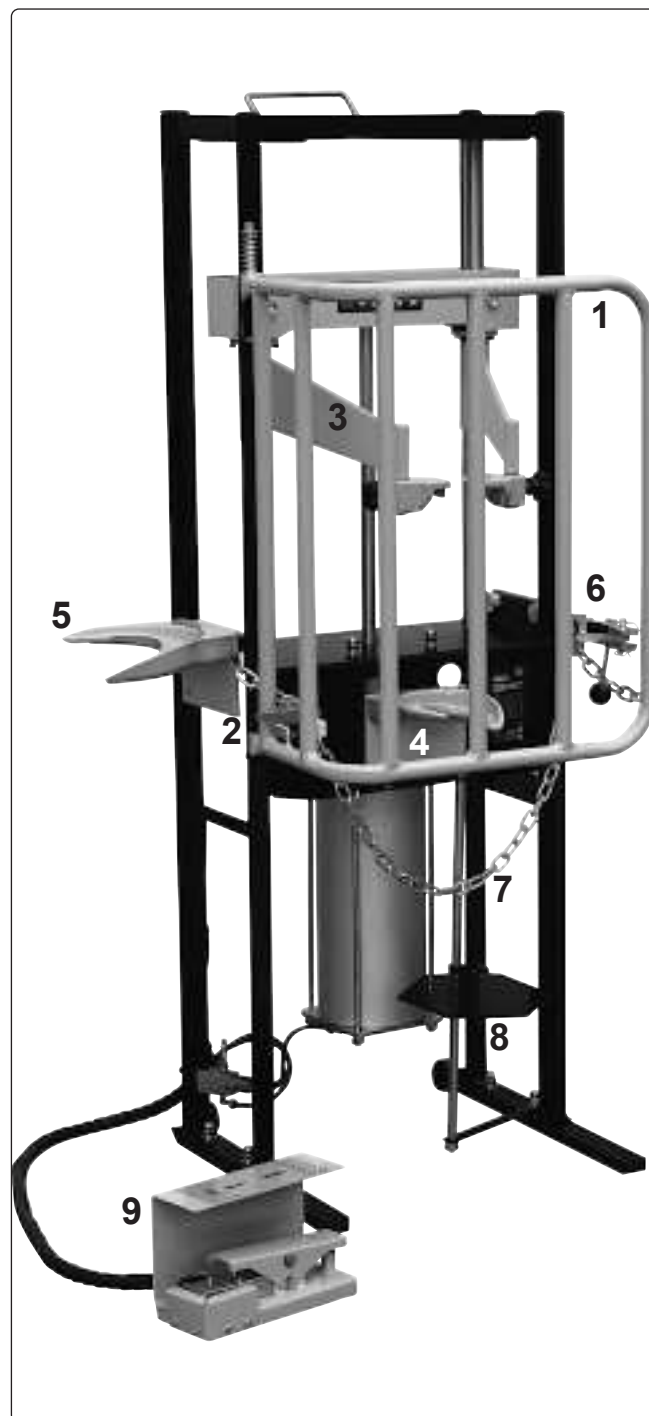

DO NOT loosen more than a quarter turn.

- 7.1.1. With the strut and spring removed from the vehicle, select the most suitably sized yoke or the strut clamp (parts K12, K13, 24) according to the size of the spring and fit it onto the compressor using the locking pin to hold it in position (fig.3).
- 7.1.2. Position the lowest coil of the spring in the lower yoke and rotate the strut and spring so that the coil is held as low as possible (fig.4).
- 7.1.3. Swing the upper arms (parts K51) into position and locate the upper clamps on the uppermost available coil (fig.5). Ensure that the coil is placed inside the recesses of the clamp to ensure that the coil will not break free under compression.
- 7.1.4. Having correctly positioned the spring on the lower and upper yokes, tighten both of the locking knobs (fig.6).
- 7.1.5. Position the locating plate (K42) so that it is just underneath the bottom of the strut and secure it in place.
- 7.1.6. Use the chain (part K15) to secure the spring by coiling through the spring and hooking it onto the clip (fig.4).
- 7.1.7. Shut the safety guard ensuring that it locks in place (fig.2). Use the end of the chain to lock the guard in place (fig.7).

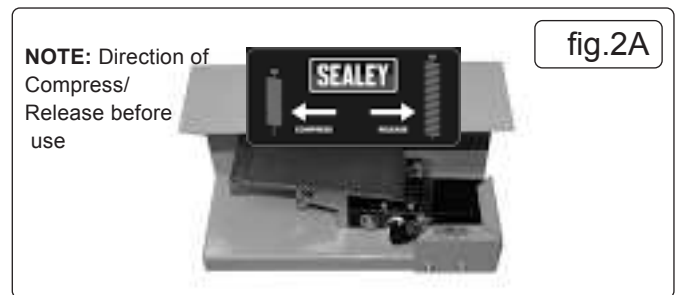
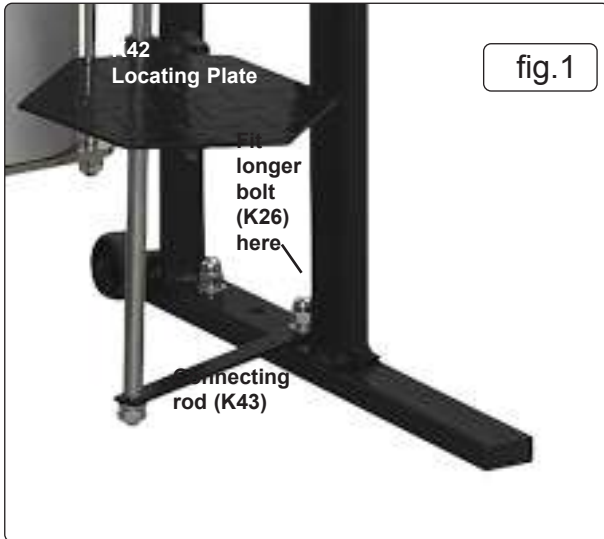

- ▲ **DANGER!** Stop compressing the spring before the coil windings touch/bind.
- **WARNING!** If the spring/strut is not located correctly in the jaws, it is possible that the strut top retaining cap could be subject to sideways forces. Watch closely as the spring reaches it's final phase of compression and ensure the top cap assembly rotates freely before attempting to remove it.
- **WARNING!** Keep hands away from the spring whilst compressing.

- 7.1.8. Check to make sure that the spring is safely secured and then gradually press the pedal, refer to fig.2A, to start to compress the spring coils. Ensure the spring is securely held.
- 7.1.9. When the strut is loose within the spring, unscrew the strut top plate nut and remove the plate from the top of the strut. Gradually discharge the pressure on the spring by operating the foot control pedal. When all the pressure has been released, take care to support the strut and spring when they become loose. Move the locating plate and withdraw the strut from the compressor. Release the spring from the upper retaining clamps and remove from the compressor.

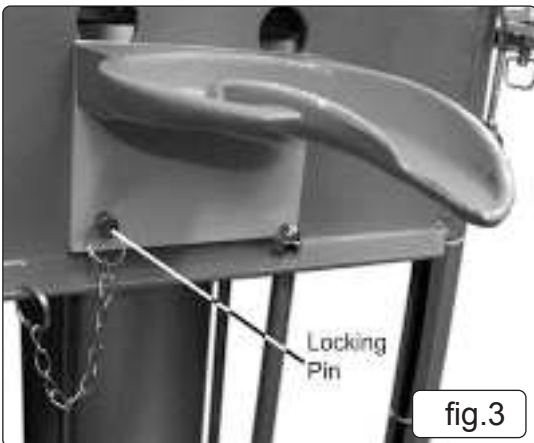

7.2. FITTING A STRUT SPRING

- 7.2.1. Offer the new strut spring up to the compressor's yokes and fit it in the same position as that of the old spring. Position the lowest coil of the spring in the lower yoke and rotate the spring, so that the coil is held as low as possible. Swing the small upper arms into position and locate the upper clamps on the uppermost available coil. Ensure that the coil is placed inside the recesses of the yokes to ensure that the coil will not break free under compression. Tighten the locking knobs (fig.6).
NOTE: There must be coils free at either end to allow them to seat on the strut plates, without the strut and compressor yokes interfering.
- 7.2.2. Insert the strut up inside the spring, and move the locating plate (K42) just underneath the bottom of the strut to support it and secure the plate in place by tightening the knob.
- 7.2.3. Use the chain to secure the spring by pulling it across and hooking it onto the side frame clip. Shut the safety guard, ensuring that it locks in place and fit safety chain through a coil of the spring and around safety guard, refer to 7.17. above and (fig.7).
- ▲ **DANGER!** Stop compressing the spring before the coil windings touch or bind.
- 7.3. **EMERGENCY STOP PROCEDURE:** Stop pressing the compress pedal in an emergency situation.
- **WARNING!** Keep hands away from spring.

- 7.3.1. Compress the spring using the correct pedal on the foot control unit, ensuring that the spring is securely held in place within the clamp recesses at all times. When the spring is compressed sufficiently, fit the strut top plate to the strut, and using a new nut, secure it in position.
- 7.3.2. Decompress the spring carefully and slowly, using the pedal on the foot control unit, ensuring the spring is located correctly into the strut top plate.

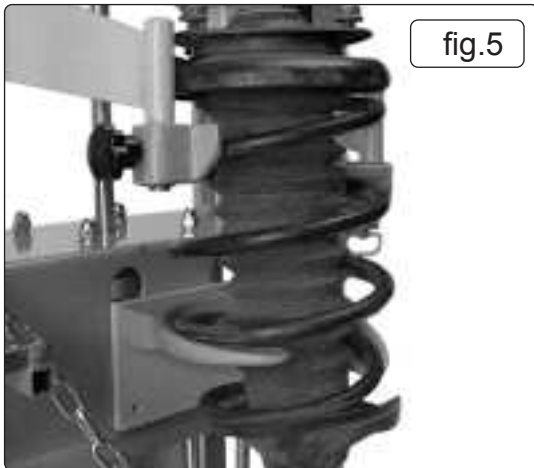

fig.5



fig.6

- 7.3.3. Remove complete strut carefully from the spring compressor.
- 7.3.4. When re-fitting the strut to the vehicle, the locking plate nut will need to be fully tightened using a torque wrench, to a setting in accordance with the vehicle manufacturer's specification.

8. MAINTENANCE

- 8.1. Remove from air supply before performing Maintenance and select a safe, clear location to carry it out.
- 8.2. Before each use, check the spring compressor to ensure it is not damaged or worn. If in any doubt **DO NOT** use the spring compressor. Remove it from service immediately and contact your local Sealey stockist for advice and/or repairs.
- 8.3. Periodically clean the sliding columns and wipe over using a little transmission oil.
- 8.4. Any other maintenance required should be carried out by an authorised service agent.
- 8.5. If the spring compressor is not being used for a considerable length of time, disconnect the air supply and discharge any air in the cylinder by depressing the foot control lever. Drop a little Sealey air tool oil into the air inlet and cover to prevent the ingress of any foreign matter.
- 8.6. **STORAGE:**
Store in a safe, dry location.

9. END OF LIFE

- 9.1. Dismantle the product and recycle as per local regulations in force.



fig.7

NOTE 1: Chain is looped around a spring coil.

NOTE 2:
End of chain loops around safety locking guard.



ENVIRONMENT PROTECTION

Recycle unwanted materials instead of disposing of them as waste. All tools, accessories and packaging should be sorted, taken to a recycling centre and disposed of in a manner which is compatible with the environment. When the product becomes completely unserviceable and requires disposal, drain any fluids (if applicable) into approved containers and dispose of the product and fluids according to local regulations.



Note: It is our policy to continually improve products and as such we reserve the right to alter data, specifications and component parts without prior notice. Please note that other versions of this product are available. If you require documentation for alternative versions, please email or call our technical team on technical@sealey.co.uk or 01284 757505.

Important: No Liability is accepted for incorrect use of this product.

Warranty: Guarantee is 12 months from purchase date, proof of which is required for any claim.

Sealey Group, Kempson Way, Suffolk Business Park, Bury St Edmunds, Suffolk. IP32 7AR

01284 757500

sales@sealey.co.uk

www.sealey.co.uk