



INSTRUCTIONS FOR

SUPERBOOST STARTER / CHARGER

MODEL NOS: SUPERBOOST 140.V4 & SUPERBOOST 160.V5

Thank you for purchasing a Sealey product. Manufactured to a high standard, this product will, if used according to these instructions, and properly maintained, give you years of trouble free performance.

IMPORTANT: PLEASE READ THESE INSTRUCTIONS CAREFULLY. NOTE THE SAFE OPERATIONAL REQUIREMENTS, WARNINGS & CAUTIONS. USE THE PRODUCT CORRECTLY AND WITH CARE FOR THE PURPOSE FOR WHICH IT IS INTENDED. FAILURE TO DO SO MAY CAUSE DAMAGE AND/OR PERSONAL INJURY AND WILL INVALIDATE THE WARRANTY. KEEP THESE INSTRUCTIONS SAFE FOR FUTURE USE.



Refer to instruction manual



Warning: explosive materials



Wear eye protection



Warning: corrosive substance



Wear protective gloves



Warning: electricity



Protect from rain



Use in well ventilated areas



Keep away from sources of ignition: battery could explode

1. SAFETY

1.1. ELECTRICAL SAFETY

- ❑ **WARNING!** It is the responsibility of the owner and the operator to read, understand and comply with the following:
You must check all electrical products, before use, to ensure that they are safe. You must inspect power cables, plugs, sockets and any other connectors for wear or damage. You must ensure that the risk of electric shock is minimised by the installation of appropriate safety devices. A Residual Current Circuit Breaker (RCCB) should be incorporated in the main distribution board. We also recommend that a Residual Current Device (RCD) is used. It is particularly important to use an RCD with portable products that are plugged into a supply which is not protected by a RCCB. If in any doubt consult a qualified electrician. You may obtain a Residual Current Device by contacting your Sealey dealer.
 - 1.1.1. You must also read and understand the following instructions concerning electrical safety.
 - 1.1.2. The **Electricity at Work Act 1989** requires that all portable electrical appliances, if used on business premises, are tested by a qualified electrician, using a Portable Appliance Tester (PAT), at least once a year.
 - 1.1.3. The **Health & Safety at Work Act 1974** makes owners of electrical appliances responsible for the safe condition of those appliances and the safety of the appliance operators.
If in any doubt about electrical safety, contact a qualified electrician.
 - 1.1.4. Ensure that the insulation on all cables and on the appliance is safe before connecting it to the power supply. See 1.1.1. and 1.1.2. and use a Portable Appliance Tester.
 - 1.1.5. Ensure that cables are always protected against short circuit and overload.
 - 1.1.6. Regularly inspect power supply leads, plugs for wear and damage and power connections, to ensure that none is loose or damaged.
 - 1.1.7. **Important:** Ensure that the voltage rating on the appliance suits the power supply to be used and that the plug is fitted with the correct fuse - see fuse rating in these instructions.
 - × **DO NOT** pull or carry the appliance by the power cable.
 - × **DO NOT** pull the plug from the socket by the cable.
 - × **DO NOT** use worn or damaged cables, plugs or connectors. Ensure that any faulty item is repaired or replaced immediately by a qualified electrician.
 - 1.1.8. This product is fitted with a BS1363/A 13 Amp 3 pin plug.
If the cable or plug is damaged during use, switch the electricity supply off and remove from use.
Ensure that repairs are carried out by a qualified electrician.
Replace a damaged plug with a BS1363/A 13 Amp 3 pin plug. If in doubt contact a qualified electrician.
 - A) Connect the GREEN/YELLOW earth wire to the earth terminal 'E'.
 - B) Connect the BROWN live wire to the live terminal 'L'.
 - C) Connect the BLUE neutral wire to the neutral terminal 'N'.Ensure that the cable outer sheath extends inside the cable restraint and that the restraint is tight.
Sealey recommend that repairs are carried out by a qualified electrician.
If an extension reel is used it should be fully unwound before connection. A reel with an RCD fitted is preferred since any appliance plugged into it will be protected. The cable core section is important and should be at least 1.5mm², but to be absolutely sure that the capacity of the reel is suitable for this product and for others which may be used in the other output sockets, we recommend the use of 2.5mm² section cable. If extension reel is to be used outdoors, ensure it is marked for outdoor use.
-
- 1.2. **GENERAL SAFETY**
 - ▲ **DANGER! BE AWARE, LEAD-ACID BATTERIES GENERATE EXPLOSIVE GASES DURING NORMAL BATTERY OPERATION. FOR THIS REASON, IT VERY IMPORTANT TO READ AND FOLLOW THESE INSTRUCTIONS CAREFULLY, EACH TIME YOU USE THE CHARGING EQUIPMENT.**
 - ✓ Follow these instructions and those published by the battery and vehicle manufacturers, and the maker of any equipment you intend to use in the vicinity of the battery. Remember to review warning marks on all products and on engines.
 - ❑ **WARNING!** Modern vehicles contain extensive electronic systems.
You are required to check with the vehicle manufacturer, for any specific instructions regarding the use of this type of equipment on each vehicle.
 - ✓ No liability will be accepted for damage / injury, where this product is not used in accordance with all instructions.

1.3. PERSONAL PRECAUTIONS

- ✓ Ensure there is another person within hearing range of your voice and close enough to come to your aid, should a problem arise when working near a lead-acid battery.
- ✓ Wear safety eye protection and protective clothing. Avoid touching eyes while working near battery.
- ✓ Have fresh water and soap nearby in case battery acid contacts skin, clothing or eyes.
- ✓ Wash immediately with soap and water if battery acid contacts skin or clothing. If acid enters eye, flush eye immediately with cool, clean running water for at least 15 minutes and seek immediate medical attention.
- ✓ Remove personal metallic items such as rings, bracelets, necklaces and watches. A lead-acid battery can produce a short-circuit current which is high enough to weld a ring or the like to metal, which would cause severe burns.
- ✓ Ensure hands, clothing (especially belts) are clear of fan blades and other moving or hot parts of engine, remove ties and contain long hair.
- ✗ **DO NOT** smoke or allow a spark or flame in the vicinity of battery or engine.

1.4. CHARGING SAFETY INSTRUCTIONS

- ✓ Familiarise yourself with the application and limitations of the charger as well as the potential hazards. Also refer to the vehicle manufacturer's hand book. **IF IN ANY DOUBT CONSULT A QUALIFIED ELECTRICIAN.**
- ✓ Ensure the charger is in good order and condition before use. If in any doubt do not use the unit, contact your Sealey stockist.
- ✓ Use the starter/charger in the upright position only and ensure it is placed on a stable surface which will adequately support its weight.
- ✓ Ensure the charger is disconnected from the mains supply before attaching/detaching the power clamps to/from the battery.
- ✓ Keep tools and other items away from the engine and ensure you can see the battery and working parts of engine clearly.
- ✓ Ensure the output of the charger is the same voltage as the battery.
- ✓ Ensure that during charging, the charger is placed in a location where there is sufficient ventilation to prevent the build up of explosive gases from a lead acid battery, and **DO NOT** cover or obstruct the charger ventilation louvres.
- ✓ If battery has caps to access the battery fluid, remove the caps and check the fluid level before connecting the power clamps.
- ✓ If necessary top-up the battery with distilled water by referring to the battery manufacturer's instructions (Apply the personal safety precautions described in part 1.3).
- ✓ If the charger receives a sharp knock or blow the unit must be checked by a qualified service agent before using.
- ✓ If the battery terminals are corroded or dirty clean them before attaching the power clamps.
- ✓ Keep children and unauthorised persons away from the working area.
- ✗ **DO NOT** dis-assemble the charger for any reason. The charger must only be checked by qualified service personnel.
- ✗ **DO NOT** try to charge a non-rechargeable battery.
- ✗ **DO NOT** try to charge battery if battery fluid is frozen.
- ☐ **WARNING!** To prevent the risk of sparking, short circuit and possible explosion **DO NOT** drop metal tools in the battery area, or allow them to touch the battery terminals.
- ✗ **DO NOT** allow power clamps to touch each other or to make contact with any metallic part of the vehicle.
- ✗ **DO NOT** cross connect power leads from charger to battery. Ensure positive (+/RED) is to positive and negative (-/BLACK) is to negative.
- ✗ **DO NOT** pull the cables or clamps from the battery terminals.
- ✗ **DO NOT** use the charger outdoors, or in damp, or wet locations and **DO NOT** operate within the vicinity of flammable liquids or gases.
- ✗ **DO NOT** use charger inside vehicle or inside engine compartment.
- ✓ Ensure there is effective ventilation to prevent a build-up of explosive gases, and **DO NOT** cover or obstruct charger ventilation louvres.
- ✗ **DO NOT** use the charger for a task for which it is not designed.
- ☐ **WARNING!** **DO NOT** simultaneously charge batteries of different capacities or discharge levels.
- ☐ **WARNING!** If a fuse blows, ensure it is replaced with an identical fuse type and rating. Use only Sealey genuine parts.
- ✓ When not in use, store the charger carefully in a safe, dry, childproof location.

This appliance can be used by children aged from 8 years and above and persons with reduced physical, sensory or mental capabilities or lack of experience and knowledge if they have been given supervision or instruction concerning use of the appliance in a safe way and understand the hazards involved. Children shall not play with the appliance. Cleaning and user maintenance shall not be made by children without supervision.

2. INTRODUCTION

Combination units capable of both charging batteries and providing boost power to help start vehicles with flat batteries. Models feature easy-to-read ammeters and illuminated power switches. Circuitry is protected by a panel-mounted fuse. Suitable for fleet operators running car and van derivatives. Built in polarity protection.

3. SPECIFICATION

MODEL No.	SUPERBOOST 140_V4	SUPERBOOST 160_V5
INPUT	230V 50 Hz	230V 50 Hz
OUTPUT VOLTAGE	12V/24V	12V/24V
CHARGE CURRENT PEAK (EN)	21A (14A)	30A (20A)
BATTERY RANGE	15-240Ah	15-300Ah
START CURRENT PEAK (EN)	140A(80A)	160A(100A)
INPUT CURRENT - CHARGE	2.7A	3.5A
INPUT CURRENT - START	11A	12.5A
POLARITY PROTECTION	1 x 50A	1 x 80A
CHARGING RATES	3	3
FUSE PART NO.	SBOOST160V519	SBOOST180V519

4. OPERATION

4.1. PREPARATION

It is important to correctly prepare for charging, ensuring that you follow Section 1 safety regulations carefully. Check that the capacity of the battery is compatible with the charger output.

4.1.1. Follow any vehicle manufacturer's instructions regarding battery charging. Note special instructions for in-vehicle charging.

4.1.2. Check the battery to ensure that the NEGATIVE and POSITIVE terminals are clearly identifiable before removing the battery from the vehicle.

- 4.1.3. Subject to 4.1.1. above, disconnect and remove the battery from the vehicle and place in an appropriate safe area ready for charging.
- 4.1.4. Remove the battery electrolyte cover or caps to allow the gases produced by charging to escape.
- 4.1.5. Check that the electrolyte is covering the plates inside. If not, add distilled water so that the plates are covered by 5-10mm.
- 4.1.6. The correct charging status of the battery may be determined by use of a hydrometer which will measure the specific gravity of the electrolyte. The following figures (kg/ltr) apply at 20°C: **1.28 = Fully charged, 1.21 = Half charged, 1.14 = Fully discharged.**

WARNING! Be cautious and vigilant as the electrolyte is a highly corrosive acid.

4.2. CONNECTING THE CHARGER TO THE BATTERY

- 4.2.1. Ensure that the battery charger is unplugged from the mains power supply before connecting the clamps to the battery.
- 4.2.1. For chargers with dual voltage output set the charger voltage to match that of the battery voltage (i.e. 12 or 24 volts) by connecting the positive (red) clamp lead to either the 12 volt output terminal or the 24 volt output terminal as appropriate.
- 4.2.2. Set the mode switch to "Charge", indicated by the battery symbol.
- 4.2.3. Set the rate of charge to that required by using the charge level switches as shown in fig. 1. The MIN & BOOST switch relates to charge levels only. When the charge level is set to BOOST the switch marked 1 & 2 is over-ridden.
- 4.2.4. Check that the charger clamps and battery terminals are clean and free from oxidation.
- 4.2.5. Connect the POSITIVE (Red or +) lead to the POSITIVE (+) terminal on the battery and the NEGATIVE (Black or -) lead to the NEGATIVE (-) terminal on the battery.

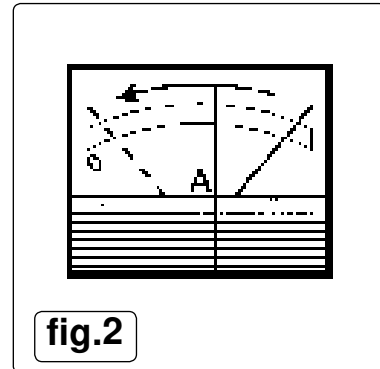
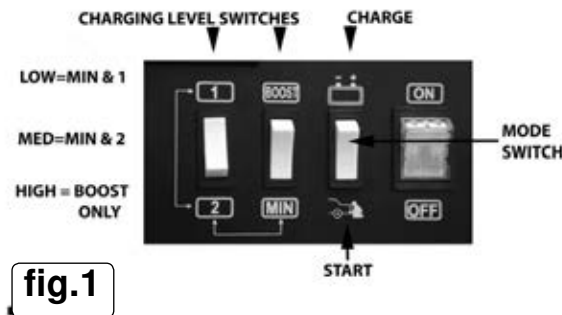

4.3. CHARGING THE BATTERY

- 4.3.1. Connect the charger to the mains power supply and switch on using front panel mounted ON / OFF switch (fig. 1).
- 4.3.2. Check the current delivery to the battery by reading the ammeter on the front of the battery charger (fig.2). During charging the pointer on the ammeter will slowly decrease (move to the left) according to the capacity and condition of the battery (see fig. 2, dial face may vary according to model of charger).
- 4.3.3. If a boost charge is required ensure that an initial charge has built up first before selecting boost on the front panel (fig.1).
- 4.3.4. When the battery is fully charged the reading on the ammeter should be at the "0" output indicator. At this point the electrolyte in the battery will begin to bubble. Stop charging at this point in order to protect the battery plates from oxidation and to keep the battery in good condition.

WARNING: The charger will not switch off automatically. The state of charge should be regularly monitored by the operator. **DO NOT** leave the charger operating unattended or overnight.

- 4.3.5. Switch the charger off and unplug from the mains power supply. Disconnect the power clamps, clean and store the charger in a safe, dry area.
- 4.3.6. Replace the battery electrolyte cover or caps. Wipe up any splashes or spillage (remember that the electrolyte is a corrosive acid). Return the battery to the vehicle and secure according to the manufacturer's instructions. Reconnect the power leads. Check to ensure all tools etc. are removed before closing the bonnet or boot.

4.4. LOW or NO MAINTENANCE BATTERIES

- 4.4.1. When charging a low, or no maintenance battery take very special care to use only a "LOW" charge setting. Use a battery tester to continually check the voltage across the clamps.
- 4.4.2. When the battery terminal voltage reaches 14.4 volts for 12V batteries or 28.8 volts for 24V batteries stop the charging process.

4.5. MULTIPLE BATTERY CHARGING

WARNING: **DO NOT** attempt to simultaneously charge different types of batteries or batteries with different capacities or levels of charge.

- 4.5.1. A number of batteries may be charged at the same time. To do so we recommend parallel connection as shown in fig.3.
- 4.5.2. Two 12 volt batteries may be charged simultaneously in series using a 24 volt output charger as shown in fig.4. This is only recommended if both batteries are of similar capacity and in a similar state of discharge.

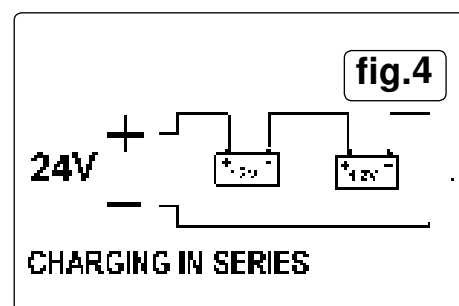
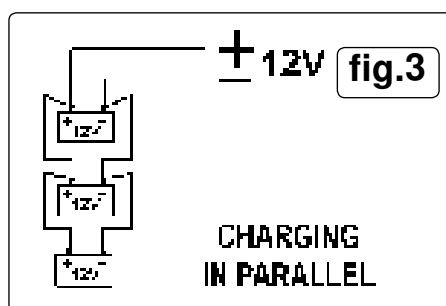

5. STARTING

- WARNING! DO NOT** attempt to start engine with starter/charger if the battery is disconnected from the vehicle. The presence of the battery is essential for the elimination of possible over-voltage that may be generated due to energy accumulating in the connection cables at the starting stage.
- 5.1. Check the vehicle manufacturers handbook and follow any special instructions. Check that the battery is in good condition.
- 5.2. Ensure the starter/charger is disconnected from the mains power supply and for models with dual voltage output set the output voltage to the same as the vehicle battery i.e. either 12V or 24V.
- 5.3. Check the charger clamps and battery terminals to ensure they are clean and free from oxidation.
- 5.4. Without removing the cables that connect the battery to the vehicle connect the charger POSITIVE (red) lead to the POSITIVE (+) terminal on the battery and the NEGATIVE (black) lead to the NEGATIVE (-) terminal on the battery.
- 5.5. Starting will be enhanced if the battery is given a short charge prior to turning the ignition switch. This must always be done with the selector switch (fig.1) set to the charge position and NOT to Boost. Plug starter/charger into mains power, select a low rate of charge and turn on. Allow the battery to charge for 2-3 minutes.
- 5.6. Move the starter/charger switch to the START position (fig.1). Turn the vehicle ignition on and crank the engine for a MAXIMUM of 3 seconds. If the vehicle does not start, wait for 2 minutes and repeat for a MAXIMUM of 5 cycles then allow 30 minutes rest.
- WARNING!** If the vehicle will not start **DO NOT** continue as the vehicle battery and electrical circuits may be damaged and the fuse in the charger will fail. Disconnect the charger and investigate the vehicle for faults.
- 5.7. When the vehicle is running switch off the starter/charger, unplug from the mains power and disconnect the power terminals from the battery.

6. SAFETY FUSE

The charger is equipped with a fuse which will protect the unit in the following circumstances:

- a) Overload: Too high a current to the battery.
- b) Short circuit: Clamps touch, or cross-connection to battery.
- c) Prolonged starting attempts.

If the fuse blows take the following action:

- 6.1. Turn the unit off and disconnect from the mains power supply.
- 6.2. Allow the unit to cool down, establish the reason for failure and correct the situation.
- 6.3. Replace the fuse (under the fuse cover on the control panel). Using only Sealey replacement parts. Refer to Specification (section 2) for details.
- WARNING! DO NOT** use a fuse with a copper bridge or similar as this will damage the equipment.



ENVIRONMENT PROTECTION

Recycle unwanted materials instead of disposing of them as waste. All tools, accessories and packaging should be sorted, taken to a recycling centre and disposed of in a manner which is compatible with the environment. When the product becomes completely unserviceable and requires disposal, drain any fluids (if applicable) into approved containers and dispose of the product and fluids according to local regulations.

Note: It is our policy to continually improve products and as such we reserve the right to alter data, specifications and component parts without prior notice.

Important: No Liability is accepted for incorrect use of this product.

Warranty: Guarantee is 12 months from purchase date, proof of which is required for any claim.

Sealey Group, Kempson Way, Suffolk Business Park, Bury St Edmunds, Suffolk. IP32 7AR



01284 757500



01284 703534



sales@sealey.co.uk



www.sealey.co.uk