



10PC FUEL PUMP TIMING KIT

MODEL NO: VSE2242.V2

Thank you for purchasing a Sealey product. Manufactured to a high standard, this product will, if used according to these instructions, and properly maintained, give you years of trouble free performance.

IMPORTANT: PLEASE READ THESE INSTRUCTIONS CAREFULLY. NOTE THE SAFE OPERATIONAL REQUIREMENTS, WARNINGS & CAUTIONS. USE THE PRODUCT CORRECTLY AND WITH CARE FOR THE PURPOSE FOR WHICH IT IS INTENDED. FAILURE TO DO SO MAY CAUSE DAMAGE AND/OR PERSONAL INJURY AND WILL INVALIDATE THE WARRANTY.



Refer to instruction manual



Wear eye protection

1. SAFETY

- WARNING!** Ensure Health and Safety, local authority and general workshop practice regulations are adhered to when using tools.
 - DO NOT** use tools if damaged.
 - Maintain tools in good and clean condition for best and safest performance.
 - Ensure that a vehicle which has been jacked up is adequately supported with axle stands.
 - Wear approved eye protection. A full range of personal safety equipment is available from your Sealey stockist.
 - Wear suitable clothing to avoid snagging. **DO NOT** wear jewellery and tie back long hair.
 - DO NOT** attempt to start engine or move vehicle whilst in gear with timing devices fitted.
 - Account for all tools, locking bolts, pins and parts being used and do not leave them in or near the engine.
- IMPORTANT:** Always refer to the vehicle manufacturer's service instructions, or a proprietary manual, to establish the current procedure and data.

2. INTRODUCTION

Suitable for timing distributor type diesel fuel pumps on engines fitted with Bosch VE Rotary, Kiki, Nippon Denso, CAV Rotodiesel - top entry port. These systems are mainly found on car and light commercial vehicles. Supplied with dial gauge in storage case.

3. SPECIFICATION

Model No:.....VSE2242.V2
Entry Port Sizes: M8, M10, M12, M14

4. CONTENTS

Item	Part Number	Description
A	VSE2242-V2-A	M14 Extension
B	VSE2242-V2-B	Adaptor Assembly M8 35mm
C	VSE2242-V2-C	Adaptor Assembly 90mm
D	VSE2242-V2-D	Adaptor Assembly M10 35mm
E	VSE2242-V2-E	M8-M12 Adaptor
F	VSE2242-V2-F	Adaptor 90mm
G	VSE2242-V2-G	Adaptor 35mm
H	VSE2242-V2-H	DTI Bracket
I	VSE2242-V2-I	Probe
J	VSE2242-V2-J	Dial Test Indicator 41mm x 8mm x 0.1mm

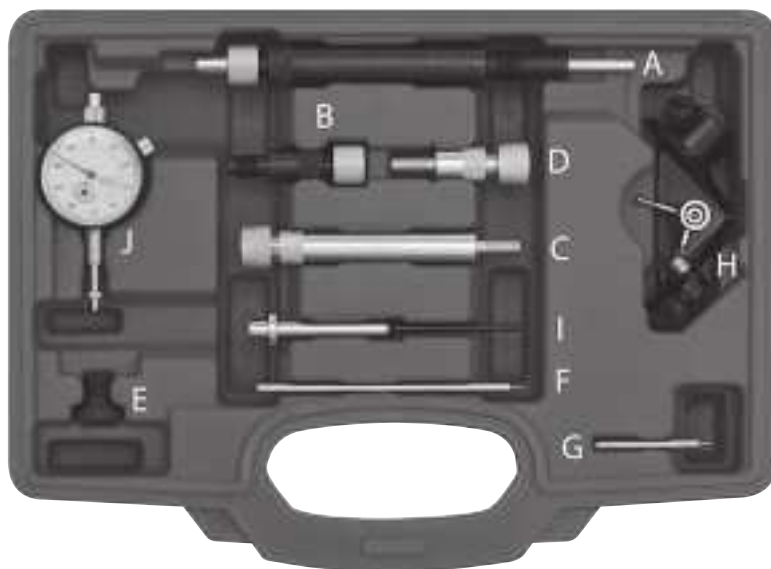

5. OPERATION

- 5.1. This kit enables you to set the correct timing position on Bosch VE type fuel pumps and compatible pumps.
- 5.1.1. Unscrew the standard tip from the dial test indicator and fix the correct extension in its place.
- 5.1.2. The short extension (G) is used with the short M8 adaptor (D), and the long extension (F) is used with the long M8 adapter (C).
- 5.1.3. Select the correct length M8 adaptor and attach the dial test indicator with extension.
- 5.1.4. Tighten the adaptor to the dial test indicator shank by using the nut and secure. Some fuel pumps have a M12 threaded port.
- 5.1.5. Item (J) can be fitted to either adaptor and converts the M8 thread to M12 (fig 1).
- 5.1.6. Clean the fuel injection pump around the service port.
- 5.1.7. Remove the plug and attach the adapter and dial test indicator. You can turn the dial test indicator to make it easy to read (fig 2)
- 5.1.8. Loosen the nut on the adapter to enable you to bring the dial test indicator and extension into contact with the pump plunger. This will pre-load the dial test indicator by approximately 1mm.
- 5.1.9. Tighten the nut to prevent the indicator sliding within the adapter.
- 5.1.10. Zero the dial test indicator bezel and lock it in position with the thumbscrew.
- 5.1.11. Turn the crankshaft backwards until the pointer on the dial test indicator stops moving. Check that the small scale on the face of the dial test indicator shows a 1mm pre-load and re-zero the bezel.
- 5.1.12. Turn the crankshaft forward to the static timing point and compare the reading on the dial test indicator with the manufacturer's specified timing data.
- 5.1.13. When the reading is correct, remove the dial test indicator, adapter and any extensions.

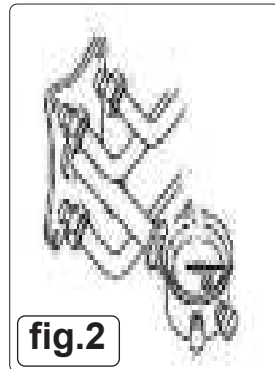
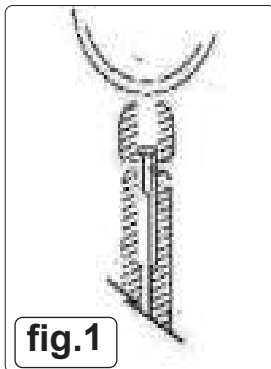

ENVIRONMENT PROTECTION

Recycle unwanted materials instead of disposing of them as waste. All tools, accessories and packaging should be sorted, taken to a recycling centre and disposed of in a manner which is compatible with the environment. When the product becomes completely unserviceable and requires disposal, drain any fluids (if applicable) into approved containers and dispose of the product and fluids according to local regulations.



Note: It is our policy to continually improve products and as such we reserve the right to alter data, specifications and component parts without prior notice. Please note that other versions of this product are available. If you require documentation for alternative versions, please email or call our technical team on technical@sealey.co.uk or 01284 757505.

Important: No Liability is accepted for incorrect use of this product.

Warranty: Guarantee is 12 months from purchase date, proof of which is required for any claim.

Sealey Group, Kempson Way, Suffolk Business Park, Bury St Edmunds, Suffolk. IP32 7AR



01284 757500



01284 703534



sales@sealey.co.uk



www.sealey.co.uk