



# 20L WET & DRY VALETING MACHINE WITH ACCESSORIES 1400W

MODEL NO: **PC310.V2**

Thank you for purchasing a Sealey product. Manufactured to a high standard, this product will, if used according to these instructions, and properly maintained, give you years of trouble free performance.



**IMPORTANT:** PLEASE READ THESE INSTRUCTIONS CAREFULLY. NOTE THE SAFE OPERATIONAL REQUIREMENTS, WARNINGS & CAUTIONS. USE THE PRODUCT CORRECTLY AND WITH CARE FOR THE PURPOSE FOR WHICH IT IS INTENDED. FAILURE TO DO SO MAY CAUSE DAMAGE AND/OR PERSONAL INJURY AND WILL INVALIDATE THE WARRANTY. KEEP THESE INSTRUCTIONS SAFE FOR FUTURE USE.

## 1. SAFETY

### 1.1. ELECTRICAL SAFETY

- WARNING!** It is the user's responsibility to check the following:
  - ✓ Check all electrical equipment and appliances to ensure that they are safe before using. Inspect power supply leads, plugs and all electrical connections for wear and damage. Sealey recommend that an RCD (Residual Current Device) is used with all electrical products.
- Electrical safety information.** It is important that the following information is read and understood:
  - ✓ Ensure that the insulation on all cables and on the appliance is safe before connecting it to the power supply.
  - ✓ Regularly inspect power supply cables and plugs for wear or damage and check all connections to ensure that they are secure.
- Important:** Ensure that the voltage rating on the appliance suits the power supply to be used and that the plug is fitted with the correct fuse.
- ✗ **DO NOT** pull or carry the appliance by the power cable.
- ✗ **DO NOT** pull the plug from the socket by the cable.
- ✗ **DO NOT** use worn or damaged cables, plugs or connectors. Ensure that any faulty item is repaired or is replaced immediately by a qualified electrician. If the cable or plug is damaged during use, switch off the electricity supply and remove from use.

**Ensure that repairs are carried out by a qualified electrician.**

### 1.2. GENERAL SAFETY

- ✓ Children from age 8 years and above, persons with reduced physical, sensory, or mental capabilities those with lack of experience and knowledge can use the appliance, if they have been given supervision or instruction concerning use of the appliance in a safe way to understand the hazards involved.
- ✓ Children shall **NOT** play with the appliance
- ✓ Cleaning and user maintenance on the appliance shall not be made by children without supervision.
- ✓ The plug must be removed from the socket-outlet before cleaning or maintaining the appliance.
- ✓ Disconnect the appliance from its power source during service and when replacing parts and, if that the removal of the plug is foreseen, it shall be clearly indicated that the removal of the plug has to be such that an operator can check from any of the points to which he has access that the plug remains removed.
- ✓ Before operation, please check if the local power supply is the same as it's rated in the specification.
- ✓ If the supply cord is damaged, it must be replaced by the manufacturer, its service agent or similarly qualified persons in order to avoid a hazard.
- ✓ Remember to turn off the appliance and remove the plug every time after use or when being repaired.
- ✓ Keep machine away from strong sunlight and high temperatures in case plastic is damaged.
- ✗ **DO NOT** use this machine as a pump.
- ✗ **DO NOT** pull the appliance by the hose.
- ✗ **DO NOT** stand on the hose or appliance.
- ✗ **DO NOT** immerse the head unit in water or wash with water in case that water goes into the electronic parts and causes personal injury.
- ✗ **DO NOT** use this appliance in any combustible and explosive places in case the motor sparks and causes a fire.
- ✗ **DO NOT** jam the air inlet as this may cause temperature rises and damage to the motor.
- ✗ **DO NOT** use the appliance to collect combustible and explosive materials such as petrol, oils etc.
- ✗ **DO NOT** use the appliance to collect sharp objects like pins and screws as this may damage internal components.
- ✗ **DO NOT** use for ash, hot embers etc.
- ✗ **DO NOT** use the appliance to collect powders that can easily block the ventilation holes and damage the motor.
- ✗ **DO NOT** overturn the machine in case water goes into the motor and damages the motor.
- ✗ **DO NOT** use a cleaning agent or detergent containing solvent.
- ✗ **DO NOT** collect combustible and explosive objects such as glowing cigarettes, gasoline, etc.
- ✗ **DO NOT** collect objects which can easily attach on the filter such as calcareousness powder, gesso and graphite powder because those will block the ventilation damage motor.

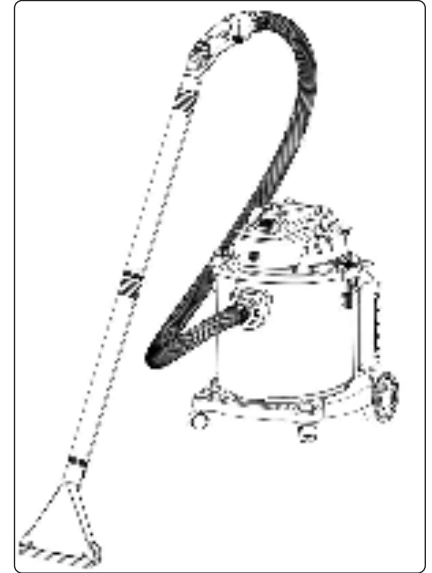

## 2. INTRODUCTION

Cleans carpets, car interiors, fabrics and upholstery. Constructed from high-impact plastic which is dent resistant and rustproof. Supplied with carpet lance, handheld lance, full wet and dry vacuum accessory kit, including aluminium rigid extension tube, cartridge filter and foam filter. Powerful pump forces cleaning fluid into fabric/carpet and 1400W suction power leaves surface virtually dry after one pass. Features safety shut-off for wet operation. Large capacity drum with external detergent tank for easy filling. Fitted with two fixed wheels and two castors. Cable storage hook, accessories and extension tube holders on head, plus additional accessory storage slots on base.

### 3. SPECIFICATION

<b>MODEL NO:</b>	<b>PC310 .V2</b>
Drum Size:	20L
Drum Type:	Plastic
Filter Type:	PET Type Cartridge
Fuse Rating:	3A
Motor Power:	1400W
Optional Accessories:	PC200PB5 - Optional Dust Bags (Pack of 5)
Power Supply Cable Length:	4.5m
Replacement Parts:	PC310CF - Cartridge Filter
Supply:	230V

**RECOMMENDED DETERGENT:**  
**Carpet/Upholstery Detergent 2.5L**  
 • (Single) VMR9225  
**Carpet/Upholstery Detergent 5L**  
 • (Pack of 4) VMR925  
 • (Single) VMR925S  
**Carpet/Upholstery Detergent 25L**  
 • (Single) VMR92250

Weight	7.24kg
--------	--------

### 4. CONTENTS

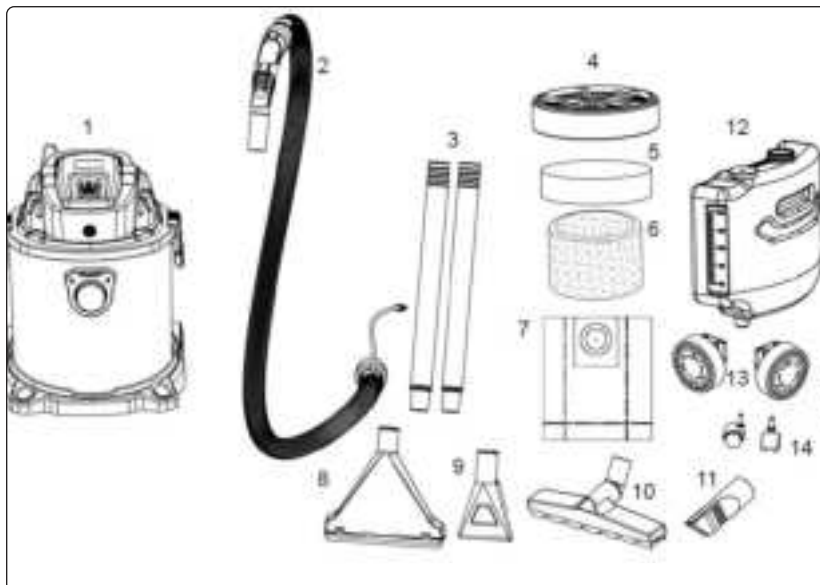

1	Tank unit (head, Tank, base)
2	Flexible hose + detergent spray gun
3	2pcs connection tubes
4	HEPA filter (optional)
5	Sponge filter (optional)
6	Sponge filter
7	Dust bag (for dry use)
8	Washing brush (for carpet)
9	Washing brush (for sofa)
10	Wet & dry floor brush
11	2 in 1 crevice nozzle
12	Detergent tank
13	2pcs rear wheels
14	2pcs front wheels
15	4pcs screws (for rear wheels)

### 5. ASSEMBLY

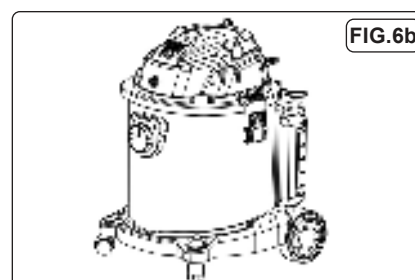
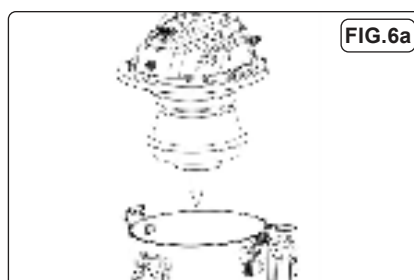
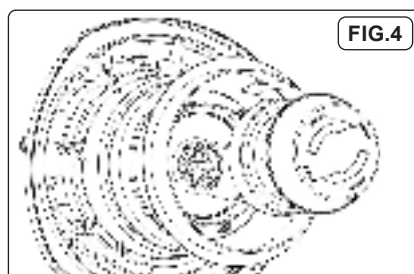
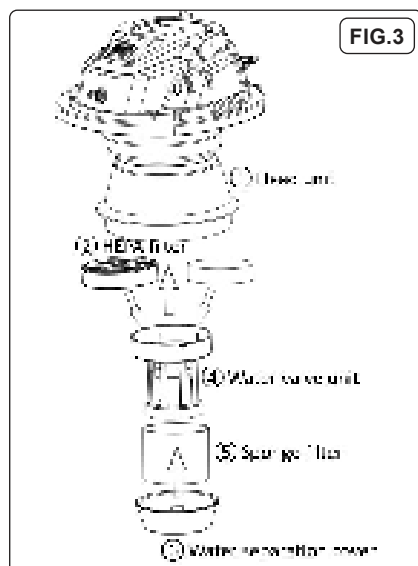
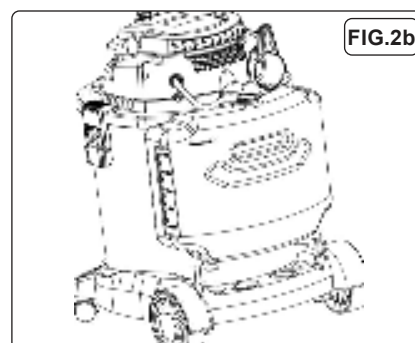
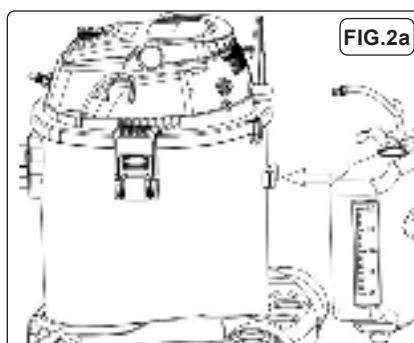
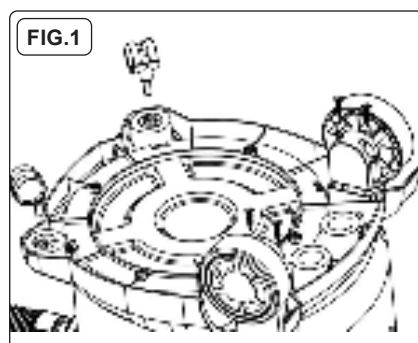

**5.1. BASE & WHEELS (FIG.1)**

Press the 2pcs front wheels into the base position, and screw the 2pcs rear wheels.

**5.2. DETERGENT TANK (FIG.2)**

Fit the detergent tank on the base, with the humps into the slots. Press the detergent tank onto the stainless steel one, and buckle it.

**5.3. FILTERS (FIG.3, 4, 5 & 6)**

Fit the HEPA filter according to fig.3. Insert the water valve unit into the head unit, and turn it clockwise to lock (fig.4). Before cleaning dry dust, lock the dust bag onto the suction port on the tank (fig.5). Secure the head unit onto the tank (fig.6).

**5.4. HOSE, TUBE, BRUSH & DETERGENT PIPE (FIG.7A & 7B)**

Check the tightness of the following parts, in case of suction and water leakage.

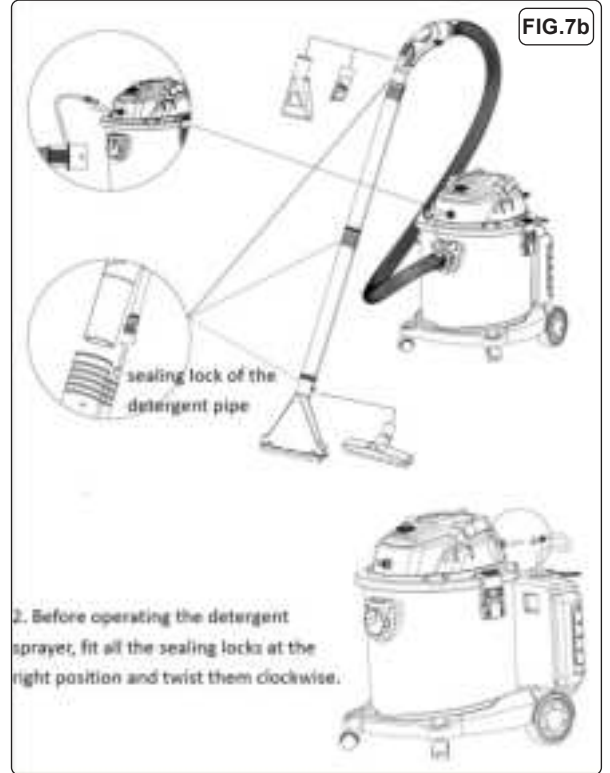

**5.5. DETERGENT (FIG.8)**

Fill the detergent tank with detergent; the max volume is 3L. Thick detergent should be diluted or the pipe may block.

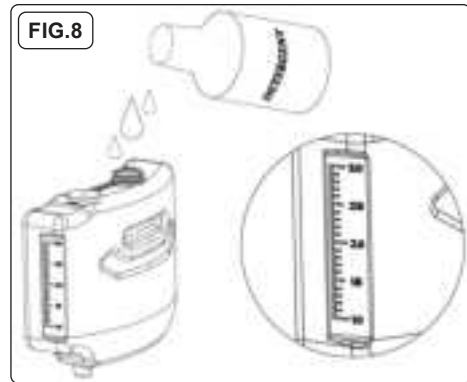

**6. OPERATION**

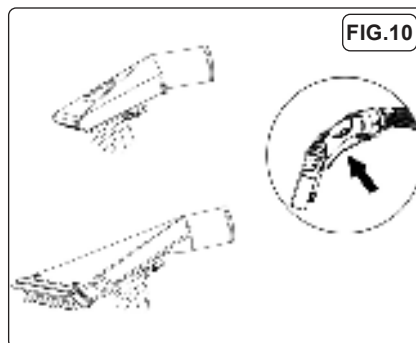
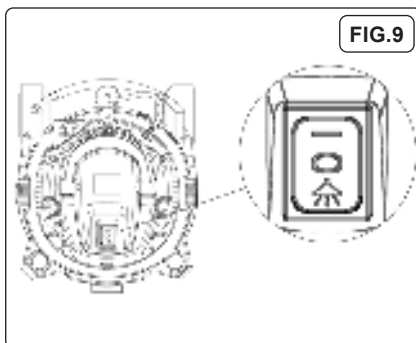

**6.1. SWITCH (FIG.9)**

The switch has three options:

(I) - Turns the unit ON.

(O) - Turns the unit OFF.



- Operates the detergent pump and spray gun.

## WET OPERATION

### 6.2. CARPET & SOFA WASHING (FIG.10)

Choose the corresponding brush for cleaning. Ensure there is enough detergent in the tank for best performance. Remove the dust bag. Ensure large particles of dust are removed before washing. Press the button of the detergent spray gun to spray detergent.

**NOTE:** on the first use, hold for 10 seconds to allow the detergent time to pump out. Move the brush evenly and slowly across the carpet or sofa. Release the button on the backstroke to allow for vacuuming of waste water.

### 6.3. FLOOR CLEANING (FIG.11)

Use the wet & dry floor brush for cleaning floor, dust, rubbish, spillage, etc.

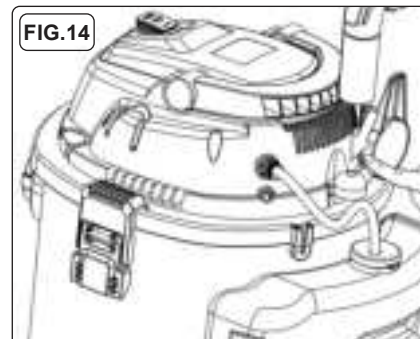
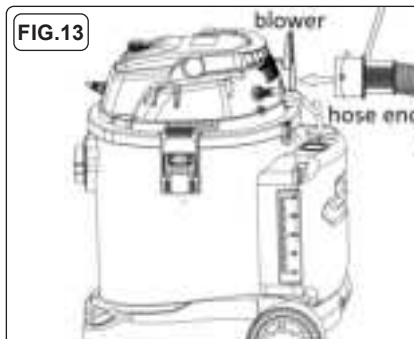
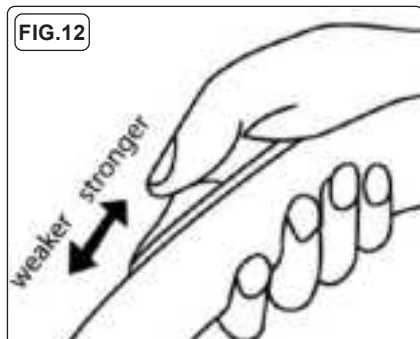

### 6.4. AIRFLOW ADJUSTMENT (FIG.12)

Press the button on the detergent spray gun to adjust the suction.

### 6.5. BLOWING FUNCTION (FIG.13)

Insert the end of the plastic hose into the blower, and twist it clockwise to lock. Switch on the vacuum cleaner to start the blower.

### 6.6. FILTER-CLEANING FUNCTION (FIG.14)

If using to clean thick dust, such as that in a garden, workshop or newly decorated room, the filters will get clogged easily. In this case, press the filter-cleaning button on the back of the unit several times. Suction power should improve afterwards.

### 6.7. PROTECTIVE DEVICE - WATER VALVE (FIG.15)

The protective valve begins to work when the tank is full of dirty water. The appliance will make a noise that indicates the motor is running at a higher speed. When this occurs, turn off the appliance and empty the water.

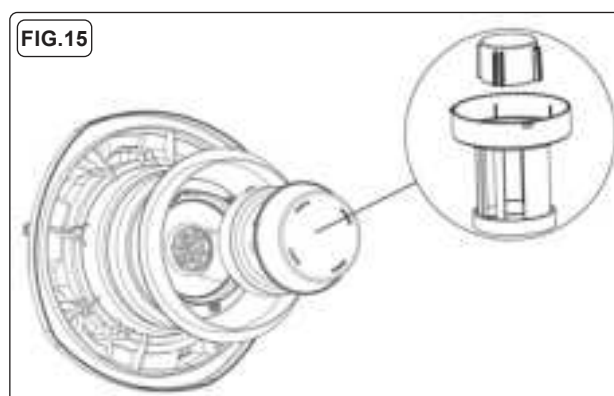

## 7. MAINTENANCE

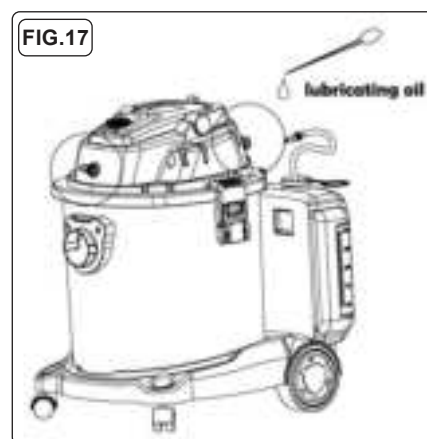
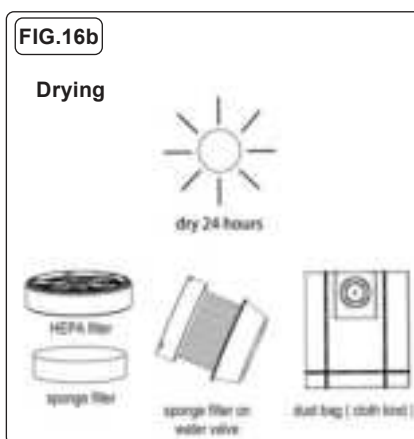

### 7.1. CLEANING (FIG.16A & 16B)

After heavy use, or when the barrel is full of dust and dirty water, please follow the procedure below:

- 7.1.1. Unfasten the clips and remove the head unit.
- 7.1.2. Take off the filter bag, pour out and clean up the dust and dirty water in tank, and wipe the tank dry.
- 7.1.3. Wash and clean the filters, including HEPA filter and sponge filters. Filters should be dried before the next use.  
**NOTE:** Filters should be changed regularly to ensure optimal performance.
- 7.1.4. Reinstall all the accessories and units as per the assembly instructions above.

### 7.2. LUBRICATING OIL (FIG.17)

Moderate lubricating oil should be added to the sealing locks and pipe jacks for smooth operation.

## 8. TROUBLESHOOTING

SYMPTOM	POSSIBLE CAUSE	SOLUTION
Dust/ liquid / detergent leaks from the hose / tubes / pipes	<ol style="list-style-type: none"> <li>Accessories are not installed correctly.</li> <li>The rubber seal ring of detergent pipe has broken or fallen off.</li> </ol>	<ol style="list-style-type: none"> <li>Follow the assembly instructions and check the tightness of accessory joints.</li> <li>Contact your stockist for repair/ replacement, or re-tighten the seal ring.</li> </ol>
Weak suction	<ol style="list-style-type: none"> <li>The filters, tubes, hose or suction port is blocked.</li> <li>The head unit is not connected correctly.</li> </ol>	<ol style="list-style-type: none"> <li>Clean up the filters and the accessories, or make use of the filter-cleaning function.</li> <li>Reset the head unit and buckle it on the tank as per the assembly instructions.</li> </ol>
Abnormal noise when operating	<ol style="list-style-type: none"> <li>Dirty water tank is full.</li> <li>The vacuum has been turned over.</li> </ol>	<ol style="list-style-type: none"> <li>Empty the dirty water from the tank.</li> <li>Ensure the vacuum is upright when operating.</li> </ol>
Unit begins to smoke	Overheated, overloaded or damaged motor.	Switch off and unplug from power supply. <b>DO NOT</b> continue to use. Contact your stockist for repair/replacement.
Dirty water or foam is blowing out from the blower or the head.	<ol style="list-style-type: none"> <li>Filters are not installed correctly.</li> <li>Filters should be replaced.</li> <li>Too much foam in the tank.</li> </ol>	<ol style="list-style-type: none"> <li>Check the installation of filters.</li> <li>Replace the filters with new ones.</li> <li>Use low-foaming detergent. Clean up the dirty water and foam in the tank.</li> </ol>



### ENVIRONMENT PROTECTION

Recycle unwanted materials instead of disposing of them as waste. All tools, accessories and packaging should be sorted, taken to a recycling centre and disposed of in a manner which is compatible with the environment. When the product becomes completely unserviceable and requires disposal, drain any fluids (if applicable) into approved containers and dispose of the product and fluids according to local regulations.



REGISTER YOUR PURCHASE HERE



### WEEE REGULATIONS

Dispose of this product at the end of its working life in compliance with the EU Directive on Waste Electrical and Electronic Equipment (WEEE). When the product is no longer required, it must be disposed of in an environmentally protective way. Contact your local solid waste authority for recycling information.

**Note:** It is our policy to continually improve products and as such we reserve the right to alter data, specifications and component parts without prior notice. Please note that other versions of this product are available. If you require documentation for alternative versions, please email or call our technical team on [technical@sealey.co.uk](mailto:technical@sealey.co.uk) or 01284 757505.

**Important:** No Liability is accepted for incorrect use of this product.

**Warranty:** Guarantee is 12 months from purchase date, proof of which is required for any claim.

Sealey Group, Kempson Way, Suffolk Business Park, Bury St Edmunds, Suffolk. IP32 7AR



01284 757500



[sales@sealey.co.uk](mailto:sales@sealey.co.uk)



[www.sealey.co.uk](http://www.sealey.co.uk)