

105 Motorcycle Bluetooth® Communication System

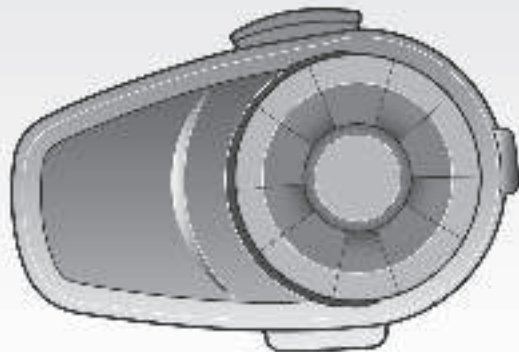

© 1998-2016 Sena Technologies, Inc. All rights reserved.

Sena Technologies, Inc reserves the right to make any changes and improvements to its product without providing prior notice.

Sena™ is a trademark of Sena Technologies, Inc. or its subsidiaries in the USA and other countries. Prism™, Bluetooth Audio Pack for GoPro®, Tufftalk™, 20S™, 10S™, 10C™, 10U™, 10R™, 3S™, SMH10™, SMH10R™, SMH5™, SMH5-FM™, SMH3™, SPH10™, SPH10H™, SPH10H-FM™, SPH10S™, Expand™, Bluetooth Mic&Intercom™, Handlebar Remote™, Wristband Remote™, SM10™, SR10™, SR10i™ are trademarks of Sena Technologies, Inc. or its subsidiaries. These trademarks may not be used without the express permission of Sena.

GoPro® is a registered trademark of Woodman Labs of San Mateo, California. Sena Technologies, Inc. (“Sena”) is not affiliated with Woodman Labs. The Sena Bluetooth Pack for GoPro® is an after-market accessory specially designed and manufactured by Sena Technologies, Inc. for the GoPro® Hero3 and Hero4 allowing for Bluetooth capabilities.

The Bluetooth® word mark and logos are owned by the Bluetooth SIG, Inc. and any use of such marks by Sena is under license. iPhone, iPod touch are registered trademarks of Apple Inc. Zumo™ is a trademark of Garmin Ltd. or its subsidiaries. TomTom™ is the trademark or registered trademark owned by TomTom International B.V. Other trademarks and tradenames are those of their respective owners.

CONTENTS

1	INTRODUCTION	5
2	PACKAGE CONTENTS	6
3	INSTALLING THE 10S ON YOUR HELMET	8
3.1	Installing the Main Unit.....	9
3.2	Installing the Speakers.....	11
3.3	Installing the Microphones.....	12
4	GETTING STARTED	14
4.1	Button Operation.....	14
4.2	Powering On and Off.....	15
4.3	Charging.....	15
4.4	Low Battery Warning.....	15
4.5	Checking the Battery Level.....	15
4.6	Volume Adjustment.....	16
4.7	Sena Softwares.....	16
5	PAIRING THE 10S WITH BLUETOOTH DEVICES	17
5.1	Mobile Phone Pairing - Mobile Phone, Bluetooth Stereo Device.....	17
5.2	Second Mobile Phone Pairing - Second Mobile Phone, GPS, and SR10.....	18
5.3	Advanced Selective Pairing - A2DP Stereo or Handsfree.....	19
5.4	Intercom Pairing.....	20
6	MOBILE PHONE, GPS, SR10	22
6.1	Mobile Phone Call Making and Answering.....	22
6.2	Speed Dialing.....	22
6.3	GPS Navigation.....	23
6.4	Sena SR10, Two-Way Radio Adapter.....	23
7	STEREO MUSIC	24
7.1	By Bluetooth Wireless Stereo.....	24
7.2	By Stereo Audio Cable.....	25
7.3	Music Sharing.....	25
8	INTERCOM	26
8.1	Two-way Intercom.....	26
8.2	Three-way Intercom.....	27
8.3	Four-way Intercom.....	29
9	THREE-WAY CONFERENCE PHONE CALL WITH INTERCOM PARTICIPANT	30
10	GROUP INTERCOM	31
11	UNIVERSAL INTERCOM	31
11.1	Universal Intercom Pairing.....	32
11.2	Two-way Universal Intercom.....	33
11.3	Three-way Universal Intercom.....	33
11.4	Four-way Universal Intercom.....	34
12	FM RADIO	36
12.1	FM Radio On and Off.....	36
12.2	Preset Stations.....	36
12.3	Seek and Save.....	37
12.4	Scan and Save.....	37
12.5	Temporary Preset.....	38
12.6	Region Selection.....	38

13	FUNCTION PRIORITY	38
14	CONFIGURATION SETTING	39
14.1	Assigning Speed Dial	40
14.2	Enabling/Disabling Audio Boost	40
14.3	Enabling/Disabling Voice Activated Phone Answering	41
14.4	Enabling/Disabling Voice Activated Intercom	41
14.5	Enabling/Disabling HD Intercom	42
14.6	Enabling/Disabling Voice Prompts	42
14.7	Enabling/Disabling RDS AF	43
14.8	Enabling/Disabling Sidetone	43
14.9	Enabling/Disabling Advanced Noise Control™	43
14.10	Delete All Bluetooth Pairing Information	44
14.11	Remote Control Pairing	44
14.12	Universal Intercom Pairing	44
14.13	Exit Voice Configuration Menu	44
15	REMOTE CONTROL	45
15.1	Pairing with the Handlebar Remote	45
15.2	Using the Handlebar Remote	46
16	FIRMWARE UPGRADE	47
17	TROUBLESHOOTING	47
17.1	Intercom Failure	47
17.2	Intercom Reconnection	47
17.3	Fault Reset	48
17.4	Factory Reset	48
18	OPERATION QUICK REFERENCE	49

CERTIFICATION AND SAFETY APPROVALS	50
• FCC Compliance Statement	50
• FCC RF Exposure Statement	51
• FCC Caution	51
• CE Declaration of Conformity	51
• Industry Canada Statement	51
• Bluetooth License	52
• WEEE (Waste Electrical and Electronic Equipment)	52
SAFETY INFORMATION	52
• Product Storage and Management	52
• Product Use	53
• Battery	53
PRODUCT WARRANTY AND DISCLAIMER	54
• Limited Warranty	54
• Warranty Exclusions	56
• Warranty Service	58

1 INTRODUCTION

Thank you for choosing the Sena 10S, Motorcycle Bluetooth Communication System. With the 10S, you can call handsfree on your Bluetooth mobile phone, listen to stereo music or voice instructions of GPS navigations wirelessly, and have intercom conversations in full duplex with a passenger or other motorcycle riders.

The 10S is compliant with the Bluetooth 4.1 supporting the following profiles: Headset Profile, Hands-Free Profile (HFP), Advanced Audio Distribution Profile (A2DP), and Audio Video Remote Control Profile (AVRCP). Please check with the manufacturers of other device to determine their compatibility with this headset.

Please read this User's Guide carefully before using the headset. Also check www.sena.com for the latest version of the User's Guide and additional information related to Sena Bluetooth products.

The 10S features:

- Bluetooth 4.1
- Multi-way intercom up to 4 connections
- Bluetooth intercom up to 1.6 kilometers (1.0 miles)*
- Smartphone App for iPhone and Android
- Universal Intercom™
- Music Sharing
- Intuitive voice prompts
- Advanced Noise Control™
- Easy operation by versatile Jog Dial
- Can be used while charging on road trips
- Water resistant for use in inclement weather
- Built-in FM radio tuner with a station scan and save function
- Optional Handlebar Remote support (not included)
- Firmware upgradeable

.....
* in open terrain

Key Specifications:

- Bluetooth 4.1
- Supporting profiles: Headset Profile, Hands-Free Profile (HFP), Advanced Audio Distribution Profile (A2DP), and Audio Video Remote Control Profile (AVRCP).

2 PACKAGE CONTENTS

- **Headset Main Unit**



- **Clamp Unit**

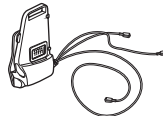

- **Glued Surface Mounting Adapter**



Speaker

- **Speakers (2)**



- **Hook and Loop Fasteners for Speakers (4)**



- **Speaker Pads (Thick) (2)**



- **Speaker Pads (Thin) (2)**



Wired Microphone

- **Wired Microphone**



- **Hook and Loop Fastener for Wired Microphone**



Wired Boom Microphone

- **Wired Boom Microphone**



- **Hook and Loop Fastener for Wired Microphone**



- **Microphone Sponges (2)**



- **Boom Microphone Holder**



- **Hook and Loop Fastener for Boom Microphone Holder**



Others

- **USB Power & Data Cable**



- **Allen Wrench**



- **Cigarette Charger**



- **2.5 to 3.5mm Male to Male Stereo Audio Cable**

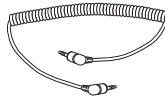

3 INSTALLING THE 10S ON YOUR HELMET

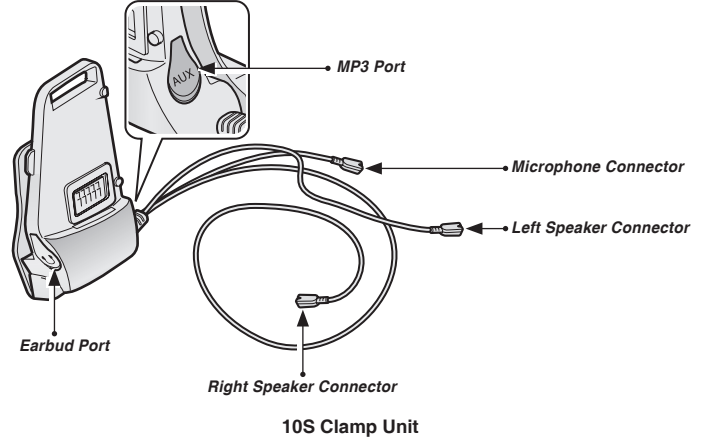

3.1 Installing the Main Unit

3.1.1 Using the Clamp Unit

1. Loosen the two screws on the back plate of the clamp unit with the included allen wrench.

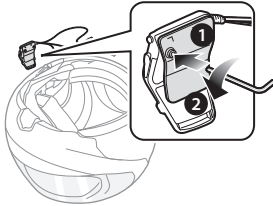

2. Insert the back plate of the clamp unit between the internal padding and external shell of the left side of the helmet.

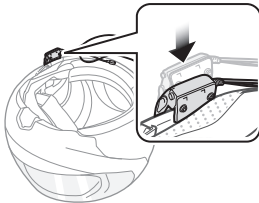

3. Tighten the two screws until the clamp unit is fastened firmly to the helmet.

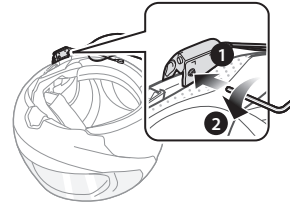

4. Attach the main unit to the clamp unit until you hear a click. The main unit is now fastened to the clamp unit.

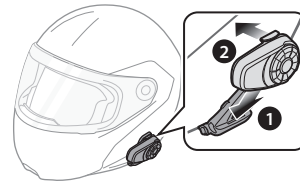

3.1.2 Using the Glued Surface Mounting Adapter

If you cannot install the clamp unit on the helmet, you can use the glued surface mounting adapter to attach the clamp unit to the surface of the helmet.

1. Clean the area on the left side of the helmet where you will attach the glued surface mounting adapter with a moistened towel and dry thoroughly.
2. Peel off the cover of adhesive tape of the glued surface mounting adapter and attach it to the helmet.

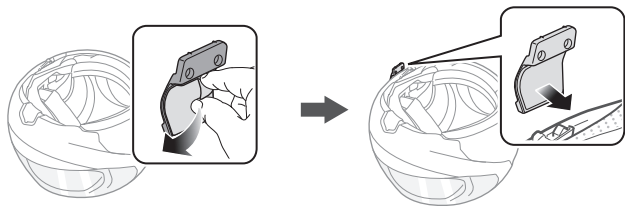

3. Make sure that the glued surface mounting plate sticks on the helmet firmly. Maximum adhesion occurs after 24 hours.
4. Attach the clamp unit on the glued surface mounting adapter using two screws.

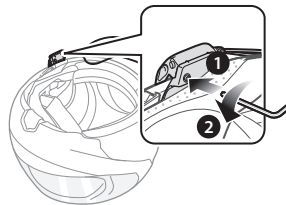

CAUTION:

Sena recommends using the clamp unit. The glued surface mounting adapter is provided for convenience, but is not the recommended mounting method. Sena is not responsible for its use.

5. Attach the main unit to the glued surface mounting adapter until you hear a click. The main unit is now fastened to the clamp unit.

3.2 Installing the Speakers

1. Peel off each cover of the hook and loop fasteners for speakers to expose the adhesive surface. Then, attach the fasteners to the ear pockets inside the helmet.

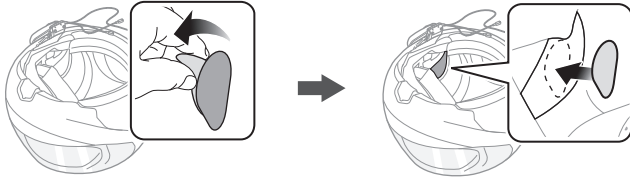

2. Attach the speakers to the hook and loop fasteners for speakers inside the helmet.

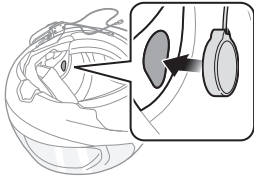

3. Align the arrows on the clamp unit and speaker cables and insert speaker cables into each speaker connector.

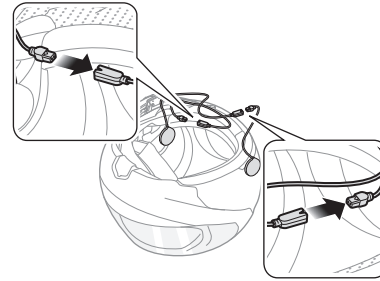

Note:

1. Three cables connect to the clamp unit. The longest is the cable for the right speaker. The second longest cable is for the left speaker. The shortest cable is for the microphone.
2. If the helmet has deep ear pockets, you can use the speaker pads to bring the speakers closer to your ears.

3.3 Installing the Microphones

3.3.1 Using the Wired Boom Microphone

1. Peel off the cover of the hook and loop fastener for wired boom microphone to expose the adhesive tape. Then, attach the hook and loop fastener on the inside surface of the left external shell.

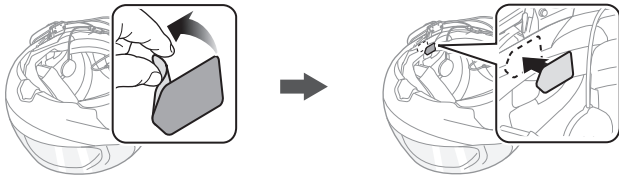

2. Attach the wired boom microphone's mounting plate to the hook and loop fastener.

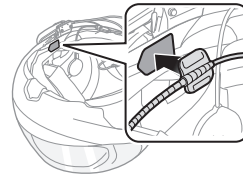

Note:

1. After you install the wired boom microphone, make sure you reinstall the helmet's internal padding.
2. You can use the boom microphone holder after attaching the hook and loop fastener for boom microphone holder on it to ensure secure installation.

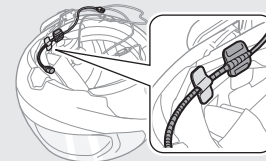

3. Make sure that the microphone's receiver is located near your mouth.

- Adjust the head of the microphone so that the tab is facing away from your mouth.

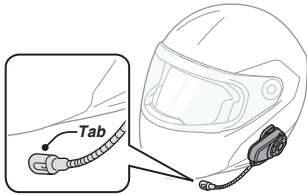

- Align the arrows on the clamp unit and microphone cables and insert the microphone cable into the microphone connector.

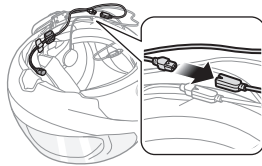
**Note:**

Three cables connect to the main unit. The longest is the cable for the right speaker. The second longest cable is for the left speaker. The shortest cable is for the microphone.

3.3.2 Using the Wired Microphone

If you have a full face helmet, you can use the wired microphone.

- Peel off the cover of the hook and loop fastener for wired microphone to expose the adhesive tape. Then, attach the hook and loop fastener on the inside of the helmet's chin guard.

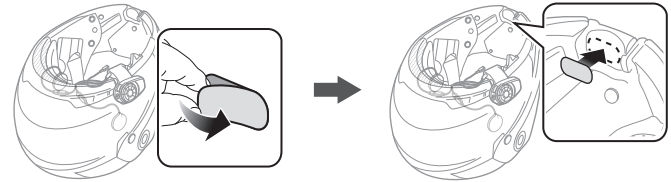

- Attach the wired microphone to the hook and loop fastener for wired microphone.

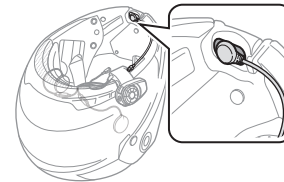

- Align the arrows on the clamp unit and microphone cables and insert the microphone cable into the microphone connector.

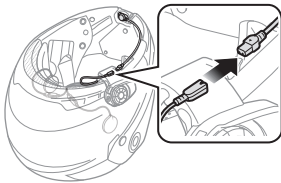
**Note:**

- After connecting all cables, store any excess cables behind the internal padding of helmet to prevent wires from becoming damaged.
- Three cables connect to the main unit. The longest is the cable for the right speaker. The second longest cable is for the left speaker. The shortest cable is for the microphone.

CAUTION:

When you remove the headset, make sure that you first detach all cables from the clamp unit. Then it is safe to remove the main unit and clamp unit in order.

4 GETTING STARTED

4.1 Button Operation

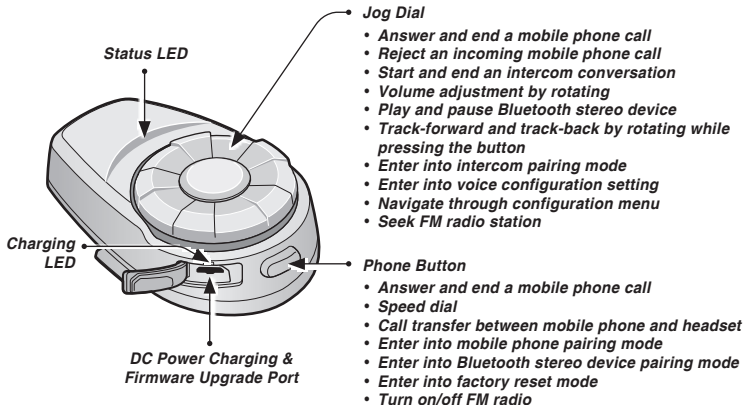

10S Headset Buttons

4.2 Powering On and Off

To power on the headset, press the Phone Button and the Jog Dial at the same time while hearing ascending beeps and a voice prompt, “Hello”. To power off the headset, press the Phone Button and the Jog Dial at the same time while hearing descending beeps and a voice prompt, “Goodbye”.

4.3 Charging

You can charge the headset by connecting the supplied USB power & data cable into a computer’s USB port or USB wall charger. You can use any standard micro USB cable to charge the units. You can also charge them on the road using the cigarette charger. The charging LED turns red while charging and turns blue when fully charged. It takes about 2.5 hours to be completely charged.

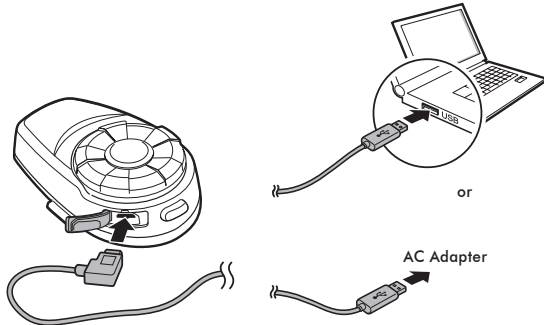

4.4 Low Battery Warning

When the battery is low, the blinking blue LED in stand-by mode turns to red and you will hear mid-tone triple beeps and a voice prompt, “Low battery”.

4.5 Checking the Battery Level

You can check the battery level in two different ways when the headset is powering on.

4.5.1 LED Indicator

When the headset is powering on, the red LED flashes rapidly indicating the battery level.

4 flashes = High, 70 ~ 100%

3 flashes = Medium, 30 ~ 70%

2 flashes = Low, 0 ~ 30%

4.5.2 Voice Prompt Indicator

When you power on the headset, keep pressing the Phone Button and the Jog Dial simultaneously for about 3 seconds until you hear three, high toned beeps. Then you will hear a voice prompt indicating the battery level. However, if you release the buttons as soon as the headset turns on, you will not hear a voice prompt for the battery level indication.

4.6 Volume Adjustment

You can easily adjust the volume by rotating the Jog Dial. You will hear a beep when the volume reaches the maximum or minimum level. The volume is set and maintained independently at different levels for each audio source even when you reboot the headset. For example, once you set the volume for mobile phone handsfree, it will not change even if you adjust the volume for your Bluetooth MP3 music. However, if you adjust the volume during stand-by mode, it will affect volume levels of every audio source.

4.7 Sena Softwares

4.7.1 Sena Device Manager

The Sena Device Manager allows you to upgrade the firmware and configure the device settings directly from your PC. Using this software, you can assign speed dial presets, FM radio frequency presets and more. It is available for both Windows and Mac. For more information on downloading the Device Manager, please visit www.sena.com.

4.7.2 Sena Smartphone App

The Sena Smartphone App allows you to configure device settings and read the User's Guide and the Quick Start Guide. Pair your phone with your 10S headset (please refer to *section 5.1, "Mobile Phone Pairing - Mobile Phone, Bluetooth Stereo Device"*). Run the Sena Smartphone App and you can configure its settings directly from your smartphone. You can download the Sena Smartphone App for Android or iPhone from www.sena.com/headset-app/.

5 PAIRING THE 10S WITH BLUETOOTH DEVICES

Before using the 10S Bluetooth headset with any other Bluetooth devices for the first time, you will need to pair them together. You can pair the 10S with Bluetooth mobile phones, Bluetooth stereo devices such as MP3 players, or motorcycle specific Bluetooth GPS navigation, and with other Sena Bluetooth headsets. The pairing operation is required only once for each Bluetooth device. The headset remains paired with the devices and automatically reconnects to them when they are within range. You will hear a high toned single beep and a voice prompt whenever the headset reconnects to the paired device: **“Phone connected”** to a mobile phone, **“Media connected”** to a Bluetooth stereo device.

5.1 Mobile Phone Pairing - Mobile Phone, Bluetooth Stereo Device

1. Press and hold the Phone Button for 5 seconds until you hear a voice prompt, **“Phone pairing”**.
2. Search for Bluetooth devices on your mobile phone. Select the Sena 10S in the list of the devices detected on the mobile phone.
3. Enter 0000 for the PIN. Some mobile phones may not ask for the PIN.
4. The mobile phone confirms that pairing has been completed and the 10S is ready to use. You will hear a voice prompt, **“Your headset is paired”**.
5. If the pairing process is not completed within three minutes, the 10S will return to stand-by mode.

Note:

1. If the Bluetooth connection between the headset and a mobile phone is disconnected, tap the Phone Button to recover the Bluetooth connection immediately.
2. If the Bluetooth connection between the headset and a media player is disconnected, press the Jog Dial for 1 second to recover the Bluetooth connection and play.

5.2 Second Mobile Phone Pairing - Second Mobile Phone, GPS, and SR10

Typical Bluetooth headsets can connect with only one Bluetooth device, but a second mobile phone pairing allows the headset to connect with another Bluetooth device such as a second mobile phone, an MP3 Player, or the Sena SR10, the Bluetooth adapter.

1. To pair the second mobile phone, press and hold the Jog Dial for 5 seconds until the red LED flashes rapidly and you hear a voice prompt, **“Intercom pairing”**.
2. Within 2 seconds, tap the Phone Button again, then the LED flashes blue rapidly and you will hear a voice prompt, **“Second mobile phone pairing”**.
3. Search for Bluetooth devices on your mobile phone. Select the Sena 10S in the list of the devices detected on the mobile phone.
4. Enter 0000 for the PIN. Some mobile phones may not ask for the PIN.
5. The mobile phone confirms that the pairing has completed and the 10S is ready to use. You will hear a voice prompt, **“Your headset is paired”**.

Note:

1. *If you have two audio (A2DP) devices connected to your headset then the audio from one device will interrupt the audio from the other device. For example, if you are playing music from the primary mobile phone, then it can be interrupted by playing music from the secondary mobile phone and vice versa.*
2. *You have to use a motorcycle specific GPS, which transmits turn-by-turn voice instructions to the headset by Bluetooth. Most automotive GPS systems do not have this feature.*
3. *The Sena SR10 is a Bluetooth two-way radio adapter for group communication, and uses Hands-Free Profile. The incoming audio from the two-way radio via SR10 is heard in the background while having an intercom conversation or a mobile phone call.*
4. *The GPS navigation or a radar detector could be connected to the SR10 by wire. The GPS voice instruction or the radar detector alarm is also heard in the background via SR10 while having an intercom conversation or a phone call. Please refer to the SR10 User's Guide for details.*

5.3 Advanced Selective Pairing - A2DP Stereo or Handsfree

When you are using a smartphone, sometimes you may need to selectively use the 10S for A2DP stereo music only or for mobile phone handsfree only. These instructions are for advanced users who want to pair the 10S to their smartphones with only one selective profile: A2DP for stereo music or HFP for phone calls.

If you have previously paired a mobile phone to the 10S, you must clear the previous pairing list on both devices: the mobile phone and the 10S. To clear the pairing list on the 10S, please do a factory reset or following the pairing list clearing procedure described in *section 17.4, "Factory Reset"* or *14.10, "Delete All Bluetooth Pairing Information"*. To clear the pairing list on the mobile phone, please refer to *the mobile phone manual*. For most smartphones, delete the Sena 10S from the list of Bluetooth devices in the settings menu.

5.3.1 A2DP Stereo Music Only

1. Turn on the headset and press the Phone Button for 5 seconds until the LED flashes red and blue alternately and you hear multiple beeps.
2. Within 2 seconds, tap the Jog Dial again, then the LED flashes red and you hear "**Media selective pairing**".
3. Search for Bluetooth devices on your smartphone. Select the Sena 10S in the list of devices detected on your phone.
4. Enter 0000 for the PIN. Some mobile phones may not ask for PIN.

5.3.2 HFP for Phone Call Only

1. Turn on the headset and press the Phone Button for 5 seconds until the LED flashes red and blue alternately and you hear multiple beeps.
2. Within 2 seconds, tap the Phone Button again, then the LED flashes blue and you hear "**Phone selective pairing**".
3. Search for Bluetooth devices on your smartphone. Select the Sena 10S in the list of devices detected on your phone.
4. Enter 0000 for the PIN. Some mobile phones may not ask for PIN.

5.4 Intercom Pairing

5.4.1 Pairing with Other 10S Headsets for Intercom Conversation

The 10S can be paired with up to three other headsets for Bluetooth intercom conversation.

1. Turn on the two 10S headsets (A and B) that you would like to pair with each other.
2. Press and hold the Jog Dial of the headset A and B for 5 seconds until red LEDs of the both units start to flash rapidly. You will hear a voice prompt, **“Intercom pairing”**.

3. Tap the Jog Dial on any one of the two headsets A and B, and wait until the LEDs of both headsets turn to blue and intercom connection is automatically established. The two 10S headsets A and B are paired with each other for intercom conversation. If the pairing process is not completed within one minute, the 10S will return to stand-by mode.

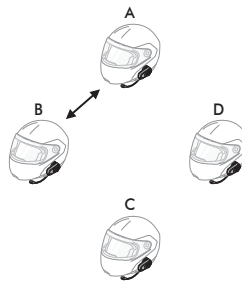

Pairing A & B

4. You can make other pairing between headsets A and C, and between headsets A and D by following the same procedure as above.
5. The intercom pairing queue is '**Last-Come, First-Served**'. If a headset has multiple paired headsets for intercom conversations, the last paired headset is set as **first intercom friend**. The previous intercom friend becomes **second intercom friend**, and **third intercom friend**.

Note:

*For example, after the pairing procedures listed above, headset D is the **first intercom friend** of headset A. Headset C is the **second intercom friend** of headset A, and headset B is the **third intercom friend** of headset A.*

5.4.2 Pairing with Other Sena Headset Models for Intercom Conversation

The 10S can be paired with all other Sena headset models such as the 20S, SMH10 and the SMH5 for intercom conversation. Please follow the same procedure as above to pair with these headset models.

Note:

The SMH5 cannot participate in three-way or four-way conference intercom with the 10S. The SMH5 has a limited capability of having two-way intercom with other Sena headsets.

6 MOBILE PHONE, GPS, SR10

6.1 Mobile Phone Call Making and Answering

1. When you have an incoming call, simply tap the Phone Button or the Jog Dial to answer the call.
2. You can also answer the incoming call by loudly speaking any word of your choice if Voice Activated Phone Answering (VOX Phone) is enabled, unless you are connected to intercom.
3. To end a call, tap the Phone Button or press the Jog Dial for 2 seconds until you hear a mid-tone single beep, or wait for the called person to end the call.
4. To reject a call, press the Jog Dial for 2 seconds until you hear a beep while the phone is ringing.
5. There are several ways to make a phone call:
 - Enter numbers on your mobile phone's keypad and make a call. Then the call is automatically transferred to the headset.
 - Tap the Phone Button in stand-by mode to activate the voice dialer of your mobile phone. For this, the voice dialing function must be available on the mobile phone. Refer to *your mobile phone manual* for further instruction.

Note:

1. If you have two phones connected to your headset and you have an incoming call from the second phone during the call of the first phone, then you may still receive the call from the second phone. In this case, the call from the first phone is on waiting mode. If you end a call, then it will automatically guide you to the first phone call.
2. If you have a mobile phone and a GPS connected to your headset, you may not be able to listen to the GPS voice instruction during the phone call.

6.2 Speed Dialing

You can quickly make a phone call by using the voice speed dial menu.

1. To enter into the voice speed dial menu, double tap the Phone Button and you will hear a mid-toned single beep and a voice prompt, “**Speed dial**”.
2. Rotate the Jog Dial clockwise or counter-clockwise to navigate between the menus. You will hear voice prompts for each menu item.

3. Tap the Phone Button or the Jog Dial to select a voice menu among the followings:

- | | |
|-------------------------------|-------------------------|
| (1) Last number redial | (4) Speed dial 3 |
| (2) Speed dial 1 | (5) Cancel |
| (3) Speed dial 2 | |

4. After selecting the last number redial menu, you will hear a voice prompt, “**Last number redial**”. Then, to redial the last phone call number, tap the Phone Button or the Jog Dial.
5. To call one of the speed dials, rotate the Jog Dial clockwise or counter-clockwise to navigate between the menus until you hear a voice prompt, “**Speed dial (#)**”. Then, tap the Phone Button or the Jog Dial.
6. If you want to exit the speed dial immediately, rotate the Jog Dial until you hear voice prompt, “**Cancel**”, and tap the Phone Button or the Jog Dial. If you do not press any button within 15 seconds, the 10S will exit the voice speed dial menu and go back to stand-by mode.

Note:

1. Make sure that you connect the mobile phone and the headset to use the speed dial function.
2. You need to assign speed dial numbers before using the speed dial (please refer to section 14.1, “Assigning Speed Dial”).

6.3 GPS Navigation

If you pair a Bluetooth GPS to the 10S as described in *section 5.2, “Second Mobile Phone Pairing - Second Mobile Phone, GPS, and SR10”*, you can listen to GPS instructions wirelessly. Rotate the Jog Dial clockwise or counter-clockwise to adjust volume. The GPS voice instruction interrupts intercom conversation but it is automatically reestablished after the GPS voice instruction ends.

6.4 Sena SR10, Two-Way Radio Adapter

You can use a two-way radio and the 10S Bluetooth intercom simultaneously by using the Sena SR10, a Bluetooth Two-way Radio Adapter (please refer to *section 5.2, “Second Mobile Phone Pairing - Second Mobile Phone, GPS, and SR10”*). Incoming audio from the two-way radio will not interrupt an intercom conversation but is heard in the background. This is useful when you have an intercom conversation with a passenger on the back seat and use a two-way radio for group communication with other motorcycle riders.

7 STEREO MUSIC

7.1 By Bluetooth Wireless Stereo

The Bluetooth audio device must be paired with the 10S by following the *section 5.1, "Mobile Phone Pairing - Mobile Phone, Bluetooth Stereo Device"* procedure. The 10S supports the Audio/Video Remote Control Profile (AVRCP), so if your Bluetooth audio device also supports the AVRCP, you can use the 10S to remotely control music playback. Not only can you adjust the volume but you can also use functions such as play, pause, next track and previous track.

1. To play or pause music, press and hold the Jog Dial for 1 second until you hear a double beep.

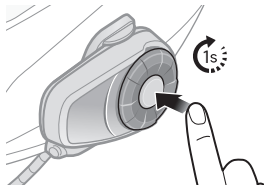

2. To adjust the volume, rotate the Jog dial.

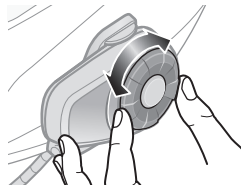

3. To track forward or track back, rotate while pressing the Jog Dial clockwise or counter clockwise.

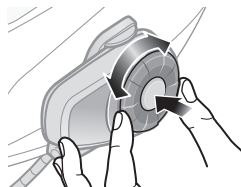

7.2 By Stereo Audio Cable

Plug your stereo MP3 player directly to the 10S by using the enclosed 3.5mm stereo audio jack cable. To adjust the volume, rotate the Jog dial on the headset. You may adjust the volume on the MP3 player also.

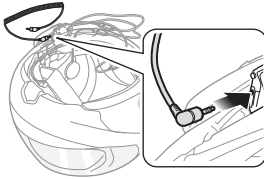

7.3 Music Sharing

You can start sharing music with an intercom friend using Bluetooth stereo music during a two-way intercom conversation (please refer to *section 8.1, "Two-way Intercom"*). When you terminate music sharing, you can go back to the intercom conversation. To start or terminate sharing music, press the Jog Dial for 1 second during an intercom conversation until you hear a double beep. To track forward or track back, rotate while pressing the Jog Dial clockwise or counter-clockwise.

Note:

1. Both you and your intercom friend can remotely control music playback such as track forward and track back.
2. Music sharing will be paused when you are using your mobile phone or listening to GPS instructions.

8 INTERCOM

Please make sure your intercom devices are paired as described in section 5.4, “Intercom Pairing”

8.1 Two-way Intercom

8.1.1 Starting Two-way Intercom

You can start an intercom conversation with one of any intercom friends by tapping the Jog Dial. Tap the Jog Dial once to intercom with the **first intercom friend**, tap the Jog Dial twice to intercom with the **second intercom friend**, and tap the Jog Dial three times to intercom with the **third intercom friend**.

8.1.2 Ending Two-way Intercom

You can end an intercom conversation by using the Jog Dial. Press and hold the Jog Dial for 1 second to end any intercom. Or, you can single tap to end intercom with the **first intercom friend**, double tap to end intercom with the **second intercom friend**, and triple tap to end intercom with the **third intercom friend**.



Start/End Two-way Intercom Conversation

8.2 Three-way Intercom

8.2.1 Starting Three-way Intercom

You (A) can have a three-way conference intercom with two other 10S friends (B & C) by establishing two intercom connections simultaneously. While a three-way conference intercom is in progress, mobile phone connection of all three participants is temporarily disconnected. However, as soon as the conference intercom terminates or one of the participants leaves the intercom, all mobile phones automatically reconnect to their headsets. If you have an incoming mobile phone call during the conference intercom, terminate the conference intercom to automatically reconnect and receive the phone call.

1. You (A) need to be paired with two other friends (B & C) for three-way conference intercom.

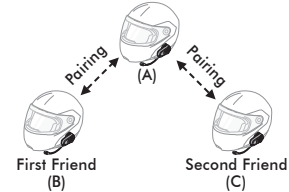

2. Start an intercom conversation with one of the two friends in your intercom group. For example, you (A) may start an intercom conversation with the intercom friend (B). Or intercom friend (B) may start an intercom call with you (A).

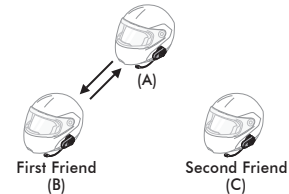

3. You (A) can call the second intercom friend (C) by double tapping the Jog Dial, or the second intercom friend (C) may join the intercom by making an intercom call to you (A).

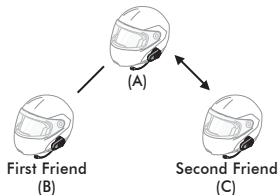

4. Now you (A) and two 10S intercom friends (B & C) are having a three-way conference intercom.

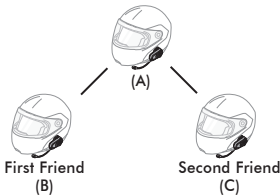

8.2.2 Ending Three-way Intercom

You can completely terminate the conference intercom or just disconnect an intercom connection with one of your active intercom friends.

1. Press the Jog Dial for 1 second until you hear a beep to terminate three-way conference intercom completely. It terminates both intercom connections with (B) and (C).
2. Tap or double tap the Jog Dial to disconnect intercom connection with one of the two intercom friends accordingly. For example, by single tapping the Jog Dial, you can terminate the intercom connection with just the first intercom friend (B). However, you still have the intercom connection with your second intercom friend (C).

Jog Dial Operation	Result
Press for 1 second	Disconnect (B) & (C)
Single tap	Disconnect (B)
Double tap	Disconnect (C)

End Three-way Intercom

8.3 Four-way Intercom

8.3.1 Starting Four-way Intercom

You can have four-way conference intercom with three other 10S users by adding one more intercom participant to the three-way intercom. While you are having a three-way intercom as above in *section 8.2, "Three-way Intercom"*, a new participant (D), who is an intercom friend of your intercom friend (C), may join the conference intercom by making an intercom call to your intercom friend (C). Please note that in this case, the new participant (D) is an intercom friend of (C), not of you (A).

8.3.2 Ending Four-way Intercom

As same in the case of three-way intercom, you can completely get out of the four-way conference intercom or just disconnect a single intercom connection.

1. Press the Jog Dial for 1 second until you hear a beep to terminate four-way conference intercom. It terminates the intercom connections between you (A), and your intercom friends (B) and (C).

2. Tap or double tap the Jog Dial to disconnect the intercom connection with one of the two intercom friends accordingly. However, when you disconnect the second friend (C) by double tapping the Jog Dial, you will be disconnected with the third participant (D) as well. This is because the third participant (D) is connected with you via the second friend (C).

Jog Dial Operation	Result
Press for 1 second	Disconnect (B), (C) & (D)
Single tap	Disconnect (B)
Double tap	Disconnect (C) & (D)

End Four-way Intercom

Note:

Multiple headsets are connected during multi-way intercom. With various signals interfering each other, the intercom distance of multi-way intercom is relatively shorter than that of two-way intercom.

9 THREE-WAY CONFERENCE PHONE CALL WITH INTERCOM PARTICIPANT

1. When you have an incoming mobile phone call during an intercom conversation, you will hear a ringtone. You can choose whether to *1) answer the mobile phone call and stop the intercom conversation, or 2) reject the phone call and stay on the intercom conversation.*
 - 1) To answer the phone call and stop the intercom conversation, tap the Phone Button or the Jog Dial. The VOX Phone feature does not work if you are connected to intercom. When you hang up the phone call, the intercom will automatically be recovered.
 - 2) To reject the phone call and stay on the intercom conversation, press the Jog Dial for 2 seconds until you hear a beep.

Unlike other motorcycle Bluetooth headsets, this prevents a user from being dropped out of an intercom conversation by an incoming mobile call.

2. When you have an incoming intercom call during a mobile phone call, you will hear 4 high toned beeps, alerting you that there is an incoming intercom call. You will also hear a voice prompt, **“Intercom requested”**. In this case, the intercom call does not override the mobile call because intercom has lower priority than mobile call. You have to hang up the mobile phone call to make or receive an intercom call.
3. You can have a three-way conference phone call by adding an intercom friend to the mobile phone conversation. During a mobile phone conversation, tap the Jog Dial to invite one of the intercom friends to the mobile phone line. To disconnect the intercom first and go back to your private mobile phone call, terminate the intercom by tapping the Jog Dial. To end the mobile phone call first and maintain the intercom conversation, tap the Phone Button, or press the Jog Dial for 2 seconds, or wait for the person on the mobile phone line to end the call.

10 GROUP INTERCOM

Group Intercom allows you to instantly create a multi-way conference intercom with three other most recently paired headsets.

1. Go through intercom pairing with up to three headsets you want to have Group Intercom with.
2. Press the Jog Dial for 3 seconds to begin Group Intercom. The LED will flash green and you will hear a voice prompt, “**Group intercom**”.
3. To terminate Group Intercom, press the Jog Dial for 1 second during Group Intercom. You will hear a voice prompt, “**Group intercom terminated**”.

Note:

Group Intercom supports 10S and 20S only. Other headsets will be excluded from Group Intercom.

11 UNIVERSAL INTERCOM

You can have an intercom conversation with non-Sena Bluetooth headsets using the Universal Intercom function. Non-Sena Bluetooth headsets can be connected to the Sena Bluetooth headset if they support the Bluetooth Hands-Free Profile (HFP). The working distance may differ depending on the performance of Bluetooth headset that it is connected to. In general, it is shorter than normal intercom distance since it uses the Bluetooth Hands-Free Profile. The Universal Intercom affects both the phone call connection and the multipoint connection (mostly used for GPS connections for riders). You cannot use a multipoint connection device while you are using the Universal Intercom in case as below.

1. If a non-Sena headset does not support a multipoint connection, it cannot use a phone call connection while using the Universal Intercom.
2. As for Sena headsets, the Universal Intercom affects the multipoint connection.
3. If non-Sena headset (already paired as Universal Intercom with Sena) is turned on, then the multipoint connection is automatically deactivated. And the non-Sena headset is automatically connected to Sena headset as a Universal Intercom. So you cannot use multipoint connection devices such as GPS, while a non-Sena headset is turned on.
4. Even though you disconnect the non-Sena headset as a Universal Intercom, it will not automatically restore the multipoint connection. To restore the multipoint connection, you should turn off the non-Sena headset first, then try to connect to multipoint device manually from the device screen or simply reboot the device so that it automatically connects to the Sena headset.

11.1 Universal Intercom Pairing

The 10S can be paired with non-Sena Bluetooth headsets for Bluetooth intercom conversation. You can pair the 10S with only one non-Sena Bluetooth headset so if you pair with a different non-Sena Bluetooth headset, the previous pairing will be removed.

1. Turn on the 10S and a non-Sena Bluetooth headset that you want to pair with.
2. Press the Jog Dial for 10 seconds to enter the configuration menu. Rotate the Jog Dial until you hear a voice prompt, **“Universal intercom pairing”**. Tap the Phone Button to enter into Universal Intercom Pairing mode and the blue LED will flash rapidly and you will hear multiple beeps. Please refer to *section 14.12, “Universal Intercom Pairing”* for more details.
3. Perform the operation required for handsfree pairing on the non-Sena Bluetooth headset (refer to *the User’s Guide for the headsets* you want to use). The 10S will automatically pair with a non-Sena Bluetooth headset when each are in pairing mode.

11.2 Two-way Universal Intercom

You can initiate the Universal Intercom connection with non-Sena Bluetooth headsets using the same intercom connection method as you would between other Sena headsets. You may single tap the Jog Dial to begin an intercom conversation with the first intercom friend, double tap with the second intercom friend, and triple tap with the third intercom friend.

Non-Sena Bluetooth headsets may initiate the Universal Intercom connection, by activating the voice dialer or using the redialing operation. You may also disconnect the existing connection by using the operation to end a call (refer to *the User's Guide of the headsets* for voice dialer, redialing, and ending a call).

11.3 Three-way Universal Intercom

You may make a three-way Universal Intercom connection with two 10Ss and one non-Sena Bluetooth headset. If the intercom connection is made, all headsets connected cannot use the mobile phone call function since the connection between the headset and the phone is disconnected temporarily. If you disconnect the intercom call, the mobile phone connection is made again automatically so that you can use a mobile phone call function.

1. You (A) need to be paired with a non-Sena Bluetooth headset (B) and another 10S headset (C) for the three-way conference intercom.

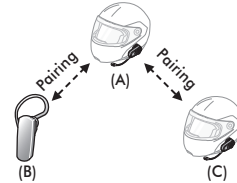

2. Start an intercom conversation with non-Sena Bluetooth headset (B) in your intercom group. For example, you (A) may start an intercom conversation with non-Sena Bluetooth headset (B). The non-Sena Bluetooth headset (B) may also start an intercom call with you (A).

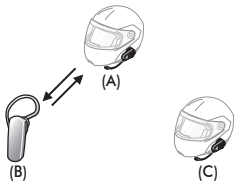

3. The other 10S (C) may join the intercom by making an intercom call to you (A).

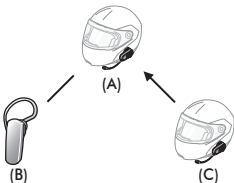

4. Now you (A), non-Sena Bluetooth headset (B), and the other 10S (C) are having a three-way conference intercom.

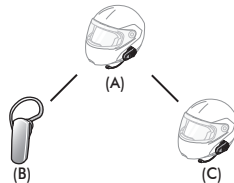

5. You may disconnect three-way Universal Intercom using the same way as you do in normal three-way intercom. Please refer to *section 8.2.2, "Ending Three-way Intercom"*.

11.4 Four-way Universal Intercom

You may make a four-way Universal Intercom connection with a couple of different configurations, 1) *three 10Ss and one non-Sena Bluetooth headset* or 2) *two 10Ss and two non-Sena Bluetooth headsets*.

You may have a couple of other Four-way Universal Intercom configurations, 1) *your headset (A), a non-Sena Bluetooth headset (B), another 10S (C), and a non-Sena Bluetooth headset (D)*, 2) *your headset (A), a non-Sena Bluetooth headset (B), and two other 10S headsets (C and D)*. You may make the four-way Universal Intercom call the same way as a normal four-way intercom call.

11.4.1 Four-way Universal Intercom Case 1

Two 10S headsets (A and C) and two non-Sena Bluetooth headsets (B and D)

1. You (A) may start an intercom conversation with the non-Sena Bluetooth headset (B).

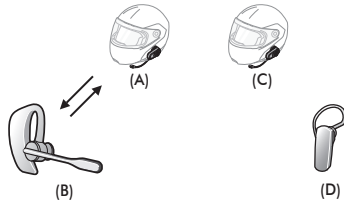

2. The other 10S (C) may join the intercom by making an intercom call to you (A).

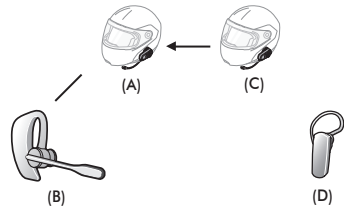

3. The non-Sena Bluetooth headset (D) may join the conference intercom by making an intercom call to the 10S (C).

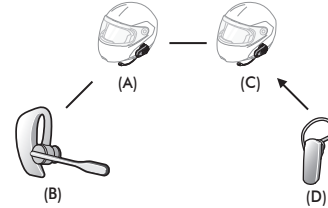

4. Now two 10S headsets (A & C) and two non-Sena Bluetooth headsets (B & D) are connected with the four-way Universal Intercom.

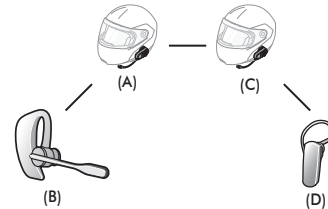

You may disconnect a four-way Universal Intercom using the same way as you do in a normal four-way intercom. Please refer to *section 8.3.2, "Ending Four-way Intercom"*.

11.4.2 Four-way Universal Intercom Case 2

Three 10S headsets (A, C and D) and one non-Sena Bluetooth headset (B). The procedure is the same as case 1 described in *section 11.4.1*, “Four-way Universal Intercom Case 1”.

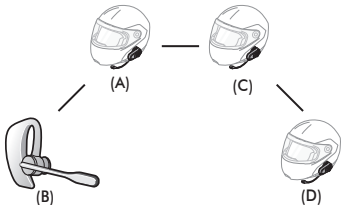

12 FM RADIO

12.1 FM Radio On and Off

To turn on the FM radio, press the Phone Button for 1 second until you hear a mid-toned double beep sound. You will then hear a voice prompt, “**FM on**”. To turn off the FM radio, press the Phone Button for 1 second until you hear a voice prompt, “**FM off**”. When you power it off, the 10S will remember the last station frequency. When you power it on, the last station frequency will be playing.

12.2 Preset Stations

You can listen to preset stations while listening to the FM radio. Tap the Phone Button once to go upward to your next saved preset station.

12.3 Seek and Save

“Seek” is the function that searches for station to station frequencies. To use the “Seek” function, please follow the procedure below:

1. Rotate while pressing the Jog Dial clockwise or counter-clockwise to search down or up the station dial.
2. If the tuner finds a station while searching frequencies, it stops the seek function.
3. To save the current station, press and hold the Jog Dial for 1 second until you hear a voice prompt, **“Preset (#)”**.
4. Rotate the Jog Dial in order to select which preset number you want for that specific station. You can save up to 10 preset stations. (You may cancel the preset operation by waiting approximately 10 seconds. You will then hear **“Save preset cancelled”**. You can also rotate the Jog Dial until you hear **“Cancel”**. Tap the Jog Dial to confirm cancellation. You will then hear **“Save preset cancelled”**.)
5. To save the current station, tap the Jog Dial again. You will then hear a voice prompt, **“Save preset (#)”**.
6. To delete the saved station in the preset number, tap the Phone Button. You will then hear a voice prompt, **“Delete preset (#)”**.

Note:

1. You can save FM stations to presets before using FM radio. Connect the 10S to your PC and open the Sena Device Manager. It allows you to save up to 10 FM station frequency presets on the 10S settings menu. You may do the same operation by using the Sena Smartphone App.
2. You can still answer an incoming phone call and intercom while listening to the FM radio.

12.4 Scan and Save

“Scan” is the function that automatically searches station frequencies, starting from the current frequency and up. To use the scan function, please follow the procedures below:

1. Double tap the Phone Button. Then the current station frequency moves upward to find other station frequencies.
2. If the tuner finds a station, it stays at the station frequency for 8 seconds, then scanning to the next station frequency.
3. Scan function stops when you double tap the Phone Button again.
4. To save a station while scanning frequencies, tap the Phone Button when at that station. You will hear a voice prompt from the 10S, **“Save preset (#)”**. The station will be saved as the next preset number.
5. All stations preset during “Scan”, will overwrite previously set stations.

12.5 Temporary Preset

With the temporary preset function, you may temporarily preset stations automatically without changing the existing preset stations. Tap the Phone Button three times to automatically scan for 10 temporary preset stations. The temporary preset stations will be cleared when the system is powered off.

12.6 Region Selection

You can select the proper FM frequency region from the Sena Device Manager. With the region setting, you may optimize the seek function to avoid unnecessary frequency ranges (factory default: worldwide).

Region	Frequency range	Step
Worldwide	76.0 ~ 108.0 MHz	± 100 kHz
Americas	87.5 ~ 107.9 MHz	± 200 kHz
Asia	87.5 ~ 108.0 MHz	± 100 kHz
Australia	87.5 ~ 107.9 MHz	± 200 kHz
Europe	87.5 ~ 108.0 MHz	± 100 kHz
Japan	76.0 ~ 95.0 MHz	± 100 kHz

13 FUNCTION PRIORITY

The 10S operates in the following order of priority:

(highest)

Mobile phone

Intercom

Music sharing by Bluetooth stereo music

FM Radio

Stereo music by audio cable

(lowest)

Bluetooth stereo music

A lower priority function is always interrupted by a higher priority function. For example, stereo music is interrupted by intercom call, and an intercom conversation is interrupted by an incoming mobile phone call.

14 CONFIGURATION SETTING

You can set the configuration of the 10S by the voice menu instruction described below.

1. To enter into voice configuration menu, press and hold the Jog Dial for 10 seconds until the LED shows solid blue and you hear high toned double beeps. You will also hear a voice prompt, “**Configuration menu**”.
2. Rotate the Jog Dial to navigate between the menus. You will hear voice prompts for each menu item as below.
3. You can enable the feature or execute the command by tapping the Phone Button, or disable the feature by tapping the Jog Dial.
4. If no button is pressed within 10 seconds, the 10S will exit the configuration and go back to stand-by mode.
5. If you want to exit the configuration immediately, rotate the Jog Dial until you hear a voice prompt, “**Exit configuration**”, and tap the Phone Button.

The voice prompt for each menu item is as below:

- | | |
|-------------------------|--|
| (1) <i>Speed dial</i> | (8) <i>Sidetone</i> |
| (2) <i>Audio boost</i> | (9) <i>Noise control</i> |
| (3) <i>VOX phone</i> | (10) <i>Delete all pairings</i> |
| (4) <i>VOX intercom</i> | (11) <i>Remote control pairing</i> |
| (5) <i>HD intercom</i> | (12) <i>Universal Intercom Pairing</i> |
| (6) <i>Voice prompt</i> | (13) <i>Exit configuration</i> |
| (7) <i>RDS AF set</i> | |

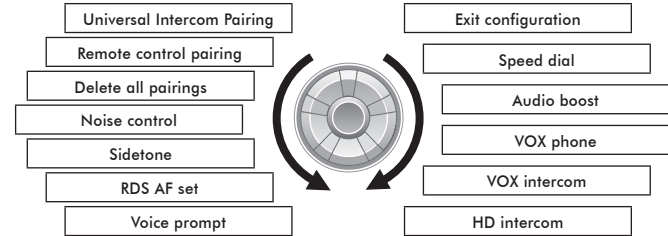

14.1 Assigning Speed Dial

Voice Prompt	“Speed dial”
Factory Default	N/A
Execute	Tap the Phone Button

1. To assign a phone number as a speed dial, rotate the Jog Dial until you hear a voice prompt, “**Speed dial**”.
2. Tap the Phone Button, and you will hear a voice prompt, “**Speed dial one**” and “**Phone connected**”.
3. Rotate the Jog Dial to select one of three speed dial numbers and you hear a voice prompt, “**Speed dial (#)**”.
4. Call a phone number you want to assign and you will hear a voice prompt, “**Save speed dial (#)**”. The phone number is automatically assigned to the selected speed dial number. Then the phone call will hang up before being connected.
5. To exit the menu, rotate the Jog Dial until you hear a voice prompt, “**Cancel**”, and tap the Phone Button to confirm. You will then hear a voice prompt, “**Cancel**”. If no button is pressed within 1 minute, the 10S will exit the configuration menu and go back to stand-by mode.

Note:

1. After assigning a phone number to one of three speed dials, you can continually assign another phone number to the rest of two speed dials.
2. You can also assign phone numbers for speed dialing by using the Sena Device Manager software or the Sena Smartphone App. Please visit the Sena Bluetooth website at www.sena.com for more information.

14.2 Enabling/Disabling Audio Boost

Voice Prompt	“Audio boost”
Factory Default	Disable
Enable	Tap the Phone Button
Disable	Tap the Jog Dial

Enabling Audio Boost increases the overall maximum volume. Disabling Audio Boost reduces the overall maximum volume, but delivers more balanced sound.

14.3 Enabling/Disabling Voice Activated Phone Answering

Voice Prompt	“VOX phone”
Factory Default	Enable
Enable	Tap the Phone Button
Disable	Tap the Jog Dial

If this feature is enabled, you can answer incoming calls by voice. When you hear a ringtone for an incoming call, you can answer the phone by saying a word such as **“Hello”** loudly or by blowing air into the microphone. VOX phone is temporarily disabled if you are connected to intercom. If this feature is disabled, you have to tap the Phone Button to answer an incoming call.

14.4 Enabling/Disabling Voice Activated Intercom

Voice Prompt	“VOX intercom”
Factory Default	Disable
Enable	Tap the Phone Button
Disable	Tap the Jog Dial

If this feature is enabled, you can initiate an intercom conversation with the last connected intercom friend by voice. When you want to start intercom, say a word such as **“Hello”** loudly or blow air into the microphone. If you start an intercom conversation by voice, the intercom terminates automatically when you and your intercom friend remain silent for 20 seconds. However, if you manually start an intercom conversation by tapping the Phone Button, you have to terminate the intercom conversation manually.

However, if you start intercom by voice and end it manually by tapping the Jog Dial, you will not be able to start intercom by voice temporarily. In this case, you have to tap the Jog Dial to restart the intercom. This is to prevent repeated unintentional intercom connections by strong wind noise. After rebooting the 10S, you can start intercom by voice again.

14.5 Enabling/Disabling HD Intercom

Voice Prompt	“HD intercom”
Factory Default	Enable
Enable	Tap the Phone Button
Disable	Tap the Jog Dial

HD Intercom enhances the two-way intercom audio from normal quality to HD quality. HD Intercom will become temporarily disabled when you enter into a multi-way intercom. If this feature is disabled, the two-way intercom audio will change to normal quality.

Note:

The intercom distance of HD Intercom is relatively shorter than that of normal intercom.

14.6 Enabling/Disabling Voice Prompts

Voice Prompt	“Voice prompt”
Factory Default	Enable
Enable	Tap the Phone Button
Disable	Tap the Jog Dial

You can disable voice prompts by configuration setting, but the following voice prompts are always on.

- Voice prompts for configuration setting menu
- Voice prompts for battery level indicator
- Voice prompts for speed dial
- Voice prompts for FM radio functions

14.7 Enabling/Disabling RDS AF

Voice Prompt	“RDS AF setting”
Factory Default	Disable
Enable	Tap the Phone Button
Disable	Tap the Jog Dial

RDS AF allows a receiver to re-tune to the second frequency location when the first signal becomes too weak. With RDS AF enabled on the receiver, a radio station with more than one frequency can be used.

14.8 Enabling/Disabling Sidetone

Voice Prompt	“Sidetone”
Factory Default	Disable
Enable	Tap the Phone Button
Disable	Tap the Jog Dial

Sidetone is audible feedback of your own voice. It helps you to naturally speak at the correct level according to varying helmet noise conditions. If this feature is enabled, you can hear what you are speaking during an intercom conversation or a phone call.

14.9 Enabling/Disabling Advanced Noise Control™

Voice Prompt	“Noise control”
Factory Default	Enable
Enable	Tap the Phone Button
Disable	Tap the Jog Dial

When Advanced Noise Control is enabled, the background noise is reduced during an intercom conversation. When it is disabled, the background noise is mixed with your voice during intercom.

Note:

If you use your 10S with the Bluetooth Audio Pack for GoPro, you can enable or disable this feature only during Normal Audio Recording Mode. This feature is automatically disabled while in Ultra HD (UHD) Audio Mode.

14.10 Delete All Bluetooth Pairing Information

Voice Prompt	“Delete all pairings”
Factory Default	N/A
Execute	Tap the Phone Button

To delete all Bluetooth pairing information of the 10S, rotate the Jog Dial until you hear a voice prompt, **“Delete all pairings”**, and tap the Phone Button to confirm.

14.11 Remote Control Pairing

Voice Prompt	“Remote control pairing”
Factory Default	N/A
Execute	Tap the Phone Button

To enter into Remote Control Pairing mode, rotate the Jog Dial until you hear a voice prompt, **“Remote control pairing”**. Then tap the Phone Button to enter into Remote Control Pairing mode. The headset will automatically exit from the configuration menu.

14.12 Universal Intercom Pairing

Voice Prompt	“Universal intercom pairing”
Factory Default	N/A
Execute	Tap the Phone Button

To enter into Universal Intercom Pairing mode, rotate the Jog Dial until you hear a voice prompt, **“Universal intercom pairing”**. Then press the Phone Button to enter into Universal Intercom Pairing mode. The headset will automatically exit from the configuration menu.

14.13 Exit Voice Configuration Menu

Voice Prompt	“Exit configuration”
Factory Default	N/A
Execute	Tap the Phone Button

To exit voice configuration menu and get back to stand-by mode, rotate the Jog Dial until you hear a voice prompt, **“Exit configuration”**, and tap the Phone Button to confirm.

Rotate Jog Dial	Tap Phone Button	Tap Jog Dial
Speed Dial	Execute	N/A
Audio Boost	Enable	Disable
VOX Phone	Enable	Disable
VOX Intercom	Enable	Disable
HD Intercom	Enable	Disable
Voice Prompt	Enable	Disable
RDS AF Setting	Enable	Disable
Sidetone	Enable	Disable
Advanced Noise Control	Enable	Disable
Delete All Pairings	Execute	N/A
Remote Control Pairing	Execute	N/A
Universal Intercom Pairing	Execute	N/A
Exit Configuration	Execute	N/A

Voice Configuration Menu & Button Operations

15 REMOTE CONTROL

You can remotely control the 10S via Bluetooth using the Handlebar Remote (sold separately). This eliminates the need to take off your hand for button operations. Your 10S and the Handlebar Remote must be paired together before use.

15.1 Pairing with the Handlebar Remote

1. Turn on the 10S and the Handlebar Remote.
2. Press the Jog Dial for 10 seconds to enter the configuration menu. Rotate the Jog Dial until you hear a voice prompt saying, **“Remote control pairing”**. Press the Phone Button to enter into Remote Control Pairing mode and the red LED will flash rapidly and you will hear multiple beeps. Please refer to *section 14.11, “Remote Control Pairing”* for more details.
3. On the Handlebar Remote, press the Rear Button for 5 seconds until its LED flashes red and blue. The 10S will automatically perform pairing with the Handlebar Remote in pairing mode. You will hear a voice prompt, **“Remote control connected”**, when they are successfully connected.

15.2 Using the Handlebar Remote

Handlebar Remote button operations on various functions are described in the table below.

Type	Function	Handlebar Remote	LED
Basic Function	Volume adjustment	Move the Joystick up or down	-
	Configuration menu	Press the Front Button for 10 seconds	-
Mobile Phone	Mobile phone pairing	Press the Joystick for 5 seconds	Blue & red alternatively flashing
	Second mobile phone pairing	Press the Front Button for 5 seconds	Red flashing
		Tap the Rear Button within 2 seconds	
	Answer/End phone call	Tap the Rear Button	-
	Voice dial	Tap the Rear Button	-
	Speed dial	Double tap the Rear Button	-
	Reject incoming call	Press the Front Button for 2 seconds	-

Type	Function	Handlebar Remote	LED
Intercom	Intercom pairing	Press the Front Button for 5 seconds	Red flashing
		Tap the Front Button of any one of the two headsets	
	Start/End each intercom	Tap the Front Button	-
	End all intercoms	Press the Front Button for 1 second	-
	Start Group intercom	Press the Front Button for 3 seconds	Green flashing
Music	End Group intercom	Press the Front Button for 1 second	-
	Play/Pause Bluetooth music	Press the Joystick for 1 second	-
	Track forward/back	Move the Joystick left or right for 1 second	-
FM radio	FM radio on/off	Press the Rear Button for 1 second	-
	Select preset	Tap the Rear Button	-
	Seek stations	Move the Joystick left or right for 1 second	-
	Scan up FM band	Double tap the Rear Button	-
	Stop scanning	Double tap the Rear Button	-
	Save preset while scanning	Tap the Rear Button	-

Handlebar Remote Button Operation Table

16 FIRMWARE UPGRADE

The 10S supports firmware upgrades. You can update the firmware using the Sena Device Manager (please refer to *section 4.7.1*, “Sena Device Manager”). Please visit Sena Bluetooth website at www.sena.com to check the latest software downloads.

17 TROUBLESHOOTING

17.1 Intercom Failure

When you try to start an intercom conversation with an intercom friend who is unavailable within range or already having a conference intercom with other riders or a mobile phone call, you will hear a low tone double beep signifying an intercom busy signal. In this case, you have to try again later.

17.2 Intercom Reconnection

If your intercom friend goes out of range while having an intercom conversation, you may hear static noise and eventually the intercom will be disconnected. In this case, the 10S automatically tries to reconnect the intercom every 8 seconds and you will hear high tone double beeps until the intercom is reestablished. If you do not want to make a reconnection, tap the Jog Dial to stop the attempt.

17.3 Fault Reset

When the 10S is not working properly or is in faulty status for any reason, you may reset by pushing the pin-hole reset button. Insert a paper clip into the reset pin-hole and press the reset button for a second with light pressure. The 10S will be switched off. Restart the system and try again. This will not restore the headset to factory default settings.

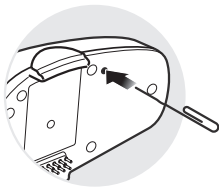

17.4 Factory Reset

1. To restore the 10S to factory default settings, press and hold the Phone Button for 10 seconds until the LED shows solid red and you hear **“Factory reset”**.
2. Within 10 seconds, press the Jog Dial to confirm reset. The headset will be restored to factory setting and switched off automatically. You will hear, **“Headset reset, goodbye”**.
3. If you press the Phone Button or leave the Jog Dial for 10 seconds, the reset attempt is cancelled and the headset returns to stand-by mode. You will hear a voice prompt, **“Cancelled”**.

18 OPERATION QUICK REFERENCE

Type	Function	Button Command	LED	Beep
Basic Function	Power on	Press the Phone Button and the Jog Dial for 1 second	Solid blue	Ascending beeps
	Power off	Press the Phone Button and the Jog Dial	Solid red	Descending beeps
	Volume adjustment	Rotate the Jog Dial	-	-
Mobile Phone	Mobile phone pairing	Press the Phone Button for 5 seconds	Blue & red alternatively flashing	High tone multiple beeps
	Second mobile phone pairing	Press the Jog Dial for 5 seconds	Red flashing	Multiple beeps
		Tap the Phone Button within 2 seconds		
	Answer mobile phone call	Tap the Phone Button or the Jog Dial	-	-
	End mobile phone call	Tap the Phone Button or press the Jog Dial for 2 seconds	-	-
	Voice dial	Tap the Phone Button	-	-
	Speed dial	Double tap the Phone Button	-	Mid-tone single beep
	Reject incoming call	Press the Jog Dial for 2 seconds	-	-

Type	Function	Button Command	LED	Beep
Intercom	Intercom pairing	Press the Jog Dial for 5 seconds	Red flashing	Mid-tone single beep
		Tap the Jog Dial of any one of the two headsets		
	Start/End each intercom	Tap the Jog Dial	-	-
	End all intercoms	Press the Jog Dial for 1 second	Blue flashing	Mid-tone double beeps
	Start Group intercom	Press the Jog Dial for 3 seconds	Green flashing	-
End Group intercom	Press the Jog Dial for 1 second	-	-	
Music	Play/Pause Bluetooth music	Press the Jog Dial for 1 second	-	Mid-tone double beep
	Track forward/back	Rotate the Jog Dial while pressing	-	-

Type	Function	Button Command	LED	Beep
FM Radio	FM radio on/off	Press the Phone Button for 1 second	-	Mid-tone double beeps
	Select preset	Tap the Phone Button	-	Mid-tone single beep
	Seek stations	Rotate the Jog Dial while pressing	-	High tone triple beeps
	Scan up FM band	Double tap the Phone Button	-	-
	Stop scanning	Double tap the Phone Button	-	High tone double beeps
	Save preset while scanning	Tap the Phone Button	-	High tone double beeps
Reset	Factory reset	Press the Phone Button for 10 seconds	Solid red	High tone double beeps
		Tap the Jog Dial within 10 seconds		
	Fault reset	Press the Reset Button	-	-

CERTIFICATION AND SAFETY APPROVALS

FCC Compliance Statement

This device complies with part 15 of the FCC rules. Operation is subject to the following two conditions:

- (1) This device may not cause harmful interference, and
- (2) This device must accept any interference received, including interference that may cause undesired operation.

This equipment has been tested and found to comply with the limits for a Class B digital device pursuant to part 15 of the FCC rules. These limits are designed to provide reasonable protection against harmful interference in a residential installation. This equipment generates, uses and can radiate radio frequency energy and, if not installed and used in accordance with the instructions, may cause harmful interference to radio communications. However, there is no guarantee that interference will not occur in a particular installation. If this equipment does cause harmful interference to radio or television reception, which can be determined by turning the equipment on and off, the user is encouraged to try to correct the interference by one or more of the following measures:

- Reorient or relocate the receiving antennae
- Increase the separation between the equipment and the receiver

- Connect the equipment into an outlet on a circuit different from that to which the receiver is connected
- Consult the dealer or an experienced radio/TV technician for help

FCC RF Exposure Statement

This equipment complies with FCC radiation exposure limits set forth for an uncontrolled environment. End users must follow the specific operating instructions for satisfying RF exposure compliance. The antenna used for this transmitter must not transmit simultaneously with any other antenna or transmitter, except in accordance with FCC multi-transmitter product procedures.

FCC Caution

Any changes or modifications to the equipment not expressly approved by the party responsible for compliance could void user's authority to operate the equipment.

CE Declaration of Conformity

This product is CE marked according to the provisions of the R&TTE Directive (1999/5/EC). Hereby, Sena declares that this product is in compliance with the essential requirements and other relevant provisions of Directive 1999/5/EC. For further information, please consult www.sena.com. Please note that this product uses radio frequency bands not harmonized within EU. Within the EU this product is intended to be used in Austria, Belgium, Denmark, Finland, France, Germany, Greece, Ireland, Italy, Luxembourg, The Netherlands, Portugal, Spain, Sweden, United Kingdom and within EFTA in Iceland, Norway and Switzerland.

Industry Canada Statement

This device complies with Industry Canada license-exempt RSS standard(s). Operation is subject to the following two conditions:

- (1) This device may not cause interference.
- (2) This device must accept any interference, including interference that may cause undesired operation of the device.

Bluetooth License

The Bluetooth® word mark and logos are owned by the Bluetooth SIG, Inc. and any use of such marks by Sena is under license. Other trademarks and trade names are those of their respective owners.

The product is compliant with and adopts the Bluetooth® Specification 4.1 and has successfully passed all interoperability tests that are specified in the Bluetooth® specification. However, interoperability between the device and other Bluetooth®-enabled products is not guaranteed.

WEEE (Waste Electrical and Electronic Equipment)



The crossed-out wheel bin symbol on the product, literature, or packaging reminds you that all electrical and electronic products, batteries, and accumulators must be taken to separate collection at the end of their working life. This requirement applies to the European Union and other locations where separate collection systems are available. To prevent possible harm to the environment or human health from uncontrolled waste disposal, please do not dispose of these products as unsorted municipal waste, but hand it in at an official collection point for recycling.

SAFETY INFORMATION

Please ensure that the product is properly used by observing the warnings and cautions below to prevent any risk and/or damage to property.

Product Storage and Management

- Keep the product free of dust. It may damage mechanical and electronic parts of the product.
- Do not store the product in high temperatures as this may reduce the life span of electronic devices, damage the battery, and/or melt plastic parts of the product.
- Do not store the product in cold temperatures. Abrupt changes in temperatures may cause condensation and damage electronic circuits.
- Do not clean the product with cleaning solvents, toxic chemicals, or strong detergents as this may damage the product.
- Do not paint the product. Paint may obstruct moving parts or interfere with the normal operation of the product.
- Do not drop or otherwise shock the product. It may damage the product or its internal electronic circuits.
- Do not disassemble, repair or modify the product as this may damage the product and invalidate the product warranty.

- Do not store the product in humid environments, especially for long time storage.

Product Use

- In some regions, it is prohibited by law to ride motorcycles while wearing headsets or earbuds. Therefore be certain to comply with all relevant laws in the region before using the product.
- The headset is for motorcycle helmets only. To install the headset, you must follow the installation instructions shown in the User's Guide.
- Use of the product at a high volume for a long period of time may damage your eardrums or hearing ability. Keep the volume at a modest level to prevent damage.
- Do not cause impact to the product or touch it with sharp tools as this may damage the product.
- Do not use the product in high-temperatures or apply heat to the product as this may cause damage, explosion, or fire.
- Keep product away from pets or small children. It may damage the product.
- In any place where wireless communication is prohibited, such as hospitals or airplanes, turn off the power and refrain from using the product. In a place where wireless communication is prohibited, electromagnetic waves may cause hazards or accidents.

- Do not use the product near hazardous explosives. When it is near any explosion hazards, turn off the power and heed any regulations, instructions, and signs in the area.
- When using the product, be certain to conform to laws regarding the use of communications devices while riding.
- Do not put the product where it may hamper the rider's vision or manipulate it while riding. This may cause traffic accidents.
- Before riding, fasten the product to the helmet, and double-check that it is fastened. Separation of the product while riding may cause damage to the product or accidents.
- If the product is damaged, stop using it immediately. It may cause damage, explosion, or fire.

Battery

This product has an irreplaceable rechargeable battery inside. Therefore, when using the product, make sure to adhere to the following:

- Never separate the battery from the product as this may damage the product.
- The battery performance may be reduced over time with usage.

- In recharging the battery, make sure to use an approved charger provided by the manufacturer. Use of a non-approved charger may cause fire, explosion, leakage, and other hazards may also reduce the life time or performance of the battery.
- Any 3rd party USB charger can be used with Sena products if the charger is approved by either the FCC, CE, IC or other locally approved agencies that Sena accepts.
- Do not use cigarette chargers other than the included cigarette charger to charge the headset.
- Store the battery at temperatures of 15°C~25°C (59°F~77°F). Higher or lower temperatures may reduce the capacity and life of the battery, or may cause temporary non-operation. Do not use the product in sub-zero temperature, because it may cause serious reduction of the battery performance.
- If you apply heat to the battery or throw it into fire, it may explode.
- Do not use the product with a damaged battery. It may explode and/or cause accidents.
- Never use a damaged charger. It may explode and/or cause accidents.
- Battery life may vary depending on conditions, environmental factors, functions of the product in use, and devices used with it.

PRODUCT WARRANTY AND DISCLAIMER

Limited Warranty

Limited Warranty

Sena Technologies, Inc. (“Sena”) guarantees the product quality based on the technical specification stated in the product manual, and data regarding product warranty. Here, product warranty extends to the product only. Sena will not be liable for any loss, damage of human life, or loss of property which may result from using the product beyond defective parts or flaws that occur due to problems in manufacture.

Warranty Period

Sena guarantees free-of-charge replacements of defective parts of the product or flaws that may have occurred due to problems in manufacture for a period of 2 years from the date of initial purchase.

Termination

Quality warranty of the product becomes effective on the date of initial purchase. In addition, the quality warranty of the product expires when the warranty period expires. However, in the following cases, the warranty will be terminated prematurely.

- In the event the product has been sold or transferred to a third party.
- In the event the manufacturer’s name, serial number, product label, or other markings have been modified or removed.

- In the event any unauthorized person has tried to disassemble, repair, or modify the product.

Notice and Waiver

By buying and using this product, you relinquish considerable legal rights including any claim for compensation for damages. Therefore, be certain to read and understand the following terms and conditions before using the product. Use of this product will constitute consent to this agreement, and forfeiture of rights to all claims. If you do not consent to all the terms and conditions of this agreement, return the product for a refund.

1. You agree that you, your descendants, legal proxies, successors, or transferees will not raise permanent volitional request for any suit, claim, implementation, redemption or similar action from Sena with regard to any occasion such as difficulty, pain, suffering, inconvenience, loss, injury, or death which may occur to you or a third party during the use of this product.
2. You must completely understand and accept all risks (including those occurring due to any careless behavior of yours or others) which may occur during the use of this product.
3. You are responsible for ensuring that your medical condition permits usage of the product and that you are in sufficient physical condition for using any device which can be used with it. In addition, you must ensure that the product does not limit your abilities and that you are able to use it safely.

4. You must be an adult who can take responsibilities for using the product.
5. You must read and understand the following warnings and alerts:
 - Sena; together with employees, managers, partners, subsidiaries, representatives, agents, supporting firms and suppliers, sole sellers of Sena (collectively referred to as “the company”) recommend that, before using the product and similar devices of any brands including its derivative models, you collect any relevant information in advance and be entirely prepared in terms of weather, traffic situation, and road conditions.
 - When you use the product while you operating any vehicle or equipment such as motorcycles, scooters, mopeds, ATVs, or quad-bikes (hereinafter called as “transportation means”), you must take complete caution regardless of the location of such operation.
 - Use of the product on the road may cause such risks as fracture, serious disability, or death.
 - Risk factors, which may occur when you use the product, may be due to errors of the manufacturer, its agents, or third parties which are involved in the manufacturing.

- Risk factors, which may occur when you use the product, may be unforeseeable. Therefore, you must take full responsibility for any damage or loss caused by all risk factors which may occur when using the product.
 - When you use the product, use good judgment; never use it under the influence of alcohol.
6. You must read and completely understand all terms and conditions of legal rights and warnings that are involved in using the product. In addition, usage of the product constitutes acceptance of all terms and conditions regarding waiver of rights.

Warranty Exclusions

Reasons for Limited Liabilities

If you do not return the product after purchasing it, you relinquish all rights to liabilities, loss, claims, and claims for reimbursement of expenses (including attorney's fees). Therefore, Sena will not be liable for physical injury, death, or any loss or damage of transportation means, possessions, or assets which belong to you or third parties that may have occurred while you use the product. Further, Sena will not be liable for any substantial damage not related to the condition, environment, or malfunction of the product. All risks related with the operation of the product depend entirely on the user regardless of its use by the initial purchaser of a third party.

Use of this product may violate local or national laws. In addition, be aware once again that correct and safe use of the product is entirely your responsibility.

Limitation of Liability

TO THE FULL EXTENT ALLOWED BY LAW, SENA EXCLUDES FOR ITSELF AND ITS SUPPLIERS ANY LIABILITY, WHETHER BASED IN CONTRACT OR TORT (INCLUDING NEGLIGENCE), FOR INCIDENTAL, CONSEQUENTIAL, INDIRECT, SPECIAL, OR PUNITIVE DAMAGES OF ANY KIND, OR FOR LOSS OF REVENUE OR PROFITS, LOSS OF BUSINESS, LOSS OF INFORMATION OR DATA, OR OTHER FINANCIAL LOSS ARISING OUT OF OR IN CONNECTION WITH THE SALE, INSTALLATION, MAINTENANCE, USE, PERFORMANCE, FAILURE, OR INTERRUPTION OF ITS PRODUCTS, EVEN IF SENA OR ITS AUTHORIZED RESELLER HAS BEEN ADVISED OF THE POSSIBILITY OF SUCH DAMAGES, AND LIMITS ITS LIABILITY TO REPAIR, REPLACEMENT, OR REFUND OF THE PURCHASE PRICE PAID, AT SENA'S OPTION. THIS DISCLAIMER OF LIABILITY FOR DAMAGES WILL NOT BE AFFECTED IF ANY REMEDY PROVIDED HEREIN SHALL FAIL OF ITS ESSENTIAL PURPOSE. IN ANY CASE, THE TOTAL COMPENSATION LIABILITIES OF SENA OR ITS SALES AGENTS SHALL NOT EXCEED THE PRICE PAID FOR THE PRODUCT BY THE PURCHASER.

Liabilities Disclaimer

In addition to damages which may occur due to the use of the product, Sena will not be liable for damages of the product which occur due to the following events.

- In the event the product is misused or used for purposes other than its intended purposes.
- In the event the product is damaged because the user does not follow the content of the product manual.
- In the event the product is damaged because it has been left unattended or has undergone any other accident.
- In the event the product is damaged because the user has used any parts or software which are not provided by the manufacturer.
- In the event the product is damaged because the user has disassembled, repaired, or modified it in such way as is not explained in the product manual.
- In the event the product is damaged by a third party.
- In the event the product is damaged due to Acts of God (including fire, flood, earthquake, storm, hurricane or other natural disaster).
- In the event the surface of the product is damaged by use.

Warranty Service

To obtain product warranty service, send the defective product, at your expense, to the manufacturer or the seller along with proof of purchase (a receipt that shows the purchase date, a product registration certificate of the Website, and other relevant information). Take necessary measures to protect the product. In order to get a refund or replacement, you must include the whole package as it was purchased.

Free-of-charge Service

Sena will provide free-of-charge repair or replacement service for the product when product defects occur within the scope of the product warranty during the warranty period.

