





# Contents

1. Important safety instructions.....	2
2. Device functions.....	7
3. Device.....	8
4. Remote controller.....	9
4.1. Inserting battery.....	9
4.2. Description of buttons.....	9
5. Control.....	11
5.1. Installation.....	11
5.2. Turning on and off.....	11
5.3. Setting the time.....	11
5.4. Sleep Timer function.....	11
5.5. Tuning FM radio.....	12
5.6. Turntable and recording.....	13
5.7. Connector AUX IN and recording.....	14
5.8. Playback of MP3/WMA songs using USB memory medium or memory card.....	15
5.9. Removal of USB device/Memory card.....	16
5.10. Removal of file from USB device/SD card.....	16
5.11. Headphones jack and line output jack.....	16
5.12. BLUETOOTH connection.....	16
6. Technical specifications.....	17

# 1. Important safety instructions

**WARNING**

DO NOT EXPOSE THIS PRODUCT TO RAIN AND INCREASED HUMIDITY TO REDUCE THE RISK OF FIRE AND INJURY FROM ELECTRIC SHOCK.



**WARNING:** WHEN YOU REMOVE THE COVER OF THE DEVICE (OR ITS REAR PART) THERE IS A RISK OF FIRE OR ELECTRIC SHOCK. THERE ARE NO PARTS INSIDE THE DEVICE THAT COULD BE REPAIRED BY THE USER. LEAVE ALL SERVICING TO QUALIFIED SERVICE TECHNICIANS.



The lightning symbol inside an equilateral triangle warns the user that inside the devices are uninsulated conductors under “dangerous voltage” that is capable of causing electric shock to persons.



The exclamation point within an equilateral triangle alerts the user to important instructions in the supplied publication concerning operation and maintenance.

**WARNING:**

**TO USE THE PRODUCT PROPERLY, READ THE INSTRUCTIONS THOROUGHLY AND RETAIN THEM FOR FUTURE REFERENCE. IF THE DEVICE REQUIRES REPAIR OR MAINTENANCE, CONTACT AN AUTHORIZED SERVICE CENTER.**

**WARNING:**

**IF IT IS NECESSARY TO REMOVE THE COVER, FIRST UNPLUG THE POWER CORD FROM THE OUTLET.**

## 1. Read the operating manual

After unpacking the product, please read the operating instructions and observe those instructions about operation and other activities.

## 2. Power

This device can only be connected to the power corresponding to the specifications on the nameplate. If you are not sure about the parameters of your electrical outlet, contact your vendor or local power company. For products powered by batteries or other sources, obtain the necessary information in the manual.

### 3. Ventilation

Slots and openings on the cover of the device provide ventilation. They protect the unit from overheating and ensure its proper functioning. Do not cover or block these openings. Do not block ventilation openings by placing the product on a bed, sofa, rug or similar surface. The device can be placed in a library, cabinet or another confined space only if proper ventilation is ensured and the conditions specified by the manufacturer are fulfilled.

### 4. High temperatures

Do not place the device near radiators, stoves, fireplaces or other heat sources (including amplifiers). Do not place an open flame on the device, e.g. a burning candle.

### 5. Water and moisture

Do not use this product near water – e.g., near a bathtub, kitchen sink, in a wet basement, near a swimming pool etc. Do not place containers filled with water on the device (e.g. vases).

### 6. Cleaning

Pull the plug out of the outlet before cleaning. Do not use liquid or aerosol cleaners. Clean the device using wet cloth.

### 7. Protection of power cables

Place the cables so that they are not stepped on and not damaged by the objects standing above them or beside them. Pay special attention to places where the cables come out of the outlets, extension cords and the device.

### 8. Overloading

Do not overload outlets, extension cords, or integral switch connectors, so that there is no increased risk of fire or electric shock.

### 9. Thunderstorm

Before a thunderstorm or before longer periods when the unit would not be in use, remove the plug from the outlet. You will prevent damage by lightning striking power lines or high voltage.

### 10. Penetration by objects or liquids

Do not attempt to insert in the device any objects through the ventilation openings. In the event that they come into contact with any part which is energized or short circuited, there is a risk of fire and electric shock. Prevent penetration of liquid into the device.

### 11. Connection

Do not use the connection methods not recommended by the manufacturer, since they could cause a threat to health and property. The outlet where you insert the power cable or adapter must be easily accessible.

## 12. Accessories

Do not place the device on unstable carts, stands, tripods, shelves or small tables. In case of fall it may cause an injury to a child or an adult and damage to the device. Use only carts, stands, tripods and tables recommended by the manufacturer or supplied as accessories with the product. When attaching the device, use only original accessories and follow the manufacturer's instructions. Move cautiously with the device placed on a cart. A quick stop, an exertion of excessive force or movement on an uneven surface may cause the overturning of the cart.

## 13. Load

Do not step on the device and do not place heavy objects on it. Should such an object fall, it could cause injury and damage to the device.

## 14. Connection

When connecting the device to other devices, turn off all the devices and disconnect them from power. Before connecting, carefully read the instructions of connected device and follow the provided instructions.

## 15. Volume

Set the volume to minimum before turning on the device. You could damage your hearing or the speakers if the volume is too high.

## 16. Sound distortion

Do not let the device play distorted sound for a longer period of time. This could cause overheating of speakers and subsequent fire.

## 17. Headphones

When using headphones, use reasonable volume level. Prolonged listening to excessive volume may damage hearing.

## 18. Records

Do not use cracked, warped or repaired records. They could fall apart and cause serious injury or damage.

## 19. Damage requiring repair

If one of the following situations happen, unplug the unit and refer servicing to qualified service personnel:

- a) the power cable or the plug are damaged;
- b) some object fell or liquid leaked into the device;
- c) the device was exposed to rain or water;
- d) while operating it according to the instructions, the device does not work normally. Adjust only the settings, which are listed in the operating manual. Any other setting may seriously damage the device. To return the device into operation may then require extensive servicing;
- e) the device fell or was damaged in any way;

- f) If there are significant changes in the functioning of the device – in such a case it is necessary to seek out help of a qualified service centre.

## 20. Repairs

Do not attempt to repair the device yourself. Opening the cover may expose you to injury from electric shock and other dangers. Leave all servicing to qualified technicians.

## 21. Spare parts

If you need to replace any parts, make sure that the service technician uses either original parts, or those matching the originals in all parameters. Using unsuitable parts can cause, among other things, risk of fire and injury from electric shock.

## 22. Safety check

Upon completion of any service, ask technician to check that the device is working properly.

## 23. Remote control and batteries

- Do not expose the remote control and batteries to direct sunlight or heat sources, such as radiators, heat exchangers, ovens or other appliances (including amplifiers) producing heat. Do not use and do not leave the device near an open fire.
- Make sure the sensor is not exposed to intense light (e.g. sunlight) or fluorescent tube light, which could lower the efficiency and reliability of the remote controller.
- The remote controller or battery must not be exposed to dripping or running water and objects filled with liquid, e.g. vases, shall not be placed on the device. Protect the remote controller against becoming wet, sprayed or poured on by any liquid. Do not use outdoors. Failure to respect these instructions can lead to the remote controller or battery becoming damaged.
- Do not use the device close to water.
- It is necessary to consider the environmental impact when liquidating the batteries.
- Incorrect use of batteries can cause electrolyte leakage and corrosion. Follow the following instructions to ensure proper remote control operation:
  - Do not insert the batteries in the wrong direction.
  - Do not charge, heat, open or short the batteries.
  - Do not throw batteries into a fire.
  - Do not leave dead batteries in the remote controller.
  - Do not combine various types of batteries or old and new batteries.
  - If you do not use the remote controller for a longer period of time, remove the batteries to prevent damaging the remote controller by the batteries leaking out.
  - If the remote control does not work properly or its effective range decreases, change all the batteries for new ones.

- If there is an electrolyte leakage from the batteries, have the remote control serviced by an authorized technician.

**WARNING:**

**TO PREVENT RISK OF FIRE OR ELECTRIC SHOCK, DO NOT EXPOSE THE DEVICE TO RAIN OR MOISTURE.**

**WARNING:**

**THE BATTERIES MUST NOT BE EXPOSED TO EXCESSIVE HEAT, FOR EXAMPLE SUNLIGHT, FIRE, ETC.**

**Due to the wide range of SD/MMC/MS cards/USB devices available on the market, we cannot guarantee compatibility with all types of SD/MMC/MS cards/USB devices.**

## 2. Device functions

- Turntable with selectable speeds 33/45/78 rev./min.
- Turntable with automatic/manual stop
- Belt-driven system
- Direct recording to USB /SD card from the record player, FM radio and AUX IN input
- AUX IN input for connecting other devices (e.g. CD and MP3 players)
- Port USB / slot SD for playing MP3
- PLL radio with presets of FM stations
- Clock/Sleep functions
- LCD display with blue backlight
- Line output RCA
- Built-in stereo speakers
- Connection to the computer function: recording from the record player in the computer
- Includes centre adapter 45 rev/min., remote control and external power adapter
- Bluetooth receiver

### 3. Device

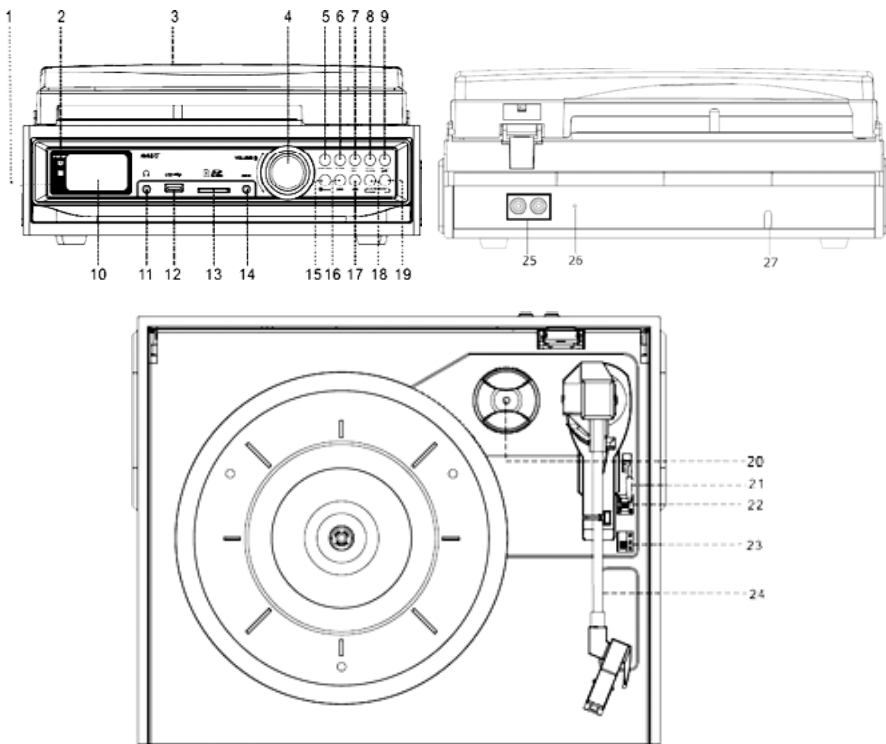

- |                                   |   |
|-----------------------------------|---|
| 1) Remote control sensor          | 16) Play/Pause button ►   (T-SCAN)              |
| 2) Standby mode indicator         | 17) Stop button ■                               |
| 3) Dust cover                     | 18) Skip back button ◀◀                         |
| 4) Volume control/switch          | 19) Skip forward button ▶▶                      |
| 5) Function – switching sources   | 20) Removable centre adapter<br>45 rev./min.    |
| 6) Sleep – falling asleep         | 21) Lifting lever (to play/pause the<br>record) |
| 7) Rec / del – recording, erasing | 22) On/off button for automatic stop            |
| 8) Album / preset down            | 23) Speed selector 33/45/78 rev./min.           |
| 9) Album / preset up              | 24) Tone arm                                    |
| 10) LCD display                   | 25) Line output jack                            |
| 11) Headphones jack               | 26) FM Antenna (fixed)                          |
| 12) USB port                      | 27) Power adapter jack                          |
| 13) Slot for SD/MMC cards         |   |
| 14) AUX IN input connector        |   |
| 15) Mode / clock – mode, clock    |   |

## 4. Remote controller

### 4.1. Inserting battery

Infrared transmitter requires one piece of CR2025 lithium battery to operate. Insert it as shown on the underside of the remote control.

### 4.2. Description of buttons



- 1) **Standby:** switching between standby and operating mode.
- 2) **Preset/Album DN:** performs the same function as “album down / preset down” (8) on the device.
- 3) **Preset/Album UP:** performs the same function as “album up / preset up” (9) on the device.
- 4) **TIMER / SLEEP:** perform same function as “SLEEP / TIMER” button on the unit.
- 5) **Mute:** muting and restoring sound.
- 6) **SNOOZE:** snooze function for alarm.
- 7) **Rec/Del:** performs the same function as “rec/del” (7) on the device.
- 8) **Fm st.:** choice between stereo and mono reception of FM radio.
- 9) **Funcnt:** performs the same function as “function” (5) on the device.
- 10) **Mode/clock:** performs the same function as “mode/clock” (15) on the device.
- 11) **▶|| (play/pause):** preforms the same function as “▶|| play/pause” (16) on the device.
- 12) **■ (stop)/band:** performs the same function as “■ (stop)/band” (17) on the device.
- 13) **◀◀ (skip down):** performs the same function as “◀◀ skip back (18)” on the device. In addition, it can be used to search for radio frequencies in the tuning mode.

- 14) **▶▶I (skip up)**: performs the same function as “**▶▶I skip forward** (19)” on the device. In addition, it can be used to search for radio frequencies in the tuning mode.
- 15) **Volume +/-**: volume level control. To set press repeatedly.

## 5. Control

### 5.1. Installation

- Unpack all parts and remove protective material.
- Before connecting the device to the power supply, check the voltage and all other connections.
- Do not block air vents and make sure that there is several centimetres space around the unit to ensure ventilation.

### 5.2. Turning on and off

1. Connect **the external power adapter** to the **connector of the external power adapter**.
2. Press **the switch** (4) to turn the device on, **indicator of standby mode** (2) turns off. Once the LCD backlight is lit and on it one of the operating modes, it means that the power supply is normal and the system is ready for use.

### 5.3. Setting the time

1. When **the standby mode indicator** (2) is lit, the device is in a standby mode.
2. Choose in the standby mode between 12- and 24 hour mode: press **mode** (15), 12h/24h will flash on the display. Press **skip forward** (19) or **skip back** (18) to select 12 hour or 24 hour mode. Confirm by pressing again the **mode** (15) button.
3. Setting the hour: Using buttons **skip forward** (19) or **skip back** (18) select the correct hour and confirm by pressing **mode** (15).
4. Setting the minute: after finishing 3rd step, using buttons **skip forward** (19) or **skip back** (18) select the correct minute and confirm by pressing **mode** (15).
5. Time setting is complete and the seconds colon starts to indicate the passage of time.

### 5.4. Sleep Timer function

1. When the device is in operating mode, press repeatedly the **Sleep** (6) button to select the time until switching to standby mode in minutes (in descending order 90 > 80 > 70 ... > 10 off (timer)).
2. Setting the time of transition to sleep mode is saved when the display shows the icon "SLEEP".
3. When the specified period ends, the device automatically switches to standby mode.
4. When you press **sleep** (6) once when the icon "sleep" shows on the display, you can find out how many minutes are left before entering the standby mode. Or, by repeatedly pressing the button **SLEEP** (6) you can change the sleep time until the timer is cancelled (OFF).

## 5.5. Tuning FM radio

1. Press **function** (5) to select radio mode.
2. To find a station press and hold **skip forward** (19) or **skip back** (18) for period of 1–2 seconds and then releasing it.
3. The device will automatically search in the radio bandwidth, and stops after finding a station.

### 5.5.1. Automatic saving of the preset FM radio stations (Tuner Scan, T-SCAN)

1. Press **play/pause** ►|| (16) in the radio mode, the device starts automatic search of radio frequencies. After finding a clear signal, it saves automatically the radio station starting with channel "P-01".
2. The number of stations that can be tuned and saved depends on the reception in different regions and countries.
3. After automatic tuning select the required station by pressing **preset down** (8) or **preset up** (9) button.

### 5.5.2. Manual preset saving of FM radio stations

1. After finding the required frequency in the radio mode press the **mode** (15) button. The respective frequency will be saved in the device.
2. Select the required station by pressing **preset down** (8) or **preset up** (9).

**Note:**

Maximum number of memory devices: 30 stations for FM band.

### 5.5.3. Mono or stereo reception of FM (only remote control)

- Press "fm st." on the remote control to select either FM mono or FM stereo mode. If the stereo signal is weak, it is preferable to receive the program as mono.
- The icon "st" on the display indicates that the reception taking place is in the FM stereo mode.

#### Tips for better reception

1. FM: the receiver has a built-in FM antenna that hangs in the rear. This antenna should be fully unfolded for ensuring the best possible reception.

### 5.5.4. Radio recording, FM stereo

1. Press **function** (5) to select radio mode.
2. Insert memory device (USB unit, SD or MMC card).
3. Press **rec** (7) and the icon USB or SD starts flashing on the display.
4. The system starts recording after a few seconds.
5. The "rec" will appear on the display during recording.
6. If you want to stop recording, press **stop** ■ (17) and "rec" disappears.

7. Listening to newly recorded track:
  - Press **function** (5) to select USB or SD mode.
  - Press **skip forward** (19) or **skip back** (18) to select the newly recorded track.
  - A newly recorded track is on a USB drive / memory card always saved as last.

**Note:**

- Recording speed is 1:1 according to actual playing time of the FM radio
- Recording format is preset to mp3 with a transfer rate: 128 kbps
- The FM stereo frequency is fixed during recording and tuning cannot be performed.

## 5.6. Turntable and recording

**Note:**

- Remove the cover of the stylus.
- Before operation, make sure that the tone arm is disengaged from the support, and then attach it again.

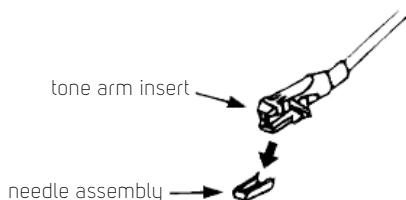

1. Press **function** (5) to select the item “phon” on the display.
2. Set **speed selector** (23) in correct position according to the played record.
3. Place the record on the platter; when needed use the 45 rev./min. adapter.
4. By moving the **lifting lever** (21) up, raise the tone arm from the park position and then move it slowly over the record. The platter starts turning.
5. Push the **lifting lever** (21) toward yourself to let the tone arm down and to gently touch the record. The record starts now playing.
6. By moving the **lifting lever** (21) up, raise the tone arm up from park position. The record will continue turning, but the playback stops. If you want to continue to play, you have to push down the **lifting lever** (21).
7. Adjust the volume to required level.
8. At the end of the record, the platter stops turning automatically. By moving the **lifting lever** (21) up raise the tone arm and move it into park position, then push down the **lifting lever** (21).
9. If you want to stop the playback manually, lift the tone arm from the record and return it to the park position.

**Note:**

If some records have the final groove molded out of reach for automatic stop of this unit, the playback will stop before end of the last song. In this event turn **the switch of the automatic stop** (22) in the "off" position (off). The record will play to the end, but does not stop automatically (to stop the platter from turning, turn the device off using **switch** (4) or put the **automatic stop switch** (22) back to the "on" position (on). Then return the tone arm in the park position.

### 5.6.1. Recording from the record player

1. Press **function** (5) to select the item "phon" on the display.
2. Insert memory device (USB unit, SD or MMC card).
3. Press **rec** (7) and the icon USB or SD starts flashing on the display.
4. Press **skip forward** (19) or **skip back** (18) to select the required mode (USB or SD) for recording. Then confirm by pressing the **rec** (7) button again. After a few seconds the system starts recording mode.
5. The "rec" will appear on the display during recording.
6. End recording:
  - Press **stop** ■ (17), the "rec" disappears, the recording stops.
7. Listening to newly recorded track:
  - Press **function** (5) to select USB or SD mode.
  - Press **skip forward** (19) or **skip back** (18) to select the newly recorded track.
  - A newly recorded track is on a USB drive / memory card always saved as last.

**Note:**

- Recording speed is 1:1 according to real time playback of the turntable.
- Recording format is preset to mp3 with a transfer rate: 128 kbps

### 5.7. Connector AUX IN and recording

Press **function** (5) to select the item "aux" on the display and connect the external audio device (e.g. CD player) using input **AUX IN**. Audio signals from an external audio device can be played using the system.

#### 5.7.1. Recording from the AUX IN input

1. Press **function** (5) to select AUX mode.
2. Insert memory device (USB unit, SD or MMC card).
3. Press **rec** (7) and the icon USB or SD starts flashing on the display.
4. The system starts recording after a few seconds.
5. The "rec" will appear on the display during recording.
6. If you want to stop recording, press **stop** ■ (17) and the "rec" disappears.
7. Listening to newly recorded track:

- Press **function** (5) to select USB or SD mode.
- Press **skip forward** (19) or **skip back** (18) to select newly coded track.
- Newly coded track is in the USB/Memory card always saved as last.

**Note:**

- Recording speed is 1:1, according to the real time playback of an external audio device.
- Recording format is preset to mp3 with a transfer rate: 128 kbps

## 5.8. Playback of MP3/WMA songs using USB memory medium or memory card

### 5.8.1. Connection

The system allows playback of MP3 / WMA files that are stored on the storage media connected to the USB port or SD / MMC memory card.

1. Insert the USB memory correctly and make sure it is fully inserted, or insert the memory card with the contacts down and back (approximately to half of its length). Insert directly without bending. Do not use excessive force.
2. Reverse or opposite connecting of the USB/card may damage the audio system or the memory storage media (USB flash drive/SD/ MMC card). Make sure of the correct orientation before connecting.
3. Press **function** (5) to select item “usb” or “card” on the display and insert the memory device (USB unit, SD or MMC card).
4. After selecting the function, the system starts to read automatically the memory medium and the display shows the total number of MP3/WMA files (e.g. 016).
5. Then the system automatically starts playing the audio from the desired device (USB or SD / MMC).

#### Play/pause ►|| (16) button

- Press **play/pause ►||** (16) once to pause playback; press again to resume it.

#### Stop ■ (17) button

- Press **stop ■** (17) to end sound playback. The display shows the total number of MP3/WMA files. Then you can use **skip forward** (19) or **skip back** (18) to select skipping by a file forward or backward.

#### Skip forward (19) or skip back (18) buttons

- During playback of MP3/WMA files press once **skip forward** (19) to play the next file. Press and hold **skip forward** (19) button to speed up selection in the forward direction.
- During playback of MP3/WMA files press once **skip back** (18) to play the previous file. Press and hold **skip back** (18) to speed up selection in the backwards direction.

#### Folder search

Press **album down** or **album up** to select previous or next folder.

### Repeat function

During audio playback press once **mode** (15), all songs on the entire USB, SD or MMC card will be repeatedly replayed. When you press **mode** (15) again, one song will be repeated.

#### Note:

- If you connect the system to an MP3 player via the USB port, due to differences in format of MP3 encoding the playback may not be possible from some MP3 players connected to the USB port. This is not a malfunction of the system.
- There are a large number of manufacturers of USB devices and SD cards. Their production and format differ. Therefore we cannot guarantee that this device will support all USB devices and SD cards of all brands.
- Supported are SD card of capacity up to 8 GB.

## 5.9. Removal of USB device/Memory card

If you want to remove USB device/ memory card, turn off the power or switch the unit to another mode (record player, cassette player, AUX or radio) and then remove the USB device / SD card by pulling it out of the slot in a straight line.

## 5.10. Removal of file from USB device/SD card

The system allows you to delete a file stored on a USB drive or SD card.

1. Press and hold **del** (7) for 3–5 seconds during playback of the required song.
2. The display shows message "del".
3. Message "del" disappears from the display, which means that the song is deleted.

## 5.11. Headphones jack and line output jack

- This system can be connected to headphones or an external amplifier / speaker using **3,5mm headphones jack**.
- This system can be connected to an external device (e.g. an amplifier or a speaker) using **line output jack** on the back.

## 5.12. BLUETOOTH connection

This unit has Bluetooth receiver to play music from your BT device (mobile phone). Select BT source by repeated push of Function key. Switch ON Bluetooth on your phone and select "STT 212U" for pairing. Once paired successfully a speaker sound confirms it.

### Saving energy

If the turntable / USB device/ SD card / AUX IN does not for 10 minutes produce any sound signal, it automatically switches to standby mode to save power.

## 6. Technical specifications

Speed selection: 33/45/78 rev./min.

Auto stop function

PLL digital FM tuner (30 presets for FM band)

Slot for USB / SD card

Direct recording to USB / SD from LPs, radio or an external source

MP3 compatible

Line output (cinch L/R)

Integrated stereo speakers (2× 5 W)

Power consumption: 8W

Standby power consumption: <0,5W

Automatic standby time: 10min (in case of no playback source)

Dimensions: 305 × 288 × 124 mm

Weight: 1.9 kg

Accessories: remote control, operating manual

This device has a power saving function that automatically turns off or switch to standby if no button is pressed for a certain period of time under certain operating conditions. If this function is disabled, power consumption will increase.

### Power adapter specifications

Manufacturer's name or trademark, trade registration number and address:	DongGuan Obelieve Electronic Co.,Ltd
Model identification number	OBL-1201000E
Input voltage	100–240V
Input frequency	50/60 Hz
Output voltage	12 V
Output current	1 A
Output power	12 W
Average efficiency in active mode	≥87,4%
Efficiency in low active mode	(10%) 79%
Power consumption in stand-by mode	0.3W

The above data may change without prior notice.

The original version is in Czech.

Manufacturer address: FAST ČR, a.s., U Sanitasu 1621, 251 01 Říčany  
info@sencor.com

## INSTRUCTIONS AND INFORMATION REGARDING THE DISPOSAL OF USED PACKAGING MATERIALS

Dispose of packaging material at a public waste disposal site.



### DISPOSAL OF USED ELECTRICAL AND ELECTRONIC APPLIANCES

The meaning of the symbol on the product, its accessory or packaging indicates that this product shall not be treated as household waste. Please, dispose of this product at your applicable collection point for the recycling of electrical & electronic equipment waste. Alternatively in some states of the European Union or other European states you may return your products to your local retailer when buying an equivalent new product.

The correct disposal of this product will help save valuable natural resources and help in preventing the potential negative impact on the environment and human health, which could be caused as a result of improper liquidation of waste. Please ask your local authorities or the nearest waste collection centre for further details. The improper disposal of this type of waste may fall subject to national regulations for fines.

#### For business entities in the European Union

If you wish to dispose of an electrical or electronic device, request the necessary information from your seller or supplier.

#### Disposal in other countries outside the European Union

If you wish to dispose of this product, request the necessary information about the correct disposal method from local government departments or from your seller.



The product meets EU requirements.

Hereby, FAST ČR a.s. declares that the radio equipment type STT 212U is in compliance with Directive 2014/53/EU. The full text of the EU declaration of conformity is available at the following internet address: [www.sencor.eu](http://www.sencor.eu).

Changes to the text, design and technical specifications may occur without prior notice and we reserve the right to make these changes.

The original version is in Czech.

Manufacturer: Fast ČR, a.s., U Sanitasu 1621, CZ 251 01 Říčany, Czech Republic, [info@sencor.com](mailto:info@sencor.com)

# SENCOR<sup>®</sup>

## EN Warranty conditions

**Warranty card is not a part of the device packaging.**

This product is warranted for the period of 24 months from the date of purchase to the end-user. Warranty is limited to the following conditions. Warranty is referred only to the customer goods using for common domestic use. The claim for service can be applied either at dealer's shop where the product was bought, or at below mentioned authorized service shops. The end-user is obligated to set up a claim immediately when the defects appeared but only till the end of warranty period. The end user is obligated to cooperate to certify the claiming defects. Only completed and clean (according to hygienic standards) product will be accepted. In case of eligible warranty claim the warranty period will be prolonged by the period from the date of claim application till the date of taking over the product by end-user, or the date the end-user is obligated to take it over. To obtain the service under this warranty, end-user is obligated to certify his claim with duly completed following documents: receipt, certificate of warranty, certificate of installation.

### **This warranty is void especially if apply as follows:**

- Defects which were put on sale.
- Wear-out or damage caused by common use.
- The product was damaged by unprofessional or wrong installation, used in contrary to the applicable instruction manual, used in contrary to legal enactment and common process of use or used for another purpose which has been designed for.
- The product was damaged by uncared-for or insufficient maintenance.
- The product was damaged by dirt, accident of force majeure (natural disaster, fire, and flood).
- Defects on functionality caused by low duality of signal, electromagnetic field interference etc.
- The product was mechanically damaged (e.g. broken button, fall).
- Damage caused by use of unsuitable media, fillings, expendable supplies (batteries) or by unsuitable working conditions (e.g. high temperatures, high humidity, quakes).
- Repair, modification or other failure action to the product by unauthorized person.
- End-user did not prove enough his right to claim (time and place of purchase).
- Data on presented documents differs from data on products.
- Cases when the claiming product cannot be indentified according to the presented documents (e.g. the serial number or the warranty seal has been damaged).

### **Manufacturer:**

FAST ČR, a.s., U Sanitasu 1621, Říčany 251 01, Czech Republic  
info@sencor.com

### **Authorized service centers:**

Visit [www.sencor.com](http://www.sencor.com) for detailed information about authorized service centers.

The original version of the instructions is in the Czech language, other language versions are made by the appropriate translation.

