

2.4G

14+

DRONE INSTRUCTION MANUAL

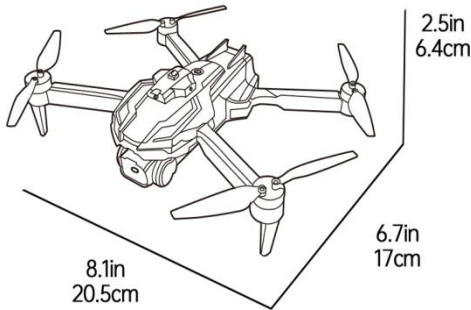
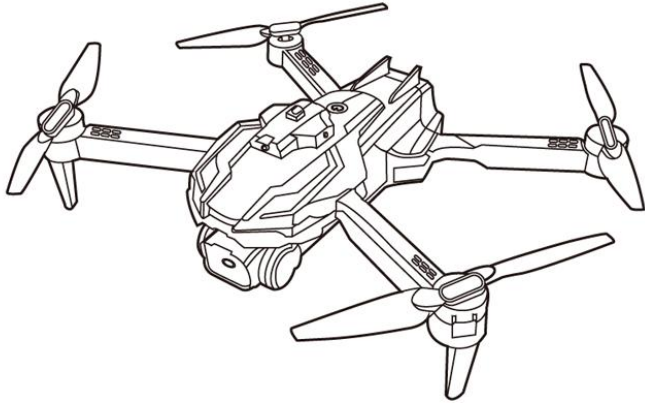

The pictures are for reference only, subject to the actual product.

NAMES OF CONTROLLER

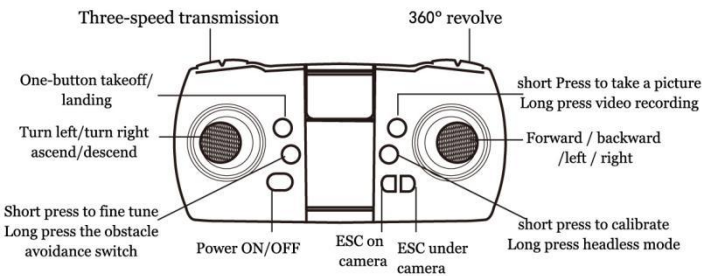
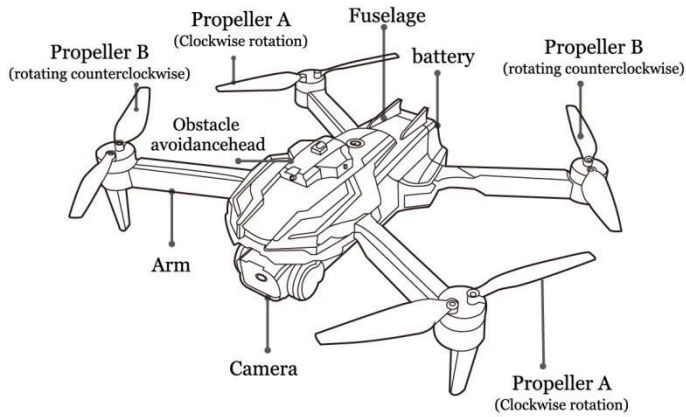

READY TO FLY

1. Unfold the quadcopter and place it on a horizontal position, then open up the power switch on the quadcopter. When the indicator lights flash. It means that the quadcopter goes into the flight standby mode



Note: The tail of the quadcopter is aimed at the controller

IMPORTANT NOTICE

1. When flying outdoors, the speed must be adjusted to the highest gear. It is not recommended to fly when the wind is too strong.

The remote control distance will be affected by the environment. Novices are not recommended to fly too high. It is recommended to practice flying at an altitude of 5-10 meters first.

2. Replace the A/B number of the original fan blade and distinguish the AB number (refer to page -3)

3. The remote control works with alkaline batteries.

4. Quadcopter is not a toy. There is still some risks exist. Please be sure to correctly use strictly in accordance with the safety notes and instructions. Any modification or improper use of the product may cause unexpected danger or accident. Please do not overlook.

5. This product is suitable for use by people over the age of 14. Please ensure that it is operated in a safe environment. The company is not responsible for improper assembly by the user, unsafe environment, unauthorized modification, disassembly and other illegal operations.

6. This RC drone requires high flying skills. Any damages caused by wrong operations of disassemble and usage can not be replaced returned and exchanged under the warranty.

7. When flying, be sure to stay away from crowds and obstacles, and operate within a safe distance (above 4 meters). Improper assembly, damaged parts, or improper operation may cause loss of control and cause unpredictable damage and accidents.

Controllers are requested to pay attention to safe flight and understand the flight requirements and precautions in detail.



B6-P VIDEO TUTORIAL

2. Place the drone on a level surface. Turn on the remote control power switch a beeping sound is emitted, and the lights of the quadcopter are always on, indicating that the frequency alignment is successful.



电源开关 短按此按键校准

3. Short press this button to calibrate, at this time the drone lights flashes quickly and turns solid in 2-3 seconds, indicates that the gyro calibration is successful.

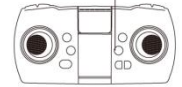

4. The gyroscope is calibrated, the motor is unlocked, the left joystick of the remote control is pushed up to the top, and then the joystick is released. At this time, the propellers of the quadcopter begin to rotate. After the unlocking is successful, you can push the left joystick or press one button to raise the aircraft for flight operation.



INSTRUCTIONS FOR ALTITUDE-HOLD CONTROL

STARTING THE QUADCOPTER

One-key take-off: After the quadcopter is frequency-bound, press the one-key take-off function button on the remote control, and the quadcopter will unlock and automatically take off, rise to a certain height, and hover.



ONE KEY LANDING

When the quadcopter is flying at high altitude, press the one-key landing function button once, and the quadcopter will slowly land. During the descent, you can control the quadcopter through the steering stick and right joystick. After landing at the designated point, the propellers will stop rotating.

OPERATING INSTRUCTIONS



Push the left joystick upward and the aircraft will rise. Pull the left joystick down and the aircraft descends.



Push the right joystick upward to make the quadcopter move forward; Pull the right joystick down and the quadcopter moves backwards.



Push the left joystick to the left and the aircraft will rotate to the left; push the left joystick to the right and the aircraft will rotate to the right. (This mode is recommended to be used in headless mode, otherwise it is easy to make operational errors)

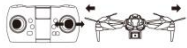

Push the right joystick to the left, and the aircraft will deflect to the left; push the right joystick to the right, and the aircraft will deflect to the right.

FINE—TUNING OPERATION

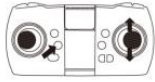

Short press the fine-tuning button, and then push the left joystick forward and backward to adjust and correct.

If the quadcopter is tilted forward/backward, fine-tune it backward/forward.

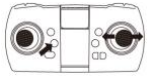

Short press the fine-tuning button, and then push the left joystick left or right to adjust and correct. If the quadcopter is deflected left/right, fine-tune it right/left.

HEADLESS MODE INSTRUCTIONS

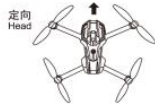
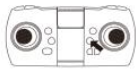

Headless mode operation:

After the quadcopter takes off, Long press the headless mode button. The lights of the quadcopter will flash and the remote controller will make a beep sound. It will enter the headless mode. The forward direction of the quadcopter no longer depends on the direction of its head. Suitable for novices. Press the headless mode button again to exit headless mode.

THREE-SPEED TRANSMISSION

During the flight of the quadcopter, press the Three-speed transmission button to switch forward, backward, left, and right flight speeds. The quadcopter speed defaults to a low speed. Press this button once to switch to medium speed. At the same time the remote control beeps "DIDI" twice.. Press the button again to switch to high speed. At the same time, the remote control beeps "DIDIDI" three times. One more pressing turn back to low speed and beep once.

360° REVOLVE

360° revolve instructions : When you are familiar with basic operation, you can do some awesome & exciting tricks and stunts! Press the 3D revolve button once to enter the tumble mode. The remote controller will make a beep sound. Push the right joystick and the quadcopter will roll in the direction of push. At the same time, the sound will disappear and it will enter the normal mode.

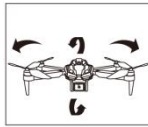

COMMON PROBLEM PROBIL EM AND SOL UTION INSTRUCTION

The problem	Reason	Counter measures
The indication light of the quadcopter is flashing and without reaction when operated	1. The quadcopter and the remote controller are not successfully linked. 2. Quadcopter is low on battery	1. Refer to (Pre-Flight Preparation) for reconnection frequency 2. Recharge the battery.
The quadcopter's blades rotate but it cannot fly	1. Insufficient battery power 2. The blades distorted	1. Recharge the battery 2. Replace the blades
The quadcopter shakes hardly	The blades distorted	Replace the blades
The fine tuning button are all on but the quadcopter still couldn't keep balance	1. The blades distorted 2. The motor doesn't work property	1. Replace the blades 2. Replace the motor
The quadcopter becomes out of control after crashing	The four-axis acceleration sensor lost its balance after crashing	Leave the aircraft for 5-10 seconds and then Press the calibration button again before taking off.

QUADCOPTER RECHARGE

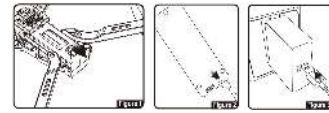

1. Press the battery and pull out, the battery can be taken out from the quadcopter (as shown in figure 1)
2. Connect with the special charging line to charge (as shown in figure 2)
3. Insert the power adapter (as shown in figure 3)

As shown in the picture above, after connecting the battery and USB charging cable, connect the USB charging cable to the power adapter for charging (you need to bring your own USB adapter). The red light of the battery pack is always on when charging and goes off when charging is completed. Charging time is about 3-4 hours.

INSTALL THE BATTERY

1. Install 3 "AA" alkaline batteries correctly according to the polarity mark of the battery box. (Batteries need to be prepared by yourself)
2. Install the battery cover and tighten the battery cover screws with a screwdriver. (Fig 3)

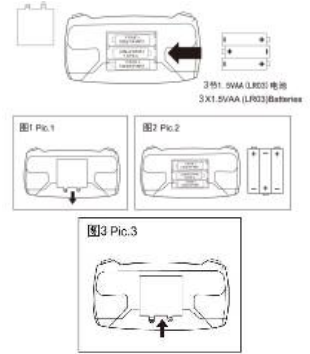

⚠ WARNING

1. Do not mix different type batteries
2. Do not mix old and new batteries
3. Install batteries with correct polarity

ONE-KEY OBSTACLE AVOIDANCE (OPTIONAL)

Long press the obstacle avoidance switch, and the quadcopter light flashes slowly at this time. When the quadcopter's flight direction encounters an obstacle, at a distance of about 1 meter, the drone is in a stopped state, and beeps "DIDI" alarm sound, and the lights are flashing faster. The drone waits for new fly instructions. (Let novices experience flying more safely)

Basic instructions for drones

1. UA level:
The B6 drone is a C0-level toy drone. This type of drone is usually designed for entertainment and leisure activities and is suitable for beginners or young flying enthusiasts. Drones in the C0 category usually have more basic flight functions and simple operating systems.
2. UA mass and maximum take-off mass (MTOM):
B6 is a lightweight remote control folding aircraft with a take-off weight of 162 grams.
3. Maximum flight speed and maximum flight altitude of UAV:
The maximum flight speed is 3 m/s and the maximum flight altitude is 50 m.
4. General characteristics of the allowed payload, including mass dimensions, interface with UA, and other possible restrictions:
The B6 drone does not have a load-carrying function. This means it cannot carry additional equipment or weight, such as cameras or other sensors. It is designed primarily for the basic flying experience.
5. Remote control of UA equipment and software control methods:
The B6 drone uses 2.4G frequency for remote control and supports operation via remote control. This control method provides flexible operation options, and users can choose to use a traditional remote control or control through an application on a smart device.
6. UA behavior description when data link is lost:
The maximum height that the B6 drone can reach above the take-off point is 50 meters. Exceeding this height may cause the drone to descend out of control, and the operator cannot control the drone during the descent, which may result in the drone being lost. This safety feature reminds users to pay attention to altitude restrictions when flying to avoid flight risks.
7. Applicable ages for drones:
This aircraft is only suitable for operation by persons over 14 years of age.
8. Operation restrictions and operational risks of drones:
To ensure flight safety, please try to avoid airports, highways, train stations, subway stations, and densely populated urban areas. Do not use the aircraft in extremely bad weather such as strong winds or thunderstorms, and fly within the visual range at night.
9. Drone operation instructions:
Please refer to the manual for details. Please use this aircraft under the guidance of the manual.

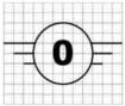

FCC Warning

This device complies with Part 15 of the FCC Rules. Operation is subject to the following two conditions:

(1) This device may not cause harmful interference, and (2) this device must accept any interference received, including interference that may cause undesired operation.

NOTE 1: This equipment has been tested and found to comply with the limits for a Class B digital device, pursuant to part 15 of the FCC Rules. These limits are designed to provide reasonable protection against harmful interference in a residential installation. This equipment generates, uses and can radiate radio frequency energy and, if not installed and used in accordance with the instructions, may cause harmful interference to radio communications. However, there is no guarantee that interference will not occur in a particular installation. If this equipment does cause harmful interference to radio or television reception, which can be determined by turning the equipment off and on, the user is encouraged to try to correct the interference by one or more of the following measures:

- Reorient or relocate the receiving antenna.
- Increase the separation between the equipment and receiver.
- Connect the equipment into an outlet on a circuit different from that to which the receiver is connected.
- Consult the dealer or an experienced radio/TV technician for help.

NOTE 2: Any changes or modifications to this unit not expressly approved by the party responsible for compliance could void the user's authority to operate the equipment.

The device has been evaluated to meet general RF exposure requirement. The device can be used in portable exposure condition without restriction.