



Manual



04-1431A

CE-H3IP01-S1- Kit
CE-H3IP11-S1- RX
HDMI Over IP Extender
with IR - 150m

User Manual

Thank you for choosing **SIIG** for your connectivity needs in IT and AV products. Our products are engineered for optimal performance and reliability. To ensure the best experience and safety, please read the instructions thoroughly and keep this user guide for future reference. For more details about our product range, visit www.siig.com

If you require technical support, email us at support@siig.com
For drivers or manuals, please visit www.siig.com/download



Important Safety Guidelines

This device has been rigorously tested and certified to meet international safety standards. However, as with all electronic equipment, it should be handled with care. To ensure your safety and to minimize the risk of damage, please follow these safety guidelines:

- Follow all provided instructions and warnings
- Ensure proper ventilation and avoid using near water
- Do not put any items into the device or attempt to modify its operation
- Do not use liquid or aerosol cleaners; avoid exposure to moisture ; Unplug the device before cleaning
- If there is any strange sound, smoke or odor, pull of the cable immediately
- Use the included power adapters only. Make sure the specification matches if using 3rd-party DC power adapters
- Shut off power and make sure environment is safe before installation

Introduction

HDMI Over IP Extender with IR - 150m extends high definition 1080p HDMI signals over Cat5e/6 cable up to 150m (492ft) with IR support. It supports a direct one-to-one connection or one-to-many over IP networks.

Key Features

- Extends HDMI audio/video signals up to 492ft (150m) over a single Cat5e/6 cable
- Supports resolutions up to 1080p@60Hz
- Support stereo audio from HDMI and extractor audio for PCM 2CH via 3.5mm jack on both TX & RX
- Direct one-to-one connection or one-to-many over a dedicated Gigabit Ethernet switch or cascading switches. Additional Receivers (part# CE-H3IP11-S1) are sold separately
- Supports IR signal extension - control a media player from a remote location with the included IR Blaster and IR Receiver cables
- Includes 2 power adapters to ensure a steady flow of power and data transmission
- Following TCP/IP standard of IEEE-T568B and supports up to 253 RXs
- Mountable metal housing design



Package Contents

Kit (CE-H3IP01-S1)

- 1x HDMI Over IP Extender with IR - 150m (TX+RX)
- 2 x Power Adapters (DC 5V/1A)
- 2 x IR Blaster and Receiver cable
- 1 x User Manual

RX (CE-H3IP11-S1)

- 1x HDMI Over IP Extender with IR - 150m - Receiver
- 1 x Power Adapters (DC 5V/1A)
- 1 x IR Receiver cable
- 1 x User Manual

Layout

Transmitter (TX)



Figure 1: Transmitter connectors

No.	Connections	Descriptions
1	DC 5V	Connects to the included power adapter
2	Power LED	On when the Transmitter is powered
3	HDMI IN	Connects to your HDMI source with an HDMI cable (cable not included)
4	IR	Connects to the IR Blaster cable
5	Audio	Stereo audio output port
6	RJ45	Connects to the RJ45 of the Receiver using a Cat5e/6 cable
7	Reset	Press 5 sec to reset the Transmitter video signal

Receiver (RX)



Figure 2: Receiver connectors

No.	Connections	Descriptions
1	IR	Connects to the IR Receiver cable
2	Audio	Stereo audio output port
3	RJ45	Connects to the RJ45 of the Transmitter using a Cat5e/6 cable
4	DC 5V	Connects to the included power adapter
5	Power LED	On when the Receiver is powered
6	HDMI OUT	Connects to your HDMI display with an HDMI cable (cable not included)

Specifications

HDMI Signal	HDMI 1.3 and HDCP 1.2 compatible
Resolution	480p@60Hz, 576p@50Hz, 720p@50/60Hz, 1080i@24/50/60Hz, 1080p@24/50/60Hz
RJ45 protocol	TCP/IP network standard Cat5e/6 cable follows the IEEE-T568B
Transmission Distance	Up to 492ft (150m) @ 1080p60Hz
IR Remote Control	Supports 20-60KHz wide frequency remote control
Operating Temperature	5° to 131° F (-15° to 55° C)
Storage Temperature	- 4° to 140° F (-20° to 60° C)
Operating Humidity	10% to 80% relative humidity
Power Adapter	5V DC / 1A
Power Consumption	TX: 4W; RX: 4W
Dimensions	2.96" (L) x 0.87" (H) x 3.04" (W) (TX & RX)
Weight	Tx: 0.26 lbs; Rx: 0.26 lbs
Color	Black
Product Material	Metal
Certifications	FCC / CE / RoHS
Country of origin	China

Hardware Installation

1. Power off all devices including your HDMI source device and HDMI display.
2. Connect your HDMI source device to the transmitter's HDMI In with an HDMI cable (**cable not included**).
3. Connect the IR blaster cable to the Transmitter's IR port. Face the eye towards your HDMI source device's IR sensor. This connection is needed only if you need to control your HDMI source from the remote location.
4. Connect a Cat5e/6 cable between the Transmitter and Receiver Cat5e/6 port.
5. Connect an HDMI display to the Receiver's HDMI Out with an HDMI cable (**cable not included**).
6. Connect the IR Receiver cable to the Receiver's IR port. This connection is needed only if you need to control your HDMI source device from the remote location.
7. Plug in the included 5V power supply into the transmitter's & Receiver' power jack, then plug both power adapters into a reliable power source.
8. Power on your HDMI source device and HDMI display. The Extender is ready for use.

Note:

- *Dedicated IGMP Gigabit Ethernet Switches are recommended for the best performance and reliability.*
- *When connecting to an existing LAN environment, it's recommended to configure a VLAN dedicated to these transmitter and receiver to avoid traffic collision with other networking devices.*

Cat Cable Wiring

We suggest both RJ45 connectors be wired indentially using T568B wiring standard for the best performance and compatibility.

Both connections must be wired identically to the T568B standard



RJ45 Plug Colour Code (T568B)	
Contact Side - Tab is on Back	
8	BROWN
7	WHITE / BROWN
6	GREEN
5	WHITE / BLUE
4	BLUE
3	WHITE / GREEN
2	ORANGE
1	WHITE / ORANGE

Note:

You may use Cat5e / Cat6 wiring, however, for best performance Cat5e or Cat6 (particularly in electrically noisy environments) is recommended. The maximum transmission distance and video quality may be compromised by cable quality, patch cables, poor termination, wall plates, cable kinks, and electrical interference. We recommend using 100% copper 23AWG (avoid CCA type) Cat cable, in one straight run (avoid/minimize patches) and avoid close proximity to electrical sources.

Application Diagram

The HDMI Over IP Extender is perfect for extending high-definition video up to 150m distances, making it ideal for various professional AV setups, including conference rooms, and home theater systems.

One to One Mode

Direct connection between the Transmitter and Receiver or through a Gigabit LAN via a dedicated gigabit switch hub.

If deployed within an existing network, create a VLAN to segregate our devices (Transmitter and Receiver) from the rest of the network devices.

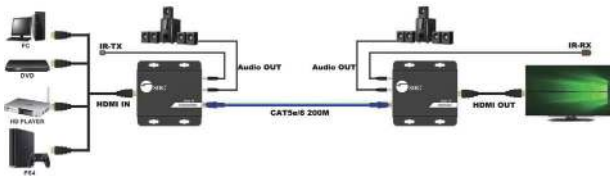

Figure 3: One to One Mode Diagram

One to Many Mode

A dedicated gigabit switch is recommended. If deployed within an existing network, create a VLAN to segregate our devices (Transmitter and Receivers) from the rest of the network devices.

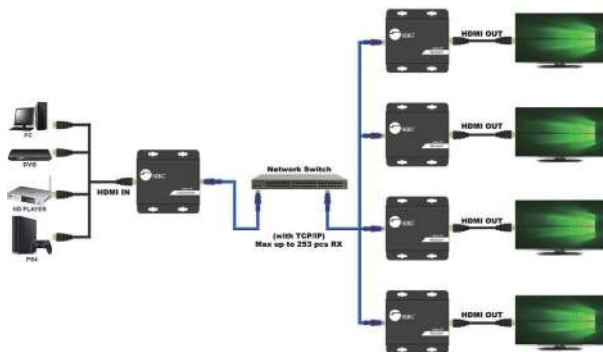

Figure 4: One to Many Mode Diagram

Notes:

- Many-to-Many connection: A smart switch is required. Create a separate VLAN for each Transmitter and its corresponding Receivers. Each VLAN can only have 1 Transmitter.
- Additional Receivers, part number is CE-H3IP11-S1 sold separately.

Application Diagram

Description:

HDMI Source Device Control from TX Location

1. Connect the IR Blaster cable to the Transmitter's IR port.
Face the eye towards your HDMI source device's IR sensor.
2. Connect the IR Receiver cable to the Receiver's IR port.

IR Pin Definition



Figure 5: IR Cable Pin Definition

FAQ & Solutions

Q: What if my display shows “Please check the TX and RX connection” on the screen?

- A: 1. Please check if the power adapters of Transmitter (TX) and Receiver (RX) are connected and powered on.
2. Check the network cable (Cat5e/6) is firmly connected between the Transmitter (TX) and Receiver (RX).

Q: When display appear the “X” on the Transmitter X left:

- A: 1. Please make sure the HDMI source device is connected to the Transmitter (TX) unit and powered on.
2. Use different HDMI cables.

Q: When display appear the “X” between Transmitter & Receiver:

- A: 1. Please check the network cable is tight for connect.
2. Reseat receiver’s power adapter again.

Q:

A: The extender is not working properly:

1. Please check the cable lengths below:
- HDMI cables: Up to 5m.
 - Network cables (Cat5e/6): Up to 150m.
2. Press the reset button 5 sec on the Transmitter for reconnect.



Disclaimer

The product name and brand name may be registered trademarks of related manufacturers. TM and ® may be omitted on the user's manual. The pictures on the user's manual are just for reference, and there may be some slight differences with the actual products. We reserve the right to make changes without prior notice to a product or system described here into improve reliability, function, or design.

SSS



Thank you for your purchase!

<https://www.siig.com>



*Please visit **SIIG Support***



*Please visit **Product page***