



POWER SPORTS

OWNER'S MANUAL

1200.4

EVO **FS**

Introduction	3
Features	3
Package contents	3
Safety instructions	4
Technologies	
DTM	5
Ultra Compact PCB	5
Robust Construction	5
Vibration Absorption Device	6
Low Battery consumption	6
Marinization with protection index IP64	6
Assembling and Disassembling the Plastic Seals	7
Panels description	
Audio inputs and controls.....	8
Power inputs and audio outputs	9
Electrical Dimensioning.....	10
Installation sequence.....	11
Wiring diagram	
Four channels wiring diagram.....	12
Three channels wiring diagram.....	12
Two channels wiring diagram.....	13
Procedure for setting the gain.....	13
Crossovers set up.....	14
Technical specs	
Parameters.....	15
Dimensional data.....	15

DEAR CUSTOMER,

CONGRATULATIONS ON ACQUIRING A PRODUCT WITH THE HIGHEST QUALITY AND TECHNOLOGY!

You have just purchased a **SoundDigital** product of the highest technology and quality, so we thank you for your confidence.

SoundDigital products are made with raw materials of the highest quality standards, and the most modern processes, equipment and technology are used in their production.

On this manual you will learn about the product, its features and characteristics, in order to obtain the best result and to be able to enjoy your music with **SoundDigital** quality and power.

To better understand and take advantage of all the functions of the product and use it safely, read this manual carefully and if you have any questions, consult our support by email info@sounddigitalusa.com.

FEATURES

- Resistant to moisture, water splash and dust;
- Compact design;
- Conformal coated circuit board;
- Variable crossover with LP / FULL / HP selector switch;
- High efficiency Class D;
- Robust construction, resistant to vibrations and bumps;
- IP64 Rating.

PACKAGE CONTENTS

- 1 EVOPS Amplifier
- 1 Installation quick guide with warranty card
- 1 Allen wrench 2mm
- 1 Allen wrench 2.5mm
- 1 Allen wrench 3mm
- 1 Soundigital promotional black sticker
- 1 Soundigital promotional white sticker

To prevent injuries to the user or damage to the amplifier, read all safety instructions written on this manual;

If you are insecure about the installation of this equipment, get in touch with our tech support or with a professional specialized in car audio/vessel audio installation;

Before proceeding with the installation of any electric equipment on your vehicle/vessel, unplug the negative (-) terminal of the battery to avoid fires, injuries or damages;

Use your sound system safely. The continuous exposure to sound pressures over 85dB may cause irreversible hearing damage;

This equipment is for use in DC voltage batteries between 12.6 and 14.4 volts. Before installing the equipment, check voltage of the batteries;

Choose a ventilated place to install the amplifier ;

Mount the amplifier in a secure way. Avoid mounting it on metallic parts of the vehicle/vessel, because it may cause ground looping (noise);

Make sure that the location chosen for the amplifier installation does not effect the operation of the vehicle/vessel;

Please select a dry location to mount your amplifier. The products are designed to operate in humid environments but the direct contact with water can damage the amplifier.

When passing cables through metallic walls, use rubber O-rings to avoid cable cutting and short-circuits.

Clean the amplifier periodically with brush or dry cloth to assure the thermal efficiency of the heatsink.

This product may reach temperatures over 60°C/140°F. Make sure it is cold before touching it;

Be careful when making holes in the vehicle/vessel. Make sure you are not making holes in the fuel tank, brake lines, boat hull or electrical cables of the vehicle/vessel;

Make sure the cables are properly secured throughout the installation;

Wear gloves, safety glasses and and all necessary PPE during the installation of SounDigital amplifiers.



Warning!

THIS "WARNING" SIGN ALERTS THE USER OF IMPORTANT INFO. NOT FOLLOWING THIS INSTRUCTIONS MAY CAUSE INJURIES TO THE USER OR DAMAGE TO THE EQUIPMENT.

DYNAMIC THERMAL MENAGEMENT - DTM

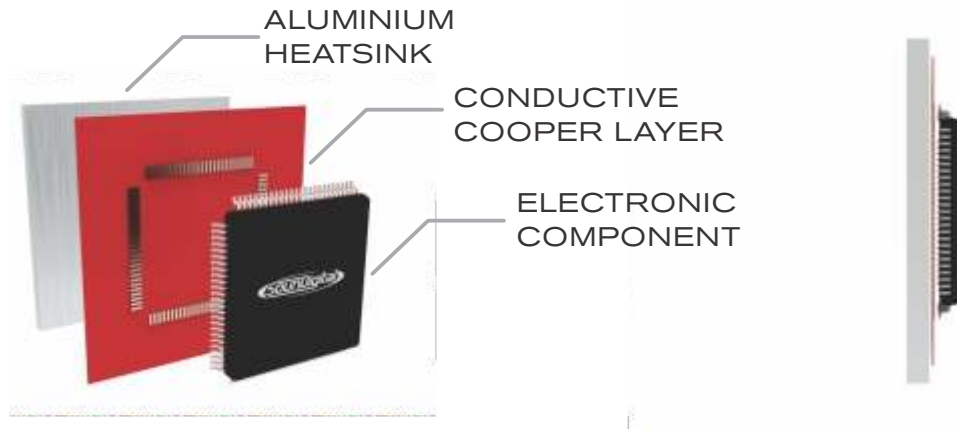

The **DTM*** is a dynamic thermal management system which always maintains a high efficiency of the amplifier by accelerating the thermal exchange of electronic components with the heatsink

** Patent. Required*

ULTRA COMPACT PCB

An intelligent layout, with great use of the PCB area and the use of modern components with reduced structure guarantee **SounDigital** products a compact design, at the same time robust and with excellent thermal efficiency.

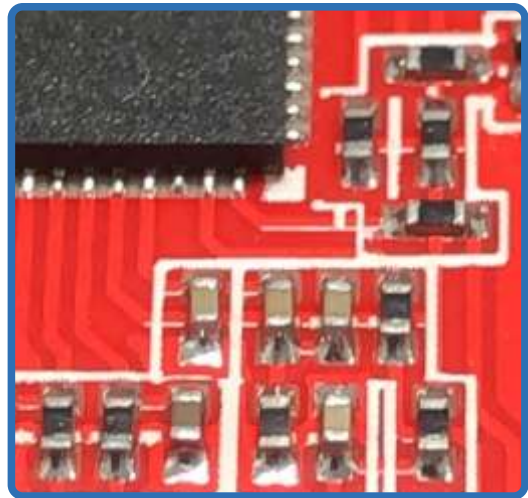

ROBUST CONSTRUCTION

Thinking about the application of power sports, the product has an extremely robust assembly, both the connection points and the layout of the plate were designed to withstand high vibrations, bumps and impacts.

VIBRATION ABSORPTION DEVICE

SoundDigital added a new device to the EVOPS products which act like shock absorbers reducing the impact of vibration on the electronic circuit board, thereby increasing the life and reliability of the amplifiers.

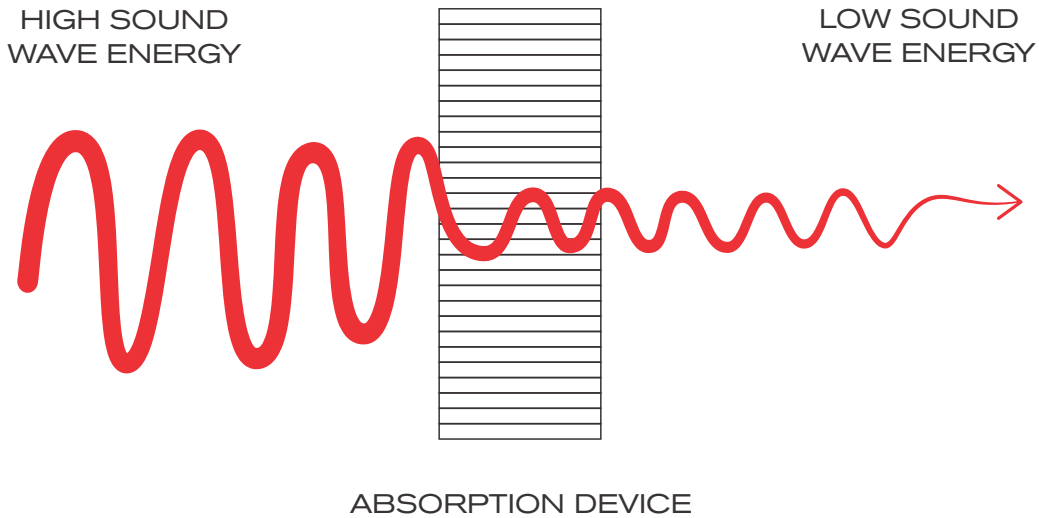

I - POWER SUPPLY

SoundDigital amplifiers are known for their low consumption of battery, and this feature was improved on the **EVOPS Line**. The new **I-POWER SUPPLY** is even more modern, which replaces the old toroidal transformers by a new generation of "E-E" core transformers delivers efficiency above 90% *,ensuring more hours of sound without battery recharge.

*Efficiency measured at power supply only

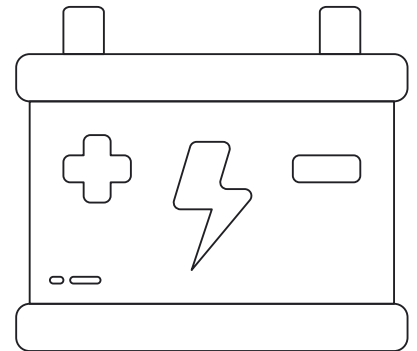

MARINIZATION WITH PROTECTION INDEX IP64

The product is protected against ingress of dust particles and water droplets from all sides, beyond that, the plate receives a conformal coating treatment to protect the components from moisture.

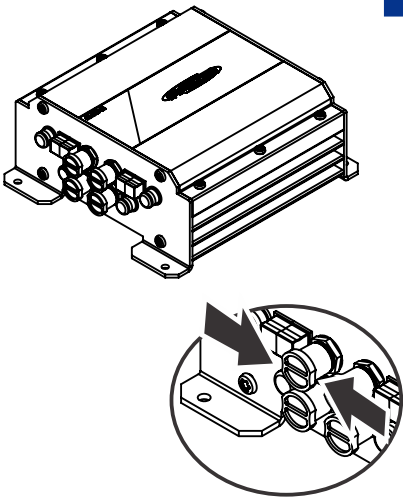
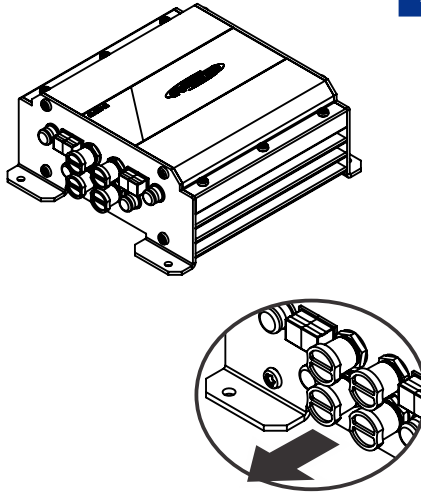
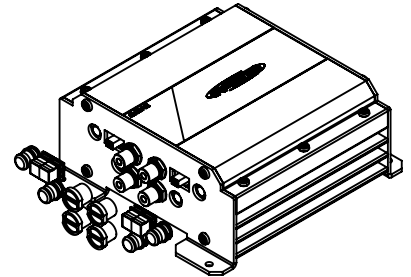
DISASSEMBLING THE PLASTICS SEALS**1****2****3**

- 1.** Squeeze the assembled Flexible Plastic Seals
- 2.** Pull out the Plastic Seals

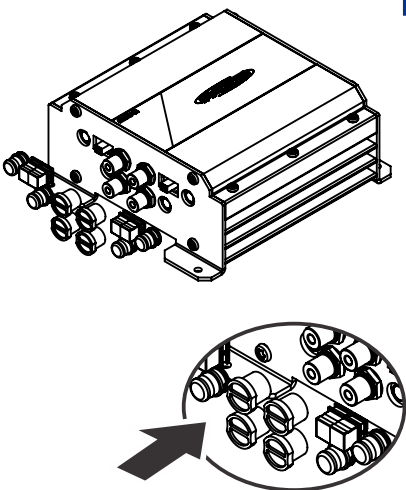
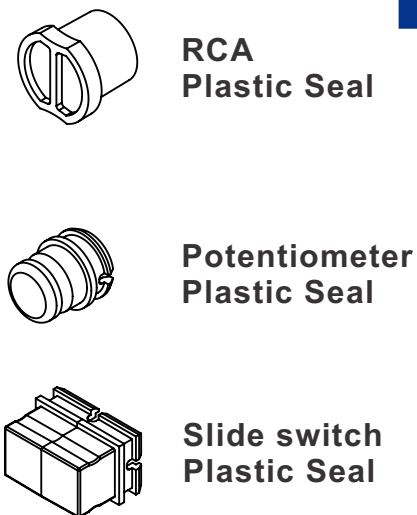
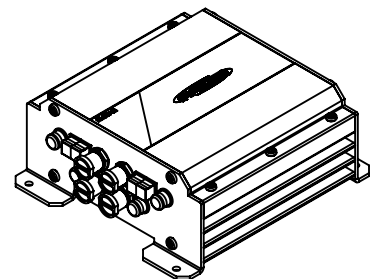
ASSEMBLING THE PLASTICS SEALS**1****2****3**

- 1.** Hold the disassembled Flexible Plastic Seals and fit them in their specific housing;
- 2.** Each connector has its specific Plastic Seal;
- 3.** Make sure the Flexible Plastic Seals are perfectly fitted.

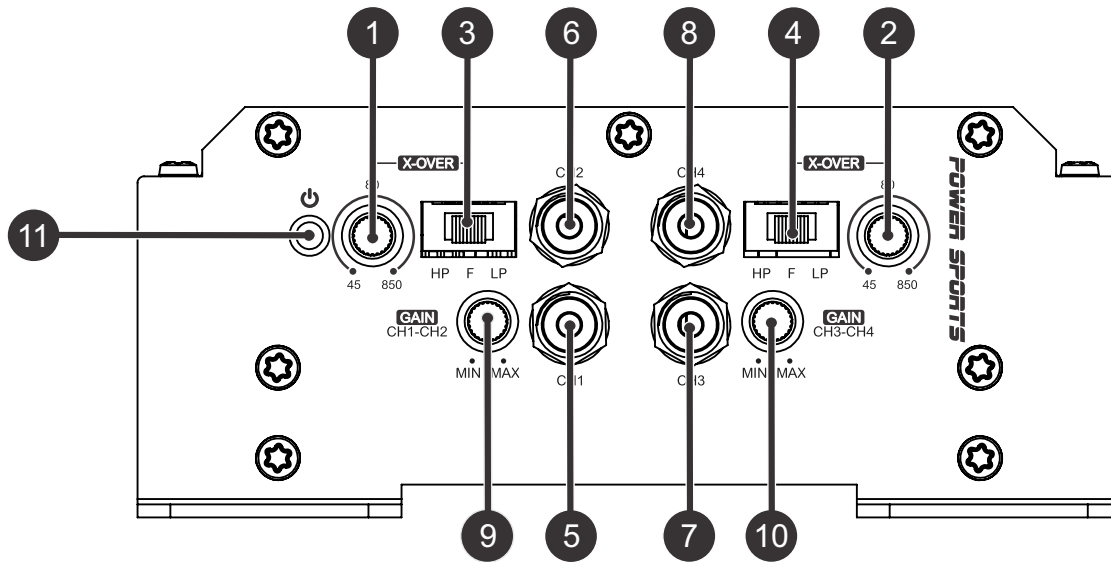

1	CH1/CH2	Variable crossover control - 45Hz to 850Hz
2	CH3/CH4	
3	CH1/CH2	Crossover Switch Low Pass - Full - High Pass
4	CH3/CH4	
5	CH1	Audio input - RCA connector
6	CH2	
7	CH3	
8	CH4	
9	CH1/CH2	Variable Gain Control
10	CH3/CH4	
11	-	"Power ON" LED indicator (Blue)

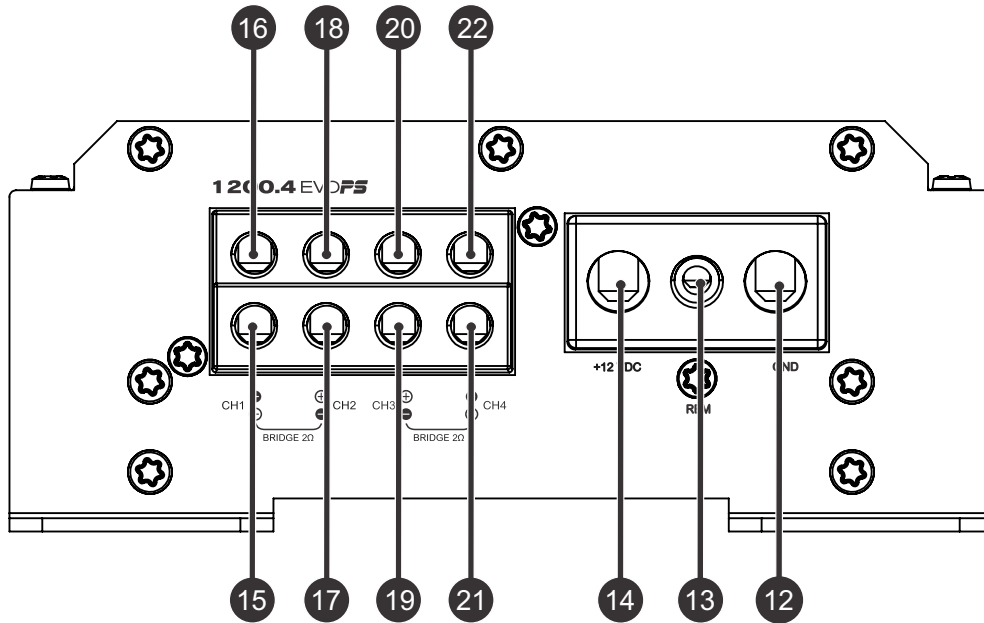

12	-	Negative power supply connector (GND)
13	-	Remote power supply connector (REM)
14	-	Positive power supply connector (+12VDC)
15	CH1	Positive speaker connector
16		Negative speaker connector
17	CH2	Negative speaker connector
18		Positive speaker connector
19	CH3	Negative speaker connector
20		Positive speaker connector
21	CH4	Positive speaker connector
22		Negative speaker connector

ELECTRICAL DIMENSIONING

For proper operation of your SounDigital amplifier, you need the proper dimensioning of the electrical system and the cables used.

The table below shows the minimum section of GND cables, +12VDC cables and speaker output cables according to the power generated by the amplifier.

1200 WRMS	POWER CABLE	16mm ² - 5 AWG
	GROUND CABLE	
	SPEAKER CABLE	2x2mm ² 12 AWG

We recommend the use of ONLY OFC (Oxygen Free Copper) Cables on the installation of our products.



BEFORE PROCEEDING WITH THE INSTALLATION, UNPLUG THE NEGATIVE TERMINAL FROM ALL OF THE BATTERIES, TO AVOID FIRE, DAMAGE TO THE AMPLIFIER AND THE USER HIMSELF

- Mount the amplifier in such a way you have access to the connectors;
- Install the power cables in the vehicle/vessel properly, starting from the battery to the fuse holder or circuit breaker, use the cable with the appropriate size. Make all connections, install fuse holders or circuit breakers, but without placing the fuses or with the circuit breakers in the "Off" position.



Warning! THE MAX: DISTANCE FOR THE INSTALLATION OF THE FUSE/CIRCUIT BREAKER IS ONE FOOT (30 CM) AWAY FROM THE BATTERY

- Connect the power cables in to the amplifier, observing the polarity. Connect all the positive cables from the fuse holder or circuit breaker to the positive connector of the amplifier and all the negative power cables from the batteries to the negative connector of the amplifier;
- The ground cable must be as short as possible and must be connected to the negative connector of battery or vehicle chassis in case of metallic chassis;

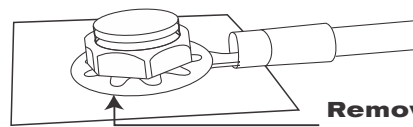

Remove the paint between the terminal and chassis

- Install the signal input cables in a proper way, distant from the power cables;
- Connect the RCA or the high signal input cables to the head unit and amplifiers;
- Install the audio output cables with the appropriate section, distant from the power and audio input cables;
- Connect the audio output cables to the amplifier and speakers respecting the positive (+) and negative (-) polarities;
- Install the remote cable with the power cables, using 1.5mm² (15 AWG) cable or thicker;
- Connect the remote power cable to the amplifier's "REM" terminal at the main unit's remote power output;
- Before powering the system, verify all the connections and make sure there are no mistakes or short-circuits on the power and ground cables;
- Reconnect the ground of the batteries;
- Check if the headunit is turned off and then place the fuses in the fuse holders or switch the circuit breakers on;
- Turn on the main unit and the amplifier will turn on the "On" LED indicating that it is in operation.

4 CHANNEL WIRING DIAGRAM

See "Audio Outputs"
on page 10

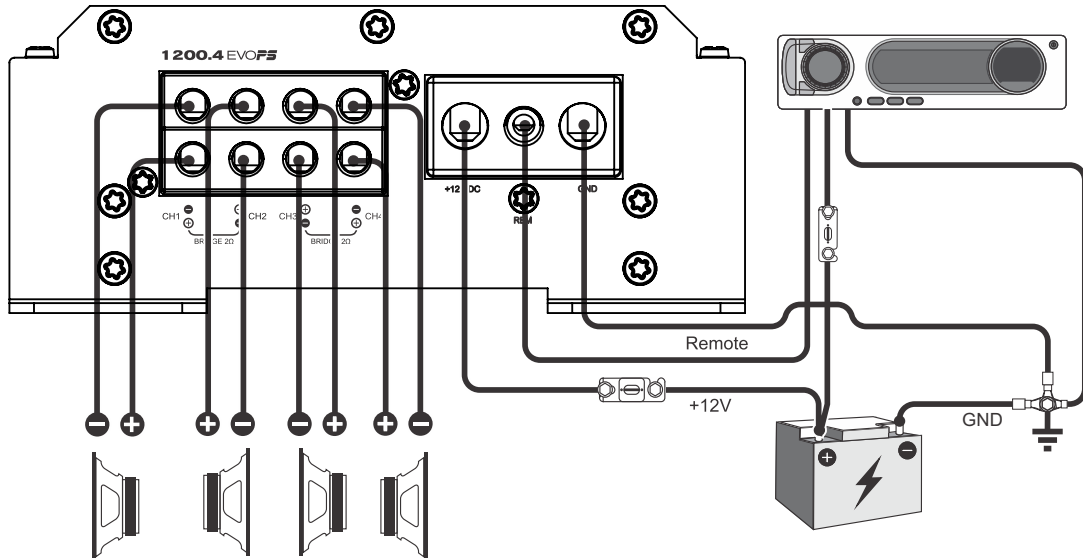

* Check the minimum speaker impedance at specs table

3 CHANNEL WIRING DIAGRAM

See "Audio Outputs"
on page 10

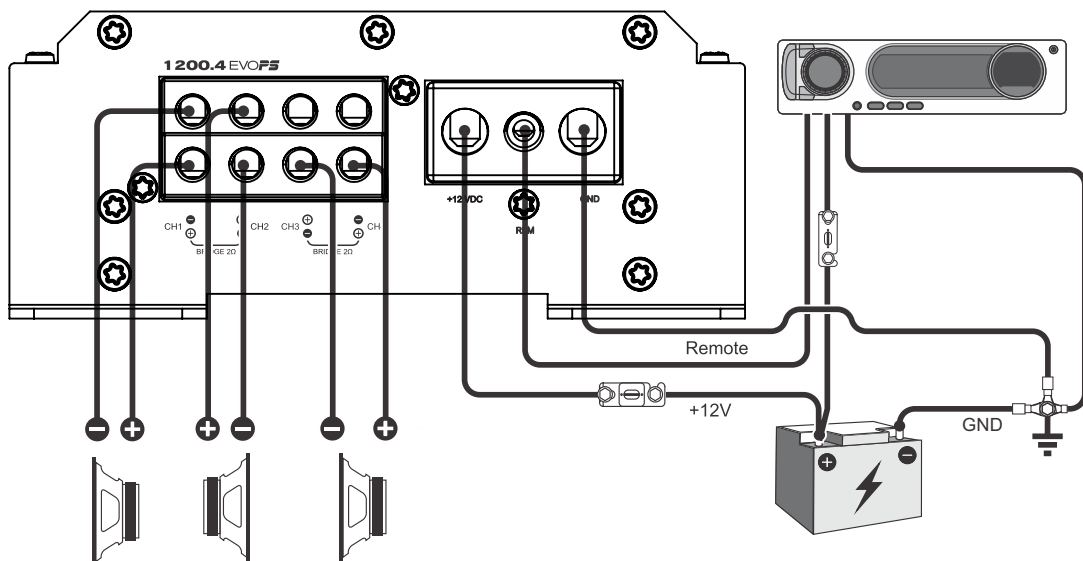

2 CHANNEL WIRING DIAGRAM

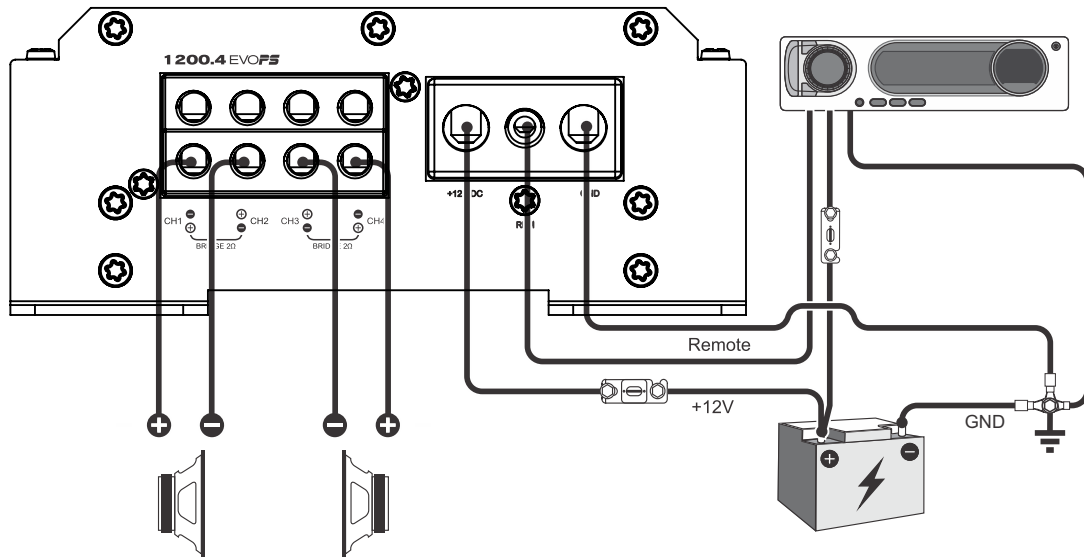

* Check the minimum speaker impedance at specs table

GAIN SETTING

- Necessary equipment:
- Digital AC voltmeter;
- Media with sine wave test tone 60Hz recorded at 0db;
- Screwdriver 1/8" (for gain set)

Set up procedure

- This procedure is the same for both gain controls;
- Turn the gain control all the way down.
- Disconnect the output cables from the amplifier outputs;
- Turn off all processing (bass, treble, loudness, EQ, etc.);
- Set the source unit volume to 3/4 of full volume.
- Set the source unit's fader control to center position;

- Set the crossover selector switch in "F"
- Use a 60Hz sine wave
- Connect the AC voltmeter to the speaker output connectors of the amplifier. Make sure you test the voltage at the correct connectors (+ and -);
- Increase the gain control until the target voltage is observed with the voltmeter (see the chart below);
- Once you have adjusted the amplifier to its correct voltage output, turn off the source unit and reconnect the speaker(s)
- *Download the tracks for set up in <https://sounddigitalusa.com/tracks-for-set-up/>*

MODEL	STEREO / POWER	BRIDGE / POWER	STEREO OUTPUT VOLTAGE	BRIDGE OUTPUT VOLTAGE
1200.4EVOFS 2Ω	1Ω / 300W	2Ω / 600W	17.3 V	34.6 V
1200.4EVOFS 4Ω	2Ω / 300W	4Ω / 600W	24.5 V	49.0 V

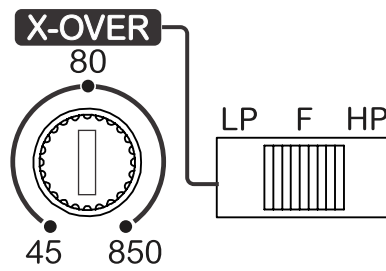

"F" All the frequencies are reproduced;

"LP " Set in the variable control on Low Pass Function;

"HP " Set in the variable control on High Pass Function.

► Selector switch to "F" position (Full Range): All the frequencies are reproduced.

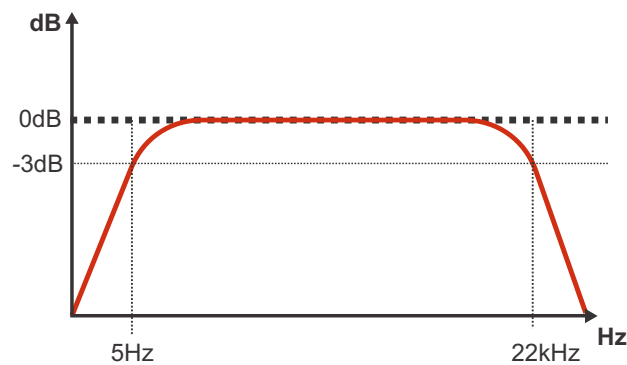

► Selector switch to "HP" - Set in the variable control between 45Hz and 850Hz ("A") where you want to perform the high pass cut filter;

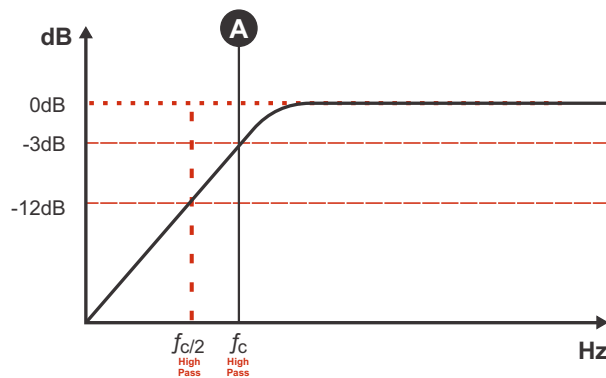

► Selector switch to "LP" - Set in the variable control between 45Hz and 850Hz ("B") where you want to perform the low pass cut filter;

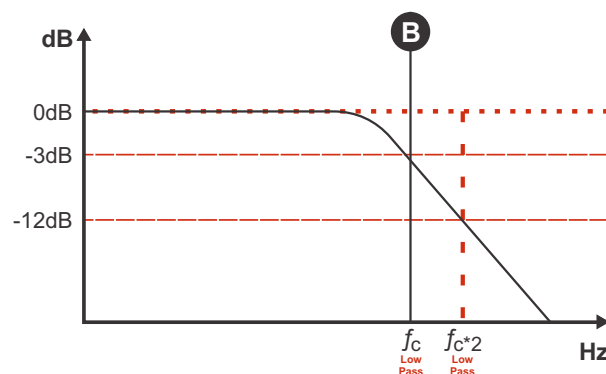

PARAMETERS	1200.4 EVOFS 2Ω	1200.4 EVOFS 4Ω
Power RMS Bridge @ 2Ω*	2 X 600W	N/A
Power RMS Bridge @ 4Ω*	2 X 396W	2 X 600W
Power RMS @ 1Ω*	4 X 300W	N/A
Power RMS @ 2Ω*	4 X 198W	4 X 300W
Power RMS @ 4Ω*	4 X 130W	4 X 198W
Frequency Response (-3dB)	5Hz ~ 22kHz	5Hz ~ 22kHz
Low Pass filter (12dB/oct)	45Hz ~ 850Hz	45Hz ~ 850Hz
High Pass filter (12dB/oct)	45Hz ~ 850Hz	45Hz ~ 850Hz
Operating Voltage	8V ~ 16V	8V ~ 16V
SNR	88 dB	91dB
Input Sensitivity	0.2 ~ 4V	0.2 ~ 4V
Current Draw (Music)	49A	50A
Current Draw (Max)	99A	101A
Total Efficiency	84%	82%
Damping Factor (@100Hz nominal impedance)	200	200
Stereo Minimum Impedance	1Ω	2Ω
Bridge Minimum Impedance	2Ω	4Ω
Fuse (music)	60A	60A
Recommended battery	70Ah	70Ah



*REAL POWER NUMBERS
CTA-2006 INDUSTRY STANDARDS

DIMENSIONAL DATA

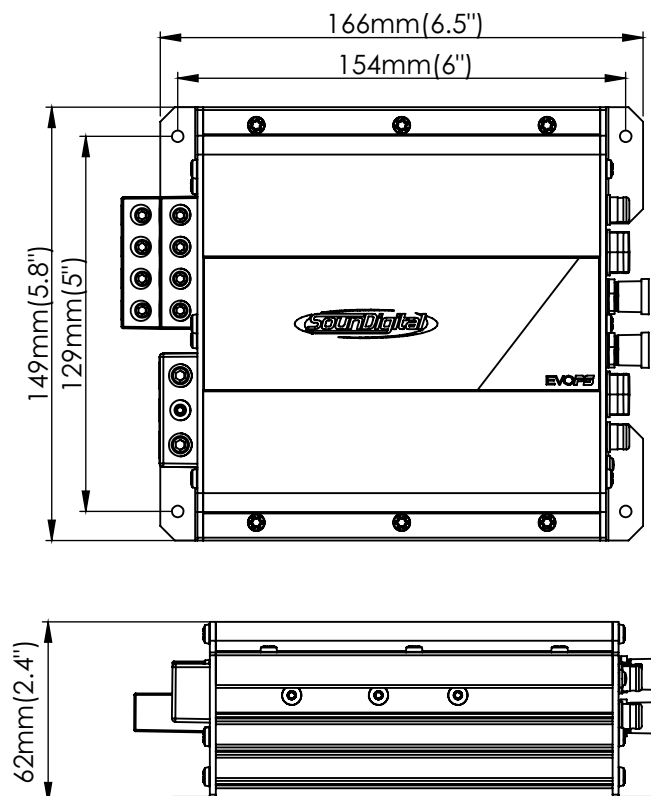



POWER SPORTS

EVO^{PS}



Consumer
Technology
Association™



WWW.SOUNDIGITALUSA.COM



[SOUNDIGITALUSA](https://www.facebook.com/SOUNDIGITALUSA)



[SOUNDIGITALUSA](https://www.instagram.com/SOUNDIGITALUSA)