

spex

Zygo Back Support Drop Mount Hardware *Installation & User Manual*

IMPORTANT CONSUMER INFORMATION NOTICE:

This manual contains important instructions that must be passed on to the user of this product. Please do not remove this user manual before delivery to the end user.

SUPPLIER: This manual must be given to the user of this product.

USER/CAREGIVER: Before using this product, read entire manual and save for future reference. Transit Safety section **MUST** be read before product is used in a vehicle.

MD: This product is a Medical Device.

User Name

Serial Number

Contents

Introduction	2
Intended Use	3
Compatibility	4
General Safety	4
Back Support Contents	5
Warnings	6
Installing Drop Mount Hardware	7
Transport Safety	9
Maintenance	13
Cleaning Checklist	13
Reissuing to another user	14
Disposal and Recycling	15
Product Materials	15
6 Month Checklist	16
Product Log Form	17
Warranty	18

Introduction

Spex recommends that a health care professional who is skilled in wheelchair seating should decide if the Spex products are appropriate for the user. They could be an Occupational Therapist, Physiotherapist, or other health professional with training in wheelchair seating and positioning.

Installation and adjustment of your Spex product should be carried out by

- An authorized Spex distributor or technician, or
- A qualified health professional with appropriate training

Weight Capacity

Drop Mount Hardware maximum user weight: 300 lbs. (136 kg)

Never exceed the weight limit of your Back Support or your wheelchair. The weight limit of the wheelchair is specified by the wheelchair manufacturer. Never perform exercise weight training that could exceed the weight limit of the wheelchair.

Intended Use

Spex Seating is intended for users (disabled and/or discomforted) that require specific postural and positioning support to provide comfort for body function in a sitting posture on wheelchairs for daily activities and for transportation in vehicles. It is designed with ergonomic adjustments to provide improved personal body-posture conditions and/or to help prevent/reduce physical problems associated with sedentary work or activities.

Contraindications

- 1.** Use of Spex Wheelchair seating products may affect the center of gravity causing the Wheelchair to tip, potentially causing injury. Always judge the need for anti-tippers or amputee axle adapter brackets to be added to the Wheelchair to increase stability.
- 2.** Check regularly for skin redness and that pressure spots are not developing. If your skin develops redness, stop using the product and consult your doctor or therapist.
- 3.** Zygo Lo is not to be used as a seat to transport a user.

Spex Products

- Seat Base
- Spex Cushions
- Back Supports
- Lateral Trunk Supports
- Arm & Thigh Supports
- Medial Thigh Supports
- Head Supports
- Anterior Supports

Find out more here: <https://www.spexseating.com/download-spex-catalogue>

Compatibility

Spex Seating is designed to be compatible with most wheelchairs. Never use your Spex product in ways it is not designed for.

All Spex products are tested and certified as part of a complete Spex Seating system and may not be suitable for use with other brands of wheelchair seating.

Back Support

- Spex offers different hardware options that can be used with most wheelchairs that have back support canes. There are options to fit tube diameters between 19mm ($\frac{3}{4}$ ") and 32mm (1 $\frac{1}{4}$ ").
- Some Back Supports can be mounted to wheelchairs without back support canes, including power-recline designs. Contact your Spex Seating supplier to check compatibility.

General Safety

To avoid injury, read and understand all warnings in this manual. Follow all instructions when installing and using your Spex product.

There are many hazards when using wheelchairs and adaptive equipment. If you misuse your wheelchair or seating products, you can be seriously injured. If your Spex product does not function as intended, please stop using it and contact your Spex Seating supplier immediately.

Any serious incident that has occurred in relation to this product should be reported to Spex Ltd. Please contact Spex Ltd, your Spex Seating supplier, and your local regulatory authority for more information.

Pressure: Inspect your skin at least once a day for any areas of redness or bruising. These could be signs of soft tissue breakdown. If your skin is red or bruised, please stop using the product and consult with your health care professional.

Skin: In rare cases people may experience skin irritation from the fabrics used in this product. If your skin is red or itchy, consult with your health care professional.

Moisture: Always keep your Spex product dry. If your Spex product gets damp or wet, wipe with a dry cloth as soon as possible. Never use your Spex product in a showering or pool facility. Moisture can damage your Spex product and could potentially cause failure.

Temperature: Keep your Spex product away from sources of extreme heat or extreme cold to avoid burns from the metal components. Extreme temperatures can affect the function of your Spex product.

Dirt: Small bits of dust, dirt and sand can damage your Spex product. Regularly remove any build-up around openings and moving parts.

Back Support Contents

Your Back Support contains the following, in addition to the Back Support foam, inner cover, outer cover and foam positioning kit.

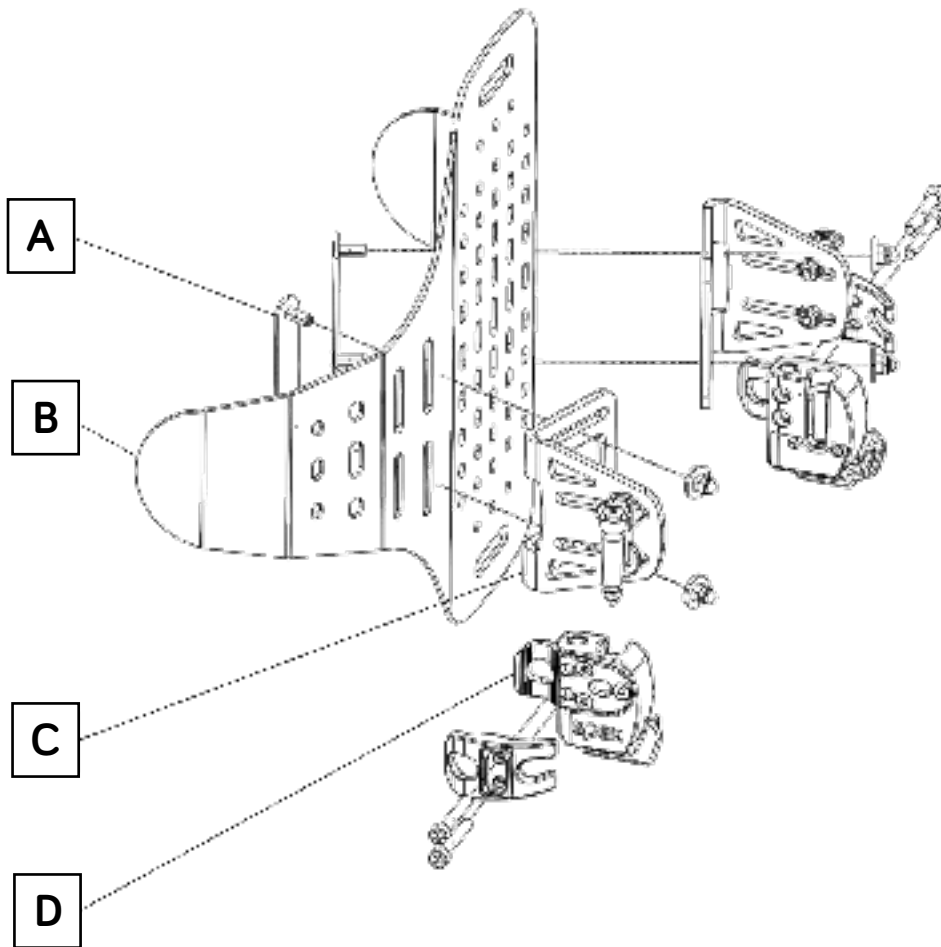

	Description	Quantity
A	Fixing Studs	2
B	Back Support Shell	1
C	Mounting Bracket	2
D	Drop Mount Receiver	2

Warnings

Risk of accident, injury, pain, or death if warnings are not followed.

Ask for help if you are unsure about any of the following points.

1. Do not install any Spex products without first reading and understanding this manual. If you are unable to understand the Warnings, Cautions, and/or Instructions, contact a qualified clinician or supplier - otherwise injury or damage may occur.
2. Check all hardware is installed correctly and tightened before using the wheelchair.
3. Do not use your Spex product if any hardware is missing or broken. You will need a qualified technician for help with any repairs, replacements, or adjustments.
4. Check that any mechanisms are functioning correctly before the wheelchair is used. Accidental release may cause parts to detach and cause injury.
5. Only use genuine Spex accessories, components, and hardware.
6. Installing Spex products may change the centre of gravity of your wheelchair. Check that the wheelchair is not at risk of tipping over from steep slopes or user motion. Consider adding anti-tippers to the wheelchair to increase stability.
7. Never use any Spex product to lift or push the wheelchair.
8. Check that the Spex product gives the user appropriate support. A poor fit can cause posture problems and risk the safety of the user.
9. Never use Spex products without their covers. Using the product without its cover increases the risk of skin irritation or breakdown.
10. Use only Spex covers on Spex products.
11. Avoid sharp objects, open flames, and extreme temperatures.
12. Be careful when transferring the user in and out of the seating system. The user could fall from the wheelchair or injure themselves when supports are removed.
13. Watch out for pinch points. Keep all body parts clear of moving parts when making changes and adjustments.
14. Never exceed the weight limit of your Spex product or your wheelchair. The weight limit of the wheelchair is specified by the wheelchair manufacturer. Never perform exercise weight training that could exceed the weight limit of the wheelchair.

Installing Drop Mount Hardware



5mm Hex Key, 10mm Spanner/Wrench

- 1.** Attach the Drop Mount Receivers to the wheelchair canes. Check that both receivers are level and parallel.
- 2.** Apply enough tension to the clamp fasteners to prevent the receivers from slipping during installation.
- 3.** Adjust the mounting bracket fasteners to allow the brackets and pegs to slide freely.
- 4.** Drop the Back Support into the receivers. Check that both pegs are fully engaged.
- 5.** Position the Back Support depth and angle as desired. Tighten the two M6 Nyloc Nuts on each peg.

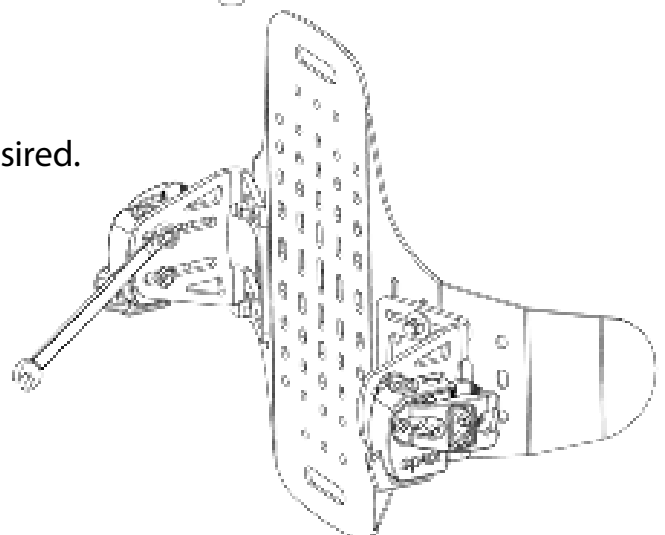
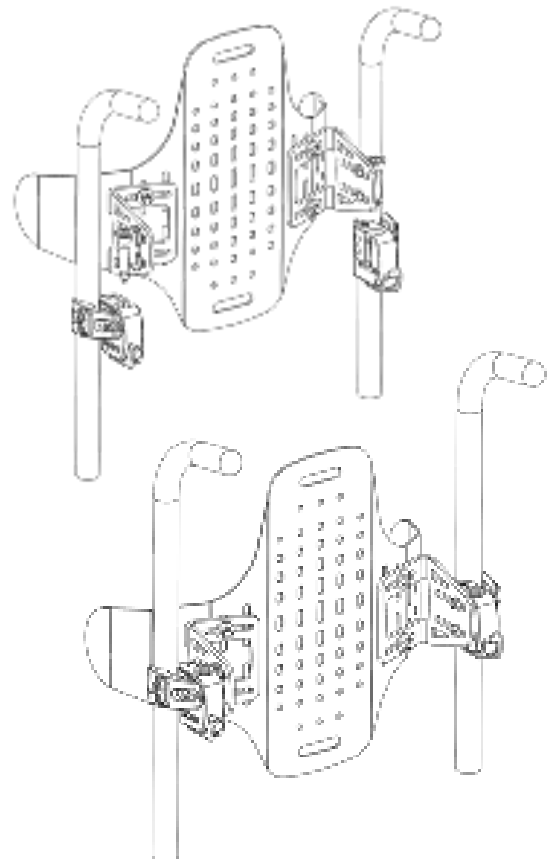
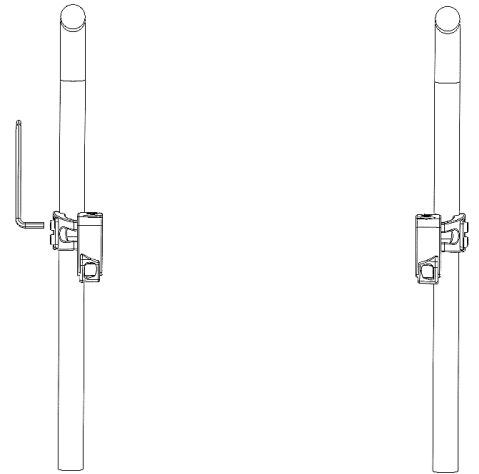

- 6.** Check that the Back Support is centred between the canes and the Mounting Brackets are flat against the Back Support Shell.
- 7.** Position the Back Support height as desired. Tighten the two M6 Nyloc Nuts on each bracket.
- 8.** Flick the red levers towards the outside of the canes to release the locking mechanism.
- 9.** Test the Back Support removal and installation. The pegs should lock securely into both receivers. Adjust the receiver, peg, or bracket positions if needed.
- 10.** Evenly torque both clamp fasteners to 5Nm. Check both fasteners are tight.

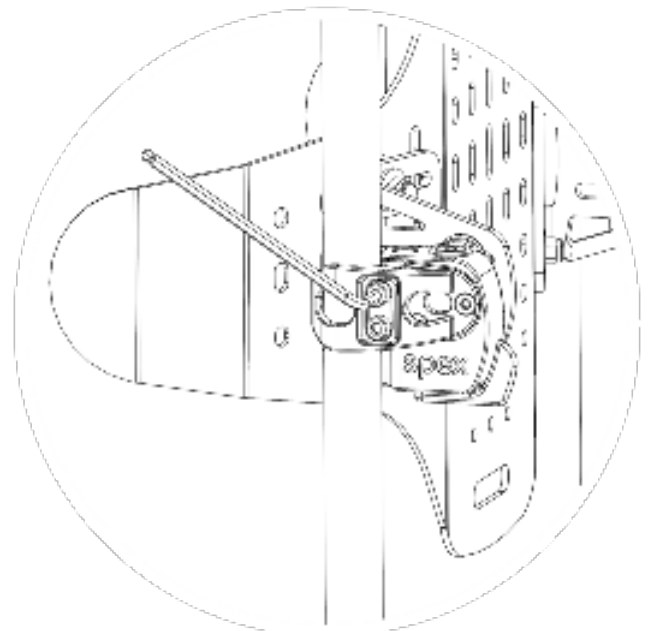
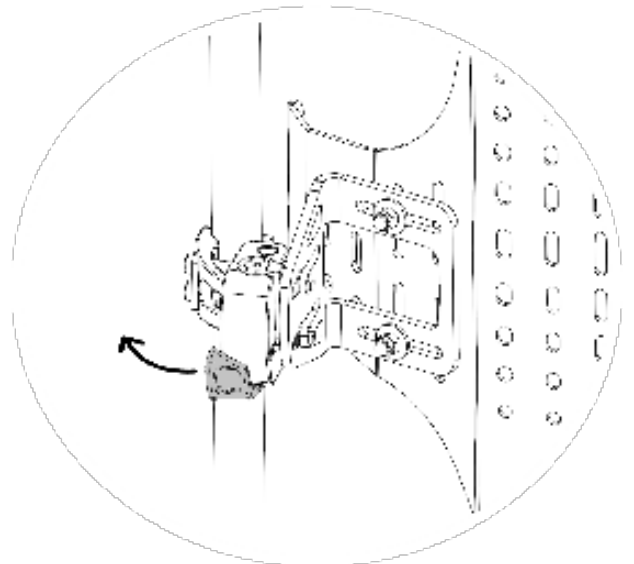
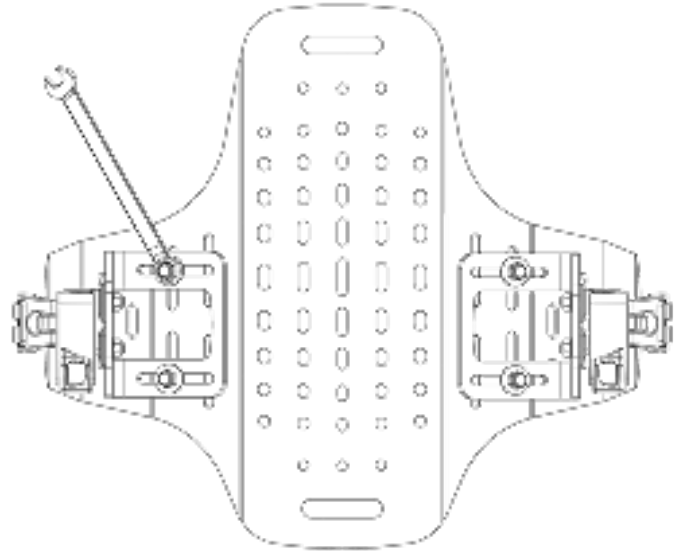

Transport Safety

The Spex seating system has been successfully crash tested and complies with RESNA WC-4:2012, Section 20 and ISO 16840-4:2009, it is suitable for use as a motor vehicle seat when used with an appropriate wheelchair base.

Please follow all installation, use and maintenance instructions as well as the following transit instructions. If feasible, the wheelchair user should transfer to the vehicle seat and use the vehicle-installed occupant restraint systems.

Spex seating system has been designed to accommodate the proper use of vehicle-anchored belt restraints. Spex achieved a rating of Excellent (16 out of 16), for ease of properly positioning a belt restraint, and the degree to which proper belt restraint can be achieved, based on the methods of Annex C. The following items of the Spex seating system have been tested and are suitable for use in a motor vehicle:

- Back Support range (when sized to support pelvis and shoulders)
- Seat Base
- Cushion Range
- Arm and Thigh Supports
- Trunk Lateral Supports
- Head Supports

Note: All back supports must be used with a head support for transport in a vehicle. Zygo Lo is not certified for transport in a vehicle.

Transport Checklist

- After carrying out any adjustments ensure all bolts, screws and nuts are securely fastened again to ensure safety when travelling in a vehicle.
- Ensure the top and bottom mounts of the backrest are installed as far apart from each other as possible to give a stronger 4-point attachment to the wheelchair frame. Ensure the quick release latches are engaged.
- Ensure the front and rear mounts of the seat base are mounted (in the designated locations) as far forward as possible to provide maximum support. Ensure the quick release pins are engaged.
- Do not use the Spex seating system as a means of vehicle seat if seating components which have not been successfully crash tested are used anywhere on the seating system. Spex seating is designed and certified using only Spex components.
- Spex is not liable in the event where other manufactured seating systems are used in conjunction with Spex seating.
- Ensure any swing-away or quick-release components are in their locked position before using the seat as a vehicle seat in a motor vehicle.
- Ensure the user is below the weight limit of both the wheelchair and the seating system. Contact your Spex Seating supplier to review options if the user weight has increased and exceeds the specified limit.

Belt Restraints

When using the Spex seating system as a vehicle seat, both a pelvic belt restraint and shoulder belt restraint must always be used. To correctly position the belt restraints on the wheelchair occupant, the following must be ensured:

- The pelvic-belt restraint should be worn low across the front of the pelvis near the junctions of the pelvis and thighs
- The angle of the pelvic-belt restraint should be between 30° to 75° relative to the horizontal and, ideally, between within 45° to 75° to the horizontal (as shown in Figure 2)
- The belt-restraint buckle of three-point belt restraints should be placed in contact with the occupant's body and away from wheelchair components
- The junction of the shoulder belt and pelvic belt of three-point-belt restraints should be located near the hip opposite the shoulder over which the diagonal belt crosses and not near the midline of the occupant
- Shoulder belt restraints should fit over the shoulders with the shoulder belt restraint midway between the shoulder and neck.
- Belt restraints should not be routed outside of the wheelchair wheels or over the wheelchair armrests, and should not be held away from the body by wheelchair components or parts
- Upper-torso belt restraints should fit directly over, and in contact with, the middle of the shoulder
- Belt restraints should be adjusted to fit as snugly as possible, consistent with user comfort
- Belt restraints should not be worn twisted in a manner that reduces the area of contact of the belt webbing with the occupant



Warning

Pelvic belt restraints should make good contact with the front and sides of the body near the junctions of the thighs and pelvis and against the hips

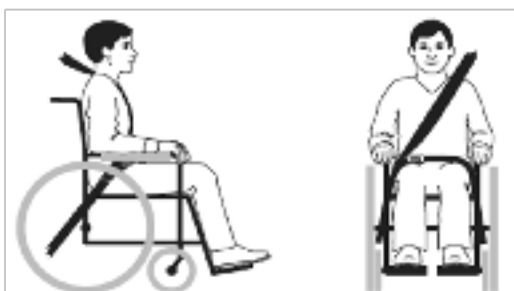

Belt restraints must not be held away from the body by wheelchair components such as armrests or wheels



Transit Warnings

1. The distance between the top of the user's shoulder and the top of the back should not exceed 165mm (6.5").
2. The Spex seating system must only be used for transport with wheelchair bases that are tested as part of a wheelchair system that conforms to performance requirements of ISO 7176-19 and RESNA WC-4:2012, Section 19.
3. The Spex seating system should only be used for transport on wheelchair frames that provide four securement points strap-type tiedowns and pelvic-belt anchor points that conform to the requirements of RESNA WC-4: 2012, Section 19.
4. The wheelchair must be labelled as appropriate for use as a seat in a motor vehicle, dynamically tested to the performance requirements of ISO 7176-19 and installed, used and maintained according to the manufacturer's instructions.
5. The Spex seating system must only be used as indicated in this user manual.
6. Both pelvic and shoulder belt restraints as a part of a complete Wheelchair Tie down and Occupant Restraint System (WTORS) which meets ISO 10542-1 shall be used to achieve effective occupant restraint and optimum protection in a vehicle impact; the belt restraints should be compatible with the specific wheelchair, and fitted to the user in accordance with WTORS manufacturer's instructions.
7. Back supports with adjustable recline angles should not be tilted back more than 30° to the vertical during travel in vehicles unless necessary for the medical and postural needs of the occupant.
8. If the back support must be adjusted to an angle that is greater than 30° to the vertical during travel, the upper shoulder-belt anchor point should be adjusted rearward to maintain belt contact with the wheelchair occupant's shoulder and chest.
9. The Spex seating system must only be used for forward-facing seating in motor vehicles.
10. In order to reduce the potential of injury to vehicle occupants, wheelchair-mounted rigid trays not specifically intended for use during travel in motor vehicles must be:
Removed and secured separately in the vehicle or secured to the wheelchair so they will not break free in a crash and
 - Be positioned with a gap of at least 75mm (3") between the back edge of the tray and the wheelchair occupant's abdomen and/or chest so as not to interfere with the proper belt restraint use, and
 - Have energy absorbing padding placed between the back edge of the tray and the wheelchair occupant.
11. Alterations or substitutions must not be made to the seating system structure, parts or components, without first consulting Spex.
12. The use of a postural pelvic belt and upper torso belt attached to the wheelchair base or seat frame are strongly recommended.

13. Postural support devices that are not labelled as conforming to ISO 16840-4 may be used when in a vehicle, but should not be relied on for occupant restraint.
14. Both pelvic-belt and shoulder-belt restraints as a part of a complete WTORS which meets ISO 10542-1 or ANSI/RESNA WC18 shall be used to achieve affective occupant restraint and optimum protection in a vehicle impact; the belt and restraints should be fitted to the user in accordance with the WTORS manufacture's instructions
15. Backrest mounting hardware must be installed correctly. Refer to the appropriate section for correct backrest hardware mounting instructions.
16. If the wheelchair is being transported whilst unoccupied, the wheelchair must still be secured to the WTORS.
17. Children whose mass is less than 22kg (48.5 lbs) should be transferred from their seating system into appropriate child restraint systems intended for use in motor vehicles.
18. Always use appropriate restraints in a vehicle.
19. Sufficient forward and rearward clear space should be provided around the wheelchair occupant. Forward clear-space zone (FCZ) needs to be larger when a shoulder-belt restraint is not used

FAILURE TO HEED THESE WARNINGS COULD CAUSE SEVERE INJURY TO THE WHEELCHAIR USER OR OTHERS.

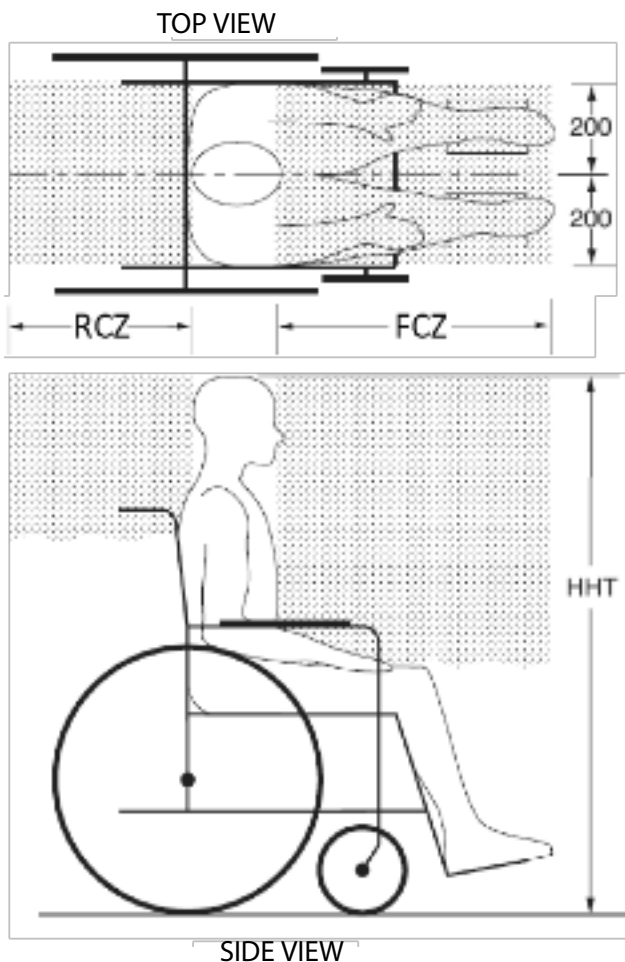

NOTES: The rear clear zone is measured from the rearmost point on an occupant's head. The front clear zone is measured from the frontmost point on an occupant's head. Seated head height (HHT) ranges from about 1200 mm for a small adult female to about 1550 mm for a tall adult male.

FCZ = 650mm (25.6") with upper-torso restraint
 = 950mm (37.4") with only pelvic restraint

NOTE: It is strongly recommended that both pelvic and upper-torso belts be used.

Maintenance

The expected lifetime of Spex products is 5 years. Your Spex product should be checked and cleaned regularly to help extend its life. Spex recommends that the product is checked every 6 months. If any issues are found, please stop using the product and contact your Spex Seating supplier immediately.

Maintenance Checklist

- Check that the hardware is working correctly.
- Look for loose bolts or broken components.
- Examine any hardware for signs of stress or cracking.
- Tighten any loose fasteners.
- Check the consistency of any foam.
- Look for signs of wear in any stitching, webbing & pads.
- Contact your Spex Seating supplier for any product repair and replacement options.

Cleaning Checklist

Spex takes no responsibility for the results of the cleaning process. If you have any questions about cleaning procedures, please contact your Spex Seating dealer.

Hardware

- Wipe clean with mild detergent and water.
- Use disinfectant wipes. Medifab recommends using AHP (Accelerated Hydrogen Peroxide) wipes.
- Dry thoroughly after wiping.

Outer Covers

- Remove the cover and turn inside out. Close any zips or Velcro.
- Machine wash in warm water (40° C / 104° F).
- Drip or tumble dry on low heat.
- Do not iron. Do not dry clean. Do not bleach.
- If chemical cleaners are used, rinse cover with water to remove all chemical residue and dry completely before use.
- Check the cover for tears and excessive wear and replace if ripped, torn or broken.
- Carefully reinstall any covers after washing. Check the panels and seams of the cover match up to the foam.
- If used in a group care environment, write the user's name on the label. Do not mix covers between users.

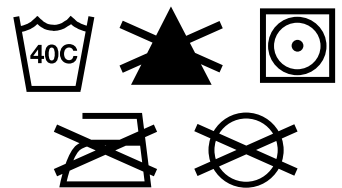

Incontinence Covers

- Hand wash only with mild detergent and water.
- Do not use bleach or other strong cleaners.
- Do not tumble dry.
- Using this cover will help extend the life of your cushion.

Foam

- Keep dry. Do not reinstall a cover on to damp foam.

Harnesses

- Place inside a laundry bag to prevent damage to your harness or washing machine/dryer.
- Machine wash in warm water (40°C / 104°F).
- Drip or tumble dry on low heat.
- Do not iron. Do not bleach.

Re-issuing to another user

There are strict guidelines for refurbishing Spex products before giving them to another user. Spex takes no responsibility for contamination, cross-infection, or damage.

Spex recommends using AHP (Accelerated Hydrogen Peroxide) disinfectant wipes. Follow the manufacturer instructions when using the disinfection product. Spex takes no responsibility for the results of the disinfecting process.

Part	Procedure
Safety check	Check all components for signs of stress or cracking. If any stress or cracks are found, the Spex product must be condemned and disposed of.
Seat Base, Back Support shell	Clean the product with a mild detergent and quality disinfectant to make sure all areas are free from dirt.
Hardware and components	Ensure the mechanism components are secure and in safe working order. If any parts are missing, new ones must be ordered. Clean the hardware with mild detergent and a quality disinfectant to make sure all areas are free from dirt.
Upholstery covers	Replace all covers regardless of condition.
Cushion positioning base and wedges	Check each contouring pocket has the correct layers of foam pads. Check all Velcro is in good condition and holds strong. Ensure Flex cushion contains entire kit of wedges and pelvic pads.
Cushion and Back Support Foam	Check for degradation and cleanliness. Replace if not in good condition.
Head, Lateral, Medial Support Pads	Replace the foam pad and covers regardless of condition.

Disposal and Recycling

Many of the materials in your Spex Seating system can be recycled by taking it to a recycling centre. Thank you for looking after the environment! Follow all local laws and regulations when disposing of your Spex product.

Product materials

Seat Base

Aluminium, Stainless Steel, Nylon

Spex Cushion: Vigour Cushion: Flex Cushion: Dualtec cushion

Polyurethane foam, Lycra, Nylon, Polyester, Polyurethane

Back Supports

Hardware: Aluminium, Steel, Plastics

Upholstery: Polyurethane foam, Lycra, Nylon, Polyester,

Laterals Trunk Supports

Hardware: Aluminium, Rubber

Upholstery: Polyurethane foam, EVA Foam, Lycra, Nylon, Polyester,

Arm & Thigh Supports

Hardware: Aluminium, Stainless Steel, Ply wood

Upholstery: Polyurethane foam, EVA Foam, Lycra, Nylon, Polyester,

Medial Thigh Supports

Hardware: Aluminium, Stainless Steel

Upholstery: EVA Foam, Lycra, Nylon,

Head Supports

Hardware: Aluminium, Stainless Steel

Upholstery: Polyurethane Foam, Lycra, Nylon, Polyester

Anterior Supports

Upholstery: Polyurethane foam, Nylon, Polyester,

6 Month Checklist

The 6 month checklist is a compulsory check to ensure that your Back Support is maintained in a safe and functional condition. The examiner must check each item on the checklist and place the date and their initials in the appropriate column for that check. Failure to perform these checks may void warranty.



Checklist		Date: ✓ or ✗	Date: ✓ or ✗	Date: ✓ or ✗	Date: ✓ or ✗	Date: ✓ or ✗	Date: ✓ or ✗
Health & Safety	No concerns with the overall safety of the user? If ✗, contact your therapist or Spex distributor immediately.						
	No accidents occurred or harm caused?						
	No abnormal stress caused to the seating?						
	User is wearing an appropriate lap belt and harness?						
	No bags or appendages present on the seating which may cause stability issues?						
	User is under the maximum weight capacity?						
Hardware	Are the mounting clamps secured properly to the wheelchair canes?						
	Are the quick release latches properly engaging?						
	Are the nuts on the L-brackets and pins secured?						
	Can the Back Support be removed & installed properly?						
Hygiene	Are all hardware and fasteners tight?						
	Are all components clean?						
	Are the covers clean and washed?						
User Posture	Is the cushion maintaining correct support and control for the user's pelvis?						
	Is the cushion adjusted correctly and not modified adversely?						
	Is the cushion installed the right way on the wheelchair?						
	Does the Back Support maintain correct support and control?						
	Is the Back Support adjusted correctly and not modified adversely?						
Transit (if applicable)	Are the laterals adjusted correctly?						
	Is the headrest adjusted correctly?						
	Is a certified Wheelchair Tie-down & Occupant Restraint System being correctly used?						
	Is set-up as per the Transit Safety section and Warnings in this user manual?						
	Is the primary caregiver knowledgeable about the above points?						

Warranty

Each Spex product is carefully inspected for performance and is guaranteed to be free from defects in materials and workmanship for a specified period from the date of purchase when used in normal conditions. Should a defect in materials or workmanship occur within this period, Spex will, at its discretion, repair or replace it without charge.

This warranty includes hardware, foam padding, outer covers, incontinence cover and peripheral supports. This warranty does not apply to the general wear and use, including punctures, tears or burns or customer abuse of any of the components.

Back Supports and Vigour, Spex and Flex Cushions	24 months
Dualtec Cushion, Seat Base and all other accessories	12 months

Claims and repairs should be processed through the nearest authorized Spex supplier. Except for express warranties made herein, all other warranties, including implied warranties of merchantability and warranties of fitness for a particular purpose are excluded. There are no warranties which extend beyond the description on the face hereof. Remedies for breach of express warranties herein are limited to repair or replacement of the goods. In no event shall damages for breach of any warranty include any consequential damages or exceed the cost of non-conforming goods sold.



32 Detroit Drive
Rolleston 7675
New Zealand



spex

Spex Ltd
Phone +64 3 307 9790
Fax +64 3 307 2820
fasterresults@spexseating.com
www.spexseating.com

US	REP
Medicept 200 Homer Ave, Ashland, MA 01721 United States Tel: +1-508-231-8842	

EC	REP
BEO MedConsulting Berlin GmbH Helmholtzstr. 2 D-10587 Berlin, Germany Tel: +49-30-318045-30	