

## Desk Monitor Riser - 3.5in (9cm) Tall - 33lb (15kg) Weight Capacity

### Product ID

1MFSW-MONITOR-RISER

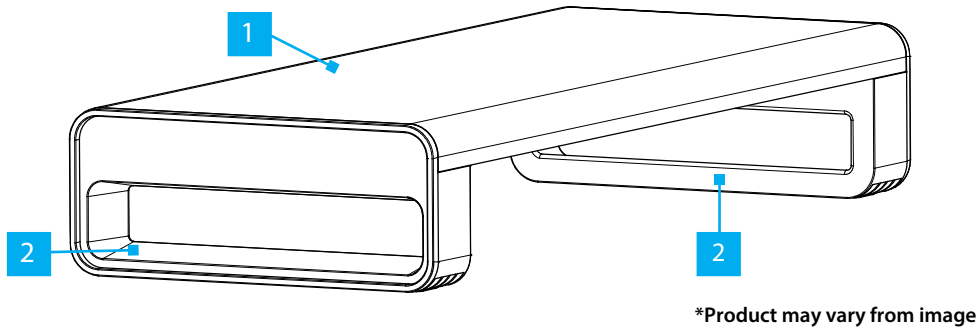

	Component	Function
1	Monitor Riser Stand	• Supports a <b>Monitor</b> up to 33lb (15kg)
2	Riser Supports	• Support the weight of the <b>Monitor Riser Stand</b>

### Package Contents

- Monitor Riser Stand x 1
- Riser Supports x 2
- Rubber Feet x 4
- Screws x 4
- Quick-Start Guide x 1

### Requirements

For the latest requirements, please visit [www.startech.com/1MFSW-MONITOR-RISER](http://www.startech.com/1MFSW-MONITOR-RISER)

- Phillips head screwdriver

### Installation

#### Assemble the Desk Monitor Riser

1. Carefully remove the adhesive backing of the **Rubber Feet** (x 4). Attach the **Rubber Feet** into the designated Pockets on the **Left** and **Right Riser Supports**. (Figure 1)

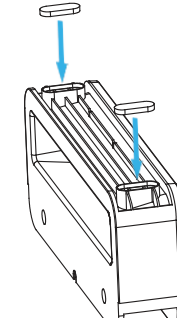

Figure 1

2. Place one of the **Riser Supports** onto the bottom of the **Monitor Riser Stand** ensuring the **Assembly Tabs** fit inside the **Riser Support**. Insert the **Screws** (x 2) through the **Riser Supports** and into the **Assembly Tabs**. Use a **Phillips Head Screwdriver** to tighten the **Screws** (x 2). (Figure 2).

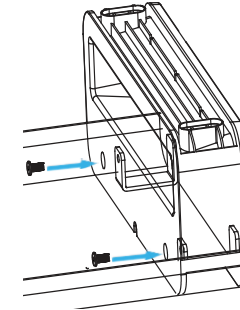

Figure 2

3. Repeat **Step 2** with the remaining **Riser Support**. (Figure 3)

**Regulatory Compliance**

**Use of Trademarks, Registered Trademarks, and other Protected Names and Symbols**

This manual may make reference to trademarks, registered trademarks, and other protected names and/or symbols of third-party companies not related in any way to StarTech.com. Where they occur these references are for illustrative purposes only and do not represent an endorsement of a product or service by StarTech.com, or an endorsement of the product(s) to which this manual applies by the third-party company in question. StarTech.com hereby acknowledges that all trademarks, registered trademarks, service marks, and other protected names and/or symbols contained in this manual and related documents are the property of their respective holders.

PHILLIPS® is a registered trademark of Phillips Screw Company in the United States or other countries.

**Warranty Information**

This product is backed by a 5-year warranty.

For further information on product warranty terms and conditions, please refer to [www.startech.com/warranty](http://www.startech.com/warranty).

**Limitation of Liability**

In no event shall the liability of StarTech.com Ltd. and StarTech.com USA LLP (or their officers, directors, employees or agents) for any damages (whether direct or indirect, special, punitive, incidental, consequential, or otherwise), loss of profits, loss of business, or any pecuniary loss, arising out of or related to the use of the product exceed the actual price paid for the product.



**StarTech.com Ltd.**  
45 Artisans Crescent  
London, Ontario  
N5V 5E9  
Canada

**StarTech.com LLP**  
4490 South Hamilton  
Road  
Groveport, Ohio  
43125  
U.S.A.

**StarTech.com Ltd.**  
Unit B, Pinnacle 15  
Gowerton Road  
Brackmills,  
Northampton  
NN4 7BW  
United Kingdom

**StarTech.com Ltd.**  
Siriusdreef 17-27  
2132 WT Hoofddorp  
The Netherlands

FR: [startech.com/fr](http://startech.com/fr)  
DE: [startech.com/de](http://startech.com/de)  
ES: [startech.com/es](http://startech.com/es)  
NL: [startech.com/nl](http://startech.com/nl)  
IT: [startech.com/it](http://startech.com/it)  
JP: [startech.com/jp](http://startech.com/jp)