

## IMPORTANT INSTRUCTIONS

When using an iron, basic precautions should always be followed, including the following:

### READ ALL INSTRUCTIONS BEFORE USING

1. Only use an iron for its intended use.
  2. To avoid the risk of electric shock, do not immerse the iron in water or other liquids.
  3. Always turn the iron OFF before plugging or unplugging the iron from the electrical outlet. Never pull on the cord to disconnect the iron from the electrical outlet; instead, grasp the plug and pull on the plug to disconnect the iron.
  4. Do not let the cord touch hot surfaces. Let the iron cool completely before putting the iron away. Coil the cord loosely around the iron when storing.
  5. Always disconnect the iron from the electrical outlet before filling the iron with water, emptying the water from the iron, and when the iron is not in use.
  6. Do not operate the iron with a damaged cord or in the event the iron has been dropped, damaged or is leaking. To avoid the risk of electric shock, do not disassemble the iron. Take it to a qualified serviceman for examination and repair. Incorrect assembly might result in a risk of electric shock when the iron is used after reassembly.
  7. Close supervision is required for any appliance used by or near children. Do not leave the iron unattended while the iron is connected or on an ironing board.
  8. Burns can occur from touching hot metal parts, hot water, or steam. Use caution when you turn a steam iron upside down – there might be hot water in the reservoir.
  9. To avoid a circuit overload, do not operate an iron on the same circuit with another high wattage appliance.
  10. If an extension cord is absolutely necessary, a cord with an ampere rating equal to or greater than the maximum rating of the iron shall be used. A cord rated for less amperage can result in a risk of fire or electric shock due to overheating. Care shall be taken to arrange the cord so that it cannot be pulled or be tripped over.
  11. This appliance is not intended for use by persons (including children) with reduced physical, sensory or mental capabilities, or lack of experience and knowledge, unless they have been given supervision or instruction concerning use of the appliance by a person responsible for their safety. Children should be supervised to ensure that they do not play with the appliance.
  12. Always unplug electric iron before filling the water reservoir.
  13. Do not open water reservoir during use.
  14. Always use and rest appliance on a heat resistant, dry, stable, level surface.
  15. To reduce the risk of contact with hot water emitting from steam vents, check appliance before each use by holding and facing it away from the body and operating steam button.
  16. When filling the water reservoir, do not allow water to drip onto the floor.
  17. To avoid personal injury and damage to the appliance, only add water to the water reservoir. Never add cleaning solutions, perfumes, oils or any other chemical additives.
  18. The use of attachments not recommended or sold by the appliance manufacturer may cause injuries or void your warranty.
  19. Use caution while operating the appliance due to the emission of steam.
  20. For models with retractable cords: Always hold plug while retracting the cord.
- For Cordless Irons:**
21. Only use the stand provided.
  22. Place the iron on its stand after use. Make sure the stand is placed on a heat resistant, dry, stable, level surface.

## SAVE THESE INSTRUCTIONS HOUSEHOLD USE ONLY

### MODELS WITH POLARIZED PLUGS:

North American models with polarized plugs:

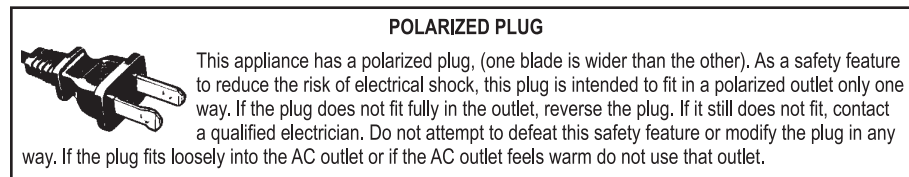

### FEATURES

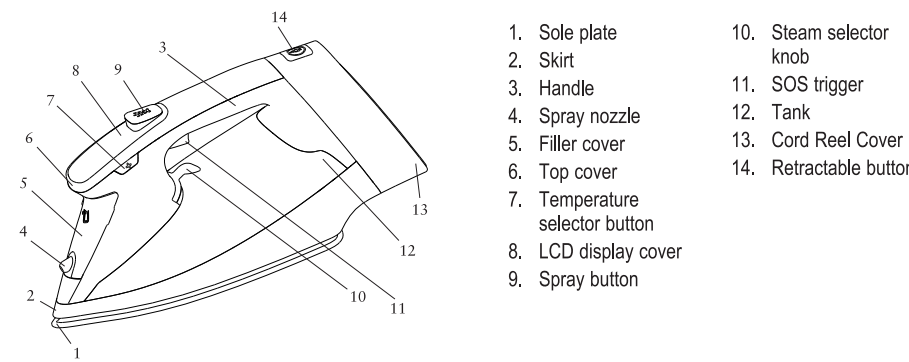

### DRY IRONING

1. Ensure Steam Lever is turned to the ☼ (Dry) setting.
2. Plug the cord into a 120-Volt AC outlet.
3. Press Fabric Select Button to select desired fabric setting. Allow iron to heat until the light under selected fabric setting turns solid blue. While iron is heating, make sure it is sitting on a stable, protected surface. Light will blink until temperature is reached.

**NOTE:** While Steam Lever is turned to the ☼ (Dry) setting, you may still use the Shot of Steam® or Spray Mist features, as long as the Fabric Select Dial is set to wool, cotton, or linen. **IMPORTANT:** Water reservoir must be at least ¼ full of water.

### FILLING WATER RESERVOIR (*use tap water*)

1. Turn Steam Lever to ☼ (Dry) and Fabric Select Dial to Off. Unplug.
2. Lift the Water Fill Hole Cover. Use the easy-pour measuring cup to fill the water reservoir with tap water through the water fill hole. Do not fill water reservoir beyond maximum fill line.
3. Close the Water Fill Hole Cover completely after filling.

**WARNING:** To prevent the risk of burns, be careful when filling a hot iron with water. Hot metal parts, hot water and steam can cause injuries.

### STEAM IRONING

1. Follow the instructions for "Filling the Water Reservoir".
2. Fill Water Reservoir and plug the cord into a 120-Volt AC outlet.
3. Turn Steam Lever to desired steam setting. **IMPORTANT:** Only use Steam setting and/or Shot of Steam® feature with Wool, Cotton or Linen fabric settings.

(below the collar line), the other shoulder and the remainder of the front.

- Iron sleeves and cuffs, working down from the underarm seams. To remove creases, shift the double layer of sleeve fabric and iron out.
- Iron body of garment, from half of the front around the back, then second half of front. If your shirt does not open, slip over end of ironing board and iron front and back in turn.

#### IRONING PANTS

- Begin with the waistband and inseam area, then pockets and cuffs.
- Pull waistband on pointy end of the board, as if you're "dressing" the ironing board. Iron upper-front part of the pants, including the waistband.
- Place pants parallel to ironing board lengthwise so both legs are facing the same direction. Iron each leg by moving the iron back and forth along the pant leg.
- Take cuff of the leg and bring it over towards the waistband to iron the inner part of the leg. Repeat these 2 steps for the second leg.

### TROUBLE SHOOTING

PROBLEM	CAUSE/SOLUTION
"Power" indicator light is blinking and fabric setting light is off	<ul style="list-style-type: none"><li>• The red light blinks and beeps 6 times to indicate that the iron auto-off function has been activated.</li><li>• To stop blinking and reset, move the iron back and forth and allow to re-heat until the indicator light turns solid blue.</li></ul>
Iron is not heating	<ul style="list-style-type: none"><li>• Ensure the iron is on and the light below fabric setting is illuminated.</li><li>• Verify unit is plugged in.</li><li>• Adjust fabric selection to the correct setting for your garments.</li></ul>
Iron will not steam	<ul style="list-style-type: none"><li>• <b>Ensure water tank level is at least ¼ full.</b></li><li>• Ensure steam lever is switched on.</li><li>• Press Shot of Steam® button several times to prime.</li></ul>
Iron is leaking	<ul style="list-style-type: none"><li>• Only fill with water to the MAX level.</li><li>• Allow to heat for at least 2 minutes before use, and wait until the indicator light "Ready" has turned solid blue to indicate that it is ready.</li><li>• Shot of Steam® has been pressed too frequently. Only use Shot of Steam® in 3 second intervals or less.</li><li>• Steam Setting and/or Shot of Steam® used with incorrect fabric setting. <b>Only use with Wool, Cotton or Linen fabric settings.</b></li><li>• Empty water tank after each use and turn steam lever off.</li></ul>
Iron leaves spots/flakes on clothing	<ul style="list-style-type: none"><li>• <b>Empty water tank completely after each use.</b></li><li>• Clean soleplate when cool with a wet, damp cloth.</li><li>• Use self-cleaning feature once a month.</li><li>• Refer to the Anti-Calcium System section.</li><li>• Ensure water cup used to fill the iron is clean.</li></ul>
Wrinkles are not sufficiently removed	<ul style="list-style-type: none"><li>• Check that the iron is set to the correct fabric setting.</li><li>• Use Shot of Steam® or Spray Mist features to help remove stubborn wrinkles.</li></ul>
Fabrics are getting an unwanted "shine"	<ul style="list-style-type: none"><li>• Use an ironing cloth or a 100% white cotton fabric and place it between the garment being ironed and the iron to prevent "shine".</li></ul>

### STEAM IRONING (*continued*)

4. Press Fabric Select Button to select desired fabric setting. Allow iron to heat until the light under selected fabric setting turns solid blue. While iron is heating, make sure it is sitting on a stable, protected surface.

**IMPORTANT:** When not ironing, always set the Steam Lever to ☼ (Dry) and the Fabric Select Dial to OFF.

### SPECIAL FEATURES

**SPRAY MIST FEATURE** is a powerful water spray mist that dampens the fabric to aid in removing wrinkles from heavy fabrics and for setting creases.

TO USE: Press the Spray Mist Trigger firmly.

**SHOT OF STEAM® FEATURE** provides an extra burst of steam for deep penetration of stubborn wrinkles. You can use this feature while Dry or Steam ironing as long as the Fabric Select Dial is set to wool, cotton, or linen. **IMPORTANT:** The water reservoir must be at least ¼ full of water.

TO USE: Place the iron on top of the wrinkle and press the Shot of Steam® button each time you would like an extra burst of steam. The Shot of Steam® feature may be used continuously in approximately 3-second intervals.

**VERTICAL SHOT OF STEAM® FEATURE** allows iron to function vertically as a garment steamer.

**TIP:** When using vertical steam, hang clothing on a hanger for best results. Hanging curtains and drapes may also be steamed.

#### TO USE:

1. Ensure that the iron is heated up and the Ready indicator light has turned solid blue.
2. Hold iron vertically near, but not touching the fabric you want to steam. Pull the fabric tight.
3. Press Shot of Steam® button in 3-second intervals as you move iron over wrinkles.

**WARNING:** To prevent burns, keep hands away from the area being steamed.

**WARNING:** DO NOT steam or iron garments while wearing them; this may result in injuries.

### 3-WAY MOTION SMART AUTO-OFF FEATURE

Turns iron off if left in one position too long to avoid accidents.

#### IF YOU LEAVE IRON ON:

- If auto-off activates the unit will beep and the red light will blink until reset.
- Horizontally without moving it, or accidentally tip the iron over, it will automatically stop heating after 30 seconds.
- Vertically (on its heel rest) without moving it, the iron will automatically turn off after 8 minutes.

**TO RESET:** Move iron back and forth and reheat until the "Ready" indicator light turns solid blue.

### CARING FOR YOUR IRON AFTER USE

**TURNING OFF IRON:** Turn Steam Lever to ☼ (Dry) and Fabric Select Dial to Off. Unplug.

**WARNING:** NEVER yank power cord when unplugging iron. This can damage the cord.

**IMPORTANT:** Empty water reservoir completely after each use.

### STORING YOUR IRON

1. Turn off iron, unplug and allow to cool.
2. **IMPORTANT:** Empty water reservoir after each use for a longer iron life.
3. Loosely loop the power cord around the heel rest and store the iron on its heel rest. **IMPORTANT:** Wrapping the cord around the iron too tightly can damage the cord.

### 3 YEAR LIMITED WARRANTY AND LIFETIME LIMITED SOLEPLATE WARRANTY

This device has a limited warranty of 3 year from the original date of purchase against workmanship and defects in material. If under normal use, your product fails to operate, please contact our customer service department at info@sunbeamhome.com. A refund or replacement will be provided to you with proof of purchase. Star Elite Inc. may deny claims of damage caused by misuse or modifications of this product.

Printed in China

www.sunbeamhome.com

(8:30 am - 5:00 pm P.S.T.) Monday-Friday

or 1-877-383-6399

Questions? info@stareliteinc.com

SE050-120622

Distributed by Star Elite Inc., Montreal, Canada H3B 3X9.

used under license.

Sunbeam® and Shot of Steam® are registered trademarks of Sunbeam Products, Inc.

© 2022 Sunbeam Products, Inc. All rights reserved.

## MAINTAINING YOUR IRON

**USING SELF-CLEAN FEATURE:** Use the Self-Clean feature once a month to maintain optimal iron performance.

1. Turn off and unplug iron.
2. Move Steam Lever back and forth to remove debris and minerals from Steam Valve. This keeps water flowing into the steam chamber.
3. Fill water reservoir with tap water to MAX line.
4. Plug in iron, press Fabric Select Button to select Linen setting and heat until the indicator light turns solid blue.
5. Turn off and unplug iron. Holding iron over a sink in a horizontal position, press Self-Clean Button and hold. Water will begin dripping from the steam vents. Slowly rock iron side to side and front to back for 30 seconds. Dip nose of the iron slightly below the rear to circulate water. Release Self-Clean Button after one minute.
6. Open fill cap and empty remaining water. Carefully dry soleplate with a towel.
7. Plug in iron and set Fabric setting to Linen and Heat for 2 minutes to dry out completely. Set Fabric Select Dial to Off, unplug the iron, and allow to cool.

This appliance has no user serviceable parts. Any servicing beyond that described in the Cleaning Section should be performed by an Authorized Service Representative only. See warranty available online.

**CLEANING SOLEPLATE:** Clean soleplate after every 30 uses, or more frequently if starch is used or build-up starts to accumulate. Before cleaning, ensure iron is unplugged and cool.

**WARNING:** To avoid the risk of electric shock, do not immerse the iron in water or other liquids.

**NOTE:** Do not use abrasive cleansers or scouring pads to clean the soleplate. This will damage the finish.

Type of Debris/Build-Up	Cleaning Recommendation
Light Dirt	Use a cotton cloth or terrycloth towel to wipe the soleplate with warm soapy water.
Hard Water Deposits	Use a cotton cloth or terrycloth towel to wipe the soleplate with a 50/50 vinegar/water mixture.

## ANTI-CALCIUM SYSTEM

Anti-calcium is a permanent system located inside the water reservoir to eliminate impurities.

**TO PROLONG EFFICIENCY, FOLLOW THESE STEPS ONCE A MONTH OR AFTER EVERY 30 Uses:**

1. Turn off iron.
2. Add 1 teaspoon of salt to ¼ cup water and fill water reservoir with this solution.
3. Leave solution in water reservoir for 15 minutes, shake occasionally, and then empty through the fill hole.
4. Fill water reservoir again with salt water solution, shake and empty after 15 minutes.
5. Fill water reservoir with fresh water to rinse and empty.

## IRONING TIPS

- Before ironing, check the garment label and follow manufacturer's instructions. If no instructions, start with a low-heat setting and test by ironing a small area, and gradually increase heat.
- Sort garments by fabric type. Iron articles requiring a low-temperature setting and gradually work up the temperature range.
- When changing from a high-temperature setting to a lower one, allow 5 minutes for change.
- When steam ironing, use long, slow passes over the fabric to allow the steam to penetrate the fabric and the heat of the soleplate to dry the moisture.
- Iron linen garments inside out to prevent shine. An ironing cloth or cotton fabric can be used to reduce shine.
- If the garment is lined, use a low heat setting.
- Ensure zippers are closed and flap is flat. Iron over the flap, holding the garment taut.
- Spray starch makes the job easier.

### IRONING TIPS (*continued*)

#### IRONING SHIRTS

- Begin with the collar and work toward the middle from the outer edges. Iron lengthwise, not in circles.
- Lay shoulder over narrow edge of the board and iron one side of the front. Then iron the shoulder, across the back

PROFESSIONAL  
*Sunbeam*

*Sunbeam*  
PROFESSIONAL  
Digital Retractable Iron



**MODEL: 32610015**  
**ITEM: 12040**  
**Instruction Manual**

SAVE THESE INSTRUCTIONS

www.sunbeamhome.com