



PRO2.4D
DYNAMIC LIMITER
RMS + PEAK
DIGITAL AUDIO PROCESSOR

!

- 01 • Term of Warranty
 - Technical assistance
- 02 • Introduction
 - Safety requirements
 - Key recommendations
 - Safety
- 03 • Processor Overview
 - Screens & basic operation
- 04 • Output selection keys
 - Menu & parameters navigation
- 05 • Menu structures & description
 - Audio menu
 - Input/output routing
- 06 • Band equalizer
 - Crossover
- 07 • Delay
 - How to set the alignment parameter value
- 08 • Phase
 - Limiter
 - Limiter in RMS function
 - Limiter parameters
- 09 • Limiter in PEAK function
 - Limiter parameters:
 - Eq. parameter. output
- 10 • Audio generator
 - Language
 - Save Config.
- 11 • Load config.
 - Password / lock
 - Presets EQ
 - Text Message
- 12 • Connecting processor inputs & outputs
- 13 • Technical Features

TARAMPS, located on Julio Budisk highway, SN, KM 30 – Alfredo Marcondes, SP - Brazil, ZIP CODE 19180-000, warrants this product against any defects on terms of project, making, assembling, and/or with solidarity, due to project vices which cause it improper or inadequate to its original use within 12 months from the date of purchase. In case of defect during the warranty period, TARAMPS responsibility is limited to the repairing or replacement of the device of its own making.

This warranty excludes:

- Damaged products by improper installation, water infiltration, violation by unauthorized individuals;
- Tamper or torn warranty seal;
- Cases in which the product is not used in adequate conditions;
- Defects caused by accessories, modifications or features attached to the product;
- The product with damage from falling, bumps or nature related problems (flooding, lightning, etc);
- Warranty card is not properly filled or torn;
- Costs involving uninstallation, reinstallation of equipment as well the shipment to the factory;
- Damage of any kind, due to problems in the product, as well as losses caused by discontinued use of the product.

For international support, check on our website:

www.taramps.com.br/en/rede-de-assistencias-tecnicas or contact direct the factory support:

Phones: +55 18 3266-4050 / +55 18 99749-3391

E-mail: service@taramps.com.br

Read this manual before installing the product. In case of questions contact our technical support:

+55 (18) 3266-4050 or **www.taramps.com.br**.



At the end of its lifespan, this product must not be disposed of in household waste. Look for an electronic equipment collection or recycling center for proper disposal.

Declaration of Conformity	
CE	TARAMPS ELECTRONICS LTDA Alfredo Marcondes - SP Brazil
Hereby, Taramps Electronics Ltda declares that the product PRO 2.4D complies with the Directive 2014/30/EU, according with the following harmonized standard:	
-EN 50498:2010	<i>Electromagnetic compatibility (EMC) - Product family standard for aftermarket electronic equipment in vehicles</i>
The full text of the EU Declaration of Conformity is available at the Product Page on Internet.	

To ensure proper use, please read through this manual before using the processor. It is specially important that you know the **CAUTIONS** contained here.

- The installation of this product must be done by a qualified professional.
- Use the correct tools for installing this product.
- This product is for use with 12V batteries. Always check the voltage before installing.
- This product must be installed in a firm location and away from heat sources.
- Never install the product in places exposed to dust, humidity and water. Pay attention to install it far from fuel tank, fuel lines, heat sources and other parts of vehicle.
- Be sure to install protection fuse or a circuit braker near to battery. Follow the ampere rating as indicated here in this manual. Use of improper fuse or circuit breaker could result in overheat, smoke, damage to product, injury or burns.
- Avoid running wires over or through sharp edges. Use rubber or plastic grommets to protect any wires routed through car's body.
- Automotive sound systems may produce high sound pressure levels. Avoid continuous exposure to levels over 85dB to prevent permanent hearing loss.

The wire gauge for power supply connections is 1,5mm² (15 AWG) for positive and negative wires, and 0,50mm² (20 AWG) for remote signal wire.

For protection against overload, install a fuse on positive wire, close to battery terminal (1A). See page 12.

- 1 - Power supply negative: Connect to negative pole of battery.
- 2 - Remote signal input: Connect to remote signal output from head unit.
- 3 - Remote ouput: For connection in amplifiers
- 4 - Powe supply positive: Connect to positive pole (12V) of battery.



As you read this manual, pay attention to the safety symbols.

CAUTION

This symbol with **“CAUTION”** is intended to alert the user to the presence of important instructions. Failure to heed the instructions will result in risk of injury to user or product damage.



Taramps reserves the right to modify the contents of this document at any time without prior notice and does not have the obligation to apply the changes in units which were previously produced.

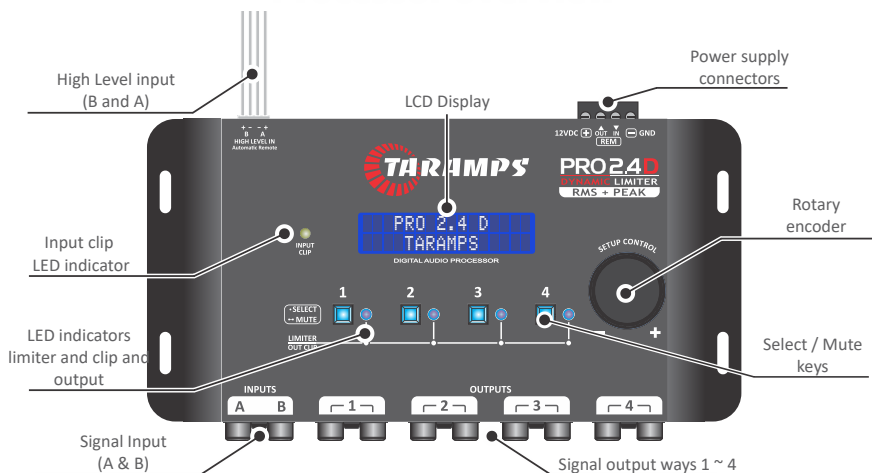

RCA signals input: Input for low level / high impedance (RCA) signals.

WIRE High Level Input: Input for high level / low impedance signals (from the speaker output of the players or multimedia center).

It features function of automatic turn-on by the input signal, so it eliminates the use of the REMOTE IN wire from the power connector when using this input.

Note: The system is designed for use in virtually all multimedia head units on the market. However, on some head units, you may not get the trigger effect due to the type of audio output circuit. In this case, use the REMOTE wire for triggering it normally.

Input clip indicator LED: It shows that the signal is reaching the maximum limit of the processor input, which causes signal distortion. If it comes on, reduce the volume of the signal source and readjust the system gains accordingly.

Limiter / clip LEDs: They have a dual function: They indicate that the signal from that output has reached the maximum level (when the limiter is off) or the actuation of the limiter (when the signal reaches the threshold defined in the limiter).

Power connector: See page 12.



INITIAL SETUP: When turned on for the first time, the processor waits for the language to be set. Choose the desired language and confirm with a quick touch in the center of the encoder.

Turning the encoder knob (clockwise or counterclockwise), adjusts the master volume (Input volume).



Quick touch (Click) on the key of each output(1 to 4) It performs an adjustment of the individual gain in each output.

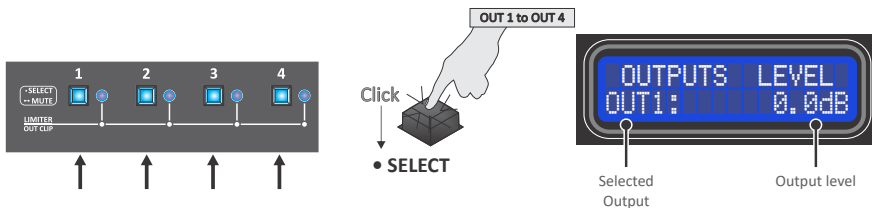

Individual mute: Press the output key (1 to 4) for 1 second until the key goes out. To unmute individual sound, press it again for 1 second.

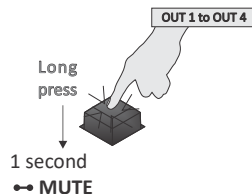

Quick click on the center of the encoder, to access the MAIN MENU and its functions. Long touch (1 second) in the center of the encoder returns to the previous menu, until returning to the main screen.

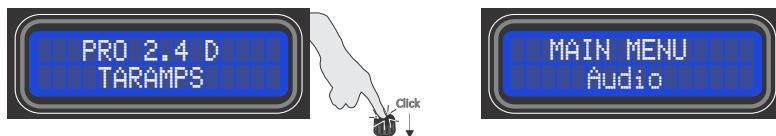

Use the encoder, turning left (decrement) or right (increment). Menu selection, option or parameter change can be done by pressing the center of the encoder.

Note: In any of the audio adjustment screens, the hotkeys for channels 1 to 4 allow you to check and adjust the parameters of each channel without leaving the desired option

Tip: To fine-tune a parameter or increment/decrement the number after the decimal point, rotate the encoder slowly. E.g., in the signal level (dB) adjustments, the increment will be 0.1dB when turning the encoder slowly, and 1dB when turning it more continuously and quickly.



PT-BR	ENG	ESP
MENU PRINCIPAL :	MAIN MENU :	MENU PRINCIPAL :
1-Áudio	1-Audio	1-Audio
2-Gerador De Áudio	2-Audio Generator	2-Generador Audio
3-Idioma	3-Language	3-Idioma
4-Salva Config.	4-Save Config	4-Guardar Config
5-Carrega Config	5-Load Config	5-Cargar Config
6-Senha / Bloqueio	6-Password / Lock	6-Contraseña / Bloqueo
7-Presets EQ	7-EQ Presets	7-Preset EQ
8-Mensagem / Texto	8-Text / Message	8-Mensaje de Texto

Press the encoder button (center – long press) to back to Main Screen.

1- Audio menu: Adjusts and controls related to audio processing:

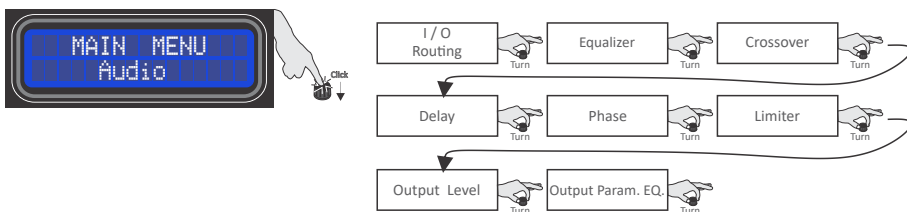

I/O Routing: Defines the internal connections between outputs and inputs. Available options: A, B or A+B (sum of the two inputs).

E.g.: setting the OUT 1 output to A, its signal will come from input A.



Use the OUTx keys to select the desired way

Turn the rotary encoder to select the input

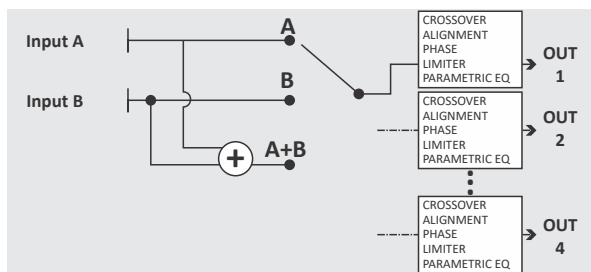

-Band equalizer: It has 5 filters of equalization, with attenuation/boost of up to 12dB, adjustable Q factor, 2 octaves, but center frequencies which can be changed up to 2/3 octave. Acts simultaneously on inputs A and B.

The Pro 2.4D has 12 preset equalization curves, selectable in MAIN MENU > Presets EQ.

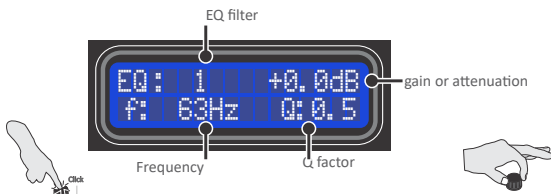
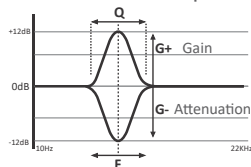

Click on the encoder center to select the desired parameter

Rotate the encoder to change the selected parameter

	MINIMUM	STANDARD	MAXIMUM
EQ 1	40 Hz	63 Hz	100 Hz
EQ 2	160 Hz	250 Hz	400 Hz
EQ 3	630 Hz	1.000 Hz	1.600 Hz
EQ 4	2500 Hz	4.000 Hz	6.300 Hz
EQ 5	10.000 Hz	16.000 Hz	20.000 Hz

-Crossover: Set the high pass (HPF) and low pass (LPF) filters of selected output way. The cutoff frequencies could be set from 10Hz to 22KHz, and are available some kinds of filters (Butterworth, Bessel, Linkwitz Riley) in different slopes (-6, -12, -18, -24, -30, -36, -42 e -48dB/Octave).

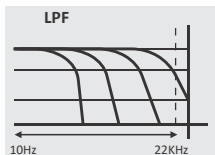
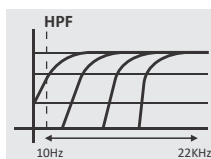
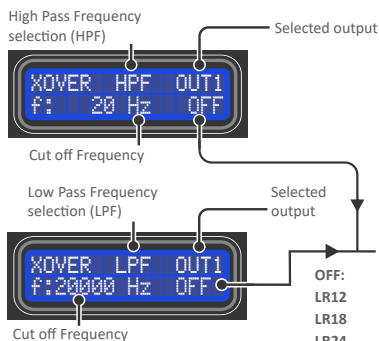

- FILTER TYPE / ATTENUATION:**
- OFF: Off
 - LR12 Linkwitz - Riley c/ -12dB/octave
 - LR18 Linkwitz - Riley c/ -18dB/octave
 - LR24 Linkwitz - Riley c/ -24dB/octave
 - LR30 Linkwitz - Riley c/ -30dB/octave
 - LR32 Linkwitz - Riley c/ -32dB/octave
 - LR36 Linkwitz - Riley c/ -36dB/octave
 - LR48 Linkwitz - Riley c/ -48dB/octave
 - BT6 Butterworth c/ -6dB/octave
 - BT12 Butterworth c/ -12dB/octave
 - BT18 Butterworth c/ -18dB/octave
 - BT24 Butterworth c/ -24dB/octave
 - BT30 Butterworth c/ -30dB/octave
 - BT36 Butterworth c/ -36dB/octave
 - BT42 Butterworth c/ -42dB/octave
 - BT48 Butterworth c/ -48dB/octave

Delay: Set the delay to be applied to audio signal, for systems alignment. The position of transducer's voice coil should be taken in account in order to set the optimal delay value. **ENGLISH**

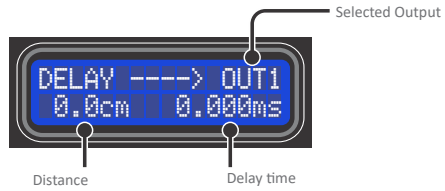

Rotate the rotary encoder to set the delay amount to be applied.

The voice coils of each transducers isn't aligned inside the acoustic box, so there is some delay that can degrade the perfect audio playing. The **Delay** feature apply different delay amount for each output way, in order to get the perfect audio alignment.

- 1 Set the reference coil (*) farthest from the box panel (in our example, the reference was the center of the horn coil)
- 2 Measure the other channels and find the measure **A** . Set the closest measurement (in cm) for each channel.
- 3 Repeat the procedure for the other channels (the channel selection can be done through the keys of each channel).

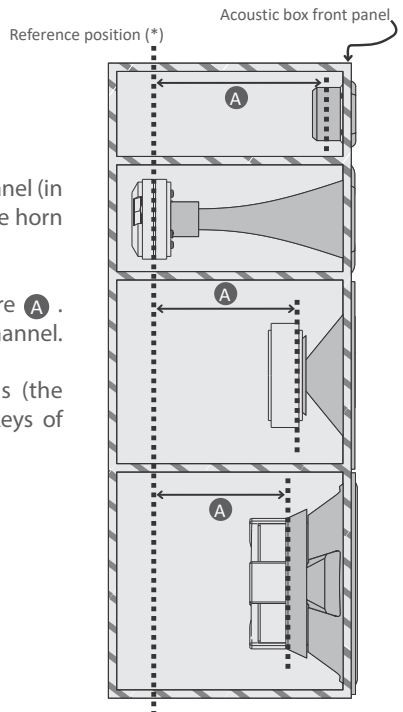

-Phase: Allows inverting the phase of the channel output signal, selecting option [180]. Select the channel using the OUT1 to OUT4 selection keys and select the desired phase by turning the encoder.

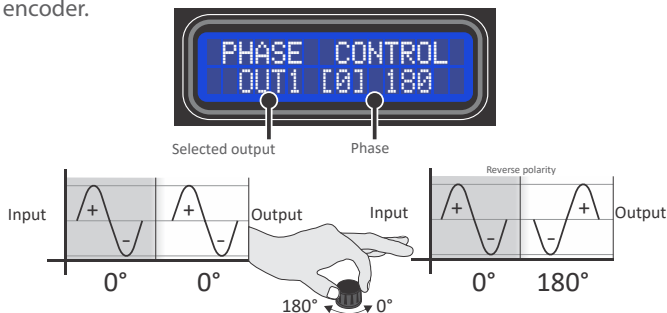

-Limiter: Acts as a limiter for the maximum signal level of the processor output, so as not to exceed the power limit supported for each system transducer.

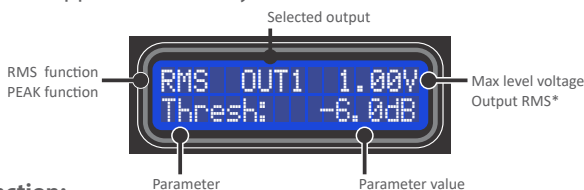

Limiter in RMS function:

Limiter that acts with reference to the RMS value of the audio signal, prevents overheating of the speakers due to excessive power.

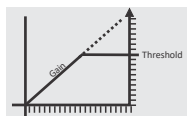

Limiter parameters:

Modes: **MANUAL** = Manual Attack, Hold and Release adjustment; **AUTO**: Sets the Attack, Hold and Release parameters automatically, according to the channel frequency cutoff (HPF).

Threshold – Point when the limiter begins to act (indicated by the RED LED on each lane turning on). To turn off the limiter, turn the encoder clockwise until [OFF] appears in the threshold value.

Attack, or Attack time – Time needed to limiter reduce the gain after the signal reaches the threshold.

Hold – Time that the limiter keeps the signal attenuated even after its level drops below the threshold.

Release, or Release time – Time needed to limiter return to the original gain after the signal drops below the threshold.

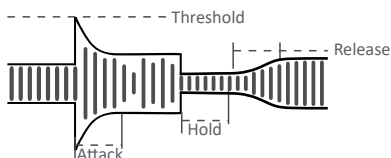

* According to Threshold selected. The accuracy of this measurement depends on the signal frequency as a function of the Attack time. At low frequencies, very fast attack times can affect measurement accuracy.

Limiter in PEAK function:

Limiter that acts with reference to the PICO value of the audio signal, prevents mechanical damage and overheating of the speakers due to excessive displacement.

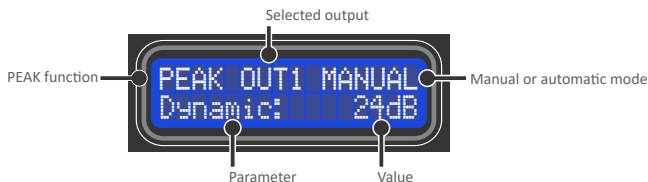

Limiter parameters:

Modes: **MANUAL** = Manual Release adjustment; **AUTO**: Sets the Release parameter automatically, according to the channel frequency cutoff (HPF).

Dynamic – Point when the limiter acts (indicated by the lighting of the RED LED on each channel) with reference to the peak value of the signal in relation to the threshold defined in the RMS limiter (Music Dynamics).

Hold – Time that the limiter keeps the signal attenuated even after its level drops below the threshold (Dynamic).

Release, or Release time – Time needed to for the limiter to return to the original gain after the signal drops below the threshold.

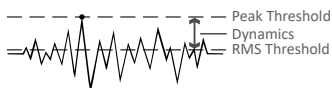

Examples:

Signal type	Dynamic
Sinusoidal	3 dB
Pink noise	6 ~ 12 dB
Heavy rock	10 ~ 12 dB
Rock / Pop	12 ~ 15 dB
Jazz	15 ~ 20 dB
Vocal	15 dB
Orchestra	10 ~ 24 dB
Bass	6 dB

-Output level: Defines the level of each output channel, allowing to apply from -45dB attenuation up to +15dB gain, regardless the main volume. Select the output channel using the selection keys (1 to 4), adjust the gain level by rotating the encoder.



Note: This function has a shortcut: simply pressing the corresponding output key when in the main screen.

-Output parametric EQ: EQ with 1 band and adjustable parameters for:

G = Filter gain/attenuation (-12dB to +12dB)

F = Filter central frequency, adjustable from 10Hz to 22KHz

Q = Filter width adjustment from 0.4 (widest) to 10.0 (narrowest)

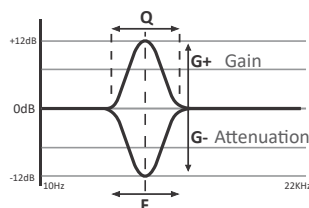



-) **Audio Generator:** Sine wave generator, with frequency and variable amplitude. With 4 modes:

- **Fixed Frequency:** Sine generator with frequency (10Hz to 22KHz) and amplitude (-60dB to 0dB) adjustments. Note that when activating the generator, the signal is sent to all outputs and it is possible to adjust the other functions and parameters in real time, since the generator remains active and defined as a signal source when in the ON position, even when accessing another function..

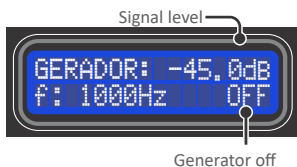

Generator off

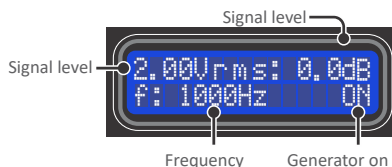

Frequency Generator on

*The voltage level shown is informative and may differ depending on processing settings (Equalization, cuts, limiter, etc...).

- **Sweep (Slow / Medium / Fast):** It performs a signal sweep, with the initial and final frequency defined by the user, which remains in a continuous cycle (repeating) until the generator is turned OFF. There are 3 sweep speeds available.

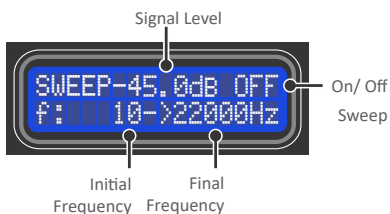

3-) **Language:** Choose the desired language (Portuguese, English or Spanish)



4-) **Save config:** Allows you to choose the memory location and assign a convenient name to these settings. Selecting which memory location, click on the encoder center to switch to the text. Rotate the encoder to select the desired letter, click on the center of the encoder to move to the next character. To erase, rotate the encoder until "<" + quick touch on the center of the encoder. To finish editing and save the memory name, place the cursor after the last character + long press on the center of the encoder and confirm "YES".

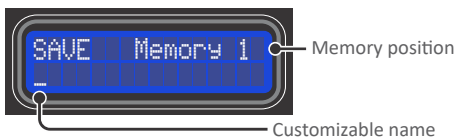



5-) Load config: Load a previously saved configuration or the factory default setting. Rotate the encoder to select the desired memory, click on the center of the encoder to select and then confirm. Important: when you select the FACTORY SETTINGS option, the previously saved settings will be lost.



6-) Password / lock: Allows you to lock the processor using a password (the default password is 1234) or change the password to a personalized one, with 4 digits. NOTE: When locking the processor, a padlock icon will appear in the upper right corner of the screen. A password will be required to access the settings. To reset the processor to factory settings without accessing the menu (e.g. due to lost/forgotten password), just turn on the processor while keeping the keys of ways 1 and 2 and the center of the encoder pressed simultaneously. This will erase the contents of user settings memories and reset the product to initial setup.

7-) Presets EQ: The Pro 2.4D has 12 preset equalizer curves. Select the music style and press the encoder center to apply the equalization curve:

- FLAT
- LOUDNESS
- BASS BOOST
- MID-BASS BOOST
- TREBLE BOOST
- POWERFUL
- ELECTRONIC
- ROCK STYLE
- HIP-HOP STYLE
- POP MUSIC
- VOCAL
- COMPETITION

8-) Text message: Defines a text of up to 15 alphanumeric characters to be displayed as screen saver animation. Enable the function by selecting ON and with a quick touch on the center of the encoder, and go to text editing (blinking cursor). Rotate the encoder to select the desired letter, click the center of the encoder to move to the next character. To erase, turn the encoder until "<" + quick touch on the center of the encoder. To finish editing and save the text, place the cursor after the last character + long press in the center of the encoder. After about 3 seconds of no activity on the main screen, the text will be displayed as an animation on the screen.

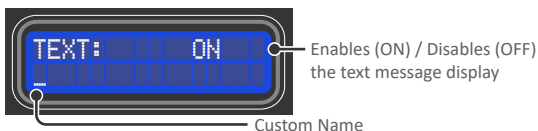

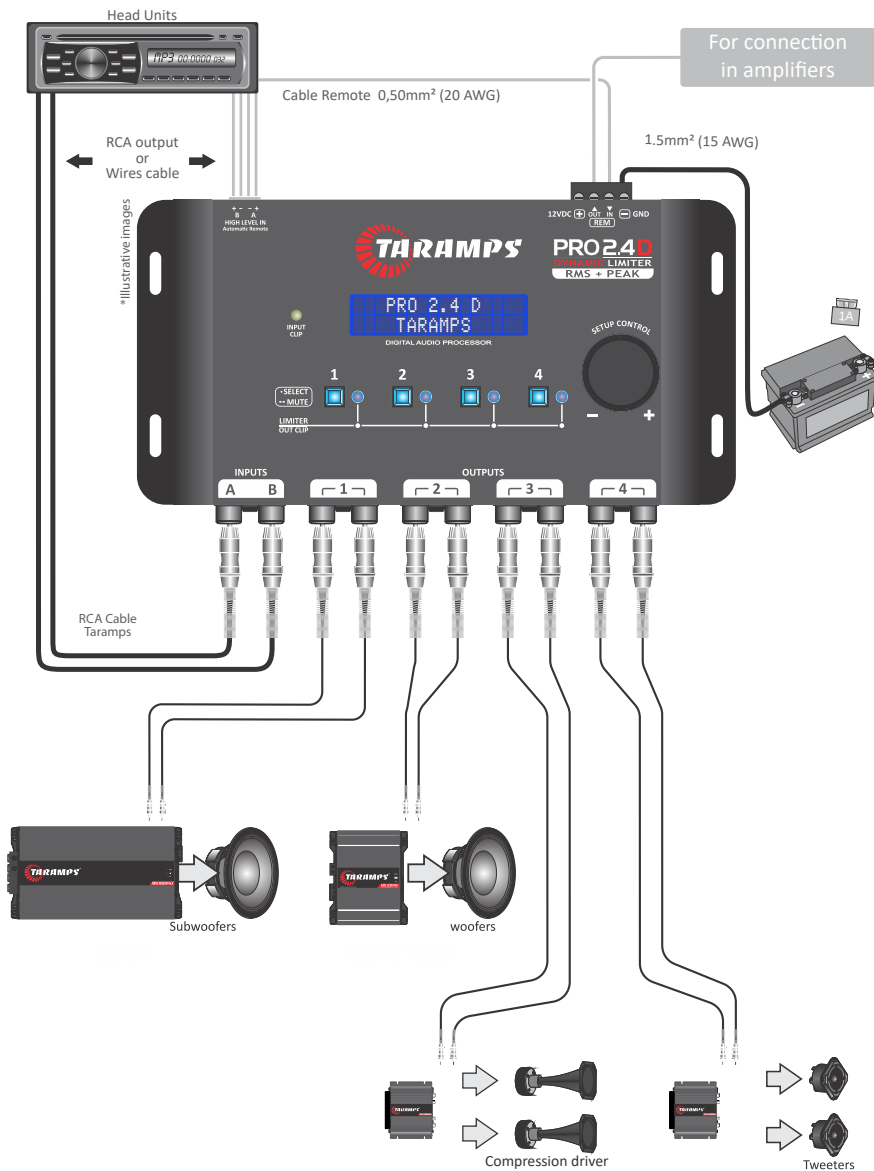

! CAUTION

Check power polarity and recommended gauge. it is recommended to install a 1 Ampere fuse on the positive supply terminal.

TARAMPS[®]



+55 18 3266-4050

Manufactured by:
TARAMPS ELECTRONICS LTDA
TAX ID: 11.273.485/0001-03
Highway: Julio Budisk, SN, KM 30
Alfredo Marcondes - SP
Made in Brazil
www.taramps.com.br