



## **CLASSIC 2.0l/CLASSIC 3.2l**

*Cuiseur Automatique • Automatic rice Cooker  
Automatische Rijstkoker • Cuoci riso Automatico  
Automatik-Reiskocher*

---

**MODE D'EMPLOI • INSTRUCTIONS FOR USE • GEBRUIKSAANWIJZING  
ISTRUZIONI D'USO • GEBRAUCHSANWEISUNG**

# CLASSIC 2.0I/CLASSIC 3.2I

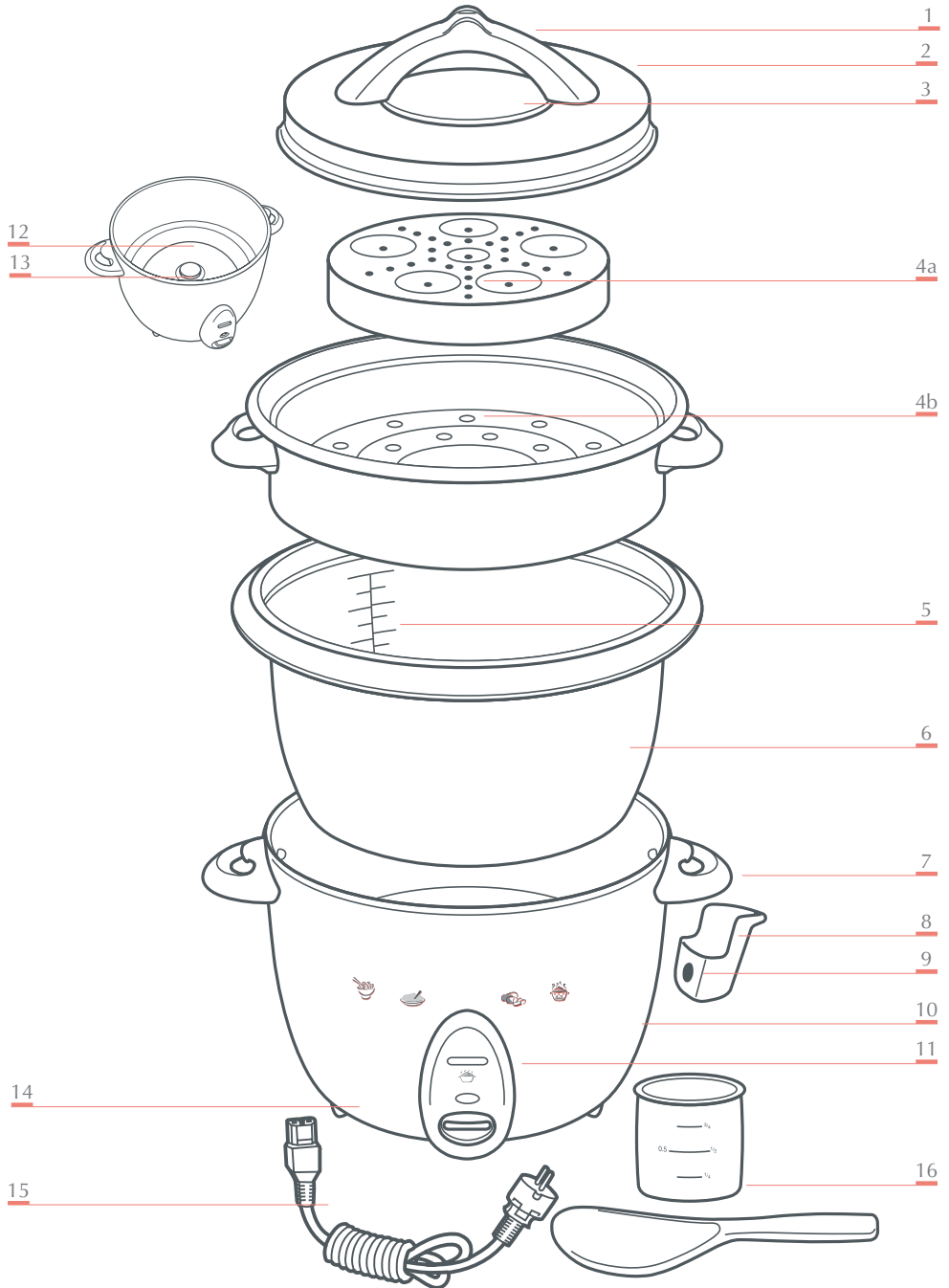

## Features

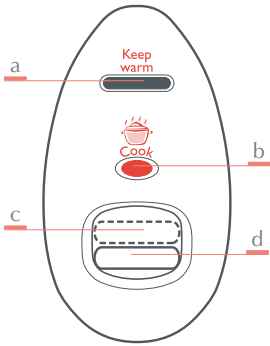

- 1 Lid handle with spoon holder**
- 2 Lid**
- 3 Glass viewing window**
- 4 Steam accessories**  
(depending on model)
  - a Steam plate** (model 2.0l)
  - b Steam bowl** (model 3.2l)
- 5 Water and rice graduation**
- 6 Removable non-stick bowl**
- 7 Carrying handle with lid holder**
- 8 Magnetized condensation collector**
- 9 Magnet**
- 10 Body of the appliance**
- 11 Control panel**
  - a keep warm indicator** (green)
  - b cooking indicator** (red)
  - c Keep warm button**  
(button at the top)
  - d Cooking button**  
(button at the bottom)
- 12 Heating plate**
- 13 Sensor**
- 14 Non-skid base**
- 15 Removable connecting cord**
- 16 Spoon and measuring cup**

## Safety reminders

- This appliance complies with current safety rules and conditions and with the following directives:
  - Electromagnetic Directive 89/336/EEC amended by Directive 93/68/EEC.
  - Low Voltage Directive 73/23/EEC amended by Directive 93/68/EEC.
- Check that the mains voltage matches the voltage indicated on your appliance (alternating current (AC) only).
- Due to the variety of standards in force, if you are to use your appliance in a country other than that in which it was bought, it is advisable to have it checked by an approved service centre.
- This appliance has been designed for domestic use only. Any professional or unsuitable use, or any usage not in accordance with the instructions does not comply with the manufacturers guarantee.
- Do not leave the appliance unattended when in operation.
- Keep out of the reach of children.
- Use a flat working surface and avoid splashing with water.
- Do not place the appliance near or on a source of heat.
- Never try to operate the appliance when the bowl is empty or without the bowl.
- Do not remove the bowl while the appliance is working.
- Do not put the appliance directly onto a flame or any other source of heat.
- The bowl and the heating plate should be in direct contact. Any item placed between these two elements could cause a failure.
- Do not put any food or water into the appliance until the bowl is in place.
- Observe the levels indicated in the recipes.
- When using an electric appliance that heats, high temperatures are reached which can cause burns. Do not touch the apparent metal parts.
- During cooking, the appliance gives out heat and steam. Do not touch or lean over where the steam escapes. Do not place a damp cloth over the outside lid.
- Do not immerse the body in water nor pour water into it only into the bowl.
- Do not allow the cord to hang.
- Always plug the appliance into an earthed socket.
- Do not pull on the cord to unplug it.
- Unplug the appliance should any fault occur after use or before each cleaning or care operation.
- Should any part of your appliance catch fire, do not attempt to put it out with water. Smother the flames with a damp cloth.
- Do not use the appliance if:
  - it or its removable connecting cord are faulty,
  - the appliance has been dropped and shows signs of deterioration or faulty working,In this case, the appliance should be sent to your nearest service centre because special tools are needed for any repairs.
- If the power lead is damaged, it must be replaced by the manufacturer, his After-Sales Service or a similarly qualified person to ensure danger-free use.

## Wiring instructions

### FOR UK ONLY

**WARNING: THIS APPLIANCE MUST BE EARTHED.**

**Important: the wires in this lead are coloured in accordance with the following codes:**

**Green and Yellow: Earth**

**Blue: Neutral**

**Brown: Live**

Connect the Green/Yellow wire to the terminal in the plug marked " E " (or by the

earth symbol) or coloured Green or coloured Green and Yellow. Connect the Brown wire to the terminal in the plug marked " L " or coloured Red. Connect the Blue wire to the terminal in the plug marked " N " or coloured Black. A 13 amp fuse should be fitted when the appliance is connected to a BS 1362 plug. Seek professional advice if you are unsure of the correct procedure for the above.

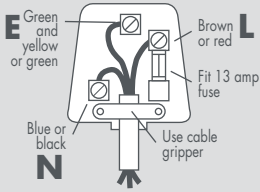

## Voltage

This appliance is designed to run on 230 - 240 volts only. Check that the mains supply corresponds to that shown on the rating plate of the appliance. If the appliance is to

be used in any country other than that of purchase, it should be checked by an approved Service Dealer. Standards can vary from country to country.

## About your factory fitted plug

### FOR UK ONLY

(supplied with certain models only)

The lead is already fitted with a plug incorporating a 13 amp fuse. If the plug does not fit your socket outlet, see next paragraph.

Should you need to replace the fuse in the plug supplied, a 13 amp approved BS 1362 fuse must be used.

**The fuse cover is an important part of the plug. Please ensure that it is always refitted. If you lose this cover please do not use the plug. You may contact TEFLAL for a replacement.**

If the plug supplied does not fit your socket outlet, it should be removed from the mains lead and disposed of safely. The flexible cord insulation should be stripped back as appropriate and a suitable alternative plug fitted. The replacement plug must be equipped with a 13 amp fuse.

**Important:** If the electrical cord of this appliance is damaged, it must only be replaced by an authorised Service Dealer. The safety of this appliance complies with the technical regulations and standards in force.

Model 2.0l

Model 3.2l



1



2

White Rice	Cup	Level of water	Pers.
300 g	2	2	2 - 4
600 g	4	4	4 - 8
900 g	6	6	6 - 12
1200 g	8	8	8 - 16
1500 g	10	10	10 - 20



3

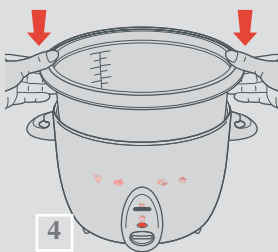

4

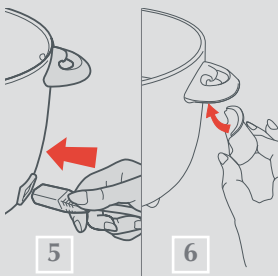

5

6

## PREPARATION

### Before using for the first time

**Read the instructions and follow them carefully.**

#### Unpack the appliance

- Take the rice cooker out of its packaging and unpack all the attachments.
- Remove the lid.

- Take out all the printed documents.
- Take out the removable bowl.
- Clean the lid and the bowl with a sponge and a little washing up liquid. Wipe the outside of the appliance with a damp cloth.
- Dry carefully.

### Measuring the ingredients - Maximum capacity of the bowl

The graduations on the inside of the bowl should only be used for cooking rice. They are given in litres and CUPS - **Fig. 1 et 2** (depending on model)

- The word CUP means a measuring cup (provided).
- 1 CUP = 150 level grams of rice (for 1-2 people depending on your appetite).

#### 1) For preparing rice

- Pour the rice into the cooker. Add water up to the corresponding mark (example: 4 cups of rice = water mark 4 - see table opposite).
- Note: the graduation in litres reminds you of the amount of water you have added.

- For 1 to 2 persons, pour in one measure of rice, then add one and half measures of water.

#### 2) For cooking other foods

- For other cooking the total volume is: Automatic Rice Cooker 2.0l: 2 litres that matches level 1.2 litres on the graduation - **Fig. 1**  
Automatic Rice Cooker 3.2l: 3.2 litres that matches level 1.8 litres on the graduation - **Fig. 2**

**Do not exceed the maximum indicated amounts (depending on model).**

### Preparation before cooking

#### For all uses

- Pour the right amount of water and the ingredients into the bowl according to the chosen recipe.
- Carefully wipe the outside of the bowl, especially the bottom. Check that there is no foreign matter under the bowl or on the heating plate - **Fig. 3**
- Place the bowl inside the appliance, making sure that it is properly in position - **Fig. 4**
- Slightly turn the bowl in both directions so as to ensure a good contact between the bottom of the bowl and the heating plate.

#### • When steaming (depending on model)

- Pour the right amount of water into the bowl according to the chosen recipe.  
**Steam plate:** place the steam plate on the bowl, with the with egg holder facing upwards.  
**Steam bowl:** place the steam bowl on the bowl. Put ingredients in.
- Put the lid on the appliance.
- Push the removable connecting cord completely in, then plug it into the mains socket - **Fig. 5**
- Do not switch on until all the previous steps have been completed.

#### Install the magnetic condensation collector - Fig. 6

- Insert the collector below the carrying handle (with the magnet on the appliance side).

## COOKING

**Starting the cooking**

- Press downwards on the control switch, the red cooking indicator alluminates showing that cooking has begun - **Fig. 7**

**Warning: if the bowl has not been placed in the appliance, cooking cannot begin.**

**Automatic keeping warm**

At the end of cooking, the Automatic Rice Cooker detects the total absorption of the water and automatically passes to the "keep warm" function. At that moment, the control switch comes up to its top position and the "keep warm" indicator lights up in green - **Fig. 8**

The food thus remains hot, ready to be served.

**End of cooking**

When you are ready to eat:

- Remove the lid. Warning: the escaping steam is very hot.
- Place the lid on the side handle, on the condensation collector side. The collector accumulates the condensation - **Fig. 9**
- Serve with the spoon provided with the appliance and put the lid back.

**A few tips for better results in cooking rice:**

- Measure the rice and wash it separately under running water. Place the rice in the bowl with the right quantity of water.
- Make sure that the rice is spread over the whole surface of the bowl to ensure even cooking.

- When cooking rice or steaming, the Automatic Rice Cooker will automatically determine the exact cooking time, depending on the quantity of water and the ingredients placed in the bowl.

The Automatic Rice Cooker remains in "keep warm" position for as long as the appliance is switched on.

**Manual starting**

- It is possible to start the keep warm function by lifting the control switch. This could be useful for example for heating cold food that is already cooked.

- **Warning:** the bowl is hot. Always use oven gloves to remove it.

- The food left in the Automatic Rice Cooker remains hot for a possible second helping.
- Take the removable connecting cord plug out of the mains socket.

- At the end of cooking time, when the "keep warm" function comes into operation, stir the rice and leave it in the Automatic Rice Cooker for a few minutes to obtain perfect results.

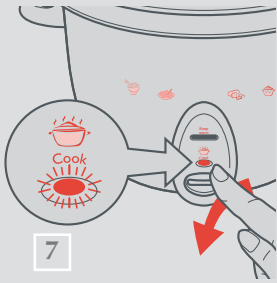

7

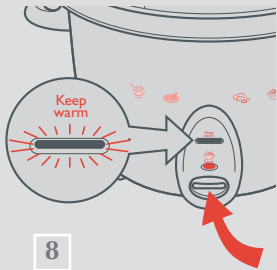

8

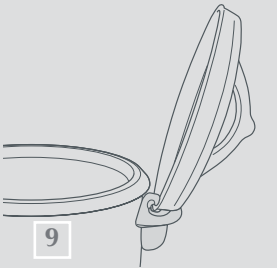

9

---

---

## CLEANING AND MAINTENANCE

---

---

The condensation collector should be emptied and cleaned after each use - Fig. 10



Cleaning the bowl, the lid and the steam accessories - Fig. 11

- Use hot water, washing up liquid and a sponge to clean the bowl and the lid. Scouring powders and metal sponges are not recommended.

- If food has stuck to the bottom, allow the bowl to soak for a while before washing it.
- Dry the bowl carefully.
- Do not immerse the appliance in water, nor pour water into it only into the bowl.

You can also wash the bowl, the lid and the steam accessories in a dish washer - Fig. 12

For the bowl, carefully follow the instructions below:

- When putting into the machine, be careful not to damage the inside coating on the dish washer racks.
- After being washed several times in the

dish washer and to renew the surface, it is recommended to wipe the whole of the inner surface of the bowl with a little oil.

- So as to keep the non stick quality for as long as possible, it is recommended not to cut food in it.
- Make sure you put the bowl back into the Automatic Rice Cooker.

**Important:**

The brown marks and scratches that may appear after many hours use are not a problem. We guarantee that the

non stick coating **COMPLIES WITH THE RULES** on materials suitable for contact with food.

**Taking care of the bowl**

- Use a plastic or wooden spoon and not a metal one so as to avoid damaging the bowl surface.
- To avoid any risk of corrosion, do not pour vinegar into the bowl.
- The colour of the bowl surface may

change after using for the first time or after longer use. This change in colour is due to the action of steam and water and does not have any effect on the use of the Automatic Rice Cooker, nor is it dangerous for your health. It is perfectly safe to continue using it.

**Cleaning and care of the other parts of the appliance**

- Clean the outside of the Automatic Rice Cooker and the cord with a damp cloth and wipe dry. Do not use aggressive or abrasive products.

- Do not use water to clean the inside of the appliance.
- Before putting the appliance away, wind the cord and put it in the bowl with the attachments. You can also clip the spoon on the lid handle - Fig. 13

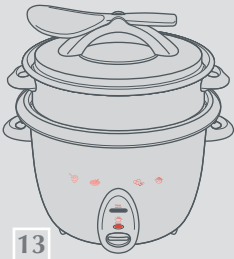
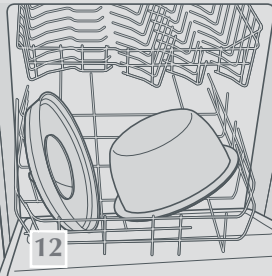

## After sales services

(For UK only)

In the unlikely event your appliance should fail within the first 28 days from the date of purchase, your retailer is authorised to exchange it. After 29 days from the date of purchase, for repairs and spares telephone your nearest TEFAL Service Centre on 0845 725 8588, calls charged at local rates. Alternatively you may post your faulty product for repair to the following address:

TEFAL Service Operations,  
PF Box 155, Birmingham B1 3DP.  
Tel: 0121 200 2740.

TEFAL Ireland,  
Gavin Electronics Ltd,  
83 Lower Camden Street,  
Dublin 2, Southern Ireland.  
Tel: 1 47 57109.

---

### Before posting

1. Enclose your name, address and details of the fault.
2. If you are returning under the guarantee, it must be accompanied by a till receipt as proof of date of purchase.
3. If it is outside the guarantee period, please advise our Service Centre of the maximum amount of money you wish to spend to make it operational again.
4. If returning a fryer, please empty the oil from the fryer and clean the inside before returning it.

The above details are in addition to a consumer's statutory rights and does not affect those rights in any way.

Replacement accessories and spare parts for your TEFAL appliance such as anti-scaling cassettes for irons, filters for deep fat fryers or gaskets for pressure cookers are available from TEFAL stockists or your local Service Centre.

Alternatively you can obtain them by mail order from TEFAL Direct on: 01702 290 089.

When ordering spares you will need to know the model number of your appliance.

---

### Customer Relations

For product information or any other queries please telephone:  
0800 616 413

## TABLE OF CORRESPONDING MEASURES TO THE CUP

Measuring cup	Liquid	Rice
Full	165 ml	150 g
3/4	125 ml	115 g
1/2	90 ml	80 g
1/4	45 ml	35 g

### HOW TO PREPARE SEVERAL DIFFERENT FOODS AT THE SAME TIME (models 3.2 L)

You can use the steam vent from the rice cooker to cook another type of food at the same time in the steam bowl. For example, you could choose to cook the rice at the bottom and the fish at the top. For the quantities of water to put into the main bowl, refer to the indications given in the rice recipes, except for cooking brussel sprouts, potatoes and broccoli. In this case, you must add 50 ml of water.

*Suggestions for combining dishes:*

- rice "à la Greque" with sausages and cumin,
- rice "à la Turque" with scallops cooked in tinfoil,
- pilau rice with haddock and spinach,
- saffron rice with steamed fillet of turbot,
- plain rice with crunchy broccoli,
- pilau rice with honey spiced apples or pears.

### EXAMPLES

#### **Rice "à la Greque" with sausages and cumin**

Prepare the rice à la greque in the bowl (see recipe in the booklet), place the 8 sausages in the steam bowl and prick with a fork. Sprinkle with cumins Close the lid. Switch on. The appliance will automatically switch over to keep warm after 16 minutes cooking.

#### **Pilau rice with honey spiced apples or pears.**



Prepare the pilau rice in the bowl (see recipe in the booklet). Place the 4 peeled apples or pears in the steam bowl. Brush over with the honey spices (mix a tablespoon of honey with a teaspoonful of powdered cinnamon, 3 ground peppercorns and a clove). Close the lid and switch on. The appliance will automatically switch over to keep warm after 16 minutes cooking.

## COOKING VARIOUS TYPES OF RICE

Type of rice	Cup of rice	Weight of rice	Volume of water	Level in the bowl
White rice (Surinam, Basmati, Thai...)	4	600 g	800 ml	4
Round white rice (often a sticky rice)	4	600 g	800 ml	4
Whole rice	4	600 g	900 ml	4.5
Wild rice	4	400 g	600 ml	3.5
Pre-cooked risotto	4	600 g	800 ml	4

*Wash the rice before cooking except for pre-cooked risotto.*

*We should like to point out that the given cooking times are only approximate and that they vary depending on quantities and personal taste.*

*In some of the recipes, a pictogram shows you the amounts and the cooking times which go with your Rice Cooker model,  or . For the other recipes, the amounts and cooking times are the same for both models.*



### PLAIN RICE

(for 4)

**Preparation:** 5 mins

**Cooking time:**  16 mins  22 mins

**Ingredients:** 2 measures or 300 g long grain rice, 400 ml water, salt.

*Rinse the rice under running water. Place the rice in the bowl. Season with salt. Close the lid and switch on. The appliance will automatically switch over to keep warm after  16 mins  22 mins cooking.*

Average energy value for 1 serving: 260 kcal. - 1075 kJ



### RICE A LA GREQUE

(for 4)

**Preparation:** 10 mins

**Cooking time:**  16 mins  22 mins

**Ingredients:** 2 measures or 300 g long grain rice, 50 ml olive oil, 1 chopped onions, 50 g sausage meat, 100 g frozen peas, 50 g red peppers, 400 ml chicken stock, salt, pepper.

*Rinse the rice under running water. Cut the red pepper into small pieces. Place the olive oil, chopped onion, rice and sausage meat in the bowl. Stir well. Add the chicken stock and stir in the frozen peas and red pepper. Season. Close the lid and switch on. The appliance will automatically switch over to keep warm after  16 mins  22 mins cooking.*

Average energy value for 1 serving: 800 kcal. - 3330 kJ

## PILAU RICE

(for 4)

**Preparation:** 10 mins

**Cooking time:** 16 mins 22 mins

**Ingredients:** 2 measures or 300 g rice (Basmati or Thai), 400 ml chicken stock, 1 finely chopped onion, 50 g butter, salt.

*Rinse the rice under running water. Place the butter, chopped onion, rice and chicken stock in the bowl. Season with salt. Stir well. Close the lid and switch on. The appliance will automatically switch over to keep warm after 16 mins 22 mins cooking.*

Average energy value for 1 serving: 806 kcal. - 3350 kJ

## RISOTTO MILANESE

(for 4)

**Preparation:** 20 mins

**Cooking time:** 16 mins 22 mins

**Ingredients:** 2 measures or 300 g long grain rice, 50 ml olive oil, 1 chopped onion, 100 g ham, 100 g mushrooms, 400 ml chicken stock, salt, pepper, 250 ml tomato sauce, parmesan cheese.

*Rinse the rice under running water. Cut the ham and mushrooms into small pieces. Place the olive oil, chopped onion, mushrooms, ham and rice in the bowl. Stir well. Add the chicken stock and season. Close the lid and switch on. The appliance will automatically switch over to keep warm after 16 mins 22 mins cooking. Serve with tomato sauce and parmesan cheese.*

Average energy value for 1 serving: 825 kcal. - 3440 kJ

## RICE A LA TURQUE

(for 4)

**Preparation:** 10 mins

**Cooking time:** 16 mins 22 mins

**Ingredients:** 2 measures or 300 g long grain rice, 50 ml olive oil, 1 chopped onion, 400 ml chicken stock, 150 ml tomato puree, saffron, salt, pepper.

*Rinse the rice under running water. Place the olive oil, chopped onion and rice in the bowl. Stir well. Add the chicken stock and a pinch of saffron. Season. Close the lid and switch on. The appliance will automatically switch over to keep warm after 16 mins 22 mins cooking. Carefully mix in the tomato puree before serving.*

Average energy value for 1 serving: 770 kcal. - 3205 kJ



## PORTUGUESE RICE

(for 4)

**Preparation:** 15 mins

**Cooking time:**  16 mins  22 mins

**Ingredients:** 2 measures or 300 g long grain rice, 50 ml olive oil, 1 chopped onion, 2 tomatoes, 2 red peppers, 400 ml chicken stock, salt, pepper.

*Rinse the rice under running water. Peel the tomatoes and remove the seeds. Cut the red peppers into small pieces. Place the olive oil, chopped onion and rice in the bowl. Stir well. Add the tomatoes and peppers. Season and add the chicken stock. Close the lid and switch on. The appliance will automatically switch over to keep warm after  16 mins  22 mins cooking. Serve with tomato sauce and parmesan cheese.*

Average energy value for 1 serving: 750 kcal. - 3120 kJ



## SAFFRON RICE WITH SEA FOOD

(for 4)

**Preparation:** 10 mins

**Cooking time:**  16 mins  22 mins

**Ingredients:** 2 measures or 300 g long grain rice, 50 ml olive oil, 1 chopped onion, 400 ml fish concentrate, 200 g frozen sea food, saffron, salt, pepper.

*Rinse the rice under running water. Place the olive oil, chopped onion and rice in the bowl. Stir well. Include the frozen sea food. Add the fish concentrate and a pinch of saffron. Season. Close the lid and switch on. The appliance will automatically switch over to keep warm after  16 mins  22 mins cooking.*

Average energy value for 1 serving: 735 kcal. - 3050 kJ

## SOFT BOILED EGG

**Cooking time:** 8 mins

**Ingredients:** 5 eggs, 1 spoonful water.

*Place the water and steam bowl in the bowl and put the eggs on the bowl. Close the lid. Switch on. The appliance will automatically switch over to keep warm after 8 minutes cooking. Take the eggs out off the bowl and remove the shells under the tap. Serve au gratin with tomato or mornay sauce.*

## HARD BOILED EGG

**Cooking time:** 12 mins

**Ingredients:** 5 eggs, 2.5 spoonfuls water.

*Place the water and steam bowl in the bowl and put the eggs on the bowl. Close the lid. Switch on. The appliance will automatically switch over to keep warm after 12 minutes cooking.*

## PARISIAN POTATOES

(for 4)

**Preparation:** 5 mins**Cooking time:** 15 mins**Ingredients:** 300 g frozen potato cubes, 5 spoonfuls oil, 20 g butter, salt.



*Place the oil and the butter in the bowl. Add the potatoes. Season with salt. Close the lid and switch on. The appliance will automatically switch over to keep warm after 15 minutes cooking.*

Average energy value for 1 serving: 250 kcal. - 1050 kJ

## POLENT

(for 4)

**Preparation:** 10 mins**Cooking time:**  8 mins  12 mins**Ingredients:** 200 g corn flour, 850 ml water, 50 g butter, 50 g parmesan cheese, salt.



*Place the boiling water, salt and the butter in the bowl. Pour in the flour and mix well. Close the lid and switch on. The appliance will automatically switch over to keep warm after 8 minutes cooking. Open the lid after  8 mins  12 mins keeping warm and stir in the parmesan cheese. Pour into a dish for it to take shape. Unmould and serve. You can leave it to cool before cutting into pieces. Colour with butter in a frying pan or sprinkle with grated gruyère cheese au gratin.*

Average energy value for 1 serving: 315 kcal. - 1340 kJ

## ROMAN GNOCCHI

(for 4)

**Preparation:** 10 mins**Cooking time:**  12 mins  16 mins**Ingredients:** 750 ml beef stock, 150 g semolina, 100 g melted butter, salt, pepper, nutmeg.

*Place the stock, semolina, melted butter, salt, pepper and nutmeg in the bowl. Pour in the flour and mix well. Mix well. Close the lid and switch on. The appliance will automatically switch over to keep warm after  12 mins  16 mins cooking.*

*Serve with tomato sauce or au gratin.*

Average energy value for 1 serving: 410 kcal. - 1740 kJ



## MACARONI AND HAM PANCAKES

(for 4)

**Preparation:** 10 mins

**Cooking time:**  14 mins  17 mins

**Ingredients:** 200 g macaroni, 50 g butter, 1 slice ham, 20 g grated gruyère cheese, salt, 500 ml water.

*Cut the ham into small pieces. Place the butter, macaroni, ham, gruyère, water and salt in the bowl. Mix. Close the lid and switch on. The appliance will automatically switch over to keep warm after  14 mins  17 mins cooking. Turn the pancake onto a round plate before serving.*

Average energy value for 1 serving: 330 kcal. - 1400 kJ

## SPAGHETTI MILANESE

 (for 4)  (for 2)

**Preparation:** 15 mins

**Cooking time:** 10 mins

**Ingredients**  : 250 g spaghetti, 2 spoonfuls oil, salt, 50 g butter, 2 litres water.

**Ingredients**  : 150 g spaghetti, 2 spoonfuls oil, salt, 50 g butter, 1.5 litres water.

*Place the water, salt and oil in the bowl. Switch on and bring to the boil. Add the spaghetti, stir and allow to cook for 10 mins. Turn off. Drain off the water. Add the butter and serve with tomato sauce or parmesan cheese.*

*The "keep warm" fonction is not recommended with this recipe.*

Average energy value for 1 serving: 420 kcal. - 1750 kJ



## STEAMED FILLET OF TURBOT WITH FENNEL

(for 4)

**Preparation:** 5 mins

**Cooking time:**  15 mins  12 mins

**Ingredients:** 600 g turbot fillets, 100 ml water, fennel, salt.

*Place the water and steam bowl in the bowl. Place the fillets on the bowl and sprinkle with the fennel. Season with salt. Close the lid and switch on. The appliance will automatically switch over to keep warm after  15 mins  12 mins cooking.*

Average energy value for 1 serving: 105 kcal. - 450 kJ

## SCALLOPS EN PAPILOTTE

(for 4)

**Preparation:** 10 mins**Cooking time:** 15 mins

**Ingredients** 🍳 : 12 scallops, 2 shallots, 50 g butter, salt, pepper, 4 squares of tinfoil, 150 ml water.

**Ingredients** 🍳 : 6 scallops, 1 shallots, 25 g butter, salt, pepper, 2 squares of tinfoil, 100 ml water.

*Wash the scallops. Chop the shallots. Place 3 scallops on each square of tinfoil with a pinch of chopped shallots and a knob of butter. Season. Close the papillotes.*

*Place the water and steam bowl in the bowl. Place the papillotes in the steam bowl. Close the lid and switch on. The appliance will automatically switch over to keep warm after 15 minutes cooking. Serve in the tinfoil.*

Average energy value for 1 serving: 190 kcal. - 800 kJ

## TROUT FILLET EN PAPILOTTE

(for 4)

**Preparation:** 20 mins**Cooking time:** 15 mins

**Ingredients** 🍳 : 4 fillets of sea trout (approx. 120 g each), 50 g carrots, 50 g celery, 2 shallots, 50 g butter, salt, pepper, 4 squares of tinfoil, 150 ml water.

**Ingredients** 🍳 : 2 fillets of sea trout (approx. 120 g each), 25 g carrots, 25 g celery, 1 shallots, 25 g butter, salt, pepper, 2 squares of tinfoil, 100 ml water.

*Thinly chop the carrot and the celery. Chop the shallot. Place 1 trout fillet on each square of tinfoil with the carrot and celery and a pinch of chopped shallots and a knob of butter. Season. Close the papillotes.*

*Place the water and steam bowl in the bowl. Place the papillotes in the steam bowl. Close the lid and switch on. The appliance will automatically switch over to keep warm after 15 minutes cooking. Serve in the tinfoil.*

Average energy value for 1 serving: 190 kcal. - 800 kJ

## STEAMED ARTICHOKEs

🍳 (for 4) 🍳 (for 2)

**Preparation:** 5 mins**Cooking time:** 45 mins

**Ingredients** 🍳 : 4 small artichokes, 500 ml water.

**Ingredients** 🍳 : 2 small artichokes, 400 ml water.

*Trim the artichokes and wash well. Put the water and steam bowl in the bowl. Place the artichokes in the steam bowl. Close the lid and switch on. The appliance will automatically switch over to keep warm after 45 minutes cooking.*

Average energy value for 1 serving: 70 kcal. - 305 kJ

## STEAMED ASPARAGUS



 (for 4)  (for 2)

**Preparation:** 15 mins

**Cooking time:**  20 mins  25 mins

**Ingredients**  : 1 kg asparagus, 250 ml water.

**Ingredients**  : 750 g asparagus, 200 ml water.

*Peel the asparagus and wash well. Put the water and steam bowl in the bowl. Place the asparagus in the steam bowl. Close the lid and switch on. The appliance will automatically switch over to keep warm after  20 mins  25 mins cooking.*

Average energy value for 1 serving:  75 kcal. - 315 kJ  110 kcal. - 470 kJ

## STEAMED CHICORY

 (for 4)  (for 2)

**Preparation:** 5 mins

**Cooking time:** 45 mins

**Ingredients**  : 500 g chicory, 500 ml water, juice of 1/2 lemon.

**Ingredients**  : 400 g chicory, 300 ml water, juice of 1/2 lemon.

*Put the water and steam bowl in the bowl. Place the chicory in the steam bowl. Sprinkle with lemon juice and salt. Close the lid and switch on. The appliance will automatically switch over to keep warm after 45 minutes cooking.*

Average energy value for 1 serving:  20 kcal. - 90 kJ  30 kcal. - 140 kJ

## STEAMED SPINACH



 (for 4)  (for 2)

**Preparation:** 10 mins

**Cooking time:**  18 mins  15 mins

**Ingredients**  : 500 g spinach, 2 tablespoons water.

**Ingredients**  : 400 g spinach, 2 tablespoons water.

*Remove the stalks and wash the spinach well. Put the water and steam bowl in the bowl. Place the spinach in the steam bowl. Close the lid and switch on. The appliance will automatically switch over to keep warm after  18 mins  15 mins cooking.*

Average energy value for 1 serving:  30 kcal. - 125 kJ  25 kcal. - 100 kJ

## STEAMED POTATOES



 (for 4)  (for 2)

**Preparation:** 10 mins

**Cooking time:**  25 mins  20 mins

**Ingredients**  : 600 g potatoes, 250 ml water, salt.

**Ingredients**  : 400 g potatoes, 200 ml water, salt.

*Put the water and steam bowl in the bowl. Place the potatoes in the steam bowl. Add salt. Close the lid and switch on. The appliance will automatically switch over to keep warm after  25 mins  20 mins cooking.*

Average energy value for 1 serving:  135 kcal. - 560 kJ  560 kcal. - 780 kJ

## LEMON CREAM

(for 4)

**Preparation:** 20 mins**Cooking time:** 25 mins

**Ingredients:** 6 eggs, 250 g sugar, juice of 2 lemons, peel of 1 lemon, 250 ml water, 250 ml water for cooking.

*Heat the water sugar and lemon peel. Pour over the beaten eggs. Mix well and sieve. Pour the cream into 4 dishes. Cover with paper film. Place the 250 ml water in the bowl with the steam bowl. Place the dishes in the steam bowl. Close the lid and switch on. The appliance will automatically switch over to keep warm after 25 minutes cooking. Chill before serving.*

Average energy value for 1 serving: 400 kcal. - 1660 kJ

## CARAMEL CREAM

(for 4)

**Preparation:** 15 mins**Cooking time:** 25 mins

**Ingredients:** 500 ml milk, 3 eggs, 200 g sugar, vanilla, 250 ml water.

*Burn 100 g sugar with 2 tablespoons of water and pour into a pyrex mould (Ø 15 cm).*

*Beat the eggs with the sugar, milk and vanilla. Pour into the mould. Cover with paper film and place a plate over the mould. Place the water in the bowl with the steam bowl. Place the mould in the steam bowl. Close the lid and switch on. The appliance will automatically switch over to keep warm after 25 minutes cooking. Take out the mould and allow to cool. Unmould before serving.*

Average energy value for 1 serving: 350 kcal. - 1440 kJ

## VANILLA OATFLAKES

(for 4)

**Preparation:** 10 mins**Cooking time:** 16 mins

**Ingredients:** 250 ml milk, 80 g oat flakes, 50 g sugar, vanilla, 150 ml water.

*Mix the hot milk with the sugar and oat flakes. Leave for 5 minutes. Fill 4 buttered dishes. Cover with paper film. Place the water in the bowl with the steam bowl. Place the dishes in the steam bowl. Close the lid and switch on. The appliance will automatically switch over to keep warm after 16 minutes cooking. Unmould and serve. This recipe can be served with custard or liquid caramel.*

Average energy value for 1 serving: 160 kcal. - 650 kJ



## PEARS WITH CHOCOLATE SAUCE

(for 4)

**Preparation:** 10 mins

**Cooking time:**  20 mins  25 mins

**Ingredients:** 4 large ripe pears, 1 pinch of cinnamon, 200 ml water, 100 g cooking chocolate, 50 ml water, 50 ml cream.

*Peel the pears, but keep the stalk. Slowly melt the chocolate with the water and the cream. Mix. Keep warm. Place the water in the bowl with the steam bowl. Place the pears in the steam bowl and sprinkle with cinnamon. Close the lid and switch on. The appliance will automatically switch over to keep warm after  20 mins  25 mins cooking. Serve the pears coated with chocolate sauce.*

Average energy value for 1 serving: 220 kcal. - 920 kJ

## SCOTCH PUDDING

(for 4)

**Preparation:** 30 mins

**Cooking time:** 45 mins

**Ingredients:** 200 ml milk, 100 g bread, 150 g + 50 g sugar, 3 eggs, 100 g currants, 100 g ground almonds, 1 orange, 100 g butter, 1 pinch cinnamon, 100 ml rum, 500 ml water.

*Soak the bread in the milk for 5 minutes and drain off. Beat the eggs with 150 g sugar and add the bread, the currants and the ground almonds, the peel and juice of 1 orange, the melted butter and the cinnamon. Mix well. Pour the preparation into a buttered mould and cover with paper film. Place the water in the bowl with the steam bowl. Place the mould in the steam bowl. Close the lid and switch on. The appliance will automatically switch over to keep warm after 45 minutes cooking. Cut the pudding into slices. Sprinkle with sugar and flambé with rum. Serve.*

Average energy value for 1 serving: 825 kcal. - 3425 kJ

S.A. SEB SELONGEY CEDEX • RC. DIJON B 302 412 226 • REF. 5061478

RÉALISATION :  ADHOCSTUDIO