

UK Installation instructions

FI Asennusohje

LV Instalācijas instrukcija

DE Montageanleitung

FR Notice de montage

NO Monteringsanvisning

CZ Montážní návod

HU Szerelési útmutató

PL Instrukcja montażu

DK Monteringsvejledning

IT Istruzioni di montaggio

SE Installationsanvisning

EE Paigaldusjuhend

LT Montavimo Instrukcijos

RU ИНСТРУКЦИЯ ПО МОНТАЖУ

TYPE : RAZE ARCHI LARGE

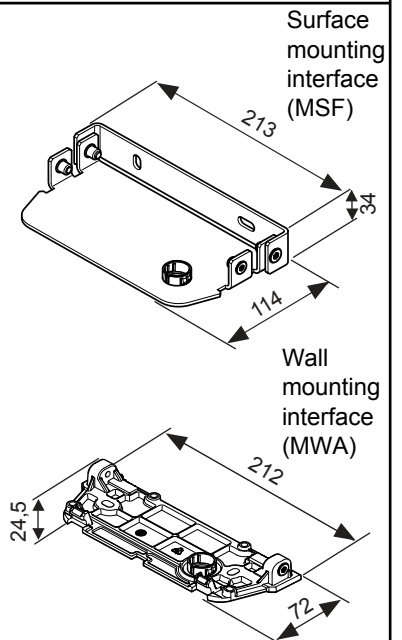
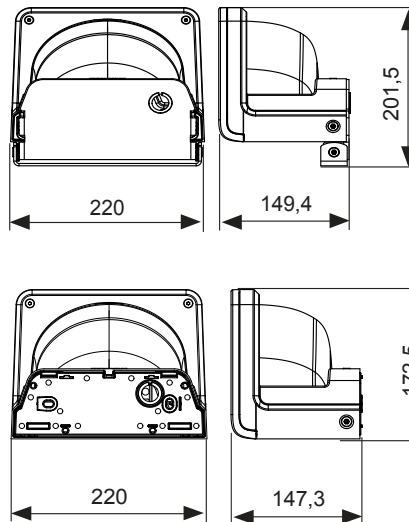
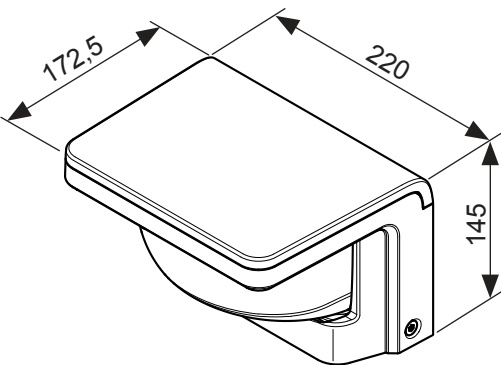

RAZE ARCHI LARGE	
	(kg)
Wall mounting (MWA)	2,8
Surface mounting (MSF)	2,85



CLASS II

IK10

IP66



T30 creux / Hollow



If the external flexible cable or cord of this luminaire is damaged, it shall be exclusively replaced by the manufacturer or his service agent or a similar qualified person in order to avoid any hazard.

1 WALL MOUNTING (MWA)

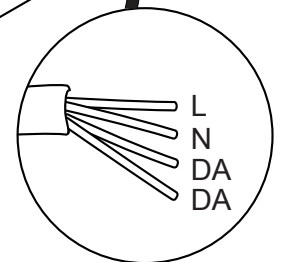
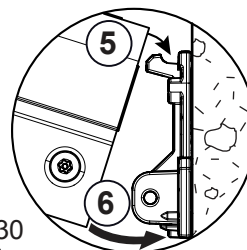
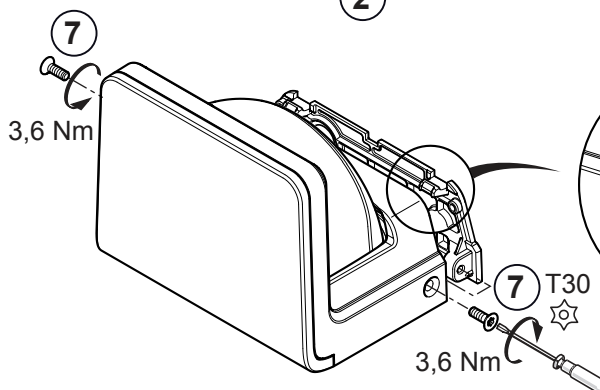
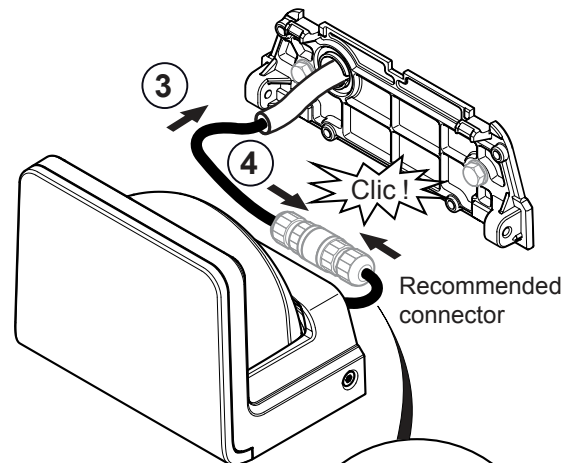
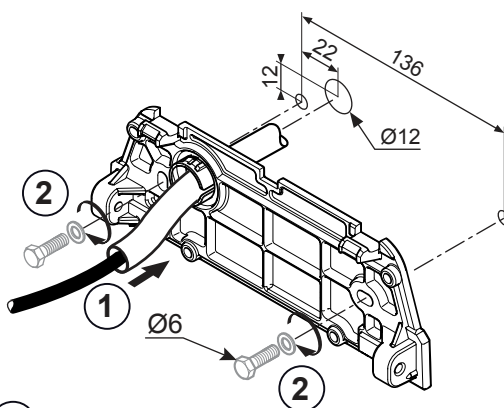
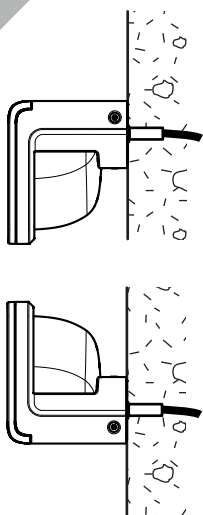

2

SURFACE MOUNTING (MSF)

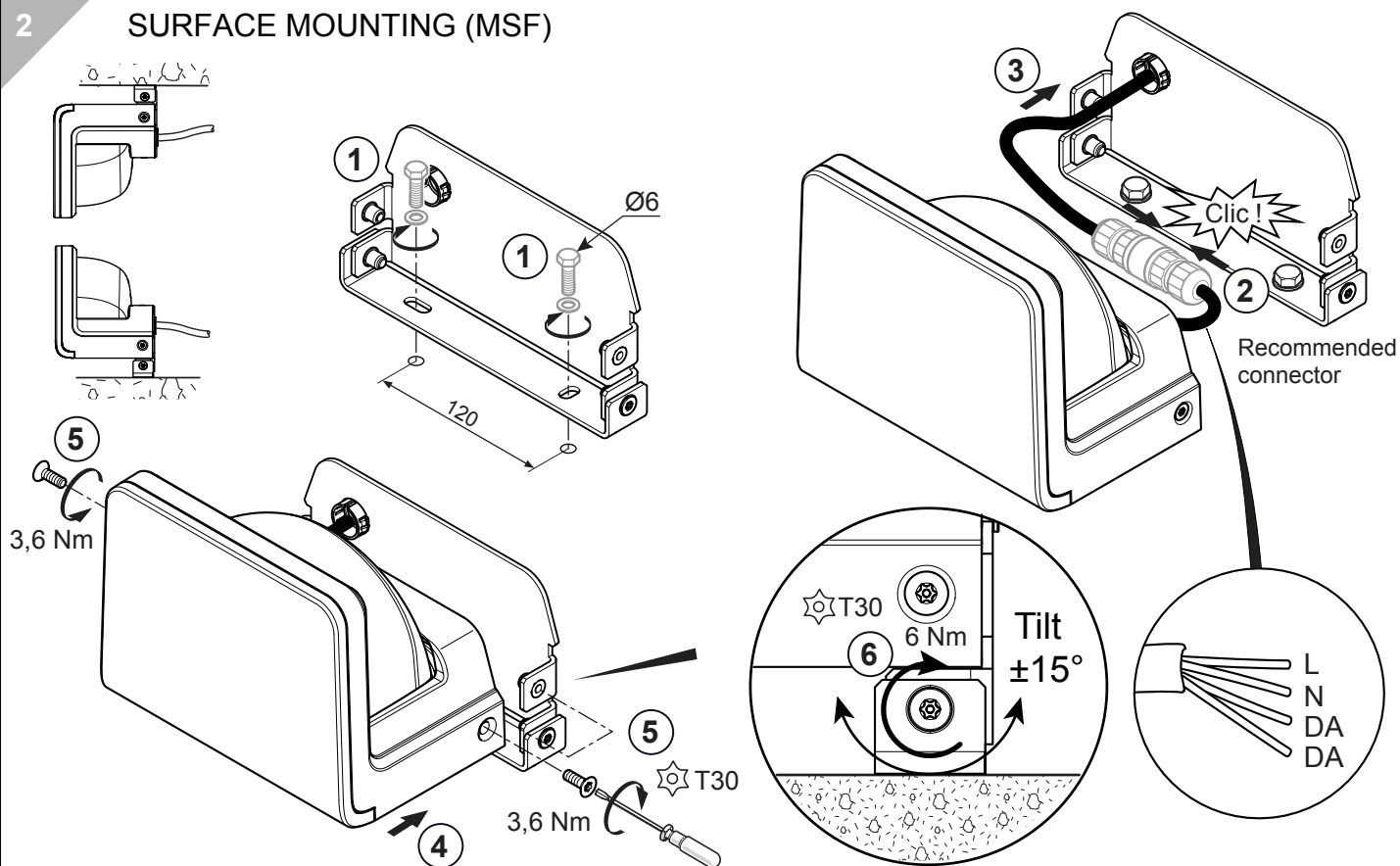

3

Recommended cable

H07RN-F

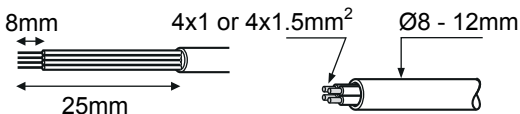

Recommended connector

H07RN-F	Male	TECHNO:THB.387.A4A
4x1mm ² or 4x1,5mm ²	Female	TECHNO:THB.387.B4A
	Kit	TECHNO:THB.387.A4A.R



EVERY 6 MONTHS

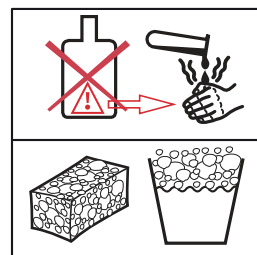

FRANCAIS

-Remplacer toute protection fissurée.
-Les luminaires classe II doivent être installés de façon à ce que la partie métallique ne soit pas en contact avec l'installation électrique connectée à la terre.

ATTENTION: Les luminaires classe I doivent être reliés à la terre.
-Ce luminaire fonctionne à une tension nominale qui doit être coupée avant toute intervention sur l'appareillage.
-Toute modification de cet appareil est interdite.
-Respecter la distance minimale par rapport aux objets éclairés définie par ce sigle.

SVERIGE

-Ersätta alla spräckta skyddsplåtar.
-Klass II armaturer måste installeras så att nakna metalldelar i armaturen inte är i kontakt med någon elektrisk installation, kopplad till en skyddledare.

WARNING: Klass I armaturer måste vara jordade.
-Denna armatur fungerar med högspänning som måste vara fränslagen före ingripande i driftdonen.
-Alla ändringar i denna armatur är förbjuden.

ITALIANO

-Sostituire sempre tutte le protezioni danneggiate.
-Gli apparecchi in classe II devono essere installati in modo che le parti metalliche non siano in contatto con apparati elettrici collegati a terra.
ATTENZIONE: Gli apparecchi in class I devono essere collegati a terra.
-Questo apparecchio funziona a tensione nominale, questa deve essere interrotta prima di ogni intervento sul gruppo di alimentazione.
-Ogni modifica dell' apparecchio è proibita.

ENGLISH

-Replace any cracked protective shield.
-Class II luminaires must be installed so that exposed metal work of the luminaire is not in contact with any part of the electrical installation connected to a protective conductor.
WARNING: Class I luminaires must be earthed.
-This luminaire operates at mains voltage which must be switched off before intervention in control gear.
-Any modification to this luminaire is forbidden.
-Lighted objects nearer than the minimal distance in the is forbidden.

DEUTSCH

-Ersetze jede gebrochene Schutzscheibe.
-Schutzklasse II Leuchten müssen so installiert werden, daß berührbare Metallteile nicht mit einem, an dem Schutzleiter angeschlossenen Teil der elektrischen Installation in Kontakt kommen können.
ACHTUNG: Schutzklasse I Leuchten müssen geerdet sein.
-Diese Leuchte wird mit Netzspannung betrieben. Bevor Eingriffe am Vorschaltgerät vorgenommen werden sowie vor Wartung und Installation, ist die Versorgungsspannung abzuschalten.
-Jede Änderung an dieser Leuchte ist verboten.

SUOMI

-Rikkoontunut suojalasi vaihdettava välittömästi uutsen vastaavaan.
-Asennettaessa suojausluokan II valaisinta on peruseristetyin johdon ja kosketeltavien metalliosien välinen kosketus tehokkaasti eristettävä.
VAROITUS: Suojausluokan I valaisin täytyy maadoittaa.
-Verkkojännite on kytkettävä pois ennen valaisimen huoltotoimenpiteitä.
-Valaisimen rakennetta ei saa muuttaa.