

TIMEGUARD®

2300W Dusk to Dawn Light Controller

Model: NSLDD1000 – White



Installation & Operating Instructions

1. General Information

These instructions should be read carefully and retained for further reference and maintenance.

2. Safety

- Before installation or maintenance, ensure the mains supply to the sensor is switched off and the circuit supply fuses are removed or the circuit breaker turned off.
- It is recommended that a qualified electrician is consulted or used for the installation of this sensor and install in accordance with the current IEE wiring and Building Regulations.
- Check that the total load on the circuit including when this sensor is fitted does not exceed the rating of the circuit cable, fuse or circuit breaker.

3. Technical Specifications

- 230V AC 50 Hz
- This PIR is of Class II Construction and must not be earthed
- Maximum Switching Load: 2300W Halogen Lighting
 500W Fluorescent Lighting
 80W LED Lighting
- Operation: Dusk – Dawn,
 Dusk to 2/4/8 hours OFF,
 (adjutable Dusk sensing)
- IP44 Rated suitable for restricted external applications
- CE Compliant
- EC Directives: Conforms to latest directives

4. Installation

- Ensure the mains supply is switched off and the circuit supply fuses are removed or the circuit breaker turned off.
- An isolating switch should be installed to enable the power to be switched ON & OFF for maintenance purposes.
- Open the unit by gently prying the "ears" on each side of the unit (See diagram "A"). This can be done without a tool, but if you prefer use a flat blade screwdriver, but be careful not to damage the clips. The front cover is hinged at the top and the front cover will swing open upwards.
- Mark the position of the fitting holes using the unit as a template. Drill out the mounting holes taking care to avoid any joists, electrical cables or water/gas pipes that may be hidden beneath the surface. Insert the rawl plugs into the holes.
- Pass the 230V 50Hz mains supply and load cables through the cable entry points on the unit, ensuring the grommet(s) is used to maintain the IP rating of the sensor.
- Fix the unit to the wall using the correct screws for the rawl plugs installed.
- Terminate the cables into the terminal block ensuring correct polarity is observed and that all bare conductors are sleeved (See section 5. Connection Diagram).
- Attach the supplied cable clamp ensuring not to overtighten.
- Close the front cover.

5. Connection Diagram

- Connect the cables to the terminal block as follows;

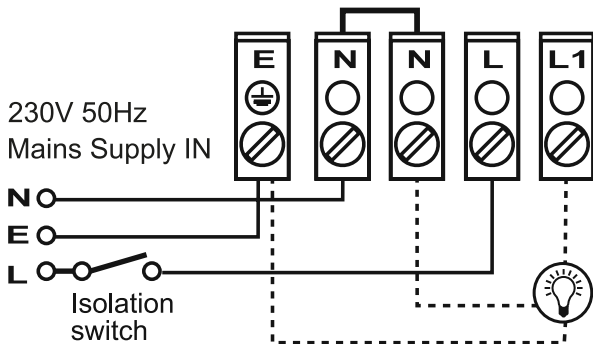

3

230V 50Hz Mains Supply IN

Live (Brown or Red) to L

Neutral (Blue or Black) to N

A 'Loop Terminal' is provided should a 3 core cable be used, which is marked .

Load

Switch Live (Brown or Red) to L1

Neutral (Blue or Black) to N

A 'Loop Terminal' is provided should a 3 core cable be used, which is marked .

Note: The N terminals are common.

Diagram A

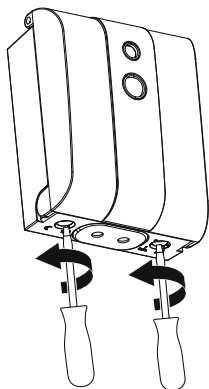

Front
cover
hinges
upwards

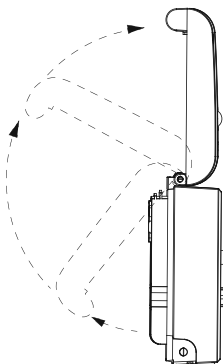

Diagram B

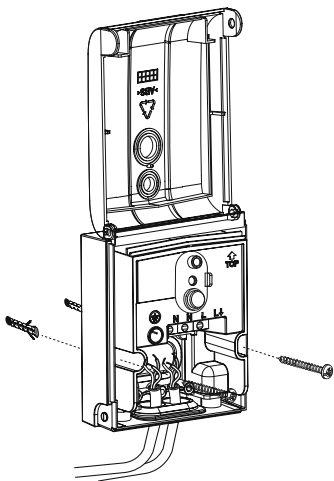
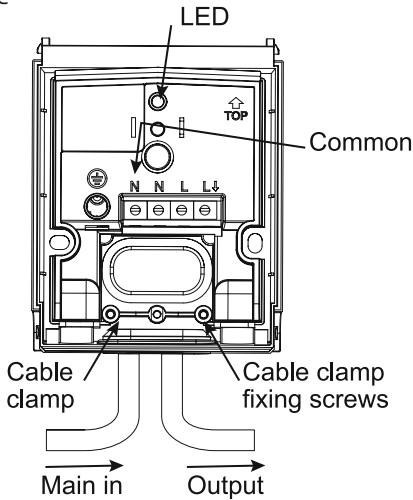

Diagram C



5

6. Testing

- The adjustment knobs located on the side of the sensor head (see diagram "D") are factory set to "Daylight Mode" i.e. LUX set to the 'Sun' symbol.

Diagram D

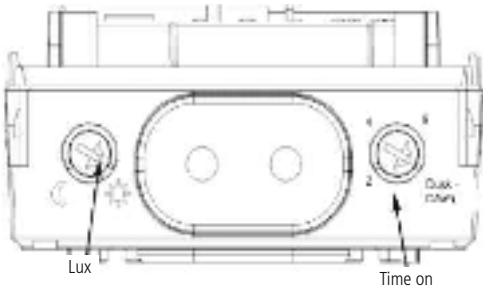

View on underside of unit shows adjustments

- The Dusk setting determines at which light level the NSLD1000 will turn its connected load "ON". Turning this setting fully clockwise allows you to test the circuit during daylight.
- Connect the unit to the mains and switch power ON.
- After a short delay, the unit will switch ON. This is indicated by the red LED (See diagram "C"). Any attached lights will also illuminate.

7. Setting up for Automatic Operation

- The TIME control determines how long the lamp remains illuminated after activation. There are 4 designated "time on" settings 2, 4, 8 hours and dusk until dawn.
 - The DUSK (LUX) control determines the level of darkness required for the unit to start operating. The setting is best achieved by the procedure below;
1. Set the Dusk control knob fully clockwise and the Time control to the required number of hours or dusk/dawn.
 2. When the ambient light level reaches the level of darkness at which you wish the lamp to become operative (i.e. at dusk) SLOWLY rotate the control in an anti-clockwise direction until a point is reached where the lamp illuminates.
 3. Leave the control set at this point.
- At this position the unit should become operative at approximately the same level of darkness each evening.
 - Observe the operation of the unit. If the unit is starting to operate too early (i.e. when it is quite light) adjust the control slightly anti-clockwise. If the unit starts to operate too late (i.e. when it is very dark). Adjust the control slightly clockwise.
 - Continue to adjust until the unit operates as desired.

8. Troubleshooting

Problem

Solution

- Light sensor will not operate at night. The level of ambient light in the area may be too bright to allow operation at the current DUSK setting. During the hours of darkness first turn the Time Delay knob to minimum then adjust the DUSK control slowly anti-clockwise until the lamp illuminates. Refer to previous section for more details.
- Light Controller activates during the daytime. Adjust the setting anti-clockwise to lower the level of ambient light required for activation.

3 Year Guarantee

In the unlikely event of this product becoming faulty due to defective material or manufacture within 3 years of the date of purchase, please return it to your supplier in the first year with proof of purchase and it will be replaced free of charge. For years 2 and 3 or any difficulty in the first year, telephone the helpline on 020 8450 0515.

Note: A proof of purchase is required in all cases. For all eligible replacements (where agreed by Timeguard) the customer is responsible for all shipping/postage charges outside of the UK. All shipping costs are to be paid in advance before a replacement is sent.



If you experience problems, do not immediately
return the unit to the store.

Telephone the Timeguard Customer Helpline:

HELPLINE

020 8450 0515

or email helpline@timeguard.com

Qualified Customer Support Coordinators will be online
to assist in resolving your query.



Deta Electrical Co Ltd

Panattoni Park, Luton Road,
Chalton, Bedfordshire, LU4 9TT

Sales Office: 020 8452 1112

or email csc@timeguard.com

www.timeguard.com