

TIMEGUARD®

Weathersafe Vision Single Gang 13A Outdoor RCD Fused Spur – Passive

Model: TGV105NP



Installation & Operating Instructions



1. General Information

These instructions should be read carefully and retained for further reference and maintenance.

Note: Timeguard reserve the right to alter these instructions at any time. Up to date instructions will always be available for download at www.timeguard.com

2. Safety

- Before installation or maintenance, ensure the mains supply to the switch, socket or spur is switched off and the circuit supply fuses are removed or the circuit breaker turned off.
- It is recommended that a qualified electrician is consulted or used for the installation of this IP66 rated switch, socket or spur and install in accordance with the current IEE wiring and Building Regulations.
- Check that the total load on the circuit including when this switch, socket or spur is fitted does not exceed the rating of the circuit cable, fuse or circuit breaker.
- Electricity can be dangerous; the use of an RCD should not be regarded as a substitute for basic electrical safety precautions.
- Always test the RCD before use. If the test procedure is not completed satisfactory or an appliance continues to trip the RCD seek professional advice and switch off the appliance.
- To clean use a clean dry cloth only. Do not use liquid cleaners.
- During use warming of the enclosure is normal.

Wiring tests – Important (TGV105NP)

- Remove this product from the circuit if carrying out tests (as described in the IEE Wiring Regulations) for earth loop impedance, prospective short circuit current and insulation resistance.
- Use the enclosed warning label to ensure this is carried out.

3. Technical Specifications

- Mains supply: 230V AC 50Hz
- Class protection: Class I
- IP Rating: IP66
- All products in the range comply with the low voltage directive 2014/35/EU and where relevant the EMC directive 2014/30/EU and ROHS directive 2011/65/EU & 2015/863.
- Operating temperature: -5° to 55°C
- Lockable cover facility
- Rated trip current: 30mA
- RCD Type: Double pole, suitable for 2 and 3 wire applications.
- Breaking capacity: 250A Earth leakage)
- Through fault withstand: 1500A
- Trip speed: Less than 40msec at 150mA
- Classification: Latching (Passive)
- Complies with: BS7288 & BS1363

4. Installation

- **IMPORTANT** Switch off the electricity at the fuse box by removing the relevant fuse or switching off the circuit breaker before proceeding with the installation.
- Using a Philips screwdriver, separate the faceplate from the back box by removing the four screws located in each corner.

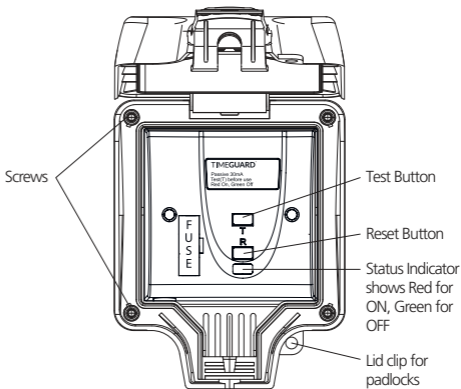

- Using the back plate as a template mark the position for the holes. Note the back plate must be mounted in the correct orientation, following the 'TOP' marking inside the back plate. If the mounting position desired is uneven use a sheet of marine ply as a base plate and fit the back box.

- Drill the wall using a 4mm Ø drill bit making sure not to infringe or compromise any gas, water pipes or cables. Insert the rawl plugs into the holes.
- The drain feature must be drilled out using a 5mm drill if the top or side entry conduit is used. Opening this drain hole will reduce the IP rating of the product. Remember to open out the lower drain feature only.
- Select the required cable entry point by knocking out the appropriate hole located on all four sides of the back box. If conduit is not going to be used, a waterproof cable with suitable IP rated 20mm cable glands will be required to maintain the overall IP rating. If the bottom entry conduit is used, there must be adequate drainage from the lowest point of the conduit. The same method should be used to create an exit point for the output supply cable to follow through on.
- Secure the back box to the wall using suitable screws for the rawl plugs installed. Ensure that the back box is correctly orientated following the 'TOP' marking which is labelled inside.
- Pass through the 230V AC 50Hz mains supply cable and secure the cables tightly to their respective terminals ensuring that all bare conductors are sleeved and that correct polarity is observed, see section 5. Note that if metal conduit is being used the earth continuity between the conduits must be maintained.
- Once the mains supply is connected to the correct terminals, mount the face plate over the back box aligning the four screws from the face plate to the four mounting holes on the back box. Tighten until secured.

5. Connection Diagram

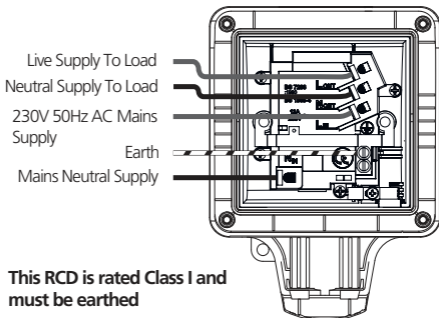

This RCD is rated Class I and must be earthed

5

230V AC 50Hz AC Mains Supply

Live (Brown or Red) to **L IN**

Neutral (Blue or Black) to **N IN**

Load

Live (Brown or Red) to **L OUT**

Neutral (Blue or Black) to **N OUT**

6. Testing & Usage

To test: Ensure supply is connected

RESET – press the grey (blue for TGV205NP) button marked Reset (R), the status indicator should show red.

Test – Press the Red Test button marked (T), the status indicator should show Green. This indicates the RCD has been tripped and power has been disconnected.

RESET – press the grey (blue for TGV205NP) button marked reset (R) again; the status indicator should show red.

If all the above operations work satisfactory, the RCD is safe for use.

If this test procedure is not completed to a satisfactory standard, do not use the RCD and seek professional advice.

In applications such as hand driers it may not be practical to expect each user to test before use. In this case we suggest an appropriate person applies the test routine twice a day.

After satisfactory testing the RCD, any connected appliance may be switched on, and used in the confidence that the user is protected from electric shock by rapid disconnection of the supply.

6

3 Year Guarantee

In the unlikely event of this product becoming faulty due to defective material or manufacture, within 3 years of the date of purchase, please return it to your supplier with proof of purchase and it will be replaced free of charge. For years 2 to 3 or with any difficulty in the first year, telephone our helpline. Note: a proof of purchase is required in all cases. For all eligible replacements (where agreed by Timeguard), the customer is responsible for all shipping/postage charges outside of the UK. All shipping costs are to be paid in advance before a replacement is sent.



If you experience problems, do not immediately return the unit to the store.

Email the Timeguard Customer Helpline:

HELPLINE

helpline@timeguard.com

or call the helpdesk on 020 8450 0515

Qualified Customer Support Coordinators will be online to assist in resolving your query.



Deta Electrical Co Ltd

Panattoni Park, Luton Road,
Chalton, Bedfordshire, LU4 9TT

Sales Office: 020 8452 1112

or email csc@timeguard.com

www.timeguard.com