

# TOLSEN FORCE XPRESS

## 79610 VACUUM CLEANER

INSTRUCTION MANUAL 220-240V~50/60HZ, 3000W, 80L

CE

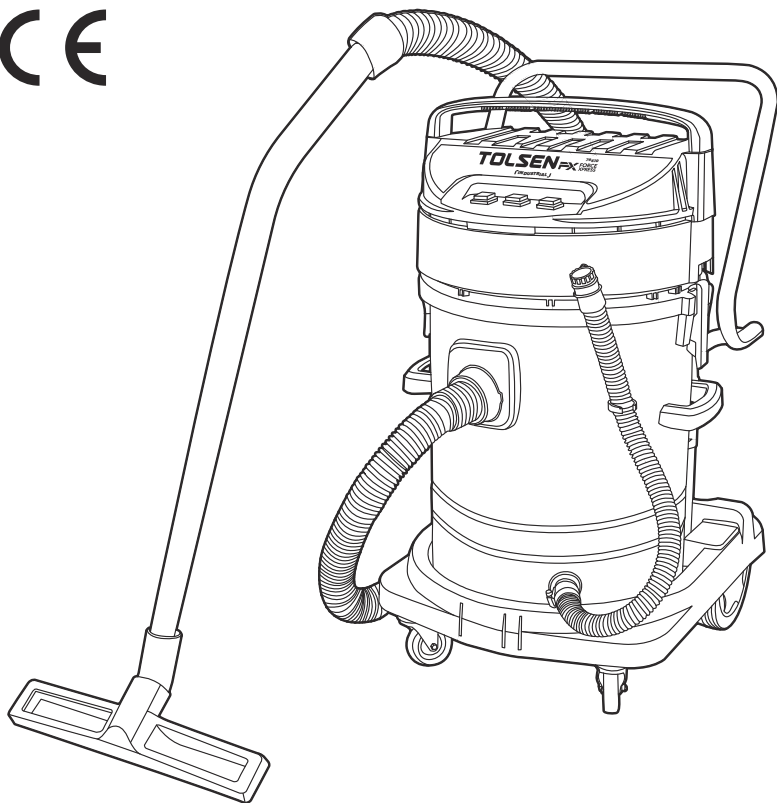

**SAVE THIS MANUAL !**

You will need this manual for safety instructions, operating procedures and warranty.  
Put it and the original sales receipt in a safe dry place for future reference.

## IMPORTANT SAFETY INSTRUCTIONS

When using an electrical appliance, basic precautions should always be followed, including the following:

### READ ALL INSTRUCTIONS BEFORE USING THIS APPLIANCE

#### **⚠WARNING**

To reduce the risk of fire, electric shock, or injury:

1. Do not leave appliance when plugged in. Unplug from outlet when not in use and before servicing.
2. Do not expose to rain. Store indoors.
3. Do not allow to be used as a toy. Close attention is necessary when used by or near children.
4. Use only as described in this manual. Use only manufacturer's recommended attachments.
5. Do not use with damaged cord or plug. If appliance is not working as it should, has been dropped, damaged, left outdoors, or dropped into water, return it to a service center.
6. Do not pull or carry by cord, use cord as a handle, close a door on cord, or pull cord around sharp edges or corners. Do not run appliance over cord. Keep cord away from heated surfaces.
7. Do not unplug by pulling on cord. To unplug, grasp the plug, not the cord.
8. Do not handle plug or appliance with wet hands.
9. Do not put any object into openings. Do not use with any opening blocked; keep free of dust, lint, hair, and anything that may reduce air flow.
10. Keep hair, loose clothing, fingers, and all parts of body away from openings and moving parts.
11. Turn off all controls before unplugging.
12. Use extra care when cleaning on stairs.
13. Do not use to pick up flammable or combustible liquids, such as gasoline, or use in areas where they may be present.
14. This appliance is provided with double insulation. Use only identical replacement parts. See instructions for Servicing of Double-Insulated Appliances.
15. Do not pick up anything that is burning or smoking, such as cigarettes, matches, or hot ashes.
16. Do not use without dust bag and/or filters in place.
17. FOR HOUSEHOLD USE ONLY.
18. Dry your hands and feet before touching plug or switch.
19. Do not continue to use the vacuum when the tank is full of liquid.
20. Do not use to pick up water from containers, i.e., sinks, tubs, barrels, etc.
21. Stay alert, watch what you are doing and use common sense when operating an appliance. Do not use an appliance while you are tired or under the influence of drugs, alcohol or medication. A moment of inattention while operating appliances may result in serious personal injury.
22. Maintain labels and nameplates on the appliance. These carry important safety information. If unreadable or missing, contact TOLSEN Tools for a replacement.
23. People with pacemakers should consult their physician(s) before use. Electromagnetic fields in close proximity to heart pacemaker could cause pacemaker interference or pacemaker failure.
24. The warnings, precautions, and instructions discussed in this instruction manual cannot cover all possible conditions and situations that may occur. It must be understood by the operator that common sense and caution are factors which cannot be built into this product, but must be supplied by the operator.

## **Servicing of Double-insulated appliances**

---

A double-insulated appliance is marked with one or more of the following: The words "DOUBLE INSULATION" or "DOUBLE INSULATED" or the double insulation symbol (square within a square):



In a double-insulated appliance, two systems of insulation are provided instead of grounding.

No grounding means is provided on a double-insulated appliance, nor should a means for grounding be added to the appliance. Servicing a double-insulated appliance requires extreme care and knowledge of the system, and should be done only by qualified service personnel. Replacement parts for a double-insulated appliance must be identical to the parts they replace

**SPECIFICATIONS**

Electrical Rating	220-240V~50/60Hz
Input power	3000W
Tank Capacity	80L

**SETUP - BEFORE USE:**

Read the **ENTIRE IMPORTANT SAFETY INFORMATION** section at the beginning of this manual including all text under subheadings therein before set up or use of this product.

**⚠WARNING**

**TO PREVENT SERIOUS INJURY FROM ACCIDENTAL OPERATION:** turn the power Switch of the appliance off and unplug the appliance from its electrical outlet before performing any procedure in this section.

**NOTE:** For additional information regarding the parts listed in the following pages, refer to the Assembly Diagram near the end of this manual.

## Components and controls

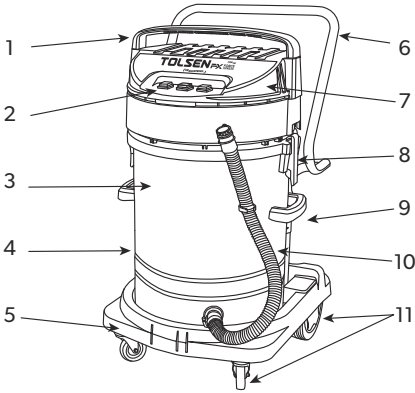

- 1. Engine cover handle
- 2. Start/Stop Switches
- 3. Entry suction tube
- 4. Bidone waste/liquid collection
- 5. Base
- 6. Wheel shift handle
- 7. Cover / Motor Body
- 8. Hook for closing between lid and bin
- 9. Handle
- 10. Emptying hose
- 11. Pivoting wheels and big wheels



HOSE



METAL TUBE



LONG-SQUARE  
BRUSH



ROUND  
BRUSH



BIG  
NOZZLE



SPONGE  
FILTER



COTTON  
BAG

## Assembly

1. Pull Clips outward, then remove Power Head by its Handle.

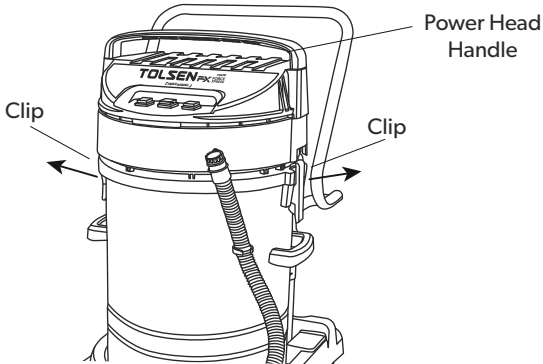

2. Remove contents from Tank, then turn Tank over and attach Swivel Casters with Screws.

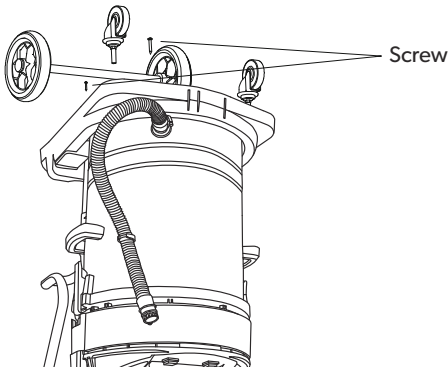

3. For dry vacuuming: Slide Filter over Filter Cage.

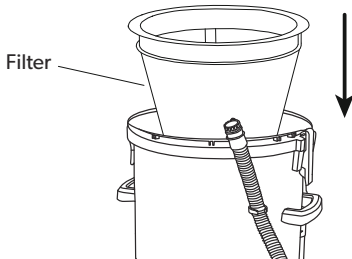

4. For wet vacuuming: Remove Filter.
5. Replace Power Head with Power Switch facing forward. Secure with Clips.
6. Push end of Hose into Vacuum Port until clip on Hose clicks into tab on Port.
7. Add Extension Wand(s) and Nozzles as needed.

## MAINTENANCE AND SERVICING



Procedures not specifically explained in this manual must be performed only by a qualified technician.

### **⚠WARNING**

**TO PREVENT SERIOUS INJURY FROM ACCIDENTAL OPERATION:** turn the power Switch of the appliance off and unplug the appliance from its electrical outlet before performing any procedure in this section.

**TO PREVENT SERIOUS INJURY FROM APPLIANCE FAILURE:** Do not use damaged equipment. if abnormal noise or vibration occurs, have the problem corrected before further use.

## Cleaning, maintenance, and lubrication

---

1. **BEFORE EACH USE**, inspect the general condition of the appliance. Check for:
  - loose hardware
  - misalignment or binding of moving parts
  - air leakage on the Tank or Power Head connection
  - cracked or broken parts
  - damaged electrical wiring
  - any other condition that may affect its safe operation.
2. **AFTER USE**, wipe external surfaces of the appliance with clean cloth. Store in an indoor dry area out of reach of children.
3. All parts are permanently lubricated. Do not use additional lubrication.
4. **WARNING!** If the supply cord of this appliance is damaged, it must be replaced only by a qualified service technician.

## Cleaning filter

---

To ensure proper operation, clean the Filter regularly. Torn Filter should be replaced:

1. Remove Filter.
2. Tap or shake Filter into a waste can.
3. If needed, flush with plain water from the inside. allow the Filter to dry for at least 24 hours before replacing.



**WARNING!** installing a wet Filter will increase the risk of electric shock and may damage the vacuum.

4. Replace Filter.

## PARTS LIST

NO.	Part name	Qty	NO.	Part name	Qty
1	Handbar screw 4x80	8	31	Cotton bag	1
2	Handbar	1	32	Clamps sets	2
3	Switch	3	33	Water out sets	1
4	Top cover screw 4x65	2	34	Screw 4x12	8
5	Top cover screw 4x25	5	35	Side hand bar	2
6	Top cover	1	36	Hose frame	2
7	Screw 4x18	2	37	M5x20	4
8	Cabel press board	1	38	Screw 4x20	7
9	Cabel	1	39	Tank 70l	1
10	Cabel protector	1	40	Air-inlet ring	1
11	Top cover screw 4x55	2	41	Air-inlet base	1
12	Line hole cover	1	42	Hose	1
13	Middle cover	1	43	Wheels	2
14	Resistence capacitor	2	44	Water outlet sets	1
15	Motor cooling seal	2	45	Metal tube sets	1
16	Top cover screw 4x45	3	46	Base	1
17	Motor cover	1	47	Static chain	1
18	Sealing ring of motor	2	48	Big wheels sets	2
19	Motor noise reduction sponge	2	49	Rear wheel clamps set	1
20	Motor	2	50	Rear wheel alex	1
21	Sealing ring of motor	2	51	Screw 4x16	11
22	Angel frame 19+20	3	52	Big nozzle	1
23	Botton cover	1	53	Floor brush for dry	1
24	Seal for botton cover	1	54	Floor brush for wet	1
25	Seal cover for botton	1	55	Round brush	1
26	Safety valve	1	56	Screw5x20	7
27	Botton cover bascket	1	57	Screw5x40	2
28	Push rod	1	58	Foam filter for wet	1
29	Iron alex	1	59	Wind cover	1
30	Cotton bag frame	1			

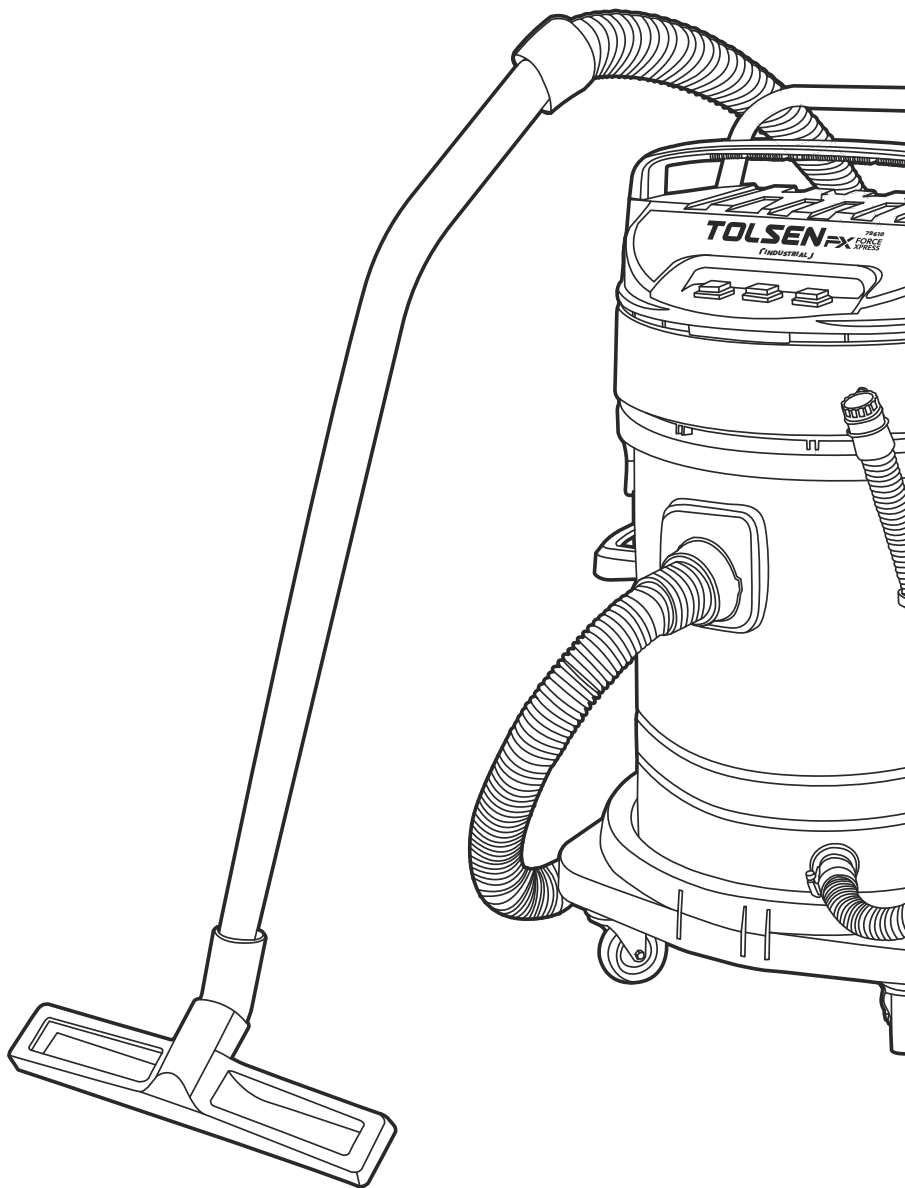

SUZHOU TOLSEN  
TOOLS CO.,LTD.

[www.tolseentools.com](http://www.tolseentools.com)

TOLSEN is a trademark or  
registered trademark of TOLSEN  
TOOLS. All rights reserved.  
MADE IN CHINA

