



**Count on it.**

**Parts Catalog**

**22in Recycler® Lawn Mower**

Model No. 20334—Serial No. 312000001 and Up



# Ordering Replacement Parts

To order replacement parts, please supply the part number, the quantity, and the description of each part desired.

## Understanding Reference Numbers

Each identified part in an illustration has a reference number. The reference number for a part also appears in the parts list, along with other information about the part.

This catalog uses two special reference number formats, one to indicate parts in a service assembly and another to indicate the quantity of a given part in an illustration.

## Service Assembly Reference Numbers

Parts in service assemblies have reference numbers in the form a:b. The a represents the reference number of the entire service assembly and the b represents a sequential number unique to each part within the service assembly.

For example, a wheel assembly might be identified by reference number 6, the tire by 6:1, the valve by 6:2, and the wheel by 6:3. When you order the assembly identified by reference number 6, you receive all parts identified by reference numbers 6:1, 6:2, and 6:3. However, you may also order any part individually. Reference numbers of this type appear in illustration and in parts lists.

## Reference Numbers Indicating Quantity

In an illustration, if a reference number indicates more than one part, the reference number has the form nX y. The n represents the quantity of the part, the X is the multiplication symbol, and the y represents the reference number.

For example, in an illustration, the reference number 2X 37 means that two of the parts identified by reference number 37 are indicated.

# List of Abbreviations

**AR:** as required

**ASM:** assembly

**BBC:** blade brake control

**BHTF:** button head thread forming

**CARR:** carriage

**CCW:** counter clockwise

**CW:** clockwise

**DEG:** degrees

**DPA:** Dual Point Adjustment

**ECM:** electronic control module

**EXT:** external

**FH:** flat head

**GA:** gauge

**HD:** heavy-duty

**HF:** hex flange

**HH:** hex head

**HHF:** hex head flange

**HHFTF:** hex head flange thread forming

**HJ:** hex jam

**HLH:** hex lag head

**HOC:** height-of-cut

**HSBH:** hex socket button head

**HSFH:** hex socket flat head

**HSH:** hex socket head

**HWH:** hex washer head

**HWHTF:** hex washer head thread forming

**HYD:** hydraulic

**LH:** left hand

**LPG:** Liquid Propane Gas

**NI:** nylon insert

**NPTF:** national pipe thread fine

**PFH:** phillips flat head

**PPH:** phillips pan head

**PPHTF:** phillips pan head thread forming

**PRH:** phillips round head

**PTH:** phillips truss head

**PTO:** power-take-off

**RH:** right hand

**ROPS:** roll-over protection system

**RRB:** rear roller brush

**SFH:** slotted fillister head

**SHH:** slotted hex head

**SHWH:** slotted hex washer head

**SPH:** slotted pan head

**SQH:** square head

**SRH:** slotted round head

**STD:** standard

**TAP:** self tapping

**TTH:** torx truss head

# Contents

Deck, Side Chute and Rear Door Assembly .....	4
Rear Bag Assembly .....	5
Engine and Blade Assembly .....	6
Front Wheel and Height-of-Cut Assembly .....	7
Transmission and Rear Wheel Drive Assembly .....	8
Handle Assembly .....	9
Electrical Assembly .....	10
Attachments and Accessories .....	11

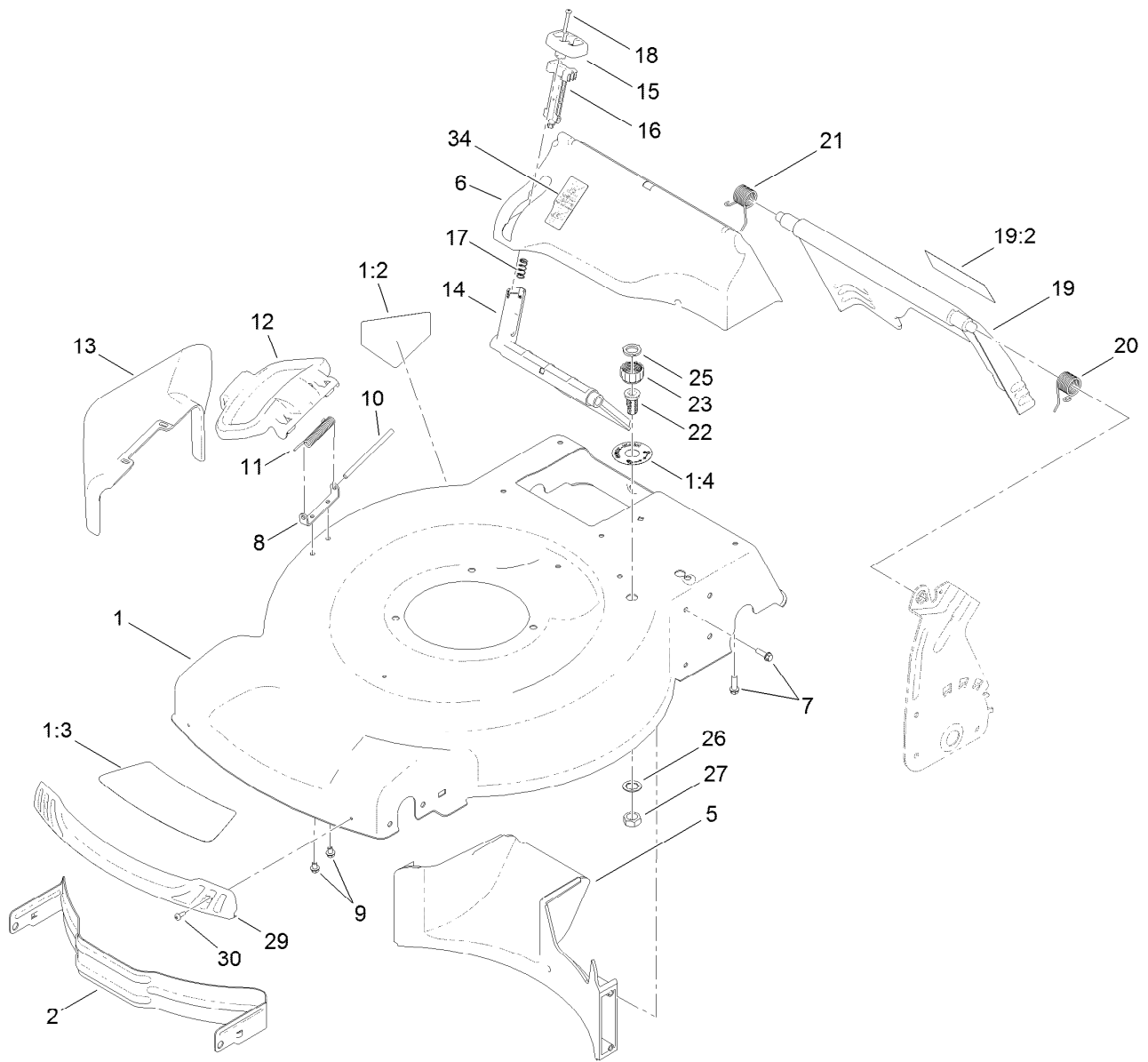

## Deck, Side Chute and Rear Door Assembly

<i>Ref.</i>	<i>Part Number</i>	<i>Qty.</i>	<i>Description</i>	<i>Ref.</i>	<i>Part Number</i>	<i>Qty.</i>	<i>Description</i>
1	117-1084	1	Housing ASM	16	114-7959	1	Latch-Recycle
1:2	94-8072	1	Decal-Danger	17	117-1031	1	Spring-Compression
1:3	115-4676	1	Decal-Recycler	18	32104-120	2	Screw-PPH
1:4	112-8867	1	Decal-Port, Washout	19	121-5776	1	Rear Door ASM
2	114-7963-01	1	Baffle-Front	19:2	114-7982	1	Decal-Warning
5	114-7961	1	Baffle-Rear	20	115-2859	1	Spring-Torsion
6	114-7957	1	Chute-Recycle	21	114-7924	1	Spring-Torsion
7	46-8091	9	Screw-HWH	22	112-6400	1	Port-Washout
8	112-6416	1	Bracket-Cover	23	112-6401	1	Coupling-Hose, Washout Port
9	99-8445	2	Screw-HWH, Taptite	25	112-6438	1	Washer-Seal, Washout Port
10	99-5291	1	Rod-Cover	26	3254-5	1	Washer-Tooth, Internal
11	99-5293	1	Spring-Torsion	27	3218-6	1	Nut-Jam
12	115-8449	1	Deflector-Side	29	114-7987	1	Bumper
13	115-8447	1	Chute-Discharge, Side	30	105-6849	2	Screw-Thread Forming
14	114-7960	1	Deflector-Recycle	34	117-5928	1	Decal-Bag On Demand
15	114-7958	1	Knob-Recycle				

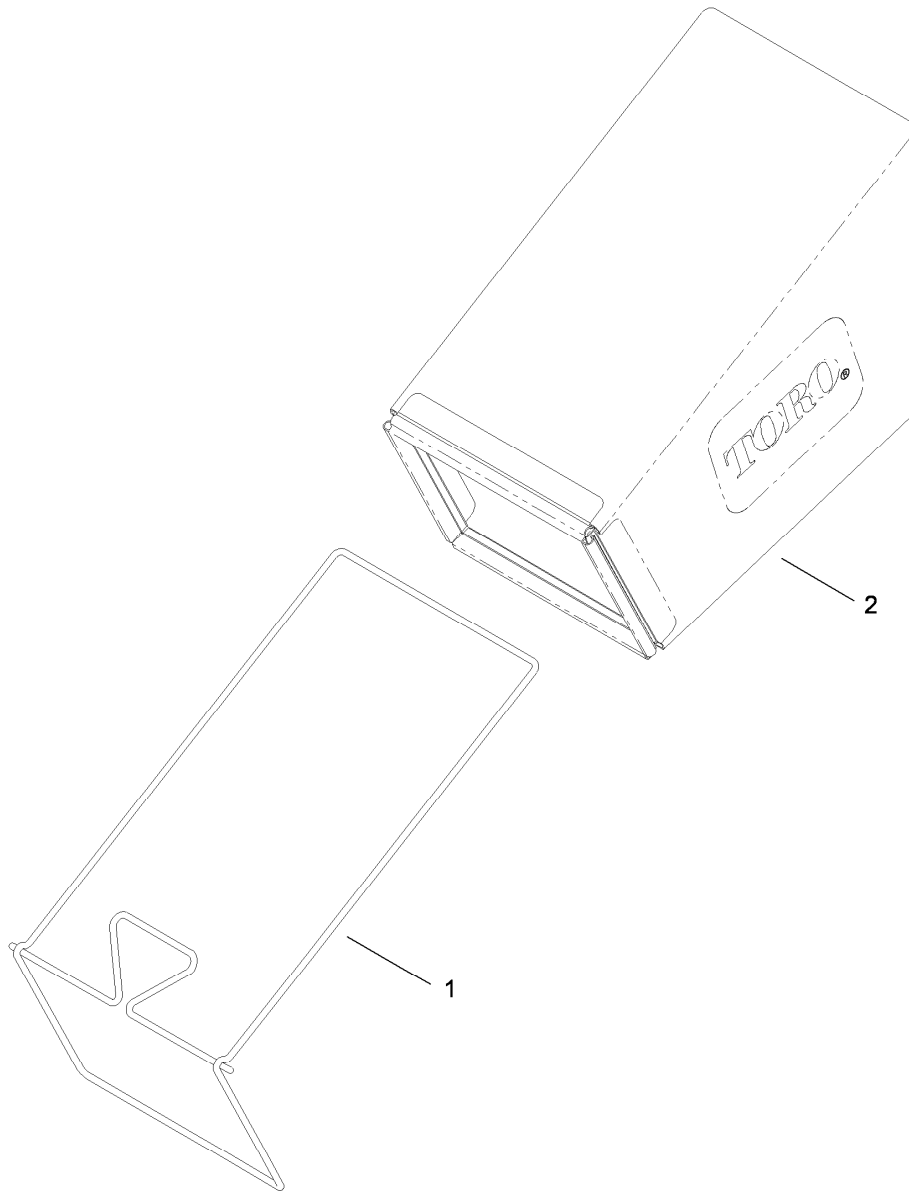

## Rear Bag Assembly

<i>Ref.</i>	<i>Part Number</i>	<i>Qty.</i>	<i>Description</i>
1	114-2679-03	1	Frame-Bag
2	115-4673	1	Grass Bag ASM

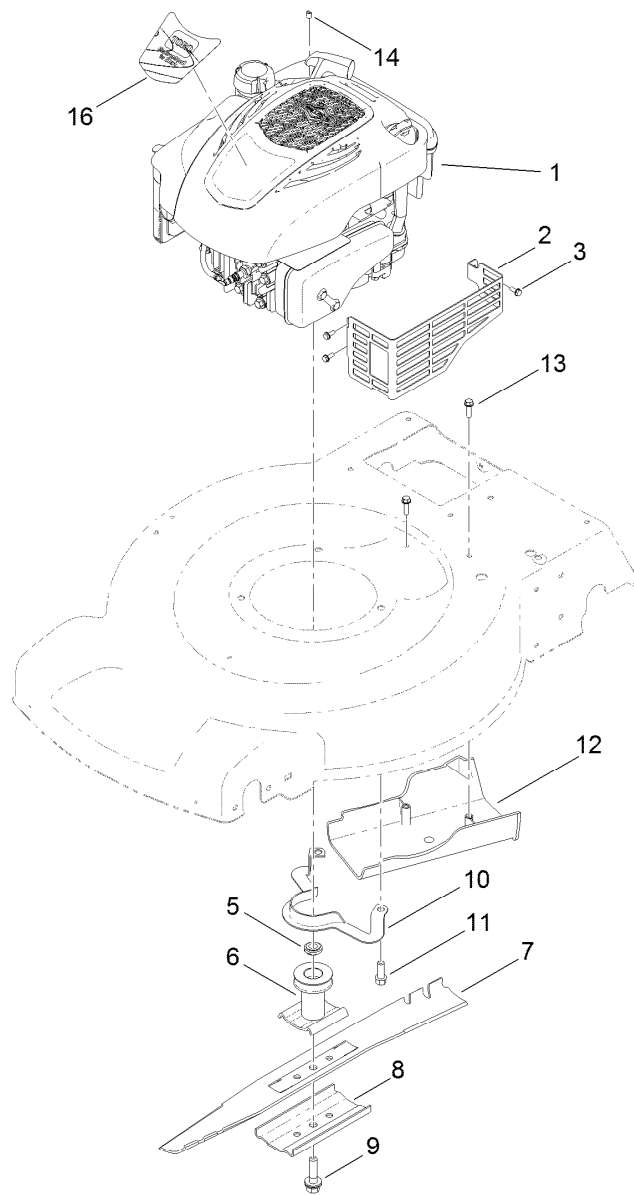

## Engine and Blade Assembly

Ref.	Part Number	Qty.	Description
1		1	Engine-Briggs, 128M05-3423-B1 ●■
2	104-7577-03	1	Shield-Muffler
3	32144-1	3	Screw-Taptite
5	106-3999	1	Spacer-Driver
6	106-3987	1	Blade Driver ASM
7	108-9764-03	1	Blade-22 Inch
8	108-3766-03	1	Support-Blade
9	105-8579	1	Bolt-Blade
10	105-3030-03	1	Guide-Belt
11	95-1726	3	Screw-Taptite
12	114-7937	1	Cover-Belt
13	46-8091	2	Screw-HWH
14	2210-316	1	Stop-Rope
16	121-2371	1	Decal-Shroud

● Not serviced separately

■ Obtain parts from [www.briggsandstratton.com](http://www.briggsandstratton.com)

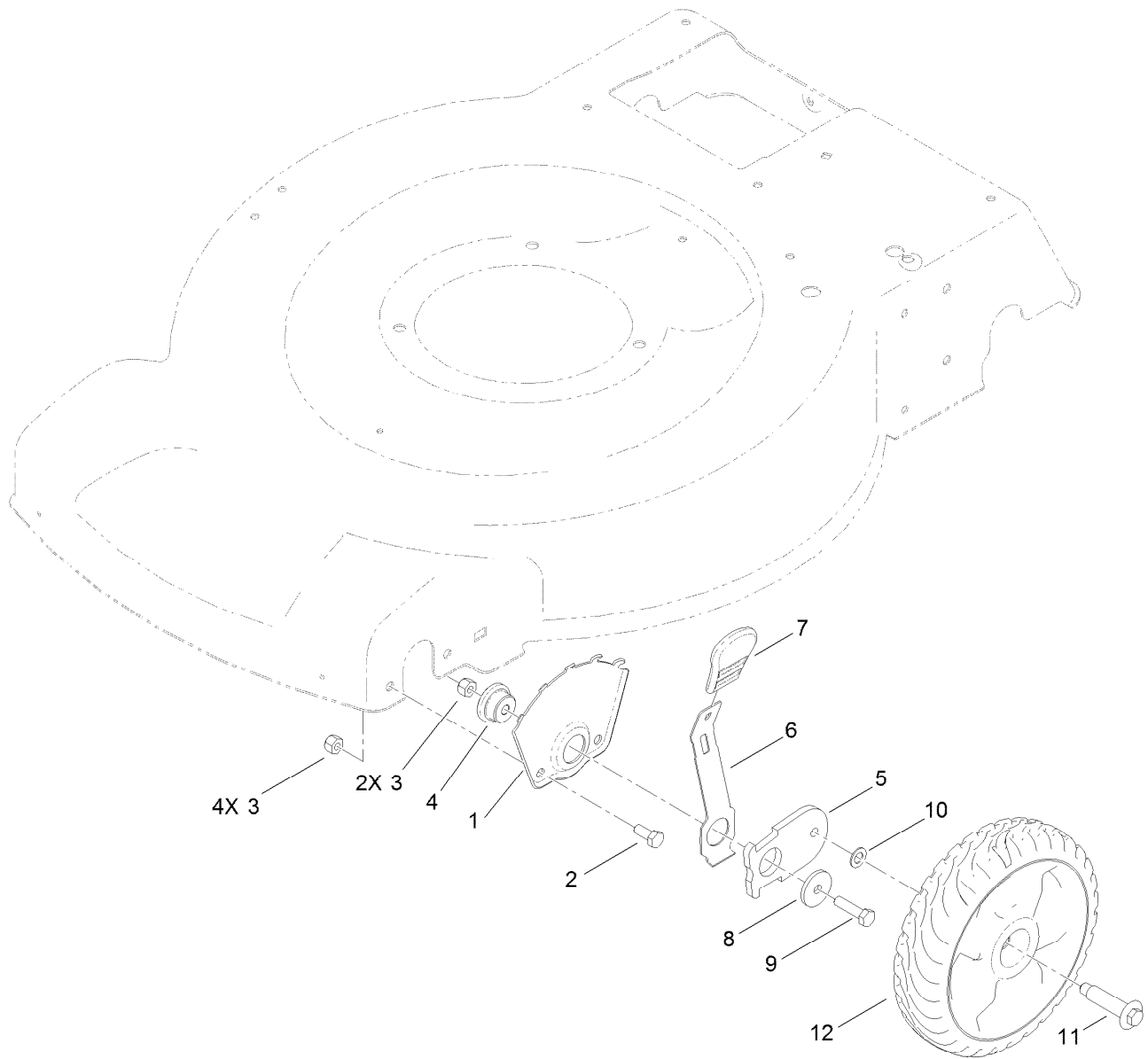

## Front Wheel and Height-of-Cut Assembly

Ref.	Part Number	Qty.	Description
1	115-1956-03	2	Plate-HOC, Front
2	322-3	4	Screw-HH
3	3296-29	6	Nut-Lock, NI
4	105-1818	2	Bushing-Mount, HOC
5	105-1807	2	Arm-Pivot, Front
6	105-1809	2	Arm-Spring
7	110-0549	2	Knob-HOC
8	105-3048	2	Washer-Flat
9	322-6	2	Screw-HH
10	40-1940	2	Washer
11	614650	2	Bolt-Shoulder
12	115-2894	2	8 Inch Wheel ASM

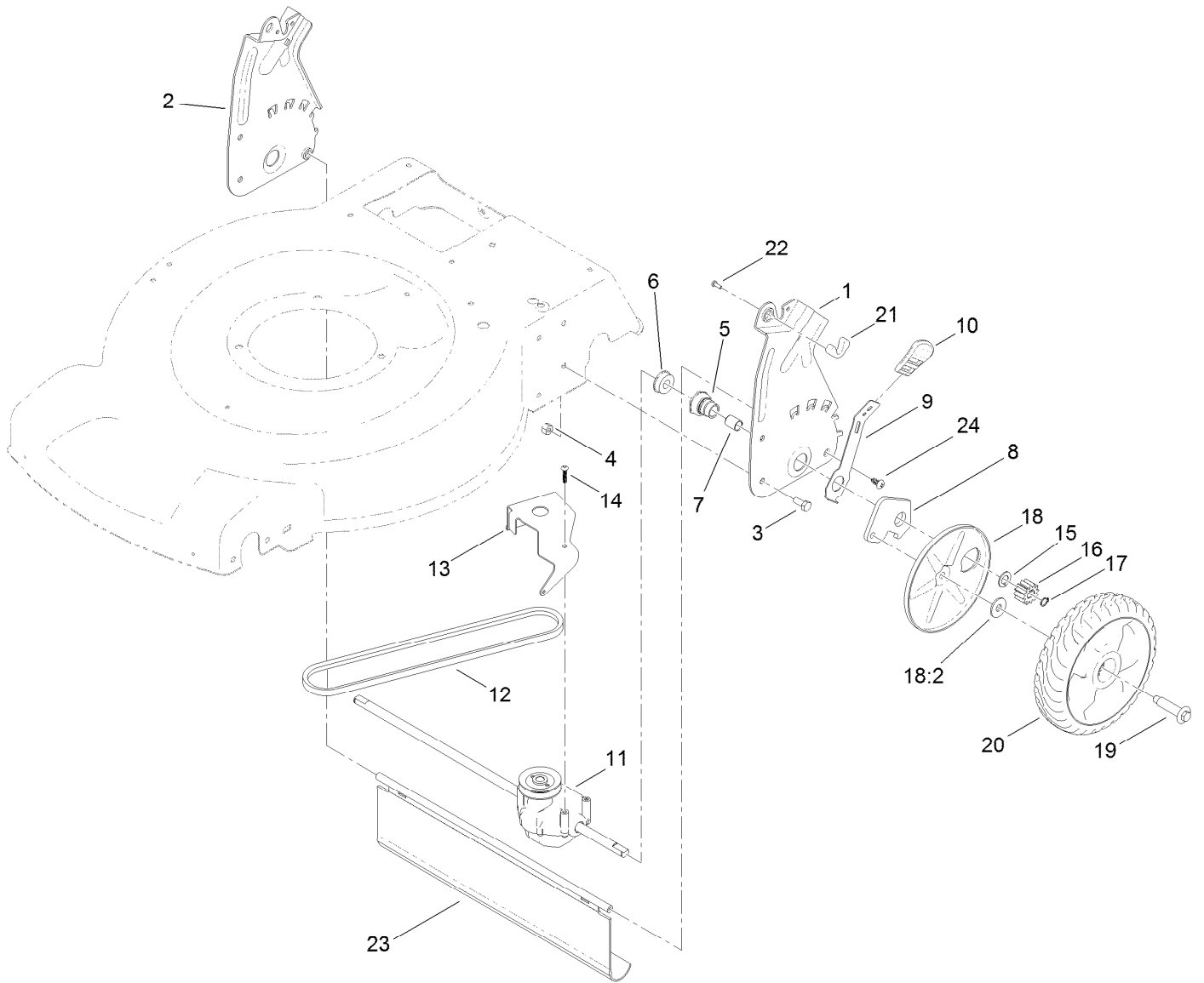

## Transmission and Rear Wheel Drive Assembly

Ref.	Part Number	Qty.	Description
1	114-7955-03	1	Plate-Rear, LH (HOC)
2	114-7956-03	1	Plate-Rear, RH (HOC)
3	322-3	4	Screw-HH
4	3296-29	4	Nut-Lock, NI
5	108-9779	2	Retainer-Bushing, HOC
6	104-8699	2	Bearing-Ball
7	108-9782	2	Bushing-Sleeve
8	108-9781	2	Arm-Pivot, Rear
9	108-9780	2	Arm-Spring
10	110-0549	2	Knob-HOC
11	115-4652	1	Transmission
12	115-4669	1	Belt-V
13	114-7977-03	1	Bracket-Transmission

Ref.	Part Number	Qty.	Description
14	108-7476	3	Screw-Plastite
15	110-7191	2	Washer-Thrust
16	115-4668	2	Gear-Pinion, 12T
17	32151-61	2	Ring-Retaining
18	110-1792	2	Wheel Cover ASM
18:2	614426	1	Washer-Stepped
19	614650	2	Bolt-Shoulder
20	115-4695	2	8 Inch Wheel Gear ASM
21	115-8406	2	Anchor-Bag
22	105-9437	2	Screw-PPH
23	115-2893	1	Shield-Trailing
24	117-1092	2	Screw-PTH

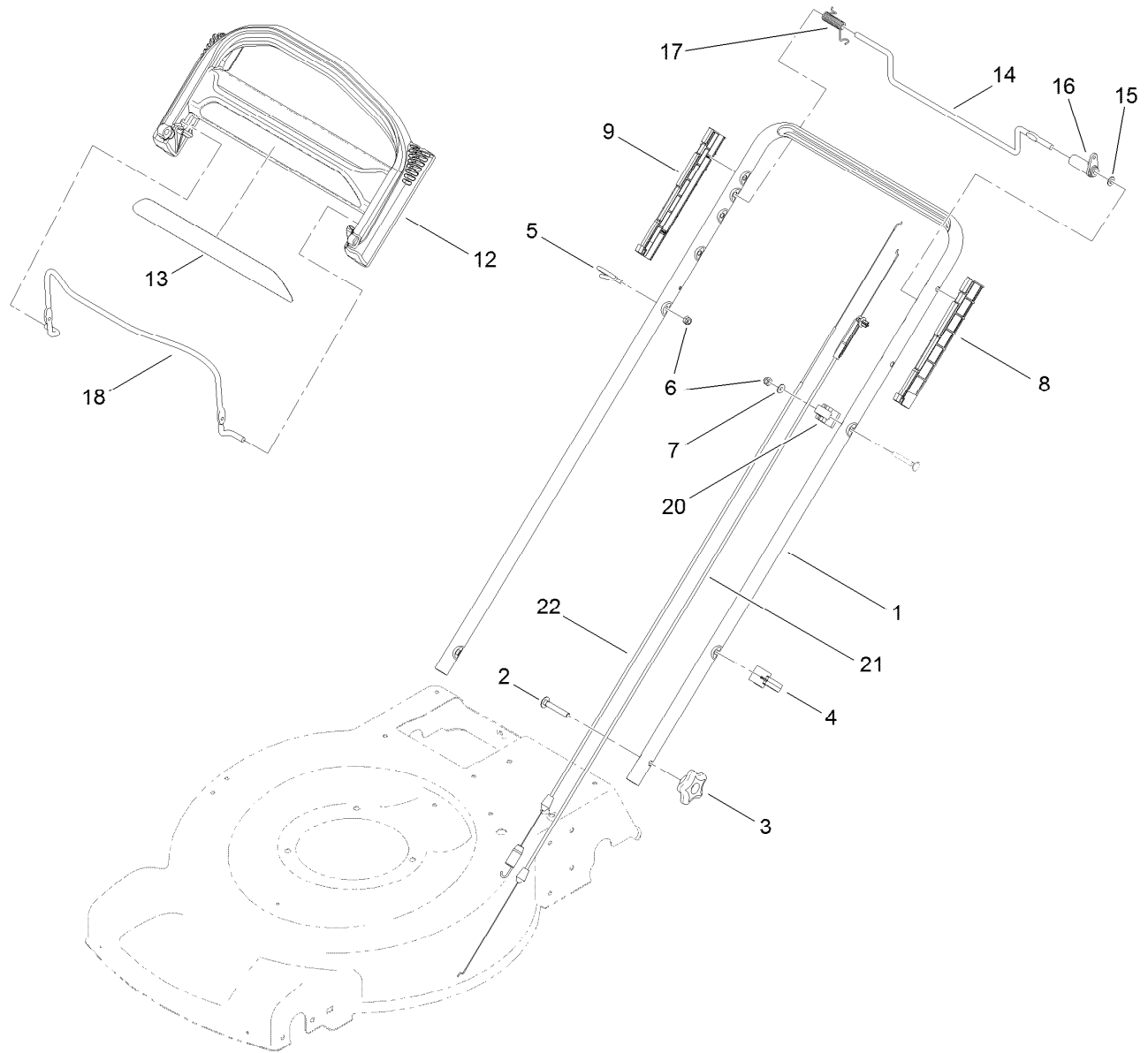

## Handle Assembly

<i>Ref.</i>	<i>Part Number</i>	<i>Qty.</i>	<i>Description</i>	<i>Ref.</i>	<i>Part Number</i>	<i>Qty.</i>	<i>Description</i>
1	119-3810-05	1	Handle	13	117-1019	1	Decal
2	3230-6	2	Screw-CARR	14	99-1588	1	Bar-Control, Traction
3	117-5976	2	Knob-Handle, Locking	15	3256-23	1	Washer-Flat
4	114-7988	1	Guide-Cable	16	99-1589	1	Lever-Traction
5	86-9671	1	Guide-Rope	17	104-8690	1	Spring-Torsion
6	3296-73	2	Nut-Lock, NI	18	104-8679-03	1	Bail-Brake
7	3256-1	1	Washer-Flat	20	99-5239	1	Anchor-Cable
8	105-6842	1	Guide-LH	21	115-8437	1	Cable-Brake
9	105-6841	1	Guide-RH	22	115-8435	1	Cable-Traction
12	104-8678	1	Handle-Control				

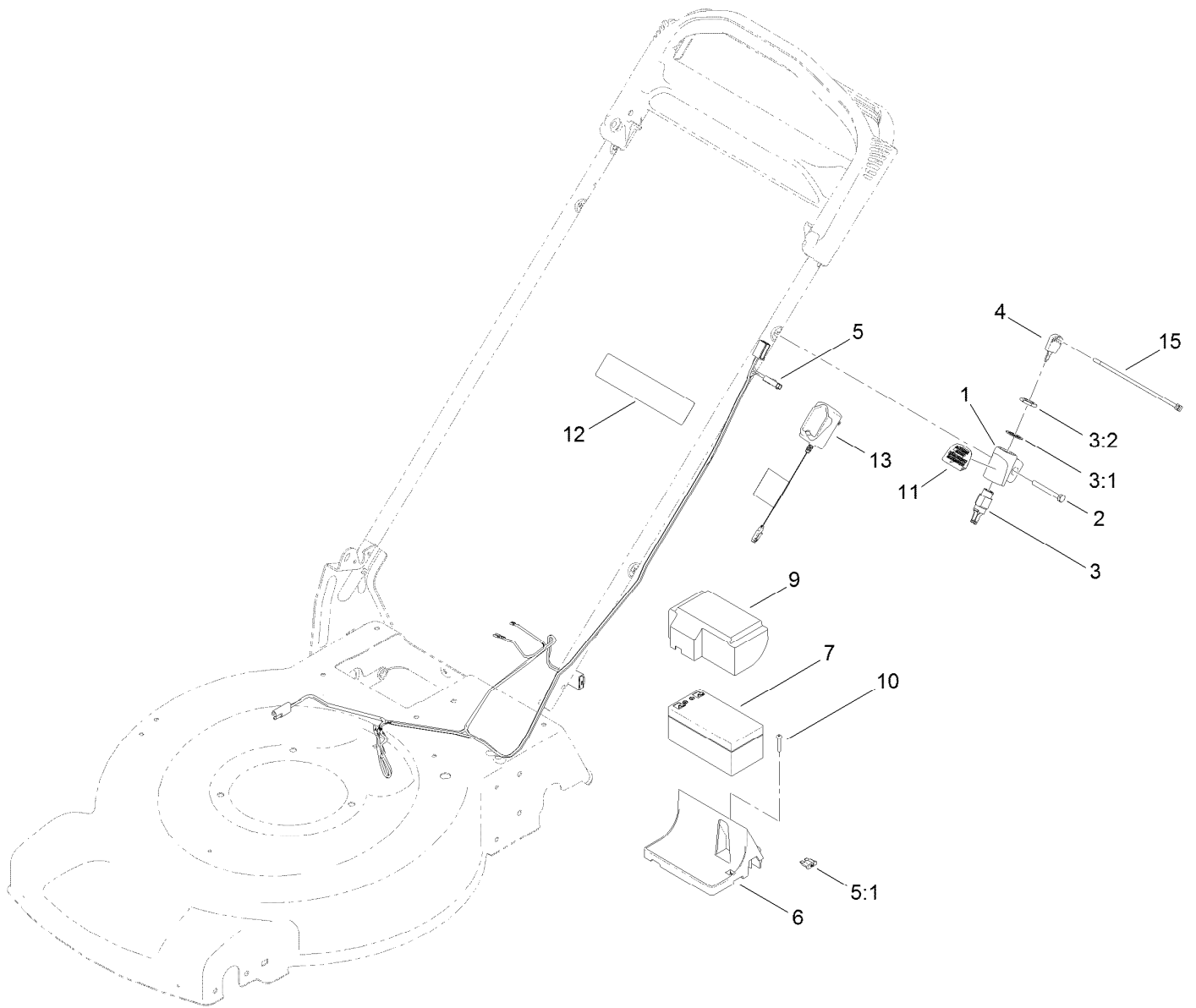

## Electrical Assembly

<i>Ref.</i>	<i>Part Number</i>	<i>Qty.</i>	<i>Description</i>
1	120-5242	1	Mount-Switch
2	92-2270	1	Screw-Handle
3	46-5780	1	Starter Switch ASM
3:1	3254-5	1	Washer-Tooth, Internal
3:2	218-461	1	Nut-HH
4	700918	1	Key
5	120-7035	1	Harness-Wire
5:1	99-6124	1	Fuse-Blade, 40 Amp

<i>Ref.</i>	<i>Part Number</i>	<i>Qty.</i>	<i>Description</i>
6	114-7936	1	Tray-Battery
7	106-8397	1	Battery-12 Volt
9	120-3329	1	Cover-Battery
10	32144-97	1	Screw-PPH, Plastite
11	114-2619	1	Decal-Electric Start
12	104-7953	1	Decal
13	114-1588	1	Charger-Battery
15	614249	3	Tie-Cable

# Attachments and Accessories

## For 20334 22in Recycler Lawn Mower

<b>Product Name</b>	<b>Model/Part</b>
Traction Assist Handle Kit.....	108-8120
Loose Parts Kit .....	117-4134
Replacement Bag .....	59310
Replacement Frame and Bag Kit.....	59312
22in Blade Kit.....	59534



**Count on it.**