

Owners Manual

Product Code: 2063T

**MADE FOR THE
TRADE**

TQ TRADEQUIP
the trusted brand in equipment

**1,000 KG
TRANSMISSION LIFTER**



Specifications

- Safe Working Capacity: RWD/FWD/AWD/4X4
GVM <3,200KG
- Rated Capacity: 1000kg
- Platform Lift Range: 950-1930mm (Excludes
60mm upright support brackets)
- Lifting Platform Size: 160x145mm (475x465mm
Max.)
- Forward Tilt: 11°
- Rearward Tilt: 11°
- Side Tilt: 9°
- Side Tilt: 11°
- Gross Weight: 82.5kg



About the **TradeQuip** brand

The '**TradeQuip**' brand of workshop equipment, is designed for use in a demanding workshop environment by professional users. With proven and trusted "Made for the Trade" reliability, '**TradeQuip**' branded products offer the very best in performance for an affordable price. All backed by a 1year trade guarantee across 1,000+ distributors Australia wide.

TQ TRADEQUIP
the trusted brand in equipment

Made in China to TQB Brands Pty Ltd specifications
Visit us at www.tqbbrands.com.au

WARNING

IMPORTANT: READ ALL INSTRUCTIONS BEFORE USE



WARNING

The instructions and warnings contained in this manual should be read and understood before using or operating this equipment. Do not allow anyone to use or operate this equipment until they have read this manual and have developed a thorough understanding of how this equipment works. Failure to observe any of the instructions contained in the manual could result in severe personal injury to the user or bystanders, or cause damage to the equipment and property. Keep this manual in a convenient and safe place for future reference.

Whilst every effort has been made to ensure accuracy of information contained in this manual, the TQB Brands Pty Ltd policy of continuous improvement determines the right to make modifications without prior warning.

CONTENT

WARNING..... 2

CONTENT 2

STANDARD OPERATING PROCEDURE 3

ASSEMBLY, OPERATION, PREVENTITIVE MAINTENANCE..... 4

TROUBLESHOOTING 7

PARTS LIST..... 8

PARTS LIST DIAGRAM 9

PARTS DRAWING..... 10

PRODUCT INFORMATION TIPS 10

WARRANTY 12



USE THIS PRODUCT FOR ITS INTENDED PURPOSE ONLY

INTENDED USE

Designed for the removal, installation, and transportation (in the lowered position) of passenger vehicle transmissions that are raised by an in-ground or above-ground lift.

STANDARD OPERATING PROCEDURE

DO NOT use this machine unless you have been trained and assessed to a competent level in its safe use and operation, and have been given permission to use this



Safety glasses must be worn when operating this equipment



Long loose hair must be contained when operating this equipment



Safety footwear must be worn when operating this equipment



Close fitting/protective clothing must be worn when operating this equipment



Rings and jewellery must not be worn when operating this equipment

PRE-OPERATING SAFETY CHECKS

Save these instructions. For your safety, read, understand, and follow the information provided with and on this **1000kg Telescopic Transmission Lifter** before using.

- DO NOT exceed the maximum lifting load capacity of 1,000kg.
- Only use this transmission lifter on a surface that is stable, level, smooth, dry and capable of sustaining the load. Keep the surface free from unrelated materials and ensure that there is adequate lighting.
- DO NOT use on tarmac, or any other soft surface as the transmission may sink or topple.
- Vehicle must be properly and adequately supported before commencing work with this transmission lifter.
- This transmission lifter is used as an aid in the removal and installation of a transmission or a differential as individual components. DO NOT use it for any other purpose than it is designed for.
- Always centre the load on the saddle of this transmission lifter and be sure the transmission is stable and secure before raising or lowering.
- DO NOT use the transmission lifter to lift or support a heavy load such as a differential with axle or a transmission with bell housing which is bulky and difficult to balance, and may cause the transmission lifter to tip over and lead to equipment damage and/or serious personal injury.
- Never move this transmission lifter with a load any higher off the ground than necessary and always move it slowly and carefully.
- Transfer the load immediately to appropriate support device for service or repair.
- DO NOT operate this transmission lifter when you are tired or under the influence of alcohol, drugs or any intoxicating medication.
- DO NOT allow untrained persons to operate this product and DO NOT make any modifications to this product.
- DO NOT tamper with the safety valve.
- DO NOT use brake fluid or any other improper fluid to refill or top up the hydraulic system of this transmission lifter. Only use good quality hydraulic jack oil.
- DO NOT expose the transmission jack to rain or any other kind of inclement weather.
- Use a qualified person to maintain the transmission lifter in good condition. Keep the transmission lifter clean for best and safest performance.
- Use approved personal protection safety equipment such as eye protection, non skid boots, full face impact shield and heavy duty work gloves. Keep proper footing and balance, do not overreach.



WARNING:

Vehicle must be properly and adequately supported before commencing work with this Transmission Lifter.

INTENDED USE

Designed for the removal, installation, and transportation (in the lowered position) of 4WD and light commercial transmissions that are raised by an in-ground or above-ground lift. Not designed for supporting loads.

ASSEMBLY, OPERATION, PREVENTITIVE MAINTENANCE

1. FEATURES

This *TradeQuip "Made for the Trade"* 1,000kg Transmission Lifter is designed for transmission installation and removal. It features a universal mounting cradle that provides a wide fore and aft tilt range and a manually operated hydraulic system with smooth hydraulic lift and descent. The hydraulic system also includes a bypass system to prevent over extension and accidental overloading. The sturdy and stable design offers safety and security when removing and installing large and heavy transmissions.

This 2-stage telescopic transmission lifter offers a wide range of versatility that will help increase workshop productivity. Designed to accommodate both large and small transmissions, this handy piece of equipment is ideal for use with 4WD and light truck transmissions. The wide base is enhanced by the additional strut arms and heavy-duty steel swivel castors for easy maneuvering throughout the workshop under load.

2. ASSEMBLY

Unpack the product and check contents with the exploded drawing and the parts list. Should there be any damaged or missing parts, contact your place of purchase immediately.

1. Put two leg assemblies (9) upside down, attach them together using bolts (10), washers (5), lock washers (6) and nuts (4). Then turnover to normal upright position, fit the four castors (7) to the legs using washers (3), lock washers (2) and nuts (8).
2. Put the jack main body onto the centre of the legs and tighten using washers (3), lock washers (2) and bolts (1).
3. Attach the mounting brackets (18) to the jack's main body using bolts (18), washers (6), lock washers (5) and nuts (4).
4. Attach the side supports (12) to the mounting bracket and leg assembly using bolt (11), washers (5) and nuts (4).
5. Screw the saddle kit (19) onto the top of the piston rod, then assemble the adaptor as per the exploded drawing.



OPEN BREATHER VALVE BEFORE USE

3. BEFORE USE

Ensure Breather Valve is open before use.

Prior to use conduct a visual inspection checking for abnormal conditions, such as cracked welds, leaks, and damaged, loose, or missing parts.

1. Following assembly and before first use leave the jack for one hour to allow the oil to settle before purging the system.
2. Loosen the air vent screw (16)
3. Bleed the hydraulic system to eliminate any air in the system by pushing down the foot operated release pedal (13) and pumping the foot operated lift pedal (14) 15-20 times.
4. Test the jack without load by raising it to full height and then lowering the jack. Open the release valve by pushing the release foot pedal (13) down gently to control the rate of descent.

4. OPERATION

1. Always loosen the air vent screw (16) before use.
2. Roll the transmission lifter into position and pump the lift foot pedal (14) until the transmission adaptor reaches the desired height. **NOTE:** Follow the vehicle manufacturer's recommended procedures for removing the load as outlined in the vehicle service manual or repair guide.
3. Carefully centre the load on the saddle. Ensure the load's centre of gravity is centred on the saddle and the transmission is stable and secure. Use the chains to secure the load. **NOTE:** Before lowering the load check to ensure all tools and personnel are clear and it is safe to lower the load.
4. SLOWLY and CAREFULLY push the release foot pedal (13) to lower the load to its lowest position. **NOTE:** The speed of lowering is controlled by pressure on the release valve. The more the valve is opened the more rapidly the jack descends. Ensure the decent is slow and controlled.



WARNING: Dangerous dynamic shock loads are created by quick opening and closing the release valve when the load is being lowered. The resulting overload may cause hydraulic system failure which could cause property damage and/or severe personal injury.

5. Once the load is lowered, CAREFULLY and SLOWLY move the transmission lifter.
6. Transfer load immediately to appropriate support device for service or repair.
7. When work is complete, lower the saddle to its lowest position and tighten the air vent screw.

5. INSPECTION

- Prior to each use conduct a visual inspection checking for abnormal conditions, such as cracked welds, leaks, damaged, loose, or missing parts.
- The transmission lifter shall be maintained in accordance with the maintenance instructions. No alterations or modifications shall be made to this transmission lifter.
- Inspections shall be performed in accordance with this owner's manual.
- The transmission lifter must be inspected immediately if it is believed to have been subjected to abnormal load or shock.
- Owners and /or operators should be aware that repair of this product may require specialised equipment and knowledge (refer to maintenance section).

6. STORAGE

This transmission lifter should always be stored in a dry location on a level surface with the saddle fully lowered and the air vent valve closed.

7. MAINTENANCE

Replace or repair damaged parts. Use recommended parts only. Non-authorized parts may be dangerous and will invalidate the warranty.

1. The hydraulic system is closed and will normally require no maintenance.
2. The mechanical parts of the transmission lifter, such as the pedal and release should be occasionally lubricated with heavy oil or grease.
3. Protect the transmission lifter cylinder from dirt or grit, when in the raised position. If it becomes dirty, wipe off with a clean cloth.
4. Maintain and store the transmission lifter in a protected environment. Do not expose to rain or excess moisture.
5. Clean the transmission lifter with clean water and a damp cloth. Do not use a pressure washer near the seal, piston or valves. Lubricate following cleaning.
6. If the transmission lifter allows a load to slowly lower on its own, you may have insufficient lifter oil or worn/damaged seals.
 - Check oil level. If the oil level is OK, contact an authorised repair facility.
 - Damaged seals may be caused by overloading, or exposure to harmful condition or inappropriate use of a pressure washer.

Note: If the transmission lifter can be pumped up to its highest position, it indicates that there is enough oil. If the lifter fades from this position, it indicates that the problem is likely the seals.

7. To check the oil level, be sure the lifter is in its lowest position. Remove the oil filler plug. The oil level should be at the bottom of the filler plug hole. You can visually see the oil, or test with your finger. If the oil level is low, add good quality hydraulic lifter oil ISO VG32.

Important: Dirt is the greatest single cause of failure in hydraulic units. Keep the transmission lifter clean and well lubricated to prevent foreign matter from entering the system.

Pivots and pins in all manual pump and release mechanisms should be lubricated with a Light Bearing Grease or 30/40W Machine Oil to ensure long life and prevent premature wear.



Wheel axles and Castor ball races should be lubricated with a Light Bearing Grease or 30/40W Machine Oil to ensure long life and prevent premature wear.

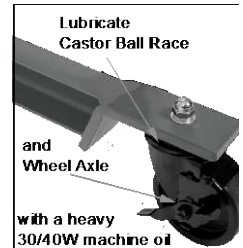

Cradle Pins, Pivots and Threaded Adjustor Rods should be lubricated with a Light Bearing Grease or 30/40W Machine Oil to ensure long life and prevent premature wear.

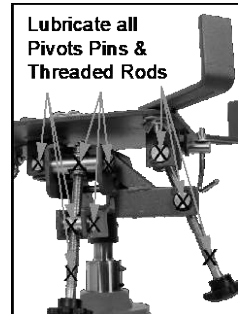

Pedal Type Release Mechanisms should be lubricated with a light bearing grease or 30W/40W Machine Oil.

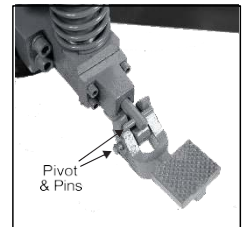

If the transmission lifter has been exposed to rain, snow, sand, or grit it must be cleaned before it is stored or used.

Periodically check the piston rod for signs of rust or corrosion. Clean exposed areas with a clean oiled cloth.



WARNING: Never use sandpaper or abrasive material on these surfaces.

8. SERVICE & REPAIR

Any Transmission Lifter found damaged in any way or found to be worn or operates abnormally it should be removed from service until repaired by an authorised service agent. Owners and / or operators should be aware that repair of this product may require specialised equipment and knowledge. Only authorised parts, labels, decals shall be used on this equipment. Annual inspection of the transmission lifter is recommended and can be made by an authorised repair facility to ensure that your equipment is in optimum condition and that the equipment has the correct decals and safety labels specified by the manufacturer.

TROUBLESHOOTING

Problem	Symptom	Cause	Conclusion	Solution
Lifter will not lift using foot pump	Pump has no resistance, lift ram will not raise	Release pedal valve pin obstructed Air in hydraulic system Load weight exceeds lift capacity Pump circuit protection valve actuated Overload actuated	Valve seat/check ball failure. Air cavitation in pump and/or lift ram Higher capacity lifter required Pump circuit protection valve needs reset Relief valve needs reset	Clean mechanism, bleed system, ensure all fasteners are tight. Bleed system as per instructions Select higher capacity lifter Depress release pedal, valve will reset Contact qualified technician for repairs
Lifter will not hold load	Load cannot be sustained, lift ram drops under load Pump pedal rises	Release valve unable to close External Leak at lift ram. Damaged main seal Main check valve obstructed	Valve shaft misaligned Transmission lifter operated with breather closed for extended period causing air ingress to hydraulic system and reservoir pressurisation. Replace main ram seals Replace main check valve ball and reseal valve seat	Contact qualified technician for repairs With ram fully retracted, open the breather to let pressurised air escape, Bleed system. Contact qualified technician for repairs
Lifter will not lower after unloading	Lift ram rises after retracting Lift ram will not retract	Reservoir overfilled and breather closed Breather closed	Ram failure due to reservoir pressurised caused by excess reservoir level and closed breather valve Breather closed causing hydraulic lock	Fully retract ram and drain excess oil and bleed system as per instructions Open breather and bleed system Contact qualified technician for repairs
Poor lift performance	Pump has no resistance, lift ram will not raise to full stroke	Fluid level low Air trapped in system breather closed, pump failure due to cavitation caused by air pressure build up in reservoir	Fill fluid to correct level Lift ram raised for extended period causing air ingress to hydraulic system	Fill fluid to correct fluid level and bleed system With ram fully retracted, open the breather to let pressurised air escape bleed system Contact qualified technician for repairs

PARTS LIST

Part#	Description	QTY	Part#	Description	QTY
1	Secondary Ram	1	38	Piston	1
2	Snap ring	1	39	Spring	1
3	O-ring	1	40	Spring cover	1
4	Seal ring	1	41	Shaft ring	2
5	Nut	1	42	Cross beam	1
6	O-ring	1	43	Screw	1
7	Seal ring	1	44	Steel ball	1
8	O-ring	1	45	O-ring	1
9	Seal Ring	1	46	Release valve core	1
10	Screw	1	47	Spring	1
11	Steel ball	1	48	Release valve seat	1
12	Primary Ram	1	49	Pin	1
13	Snap ring	1	50	Shaft pin	1
14	Cap	1	51	Release pedal	1
15	Nut	11	52	Screw	4
16	Lock washer	8	53	Lock washer	4
17	Support bracket	1	54	Lift pedal	1
18	Bolt	8	55	Flat Washer	2
19	Bolt	1	56	Cotter pin	2
20	R-pin	2	57	Pin	1
21	Seal ring set	1	58	Pin	2
22	Air vent screw	1	59	Circlip	2
23	Shaft pin	1	60	Link	2
24	Ram assembly	1	61	Base (left leg)	1
25	Handle tube	1	62	Base (right leg)	1
26	Handle sleeve	1	63	Bolt	6
27	Plug screw	1	64	Washer	6
28	O-ring	2	65	Adjustable bolt	4
29	Spring	1	66	Nut	4
30	Steel ball	1	67	Support bar	4
31	Screw	4	68	Nut	4
32	Pump assembly	1	69	Flat Washer	4
33	Copper washer	1	70	Caster	4
34	Piston seat	1	71	Copper washer	1
35	Shaft ring	1	72	Lock washer	4
36	Seal ring	1	73	Steel ball	1
37	Washer	1			

PARTS LIST DIAGRAM

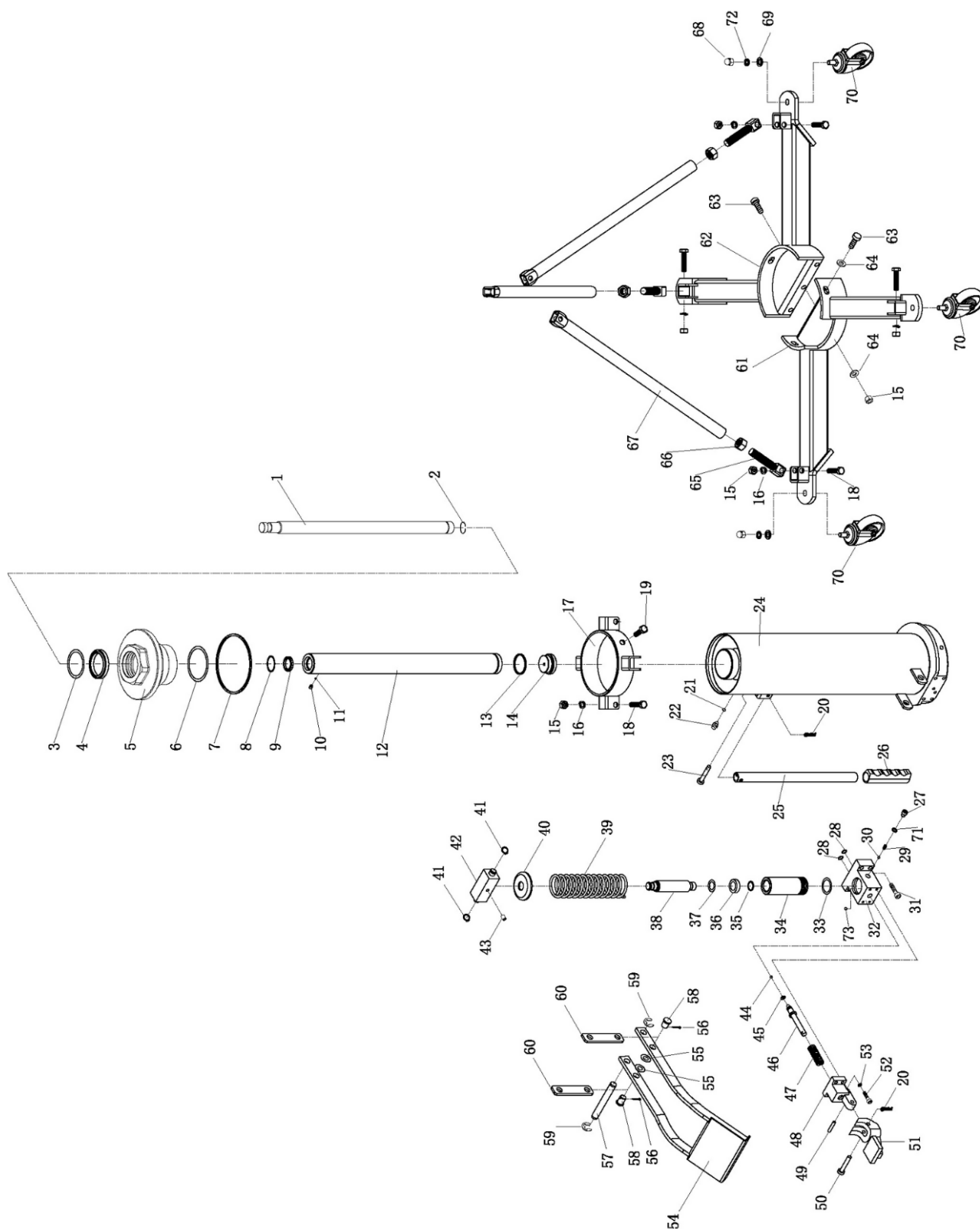

PARTS DRAWING

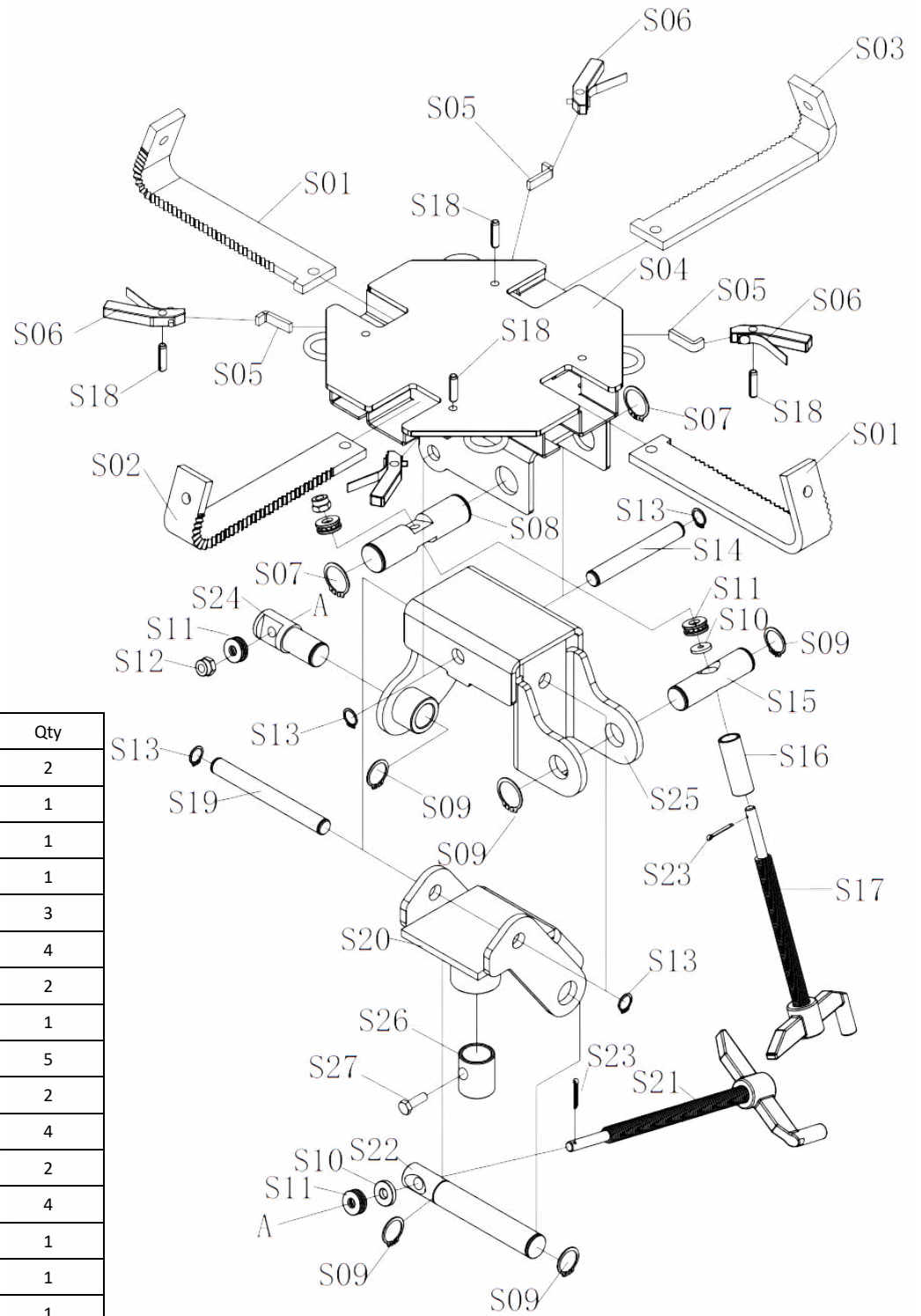

Part#	Description	Qty
S01	Safety Block 1	2
S02	Safety Block 2	1
S03	Safety Block 3	1
S04	Saddle Plate	1
S05	Limited Lock	3
S06	Safety Limit Assembly	4
S07	Retainer Ring	2
S08	Pin	1
S09	Retainer Ring	5
S10	Support Plate	2
S11	Bearing	4
S12	Nut	2
S13	Retainer Ring	4
S14	Connection Axle 2	1
S15	Pin	1
S16	Limited Tube	1
S17	Handle 2	1
S18	Pin	4
S19	Connection Axle 1	1
S20	Saddle Seat	1
S21	Handle 1	1
S22	Pin	1
S23	Cotter Pin	2
S24	Pin Assembling Seat	1
S25	Welded Saddle Seat	1
S26	Sleeve	1
S27	Bolt	1

PRODUCT INFORMATION TIPS

PRODUCT INFORMATION

How to extend the life of your Transmission Lifter

10 Top Tips

to extend the life of your TQB BRANDS Transmission Lifter

1 Open the breather valve prior to use.

Opening the breather prior to operation ensures the efficient hydraulic operation of the lift ram and pump preventing pump and ram cavitation resulting in poor operation and or possible hydraulic oil loss.



2 Regularly lubricate the tilt adjust rods, pivot points.

Lubrication of all pivots, pins, adjusters, and castor wheels ensures smooth operation during lifting and adjustment procedures while removing a transmission.



3 Regularly lubricate the castors axles & ball races to ensure smooth movement of the loaded jack.



4 Always store in the fully lowered position.

Storage in the lowered position ensures the lift ram assembly is sealed from exposure to weather fluctuations and keeps the hydraulic ram seals in a relaxed condition ready to work when required.



5 Never use trans lifter for supporting loads.

To ensure long life of the hydraulic lift ram seals, a load must not be supported above the fully lowered position. Once a transmission is removed from a vehicle the loaded transmission lift must be fully lowered where the internal mechanical travel stops can support the load. Transmission lifts must not be used for suspension support during repairs. Please use a suitable auxiliary stand for this purpose.



6 Centering the load on the platform.

Correct balance of the load is a critical factor where unbalanced loads can affect the smooth lowering and raising operation. Always consult your vehicle manufacturer specifications for the correct lift point when attaching transmission lifter to a transmission.



7 Use correct model for intended application.

The following chart explains model suitability based on GVM and Transmission type.

TQB BRANDS Recommendation for Under Hoist Transmission Jack Applications							
	GVM LESS THAN 2000KG	GVM LESS THAN 2300KG	GVM LESS THAN 2500KG	GVM LESS THAN 3200KG	GVM LESS THAN 3500KG	2 WHEEL DRIVE	ALL WHEEL DRIVE 4 X 4 LIGHT & COMMERCIAL
2049T/59T	Y					Y	
2002T/22T	Y	Y				Y	Y
2052	Y	Y	Y			Y	Y
PROTL500	Y	Y	Y			Y	Y
2053T/63T	Y	Y	Y	Y		Y	Y
PROTL1000	Y	Y	Y	Y	Y	Y	Y

8 Hazards and Obstructions.

All wheeled TQB Brands equipment must be used on smooth surface free of cracks, crevices and tripping hazards that can foul the wheels during operation or relocation.

9 Read the user Manual thoroughly and keep a copy easily accessible.

The user's manuals are important to the initial set up and ongoing maintenance and come with each transmission jack, they are also downloadable from our webpage at www.tqbbrands.com.au

10 Visit our webpage for instructional videos.

We have created instructional videos for our range of transmission jacks which include bleeding procedures and product comparisons. You'll find these at www.tqbbrands.com.au



WARRANTY

TradeQuip products have been carefully tested and inspected before shipment and are guaranteed to be free from defective materials and workmanship for a period of 12 months from the date of purchase except where tools are hired out when the guarantee period is ninety days from the date of purchase.

Should this piece of equipment develop any fault, please return the complete tool to your nearest authorised warranty repair agent or contact TQB Brands Pty Ltd Warranty team – warranty@tqbbrands.com.au.

If upon inspection it is found that the fault occurring is due to defective materials or workmanship, repairs will be carried out free of charge. This guarantee does not apply to normal wear and tear, nor does it cover any damage caused by misuse, careless or unsafe handling, alterations, accident, or repairs attempted or made by any personnel other than the authorised TQB Brands Pty Ltd repair agent.

This guarantee applies in lieu of any other guarantee expressed or implied and variations of its terms are not authorised.

Your TQB Brands Pty Ltd guarantee is not effective unless you can produce upon request a dated receipt or invoice to verify your proof of purchase within the 12 month period.

Consumer Guarantee

Our goods come with a guarantee that cannot be excluded under the Australian Consumer Law. You are entitled to a replacement or refund for a major failure and compensation for any other reasonably foreseeable loss or damage. You are also entitled to have the goods repaired or replaced if the goods fail to be of acceptable quality and the failure does not amount to a major failure.



All images and illustrations shown are for reference purposes only. All information, specifications and illustrations in this manual are based on the latest information available at the time of publication and are subject to change without notice. The information in this manual is periodically revised to ensure the latest information is included. Download the latest version of this manual and other related technical documentation from www.tqbbrands.com.au.