

Owners Manual

Product Code: 2068T

**MADE FOR THE
TRADE**

TQ TRADEQUIP
the trusted brand in equipment

AUXILIARY LIFTER KIT

Specifications

- Rated Capacity: 500KG
- Working Height: 1175-1985 mm
- Lifting Platform Size:
 - A: 362x362mm
 - B: Φ 107mm
 - C: 812x352mm



About the TradeQuip brand

The 'TradeQuip' brand of workshop equipment, is designed for use in a demanding workshop environment by professional users. With proven and trusted "Made for the Trade" reliability, 'TradeQuip' branded products offer the very best in performance for an affordable price. All backed by a 1 year trade guarantee across 1,000+ distributors Australia wide.

TQ TRADEQUIP
the trusted brand in equipment

TQ PRO
Trusted by serious professionals

BORUM
INDUSTRIAL WORKSHOP EQUIPMENT

Made in China to TQB Brands Pty Ltd specifications

Visit us at www.tqbbrands.com.au

WARNING

IMPORTANT: READ ALL INSTRUCTIONS BEFORE USE



The instructions and warnings contained in this manual should be read and understood before using or operating this equipment. Do not allow anyone to use or operate this equipment until they have read this manual and have developed a thorough understanding of how this equipment works. Failure to observe any of the instructions contained in the manual could result in severe personal injury to the user or bystanders, or cause damage to the equipment and property. Keep this manual in a convenient and safe place for future reference.

Whilst every effort has been made to ensure accuracy of information contained in this manual, the TQB Brands Pty Ltd policy of continuous improvement determines the right to make modifications without prior warning.

CONTENT

WARNING 2

CONTENT 2

STANDARD OPERATING PROCEDURE 3

ASSEMBLY, OPERATION, PREVENTITIVE MAINTENANCE..... 4

TROUBLESHOOTING 7

PARTS LIST 8

PARTS LIST DIAGRAM 9

WARRANTY 10

- **Do not force the product. Products are safer and do a better job when used in the manner for which they are designed. Plan your work and use the correct product for the job.**
- **Be aware of dynamic loading. A sudden loading movement may briefly create an excess load causing product failure.**



USE THIS PRODUCT FOR ITS INTENDED PURPOSE ONLY

INTENDED USE

For partial temporary support of vehicle components during removal and installation of components. Bracket C as shown on the front for removal and installation of fuel tanks only.

STANDARD OPERATING PROCEDURE

DO NOT use this machine unless you have been trained and assessed to a competent level in its safe use and operation, and have been given permission to use this



Safety glasses must be worn when operating this equipment



Long loose hair must be contained when operating this equipment



Safety footwear must be worn when operating this equipment



Close fitting/protective clothing must be worn when operating this equipment



Rings and jewellery must not be worn when operating this equipment

PRE-OPERATING SAFETY CHECKS

Save these instructions. For your safety, read, understand, and follow the information provided with and on this **500kg AUXILIARY LIFTER KIT** before using.

- DO NOT exceed the maximum lifting load capacity of 500kg.
- Only use this Auxiliary Lifter Kit on a surface that is stable, level, smooth, dry and capable of sustaining the load. Keep the surface free from unrelated materials and ensure that there is adequate lighting.
- DO NOT use on tarmac, or any other soft surface as the support stand may sink or topple.
- Vehicle must be properly and adequately supported before commencing work with this Auxiliary Lifter Kit.
- This Auxiliary Lifter Kit is used as an aid in the removal and installation of individual components. DO NOT use it for any other purpose than it is designed for.
- Always centre the load on the saddle of this support stand and be sure the component is stable and secure before raising or lowering.
- DO NOT use the Auxiliary Lifter Kit to lift or support a heavy load such as a differential with axle or a transmission with bell housing which is bulky and difficult to balance and may cause the support stand to tip over and lead to equipment damage and/or serious personal injury.
- Never move this Auxiliary Lifter Kit with a load any higher off the ground than necessary and always move it slowly and carefully.
- Transfer the load immediately to appropriate support device for service or repair.
- DO NOT operate this Auxiliary Lifter Kit when you are tired or under the influence of alcohol, drugs or any intoxicating medication.
- DO NOT allow untrained persons to operate this product and DO NOT make any modifications to this product.
- DO NOT tamper with the safety valve.
- DO NOT use brake fluid or any other improper fluid to refill or top up the hydraulic system of this transmission lifter. Only use good quality hydraulic jack oil.
- DO NOT expose the Auxiliary Lifter Kit to rain or any other kind of inclement weather.
- Use a qualified person to maintain the transmission lifter in good condition. Keep the support stand clean for best and safest performance.
- Use approved personal protection safety equipment such as eye protection, non skid boots, full face impact shield and heavy duty work gloves. Keep proper footing and balance, do not overreach.



WARNING:

Vehicle must be properly and adequately supported before commencing work with this product.

INTENDED USE

This Auxiliary Lifter is used as an aid in the removal and installation of individual components. Bracket C as shown on the front for removal and installation of fuel tanks only.

ASSEMBLY, OPERATION, PREVENTITIVE MAINTENANCE

1. FEATURES

This *TradeQuip "Made for the Trade"* 500kg Auxiliary Lifter is the perfect under hoist aid during removal and installation of small components. It features a mounting cradle and lift pad and a manually operated hydraulic system with smooth hydraulic lift and descent. The hydraulic system also includes a bypass system to prevent over extension and accidental overloading. The unit includes a bracket designed for use for Fuel Tank Removal only.

NOT INTENDED FOR SUPPORTING LOADS

NOT INTENDED AS STAND ALONE TRANSMISSION LIFTER

2. ASSEMBLY

Unpack the product and check contents with the exploded drawing and the parts list. Should there be any damaged or missing parts, contact your place of purchase immediately.

1. Attach the two legs (67) to the base (33) using bolts (63) and lock washer (62) washer (61).
2. Fit the four castors (68) to the legs (67) using nuts (64) and washers (65).
3. Put the saddle (25) onto the top of the piston rod (26) and slip it down.



OPEN BREATHER VALVE BEFORE USE

3. BEFORE USE

Ensure Breather Valve is open before use.

Prior to use conduct a visual inspection checking for abnormal conditions, such as cracked welds, leaks, and damaged, loose, or missing parts.

1. Leave the Auxiliary Lifter Kit for one hour to allow the oil to settle before purging the system. **NOTE:** Failure to allow sufficient time for the oil to settle could result in air remaining in the oil. In this event, the jack will not purge completely first time and a second purge will be required.
2. Loosen the air vent screw (22)
3. Purge the hydraulic circuit to eliminate any air in the system by ensuring the air vent screw (22) is opened at least one full turn, holding the spring-loaded release handle (02) to the right position and then pumping the foot pedal (46) 15 to 20 times.
4. With the release handle back in the closed position, test the jack without load by raising it to full height and then lowering it. Partially opening the release valve will result in a slow and gradual descent of the load, while opening it fully allows for a faster descent.

4. OPERATION

WARNING! Ensure that you read, understand and apply the safety instructions and warnings before use. Failure to heed these instructions may result in property damage and/or personal injury.

- **Do not force the product. Products are safer and do a better job when used in the manner for which they are designed. Plan your work and use the correct product for the job.**
- **Be aware of dynamic loading. A sudden loading movement may briefly create an excess load causing product failure.**
 1. Roll the Auxiliary Lifter Kit into position and pump the foot pedal (46) until saddle (25) reaches desired height.
NOTE: Follow vehicle manufacturer's recommended procedures for removing the load as outlined in vehicle service manual or repair guide.
 2. Carefully center load on the saddle. Ensure the load's center of gravity is centered on the saddle and the setup is stable

and secure.

NOTE: Before lowering load check to ensure all tools and personnel are clear and it is safe to lower the load.

3. **SLOWLY** and **CAREFULLY** turn the release handle (02) to the right to lower the load to its lowest possible position.

NOTE: The speed of lowering is controlled by the release handle. The more the valve is opened the more rapidly the jack descends. Ensure the decent is slow and controlled. **WARNING!** Dangerous dynamic shock loads are created by quick opening and closing the release handle when the load is being lowered. The resulting overload may cause hydraulic system failure which could cause property damage and/or severe personal injury.

4. If necessary, **CAREFULLY** and **SLOWLY** move the support stand.
5. Transfer load immediately to appropriate support device for service or repair.

NOTE: The speed of lowering is controlled by pressure on the release valve. The more the valve is opened the more rapidly the jack descends. Ensure the decent is slow and controlled.



WARNING: Dangerous dynamic shock loads are created by quick opening and closing the release valve

5. INSPECTION

- Prior to each use conduct a visual inspection checking for abnormal conditions, such as cracked welds, leaks, and damaged, loose, or missing parts.
- The support stand shall be maintained in accordance with the maintenance instructions. No alterations or modifications shall be made to this support stand.
- Inspections shall be performed in accordance with this owner's manual.
- The support stand must be inspected immediately if it is believed to have been subjected to abnormal load or shock.
- Owners and /or operators should be aware that repair of this product may require specialised equipment and knowledge (refer to maintenance section).

6. STORAGE

This Auxiliary Lifter Kit should always be stored in a dry location on a level surface with the saddle fully lowered and the air vent valve closed.

7. MAINTENANCE

Replace or repair damaged parts. Use recommended parts only. Non-authorized parts may be dangerous and will invalidate the warranty.

1. When not in use, store the jack in a dry location with saddle in lowest position.
2. Periodically check the piston rod for signs of rust or corrosion. Clean exposed areas with a clean oiled cloth. **Warning: Never use sandpaper or abrasive material on these surfaces!**
3. A coating of light lubricating oil to pivot points, axles and hinges will help to prevent rust and assure that castors, foot pedal and pump assemblies move freely. Periodically lubricate the pivot points, axles and hinges with a light lubricating oil as needed.
4. With the jack in its lowest position, remove the air vent screw (22) to check the hydraulic oil level. If it is not adequate, add high quality hydraulic jack oil as necessary. Insert and tighten the air vent screw. Then purge away air from hydraulic system as described in 3.3. **Warning: DO NOT use brake fluid or any other improper fluid and avoid mixing different types of oil when adding hydraulic oil.**
5. To ensure best performance and longer equipment life, replace the complete hydraulic oil at least once a year. With jack in its lowest position, remove the air vent screw (22), lay the jack on its side and drain the oil into a suitable container. Ensure that no dirt gets into the system. Set the jack in its level upright position, fill with approved hydraulic jack oil. Then

replace the air vent screw (22) and purge away air from hydraulic system as described in 3.3. **Note: Dispose of hydraulic oil in accordance with local regulations.**

6. When equipment efficiency drops, purge away air from hydraulic system as described in 3.3.
7. It is recommended that an annual inspection be done by qualified technicians.

Important: Dirt is the greatest single cause of failure in hydraulic units. Keep the support stand clean and well lubricated to prevent foreign matter from entering the system.

Pivots and pins in all manual pump and release mechanisms should be lubricated with a Light Bearing Grease or 30/40W Machine Oil to ensure long life and prevent premature wear.

Wheel axles and Castor ball races should be lubricated with a Light Bearing Grease or 30/40W Machine Oil to ensure long life and prevent premature wear.

Pedal Type Release Mechanisms should be lubricated with a light bearing grease or 30W/40W Machine Oil.

If the transmission lifter has been exposed to rain, snow, sand, or grit it must be cleaned before it is stored or used.

Periodically check the piston rod for signs of rust or corrosion. Clean exposed areas with a clean oiled cloth.



WARNING: Never use sandpaper or abrasive material on these surfaces.

SERVICE & REPAIR

Any Transmission Lifter found damaged in any way or found to be worn or operates abnormally it should be removed from service until repaired by an authorised service agent. Owners and / or operators should be aware that repair of this product may require specialised equipment and knowledge. Only authorised parts, labels, decals shall be used on this equipment. Annual inspection of the transmission lifter is recommended and can be made by an authorised repair facility to ensure that your equipment is in optimum condition and that the equipment has the correct decals and safety labels specified by the manufacturer.

TROUBLESHOOTING

Trouble	Cause	Solution
Unit fails to extend or extends partially	1.Low fluid level	1.Refer to maintenance section and fill to correct fluid level (7.4)
Incomplete or spongy cylinder response when foot pedal is pumped	1.Low fluid level	1.Fill to correct fluid level(7.4)
	2.Air in system	2.Refer to maintenance section and fill to correct fluid level(3.3)
	3.Pressure is low	3.Pressure regulating again
Unit fails to extend when foot pedal is pumped	1.Release handle malfunction	1.Pump foot pedal with release handle open
	2.Contamination	2.Disassemble and clean unit
Cylinder doesn't retract or retract slow when release pedal is activated	1.Release handle malfunction or cylinder is binding	1.Disassemble unit; replace defective parts
	2.Contamination	2.Disassemble and clean unit

PARTS LIST

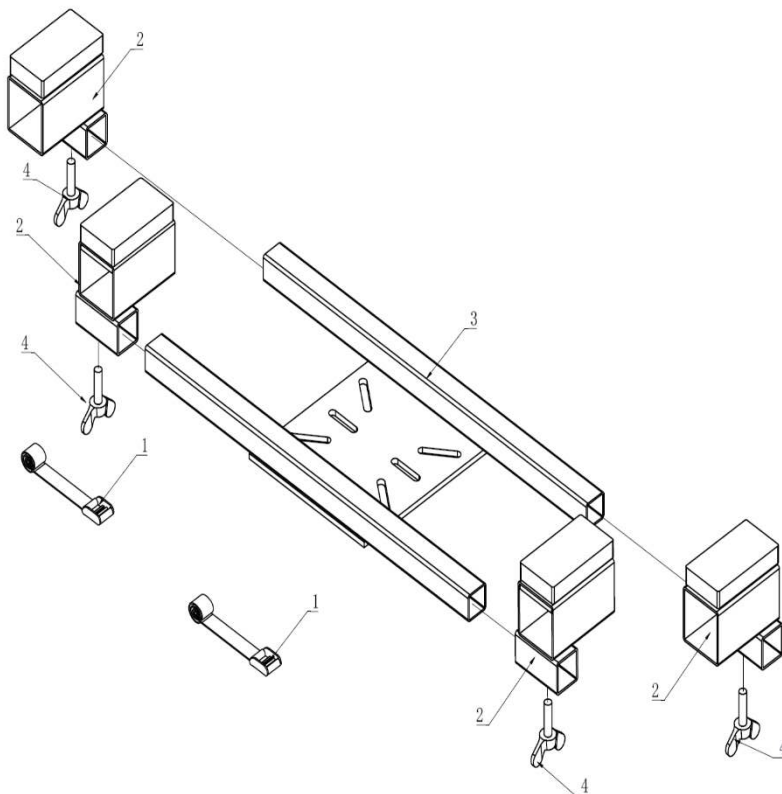

Part#	Description	Qty
1	Tie-Down Strap	2
2	Bracket Limit Assembly	4
3	Bracket Base	1
4	Thumbscrew	4

PARTS LIST

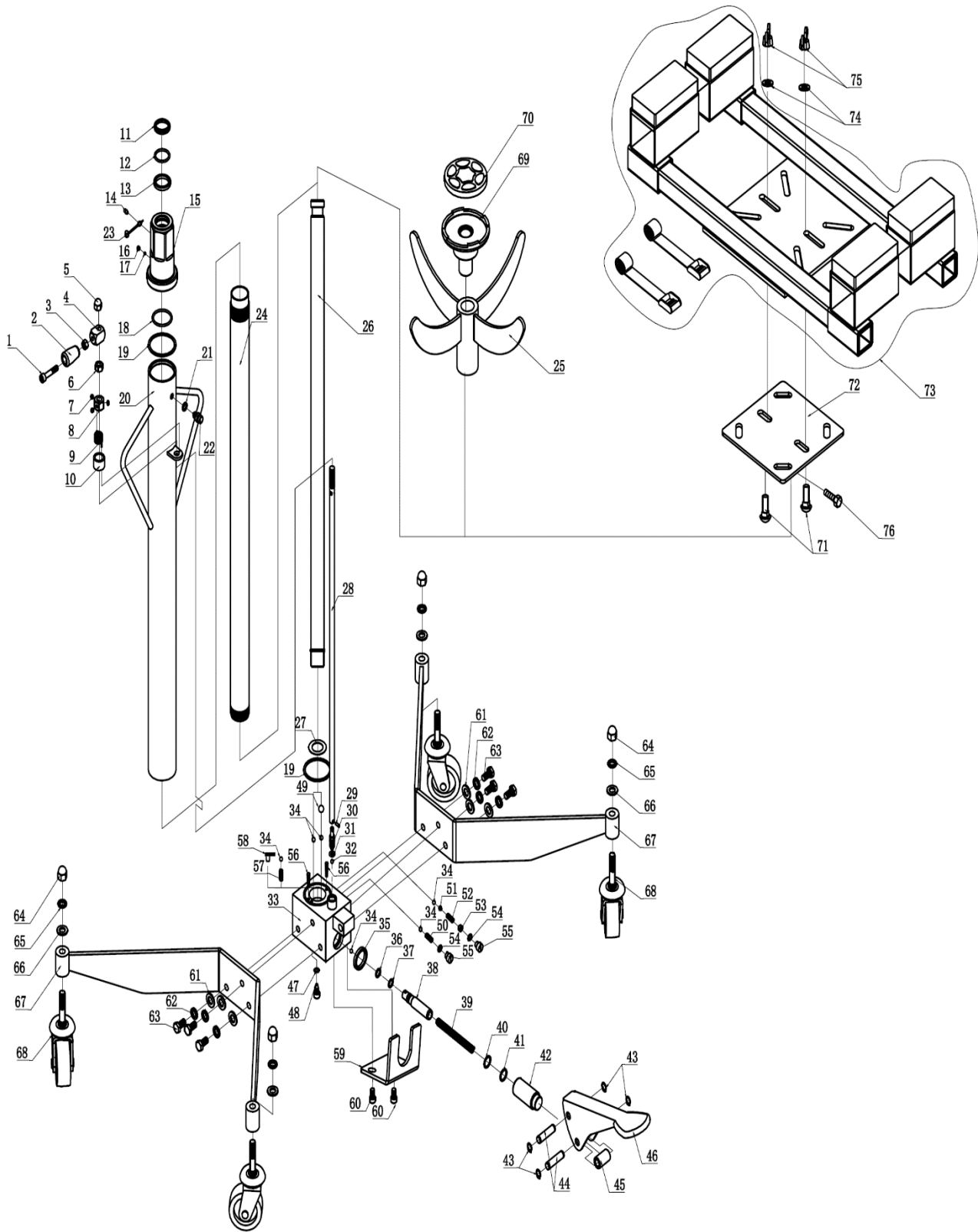

PARTS LIST

Part#	Description	Qty	Part#	Description	Qty
1	Screw	1	39	Spring	1
2	Handle	1	40	Washer	1
3	Nut	1	41	O-Ring	1
4	Handle Seat	1	42	Big Piston Core	1
5	Nut	1	43	Retainer Ring	4
6	Nut	1	44	Pin	2
7	Screw	1	45	Roller	1
8	Spring Seat	1	46	Foot Pedal	1
9	Spring	1	47	Copper Washer	1
10	Spring Cover	1	48	Screw	1
11	Dust Ring	1	49	Steel Ball	1
12	O-Ring	1	50	Spring	1
13	O-Ring	1	51	Steel Ball Seat	1
14	Oil Cup	1	52	Spring	1
15	Cylinder Cap	1	53	Screw	1
16	Screw	1	54	O-Ring	2
17	Steel Ball	1	55	Screw	2
18	O-Ring	1	56	Filter	2
19	Seal	2	57	Spring	1
20	Oil Tank	1	58	Steel Ball Plate	1
21	Seal	1	59	Limited Plate	1
22	Air Venting Screw	1	60	Screw	2
23	Lubricating Nipple Cap	1	61	Washer	6
24	Cylinder	1	62	Lock Washer	6
25	Saddle	1	63	Bolt	6
26	Piston	1	64	Nut	4
27	Seal	1	65	Lock Washer	4
28	Link Rod	1	66	Washer	4
29	Pin	1	67	Leg	2
30	Release Valve Rod	1	68	Caster	4
31	O-Ring	1	69	Round Saddle	1
32	Steel Ball	1	70	Rubber Pad	1
33	Pump Base	1	71	Bolt	2
34	Steel Ball	6	72	Connection Plate	1
35	O-Ring	1	73	Oil Tank Support	1
36	O-Ring	1	74	Washer	2
37	Washer	1	75	Nut	2
38	Small Piston	1	76	Bolt	1

WARRANTY

TradeQuip products have been carefully tested and inspected before shipment and are guaranteed to be free from defective materials and workmanship for a period of 12 months from the date of purchase except where tools are hired out when the guarantee period is ninety days from the date of purchase.

Should this piece of equipment develop any fault, please return the complete tool to your nearest authorised warranty repair agent or contact TQB Brands Pty Ltd Warranty team – warranty@tqbbrands.com.au.

If upon inspection it is found that the fault occurring is due to defective materials or workmanship, repairs will be carried out free of charge. This guarantee does not apply to normal wear and tear, nor does it cover any damage caused by misuse, careless or unsafe handling, alterations, accident, or repairs attempted or made by any personnel other than the authorised TQB Brands Pty Ltd repair agent.

This guarantee applies in lieu of any other guarantee expressed or implied and variations of its terms are not authorised.

Your TQB Brands Pty Ltd guarantee is not effective unless you can produce upon request a dated receipt or invoice to verify your proof of purchase within the 12 month period.

Consumer Guarantee

Our goods come with a guarantee that cannot be excluded under the Australian Consumer Law. You are entitled to a replacement or refund for a major failure and compensation for any other reasonably foreseeable loss or damage. You are also entitled to have the goods repaired or replaced if the goods fail to be of acceptable quality and the failure does not amount to a major failure.



All images and illustrations shown are for reference purposes only. All information, specifications and illustrations in this manual are based on the latest information available at the time of publication and are subject to change without notice. The information in this manual is periodically revised to ensure the latest information is included. Download the latest version of this manual and other related technical documentation from www.tqbbrands.com.au.