

## EM converterLED BASIC 200 V

Emergency lighting LED Driver

### Product description

- Emergency lighting LED Driver for manual testing
- For LED modules with a forward voltage of 50 – 200 V
- Low profile casing (21 x 30 mm cross-section)
- For luminaire installation
- 5-year guarantee

### Properties

- Non maintained operation
- 1 or 3 h rated duration
- Operating time selectable with plug (duration link)
- Compatible with all dimmable and non-dimmable constant current LED Drivers (see LED Driver compatibility, page 6)
- 3-pole technology: 2-pole LED module changeover and delayed power switching for the LED Driver
- Automatic shutdown of output if LED load is out of range
- Constant power output
- Maximum light output for all LED modules
- Electronic charge system
- Deep discharge protection
- Short-circuit-proof battery connection
- Polarity reversal protection for battery

### Batteries

- High-temperature cells
- NiCd or NiMH batteries
- D, Cs or LA cells
- 4-year design life
- 1-year guarantee



**Standards**, page 7

**Wiring diagrams and installation examples**, page 8



### EM converterLED BASIC 200 V Emergency lighting LED Driver

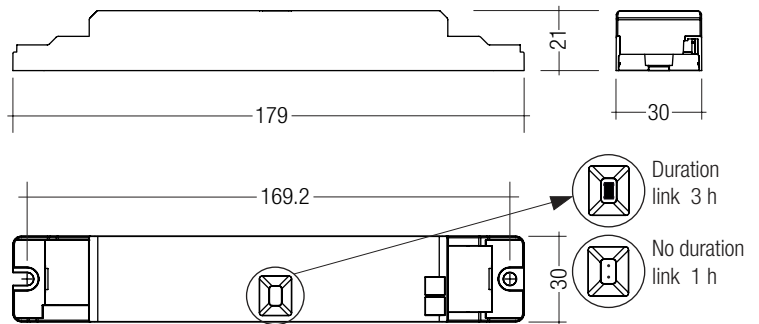

Note: LED Driver supplied with duration link in 3 hours position. Remove duration link for 1 hour duration. Duration link must be set before battery and mains connection.

#### Technical data

Rated supply voltage	220 – 240 V
Mains frequency	50 / 60 Hz
Typ. $\lambda$ (at 230 V, 50 Hz)	0.55
LED module forward voltage range	50 – 200 V
Output current	see page 4
Time to light	< 0.25 s from detection of emergency event
Overvoltage protection	320 V (for 1 h)
Maximum output voltage	250 V
Battery charging time	20 h <sup>①</sup>
Ambient temperature range $t_a$	-5 ... + 55 °C
Max. casing temperature $t_c$	70 °C
Mains voltage changeover threshold	according to EN 60598-2-22
Type of protection	IP20

<sup>①</sup> 16 h battery charging time for 2 h emergency lighting function according to AS 2293.

#### Ordering data

Type	Article number	Rated duration	Number of cells	Packaging, carton	Packaging, pallet	Weight per pc.
EM converterLED BASIC 104 200V	89800308	1/3 h	4	10 pc(s).	800 pc(s).	0.078 kg
EM converterLED BASIC 105 200V	89800309	1/3 h	5	10 pc(s).	800 pc(s).	0.078 kg

#### Specific technical data

Type	Rated duration	Max. output power	Mains current in charging operation	Rated power in charging operation
EM converterLED BASIC 104 200V	1 h	3.85 W	25 mA	3.0 W
	3 h	3.85 W	30 mA	4.0 W
EM converterLED BASIC 105 200V	1 h	4.85 W	25 mA	3.0 W
	3 h	4.85 W	30 mA	4.5 W

RoHS

ACCESSORIES

### Test switch EM3

#### Product description

- For connection to the emergency lighting unit
- For checking the device function
- Plug connection



#### Ordering data

Type	Article number	Packaging, bag	Packaging, carton	Weight per pc.
Test switch EM 3	89899956	25 pc(s).	200 pc(s).	0.013 kg

ACCESSORIES

### Status indication green LED

#### Product description

- A green LED indicates that charging current is flowing into the battery
- Plug connection



#### Ordering data

Type	Article number	Packaging, bag	Packaging, carton	Weight per pc.
LED EM green, 1.0 m CON	89800269	25 pc(s).	200 pc(s).	0.015 kg
LED EM green, HO 1.0 m CON	89800271	25 pc(s).	200 pc(s).	0.015 kg
LED EM green, 0.6 m CON	89800472	25 pc(s).	200 pc(s).	0.005 kg
LED EM green, HO 0.6 m CON	89800473	25 pc(s).	200 pc(s).	0.005 kg
LED EM green, 0.3 m CON	89800270	25 pc(s).	200 pc(s).	0.005 kg
LED EM green, HO 0.3 m CON	89800272	25 pc(s).	200 pc(s).	0.005 kg

**Battery selection**

EM converterLED BASIC, 1 / 3 h

		Type	EM converterLED BASIC 104 200V		EM converterLED BASIC 105 200V	
		Article no.	89800308		89800309	
		Cells	4 cells		5 cells	
		Duration	1 h	3 h	1 h	3 h
Technology and Design capacity	Number of cells	Type	Article no.	Assignable batteries		
NiCd 1.6Ah Cs cells	stick	1 x 4 Accu-NiCd C 4A	89899692	•		
	stick	1 x 5 Accu-NiCd C 5A	89899695		•	
	stick + stick	2 + 2 Accu-NiCd C 4C	89899694	•		
	stick + stick	3 + 2 Accu-NiCd C 5C	89899697		•	
	side by side	4 x 1 Accu-NiCd C 4B	89899693	•		
	side by side	5 x 1 Accu-NiCd C 5B	89899696			•
NiCd 4Ah D cells <sup>®</sup>	stick	1 x 4 Accu-NiCd 4A 55	89800089		•	
	stick	1 x 5 Accu-NiCd 5A	89895973			•
	stick + stick	2 + 2 Accu-NiCd 4C	89895978		•	
	stick + stick	3 + 2 Accu-NiCd 5C 55	89800090			•
	side by side	4 x 1 Accu-NiCd 4B 55	89800385		•	
NiMH 2Ah Cs cells	stick	1 x 4 Accu-NiMH C 4A	89899700	•		
	stick	1 x 5 Accu-NiMH C 5A	89899703		•	
	side by side	5 x 1 Accu-NiMH C 5B	89899704		•	
NiMH 4Ah LA cells	stick	1 x 4 Accu-NiMH 4Ah 4A CON	89800442		•	
	stick + stick	2 + 2 Accu-NiMH 4Ah 4C CON	89800438		•	
	stick + stick	3 + 2 Accu-NiMH 4Ah 5C CON	89800439			•

<sup>®</sup> 50 °C batteries also available (see separate datasheet at [www.tridonic.com](http://www.tridonic.com))

**Battery charge / discharge data**

EM converterLED BASIC, 1 / 3 h

Type	EM converterLED BASIC 104 200V		EM converterLED BASIC 105 200V	
	Article no.	89800308	89800309	
Cells	4 cells		5 cells	
Duration	1 h	3 h	1 h	3 h
Charging current	105 mA	210 mA	105 mA	210 mA
Discharge current	750 – 960 mA	750 – 960 mA	750 – 960 mA	750 – 960 mA

**Typ. LED current/voltage characteristics**

The LED current in emergency mode is automatically adjusted by the EM converterLED module based on the total forward voltage of the LED modules connected and the associated battery.

EM converterLED BASIC 104 200V

Article number: 89800308

4.8 V battery voltage

750 – 960 mA battery discharge current (tolerance)

EM converterLED BASIC 105 200V

Article number: 89800309

6.0 V battery voltage

750 – 960 mA battery discharge current (tolerance)

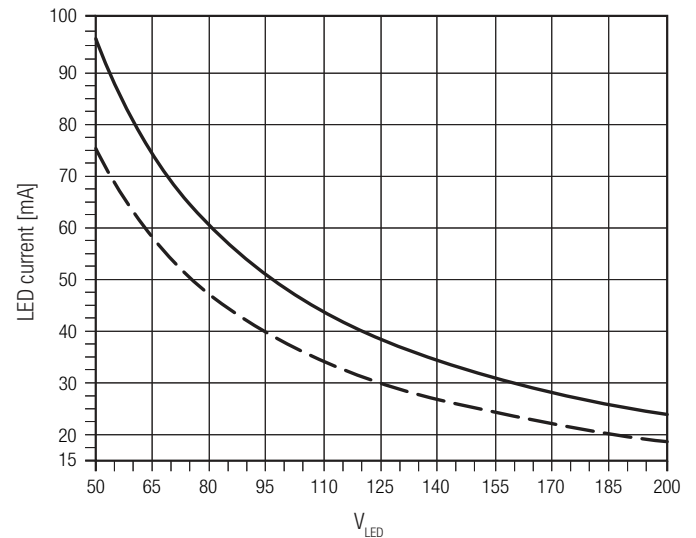
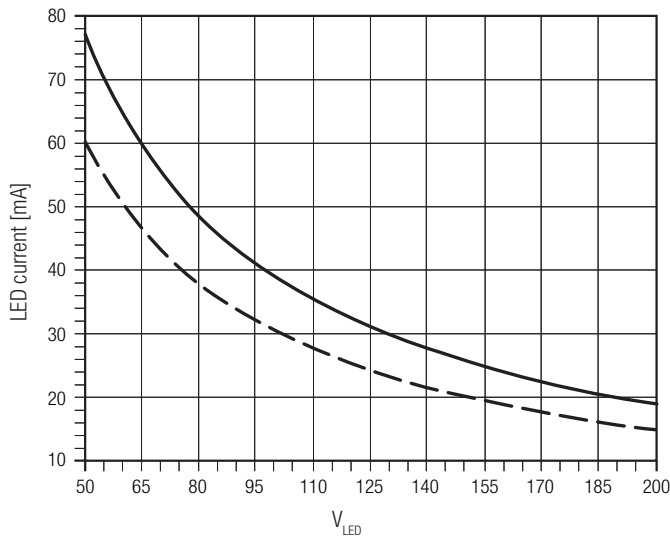

— — — — LED current at nominal battery voltage and min. battery discharge current  
 — — — — LED current at nominal battery voltage and max. battery discharge current

**LED peak current at start in emergency mode – 4 cells**

Voltage	Inrush current	Duration
52.1 V	146 mA	16.7 ms
62.0 V	134 mA	14.1 ms
74.7 V	121 mA	11.5 ms
84.8 V	111 mA	9.4 ms
100.0 V	100 mA	7.7 ms
110.1 V	94 mA	6.9 ms
122.6 V	86 mA	6.3 ms
135.1 V	81 mA	4.3 ms
145.0 V	77 mA	4.2 ms
155.8 V	73 mA	3.7 ms
168.3 V	68 mA	3.0 ms
180.8 V	57 mA	2.9 ms
190.8 V	51 mA	2.1 ms
200.6 V	36 mA	2.0 ms

**LED peak current at start in emergency mode – 5 cells**

Voltage	Inrush current	Duration
52.3 V	136 mA	25.7 ms
62.5 V	127 mA	18.9 ms
75.3 V	118 mA	14.9 ms
85.4 V	111 mA	12.4 ms
100.7 V	102 mA	9.6 ms
110.8 V	97 mA	8.4 ms
123.3 V	92 mA	7.6 ms
135.9 V	86 mA	6.6 ms
145.9 V	81 mA	5.8 ms
155.9 V	80 mA	5.3 ms
171.0 V	73 mA	4.4 ms
181.0 V	69 mA	3.9 ms
191.1 V	67 mA	3.2 ms
201.1 V	65 mA	3.0 ms

Note: LED peak current measured at the max. battery discharge current and at a max. battery voltage of 6 V (4 cells) or 7.5 V (5 cells).

**Isolation and electric strength testing of luminaires**

Electronic LED Drivers can be damaged by high voltage. This has to be considered during the routine testing of the luminaires in production.

According to IEC 60598-1 Annex Q (informative only!) or ENEC 303-Annex A, each luminaire should be submitted to an isolation test with 500 V<sub>DC</sub> for 1 second. This test voltage should be connected between the interconnected phase and neutral terminals and the earth terminal. The isolation resistance must be at least 2 MΩ.

As an alternative, IEC 60598-1 Annex Q describes a test of the electrical strength with 1,500 V<sub>AC</sub> (or 1,414 x 1,500 V<sub>DC</sub>). To avoid damage to the electronic devices this test **must not be conducted**.

**Technical data batteries****Accu-NiCd**

Case temperature range

to ensure 4 years design life

4.2 / 4.5 Ah D

1.6 Cs

Battery voltage/cell

Single cell dimensions

4.2/ 4.5 Ah D

Diameter

Height

1.6 Ah Cs

Diameter

Height

Capacity D

Capacity Cs

Max. short term temperature (reduced life-time)

Max. number discharge cycles

+5 °C to +55 °C

+5 °C to +50 °C

1.2 V

32.5 mm

60.5 mm

22.5 mm

42.5 mm

4.2 / 4.5 Ah

1.6 Ah

70 °C

4 cycles per year plus

4 cycles during

commissioning

5 pcs. per carton

Packing quantity

**Accu-NiMh**

Case temperature range

to ensure 4 years design life

2.0 Ah Cs

4.0 Ah LA

Battery voltage

Single cell dimensions

2.0 Ah Cs

Diameter

Height

4.0 Ah LA

Diameter

Height

Capacity Cs / LA

Max. short term temperature (reduced life-time)

Max. number discharge cycles 2.0 Ah Cs

+5 °C to +55 °C

+5 °C to +40 °C

1.2 V

22 mm

42.5 mm

18.3 mm

90 mm

2.0 Ah / 4.0 Ah

70 °C

4 cycles per year plus

4 cycles during

commissioning

2 cycles per year plus

4 cycles during

commissioning

5 pcs. per carton

Max. number discharge cycles 4.0 Ah LA

Packing quantity

**Storage, installation and commissioning**

Relevant information about storage conditions, installation and commissioning are provided in the battery datasheets.

**LED Driver compatibility**

The EM converterLED emergency unit use 3 pole technology and is compatible with most LED Drivers on the market, however it is important to check that the rating of the LED Driver does not exceed the values specified below:

- The max. allowed output current rating of the associated LED Driver is 2.4 A peak (current rating of switching relays of EM converterLED)
- The max. allowed inrush current rating of the associated LED Driver is 60 A peak for 1 ms (inrush current rating of switching relay of EM converterLED)
- The max. allowed output voltage of the associated LED Driver applied to the EM converterLED output is 450V (voltage withstand between adjacent contact of the single switching relay of the EM converterLED)
- The max. allowed LED load of the associated LED Driver is 150 W in operation. The load must be an LED module.

**Life-time**

Average life-time 50,000 hours under rated conditions with a failure rate of less than 10 %. Average failure rate of 0.2 % per 1000 operating hours.

**Maximum lead length**

LED 3 m<sup>Ⓢ</sup>

Status indication LED 1 m

Batteries 1.3 m

<sup>Ⓢ</sup> Note: The length of LED leads to the LED module must not be exceeded. Note that the length of the EM converterLED leads is added to the length of the leads from the LED Driver to the EM converterLED module when considering max. permitted lead length of the LED Driver. Leads should always be kept as short as possible.

**Mechanical details**

Casing manufactured from polycarbonate.

Glow-wire test according to EN 61347-1 with increased temperature of 960 °C passed.

LED status indicator

- Green
- Mounting hole 6.5 mm dia
- Lead length 0.3 m / 1.0 m
- Insulation rating: 90 °C
- Plug connection

Test switch

- Mounting hole 7.0 mm dia
- Lead length 0.55 m
- Plug connection

Battery leads

- Quantity: 1 red and 1 black
- Length: 1.3 m
- Wire type: 0.5 mm<sup>2</sup> solid conductor
- Insulation rating: 90 °C

Battery end termination

Push on 4.8 mm receptacle to suit battery spade fitted with insulating cover

Module end termination

8.0 mm stripped insulation

Two-piece batteries are supplied with a 200 mm lead with 4.8 mm receptacle at each end and insulating covers to connect the separate sticks together.

## Electrical connections

### Wiring

LED module/LED Driver/supply

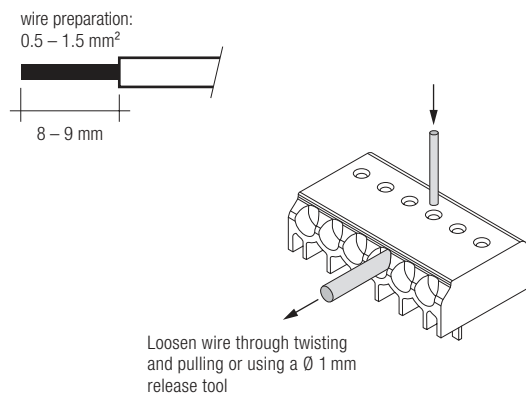

### Wiring type and cross section

Solid wire with a cross section of 0.5 – 1.5 mm<sup>2</sup>. Strip 8 – 9 mm of insulation from the cables to ensure perfect operation of terminals.

### Batteries

Connection method: 4.8 x 0.5 mm spade tag welded to end of cell.

For stick packs this connection is accessible after the battery caps have been fitted.

To inhibit inverter operation disconnect the batteries by removing the connector from the battery spade tag.

For battery data see separate data sheet.

### Phase to phase isolation

The use of different phases for switched line and unswitched line is permitted.

### Standards

- according to EN 50172
- according to EN 60598-2-22
- EN 61347-1
- EN 61347-2-13
- EN 61347-2-7
- EN 55015
- EN 61000-3-2
- EN 61000-3-3
- EN 61547
- EN 60068-2-64
- EN 60068-2-29
- EN 60068-2-30
- EN 62384

## Duration link selection

Duration	Usage duration link
3 h	 With link
1 h	 Without link

Emergency lighting LED Driver supplied with duration link in 3 hours position.

The position of the link will only be read on first power up. If it is changed afterwards both the battery and mains supply must be disconnected for 10 seconds to enable the EM converterLED to read the new link position on reconnection of the battery and mains. It will lead to a false battery failure indication if the link is changed after installation without this reset.

### Wiring guidelines

- The LED terminals, battery, indicator LED and test switch terminals are classified as SELV (output voltage < 120 V DC). Keep the wiring of the input terminals separated from the wiring of the SELV equivalent terminals or consider special wiring (double insulation, 6 mm creepage and clearance) when these connections should be kept SELV.
- The output to the LED is DC but has high frequency content, which should be considered for good EMC compliance.
- LED leads should be separated from the mains connections and wiring for good EMC performance.
- Maximum lead length on the LED terminals is 3 m. For a good EMC performance keep the LED wiring as short as possible.
- Maximum lead length for the Test switch and Indicator LED connection is 1 m. The test switch and Indicator LED wiring should be separated from the LED leads to prevent noise coupling.
- Battery leads are specified with 0.5 mm cross section and a length of 1.3 m

To ensure that a luminaire containing LED emergency units complies with EN 55015 for radio frequency conducted interference in both normal and emergency mode it is essential to follow good practice in the wiring layout.

Within the luminaire the switched and unswitched 50 Hz supply wiring must be routed as short as possible and be kept as far away as possible from the LED leads. Through wiring may affect the emc performance of the luminaire.

The length of LED leads must not be exceeded. Note that the length of the EM converterLED leads is added to the length of the leads from the LED Driver to the EM converterLED module when considering max. permitted lead length of the LED Driver.

### Maximum loading of automatic circuit breakers

Automatic circuit breaker type	B10	B13	B16	B20	C10	C13	C16	C20	Inrush current	
Installation Ø	1.5 mm <sup>2</sup>	1.5 mm <sup>2</sup>	1.5 mm <sup>2</sup>	2.5 mm <sup>2</sup>	1.5 mm <sup>2</sup>	1.5 mm <sup>2</sup>	1.5 mm <sup>2</sup>	2.5 mm <sup>2</sup>	I <sub>max</sub>	time
<b>EM converterLED 104 BASIC 200V</b>	90	130	130	130	180	260	260	260	10 A	120 µs
<b>EM converterLED 105 BASIC 200V</b>	90	130	130	130	180	260	260	260	10 A	120 µs

### Wiring diagrams

One or more LED modules with a total forward voltage of 50 to 200 V can be connected to the EM converterLED 200V module. These LED module(s), marked with "Emergency" are operated in emergency mode from the associated battery. In normal mains mode all LED modules are operated by the mains LED Driver.

Use of the test switch:

For checking the device function press the test switch for a minimum of 3 seconds.

### EM converterLED BASIC with one LED module for non-maintained emergency operation

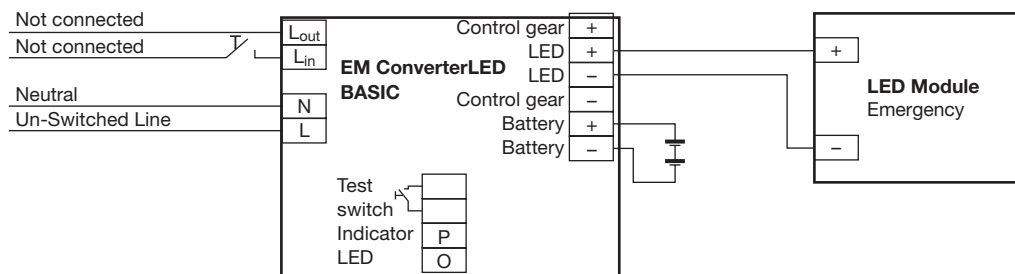

### EM converterLED BASIC with a standard LED Driver and one LED module for mains and emergency operation

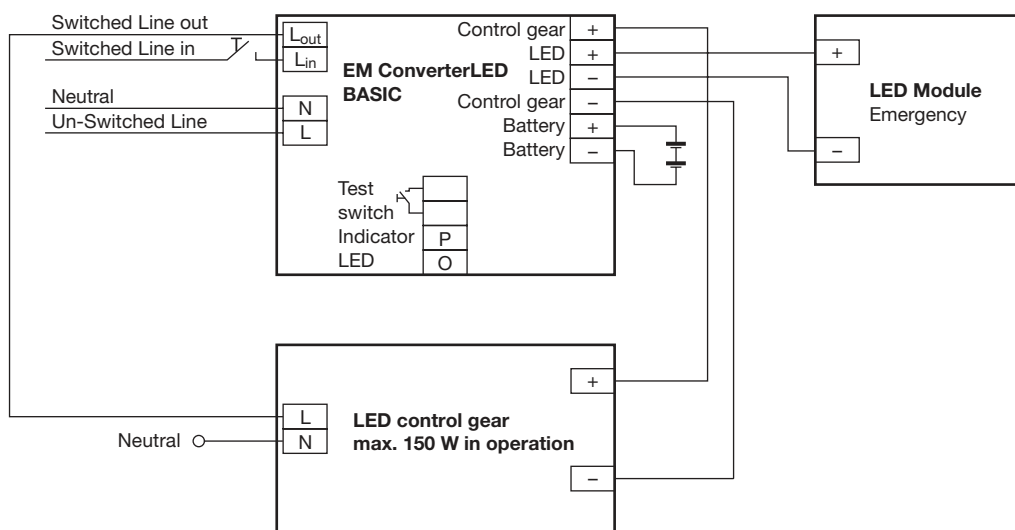

EM converterLED BASIC with a standard LED Driver and series operation of LED modules

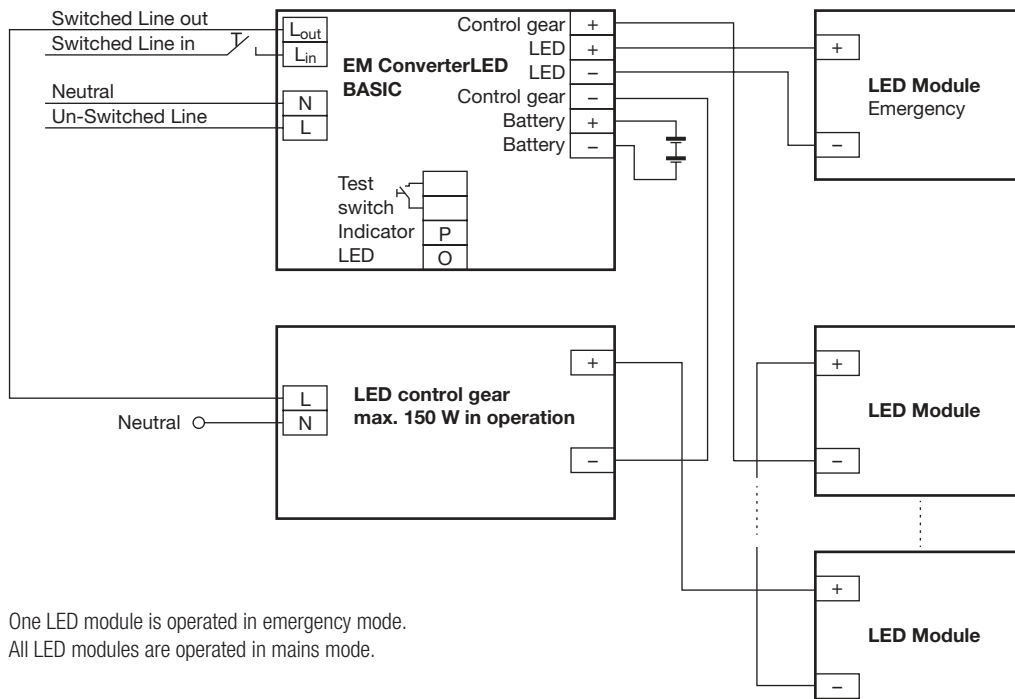

EM converterLED BASIC with a standard LED Driver and series operation of LED modules

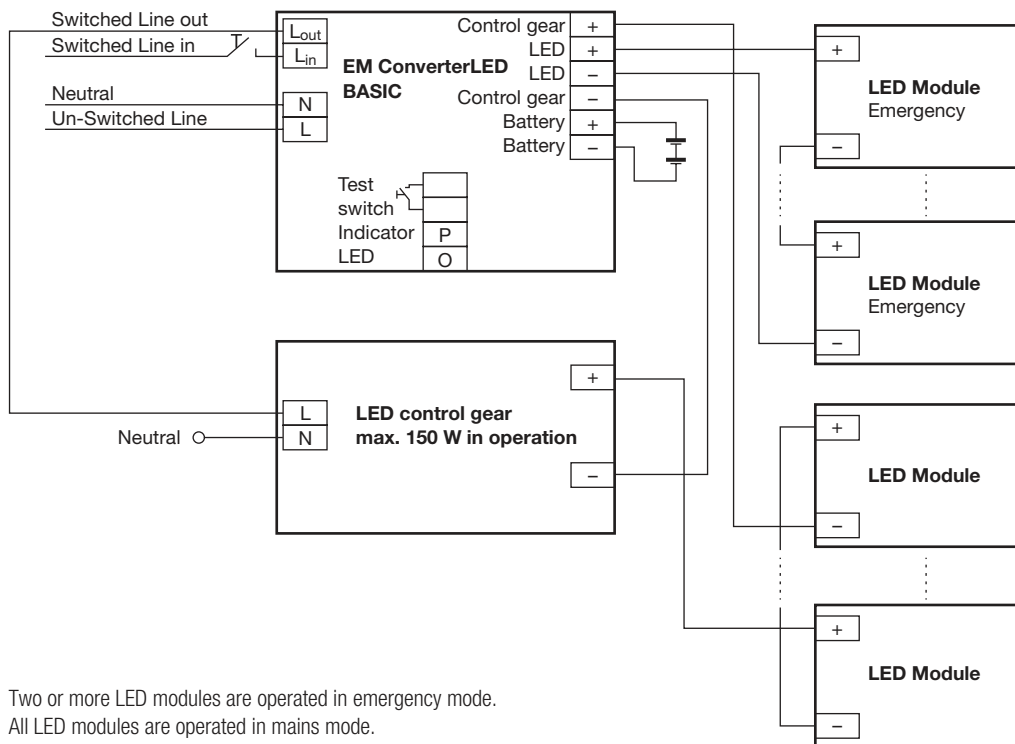

EM converterLED BASIC with a standard LED Driver and parallel operation of LED modules

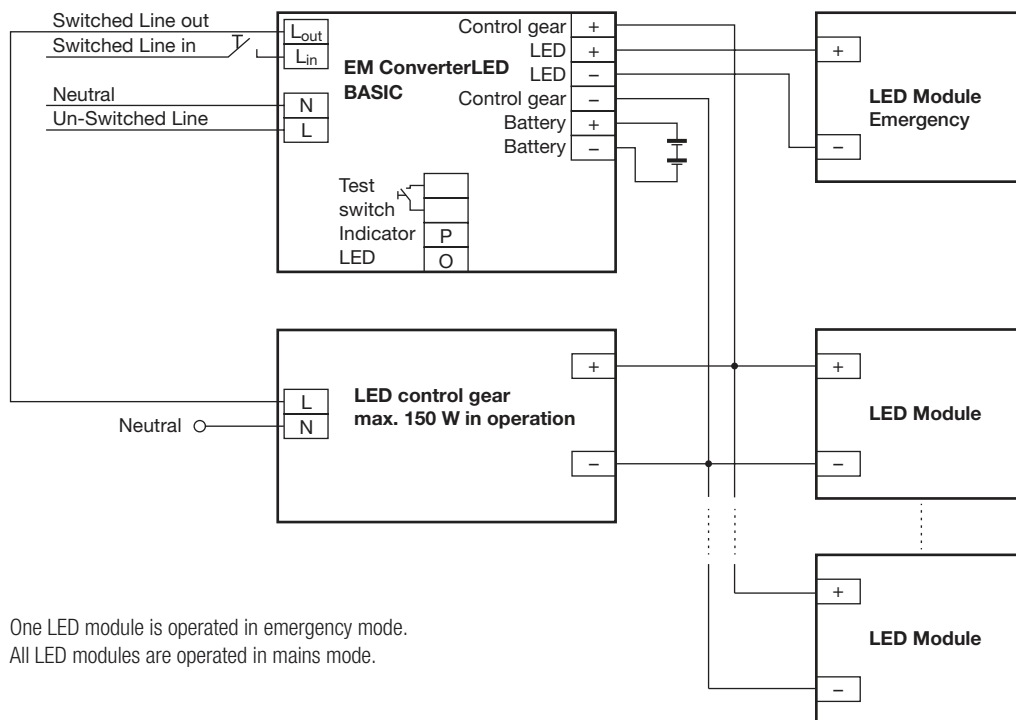

One LED module is operated in emergency mode.  
All LED modules are operated in mains mode.

EM converterLED BASIC with a standard LED Driver and parallel operation of LED modules

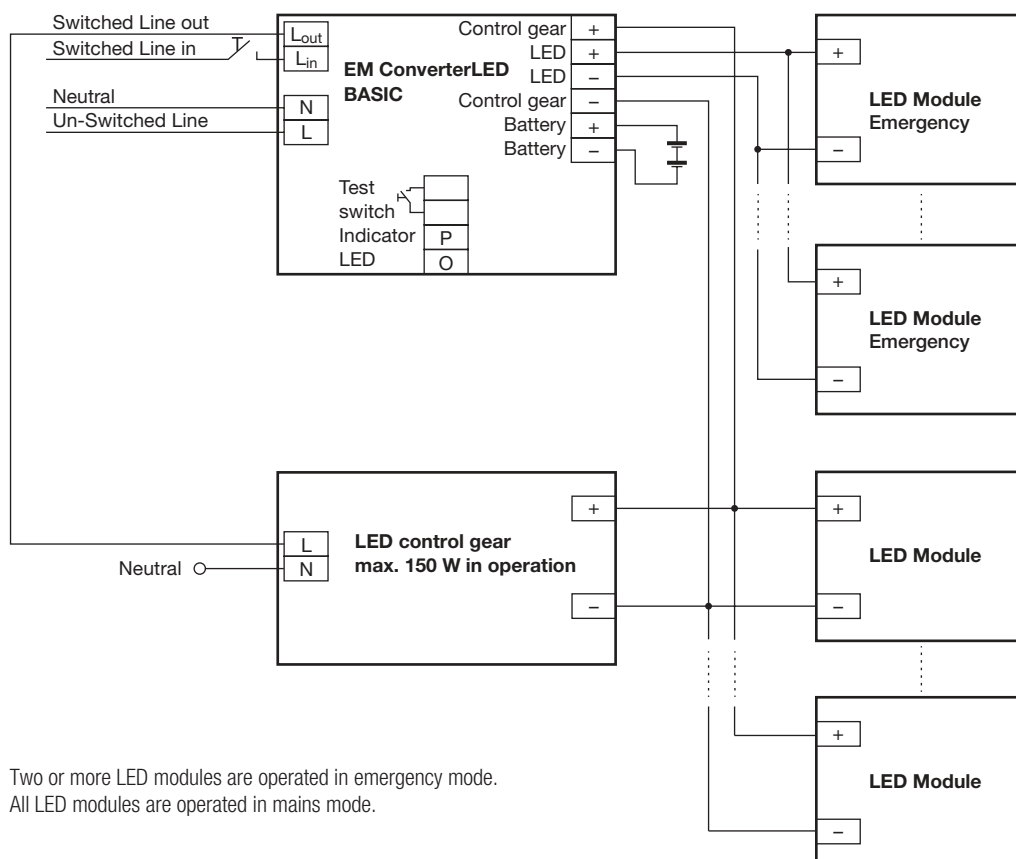

Two or more LED modules are operated in emergency mode.  
All LED modules are operated in mains mode.

#### Additional information

Additional technical information at [www.tridonic.com](http://www.tridonic.com) → Technical Data

Guarantee conditions at [www.tridonic.com](http://www.tridonic.com) → Services

Life-time declarations are informative and represent no warranty claim.  
No warranty if device was opened.