

TURCK

Your Global Automation Partner

IM(X)12-AI01-1I-1IU1R Isolating Transducer

Contents

1	About this document	5
2	Scope	5
3	Safety Integrity Level	6
4	Product description	6
4.1	Safety function	7
4.1.1	Safety accuracy	7
4.2	Safe state	8
4.3	PFH: Probability of dangerous failure per hour (High Demand mode)	8
4.4	PFD: Average probability of dangerous failure on demand (Low Demand mode)	9
5	Safety-planning	10
5.1	Architectural specificatons	10
5.2	Assumptions	10
5.2.1	FMEDA results	11
5.3	Examples of using these results	12
5.3.1	Probability of dangerous failure per hour (High Demand Mode)	12
5.3.2	Average probability of dangerous failure on demand (Low Demand Mode)	12
6	Operating instructions	13
6.1	General	13
6.2	Before operation	14
6.2.1	Parameterization	16
6.3	Operation	17
6.4	After operation	18
7	Connection and wiring diagrams	19
8	Terms and abbreviations	20
9	Proof tests	20
10	Certificate	21
11	Document history	21



1 About this document

This safety manual contains all information that is required to operate the device in functional safety systems. Read this manual carefully before using the device.

This document addresses only functional safety according to IEC 61508. Other aspects, such as intrinsic safety, are not considered.

All instructions must be followed in order to assure functional safety.

Always make sure that this is the latest version of the safety manual at www.turck.com. The English version is considered the definitive document. Care was taken in the production of the translations of this document. If there is any uncertainty in its interpretation, always refer to the English version of the safety manual or contact TURCK directly.

2 Scope

This safety manual is valid for the following devices.

ID	Product name	Number of channels	Clamps	Power-Bridge	Intrinsic Safety
7580308	IMX12-AI01-1I-1IU1R-HPR/24VDC	1	Screw clamps	Yes	Yes
7580309	IMX12-AI01-1I-1IU1R-H0/24VDC	1	Screw clamps	No	Yes
7580310	IMX12-AI01-1I-1IU1R-HPR/24VDC/CC	1	Spring type terminals	Yes	Yes
7580311	IMX12-AI01-1I-1IU1R-H0/24VDC/CC	1	Spring type terminals	No	Yes
7580328	IM12-AI01-1I-1IU1R-HPR/24VDC	1	Screw clamps	Yes	No
7580329	IM12-AI01-1I-1IU1R-H0/24VDC	1	Screw clamps	No	No
7580330	IM12-AI01-1I-1IU1R-HPR/24VDC/CC	1	Spring type terminals	Yes	No
7580331	IM12-AI01-1I-1IU1R-H0/24VDC/CC	1	Spring type terminals	No	No

3 Safety Integrity Level

The devices are rated to a SIL of:

SIL 2, SC3

4 Product description

Intrinsically safe passive 2-wire transmitters in the hazardous area are supplied with power via the IMX12-AI01-1I-1IU1R transmitter power supply isolators and their live zero output signals are transmitted, electrically isolated, to the non-hazardous area. Alternatively, it is also possible to transmit the standardized current signals from active transducers from the hazardous area to the non-hazardous area.

The transmitter can actively output the transmitted current signal at the current output [A1A] (source) or record it as a current sink when an external voltage source is connected. Switching between the two operating modes is done automatically depending on the external wiring. In addition to the analog measuring signal, the digital signals of the HART communication can also be transmitted bidirectionally.

The input current signal can be output proportionally as a normalized voltage in the range [1...5 V] via a further output terminal.

With the third output [A1D], a relay as a limit value switch, overshoots or undershoots of the input current signal can be provided as a binary switching signal depending on a set value. The relay, which is equipped with a normally open contact, can also be operated in inverted mode.

The measuring transducer supply isolators are equipped with input circuit monitoring. In the event of a fault in the input circuit (line break, short circuit), signaling is provided via a LED on the front of the device and, in the variants with power bridge, also via a collective fault signal output.

The IMX12-AI measuring transducer supply isolators are available as devices with non-intrinsically safe input circuits (IM12-AI), while retaining the functional requirements and also the safety requirements.

4.1 Safety function

Variants	Assignment	Safety Function
IM(X)12-AI01-1I-1IU1R	E1 → A1A	The current present in the input circuit [E1] should be transferred to the output circuit [A1A] proportionally at an accuracy of 0.4 mA within 50 ms. For use in safety-related configurations, the input circuit must be connected with a passive or active transmitter. The input circuit shall detect input currents between 3.8 mA and 20.5 mA as a valid measured value according to NE43.
IM(X)12-AI01-1I-1IU1R	E1 → A2A	The current present in the input circuit [E1] should be transferred to the output circuit [A2A] (voltage output) within 50 ms. The voltage at the output circuit [A2A] should not deviate by more than 100 mV from the product (current in input circuit [E1]) \times (250 Ω).
IM(X)12-AI01-1I-1IU1R	E1 → A1D	The current present in the input circuit [E1] should be transferred to the output circuit [A1D] (relay as limit switch). If the current in the input circuit [E1] exceeds or falls below the parameterized limit value depending on the monitoring mode, the relay output [A1D] should switch to the safe state within 100ms. The deviation between the current value at which the relay switches to the safe state and the parameterized value should not exceed 0.4 mA. A fuse must limit the current through relays to 2 A to prevent contact welding.

The products can be used with a hardware fault tolerance HFT = 0, e.g. in a 1oo1 architecture up to SIL 2 and with a hardware fault tolerance HFT = 1, e.g. in a 1oo2 architecture up to SIL 3, dependent of the application The LED State is not part of the safety function.

The common alarm output is not part of the safety function.

The user must detect and maintain the safe state of the system:

- currents < 3.6 mA and > 21 mA
- voltages < 0.9 V and > 5.25 V

The clamps of the analog output "voltage" shall not be connected, if the analog output "current" is used for safety applications.

The clamps of the analog output "current" shall not be connected, if the analog output "voltage" is used for safety applications

4.1.1 Safety accuracy

The safety accuracy is < 2 % FS.

4.2 Safe state

The safe state is always the “low” state.

The “low” state depends on the output type:

Output type	Requirement state “low”
Relay A1D	Relay is de-energized
Analog output A1A	< 3.6 mA
Analog output A2A	< 0.9 V

If the unit changes to the safe state due to an internal error, it must be replaced within 24 h.

4.3 PFH: Probability of dangerous failure per hour (High Demand mode)

A **SIL2** is specified.

In the following table 3 from 7.6.2.9 EN 61508-1:2010 is a PFH of less than 10^{-6} h^{-1} required.

A failure limit of 1 FIT corresponds to a PFH of 10^{-9} h^{-1} .

Table 3 from 7.6.2.9 EN 61508-1

Safety Integrity Level (SIL)	Probability of dangerous Failure per Hour from the safety function [h^{-1}] (PFH)
4	$\geq 10^{-9} \dots < 10^{-8}$
3	$\geq 10^{-8} \dots < 10^{-7}$
2	$\geq 10^{-7} \dots < 10^{-6}$
1	$\geq 10^{-6} \dots < 10^{-5}$

4.4 PFD: Average probability of dangerous failure on demand (Low Demand mode)

A **SIL2** is specified.

In the following table 2 from 7.6.2.9 EN 61508-1:2010 is a PFD_{avg} of less than $10^{-2} h^{-1}$ required.

Table 2 from 7.6.2.9 EN 61508-1

Safety Integrity Level (SIL)	Average probability of a dangerous failure when the safety function is requested (PFD_{avg})
4	$\geq 10^{-5} \dots < 10^{-4}$
3	$\geq 10^{-4} \dots < 10^{-3}$
2	$\geq 10^{-3} \dots < 10^{-2}$
1	$\geq 10^{-2} \dots < 10^{-1}$

In the safety chain, the device is granted a share of 10 % of the respective failure limit value.

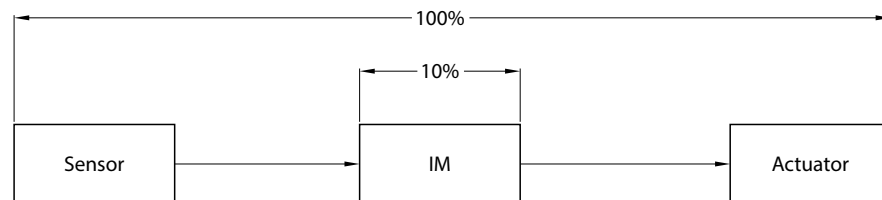

This means that the failure limit value must be less than 10^{-3} .

The basis of the consideration is a test interval of 8760 h and an MTTR or MRT of 24 h.

5 Safety-planning

This chapter provides information for planning a safety-related loop.

The device is not specified for a certain application. Make sure that the data provided in this chapter is valid for your target application.

Special application-specific factors may cause the premature wear of the device and must be taken into consideration when planning systems; take special measures to compensate for a lack of experience based values, e.g. through implementation of shorter test intervals.

The suitability for specific applications must be assessed by considering the particular overall safety-related system with regard to the requirements of IEC 61508.

Safety-planning must only be carried out by trained and qualified personnel.

If there is any doubt contact TURCK directly.

5.1 Architectural specifications

Due to architectural considerations the following characteristics are specified:

Type	A
HFT	0

Useful lifetime:

Experience has shown that the useful lifetime often lies within a range of 8...12 years. It can be significantly less if elements are operated near their specification limits. However, it can be extended by appropriate measures. For example, heavy temperature fluctuations could potentially decrease the useful lifetime, as constant temperature below 40 °C could potentially increase the useful lifetime.

For the relay outputs ($\cos \phi = 1, I = 2 \text{ A AC}$) the useful lifetime is 8...12 years or 50000 switching cycles.

The relay outputs shall be protected by a fuse that limits the current to 2 A to avoid contact welding.

Two devices must not be used for the same safety-function to increase the hardware fault tolerance to achieve a higher SIL. A 1oo2 architecture does not achieve a SIL3.

5.2 Assumptions

- Failure rates are constant for 10 years, wear out mechanisms are not included.
- Propagation of failures are not relevant.
- External power supply failure rates are not included.
- All components that are not part of the safety function and cannot influence the safety function (feedback immune) are excluded.

5.2.1 FMEDA results

According to table 2 and table 3 from 7.4.4.2.2 EN 61508-1:2010, depending on the operating mode (Typ A or Typ B) and taking into account the hardware fault tolerance of HFT=0, the following SFF values are applied:

- For type A devices, the SFF must be greater than 60 %.
- For type B devices, the SFF must be greater than 90 %.

Table 2 from 7.4.4.2.2 EN 61508-2 (Typ A)

Part of safe failures of an element	HFT=0	HFT=1	HFT=2
< 60 %	SIL 1	SIL 2	SIL 3
60 % ... < 90 %	SIL 2	SIL 3	SIL 4
90 % ... < 99 %	SIL 3	SIL 4	SIL 4
≥ 99 %	SIL 3	SIL 4	SIL 4

Table 3 from 7.4.4.2.2 EN 61508-2 (Typ B)

Part of safe failures of an element	HFT=0	HFT=1	HFT=2
< 60 %	not allowed	SIL 1	SIL 2
60 % ... < 90 %	SIL 1	SIL 2	SIL 3
90 % ... < 99 %	SIL 2	SIL 3	SIL 4
≥ 99 %	SIL 3	SIL 4	SIL 4

The following safety characteristic are the results of the FMEDA.

IMX12-AI01-1I-1IU1R / IM12-AI01-1I-1IU1R	λ_{SD}	λ_{SU}	λ_{DD}	λ_{DU}	No effect	SFF	DC
E1 → A1A	0	3.02	462.79	125.54	891.33	78.77	78.66
E1 → A2A	0	3.02	485.21	123.69	868.76	79.79	79.69
E1 → A1D with current output	0	25.48	459.98	224.22	773.00	68.41	67.23
E1 → A1D with voltage output	0	25.48	482.40	222.36	750.43	69.55	68.45

The stated Safe Failure Fraction (SFF) is for reference only. The complete subsystem will need to be evaluated to determine the overall SFF.

The failure rates used in this analysis are the basic failure rates from the Siemens standard SN 29500 based on the average ambient temperature of components of 40 °C.

„No effect“ is a failure mode of a component that plays part in implementing the safety function but is neither a safe nor a dangerous failure.

5.3 Examples of using these results

5.3.1 Probability of dangerous failure per hour (High Demand Mode)

The PFH values are based on a worst-case diagnostic test rate and a reaction time as stated in the table below. The ratio of the diagnostic test rate to the demand rate shall equal or exceed 100.

IMX12-AI01-1I-1IU1R / IM12-AI01-1I-1IU1R	PFH	Reaction time
E1 → A1A	1.26 E-7 1/h	50 ms
E1 → A2A	1.24 E-7 1/h	50 ms
E1 → A1D with current ouput	2.25 E-7 1/h	100 ms
E1 → A1D with voltage ouput	2.23 E-7 1/h	100 ms

5.3.2 Average probability of dangerous failure on demand (Low Demand Mode)

With the FMEDA results and the values specified in the following table the average frequency of dangerous failure can be calculated exemplarily:

T1	8760 h
MTTR	24 h
MTR	24 h
IMX12-AI01-1I-1IU1R / IM12-AI01-1I-1IU1R	PFDavg
E1 → A1A	5.64 E-4
E1 → A2A	5.57 E-4
E1 → A1D with current output	9.99 E-4
E1 → A1D with voltage output	9.91 E-4

6 Operating instructions

6.1 General

- ▶ The device must be registered online: <http://www.turck.com/SIL>
- ▶ The device must only be carried out, fitted, installed, operated, commissioned and maintained by trained and qualified personnel.
- ▶ The device is not specified for a certain application. Make sure that application-specific aspects are considered.
- ▶ Data from other documents, e.g. data sheets, is not valid for functional safety operation. Devices must be used in cabinets in an typical industrial field environment only. The following restrictions describe the operation and storage conditions:
- ▶ Ensure that the environment complies with the following ratings

Minimum ambient temperature	-25 °C
Maximum ambient temperature	70 °C
Minimum storage temperature	-40 °C
Maximum storage temperature	80 °C
Maximum air humidity	95 %
Minimum air pressure	80 kPa
Maximum air pressure	110 kPa

- ▶ The average temperature over a long period of time directly on the exterior sidewall of the housing must be maximum 40 °C.
- ▶ The temperature on the exterior sidewall of the housing can deviate considerably from the temperature in the control cabinet.
- ▶ The temperature on the exterior sidewall of the housing must be observed in a steady state.
- ▶ In case the temperature on the exterior sidewall of the housing is higher, the failure rates from „5.2.1 FMEDA results“ on page 11 must be adjusted:
- ▶ For a higher average temperature of 60 °C on the exterior sidewall of the housing, the failure rates are multiplied by an experience factor of 2.5.
- ▶ Ensure that sufficient heat dissipation is provided.
- ▶ Protect the device from radiated heat and severe temperature fluctuations.
- ▶ Protect the device from dust, dirt, moisture, shock, vibration, chemical stress, increased radiation and other environmental influences.
- ▶ Ensure a degree of protection of at least IP20 according to IEC 60529 at the mounting location.
- ▶ Ensure that the electromagnetic stress does not exceed the requirements of IEC 61326-3.1.
- ▶ If there is a visible error, e.g. defective housing the device must not be used.
- ▶ During operation of the device, surface temperatures may occur that could lead to burns if touched.
- ▶ The device must not be repaired. If problems occur with regard to functional safety, TURCK must be notified immediately and the device must be returned immediately to:

TURCK GmbH
Witzlebenstraße 7
45472 Mülheim
Germany

6.2 Before operation

- ▶ Fasten the device to a din rail according EN 60715 (TH35) as follows:

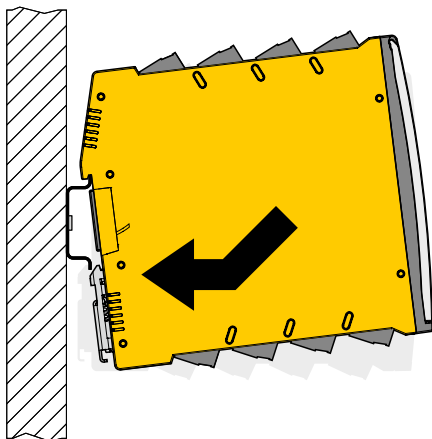

Fig. 1: Fasten the device

- ▶ Connect cables according to the wiring diagrams in „7 Connection and wiring diagrams“ on page 19
- ▶ Use cables with the following terminal cross section
 - rigid: 0.2 mm² to 2.5 mm² or
 - flexible: 0.2 mm² to 2.5 mm²
- ▶ When wiring with stranded wires: Fix the wiring ends with ferrules.

Connection via screw terminals:

- ▶ Insert the stripped cable ends (7 mm) in the guides of the cable glands.
- ▶ Fasten the screws with a screwdriver (max. tightening torque 0.5 Nm)

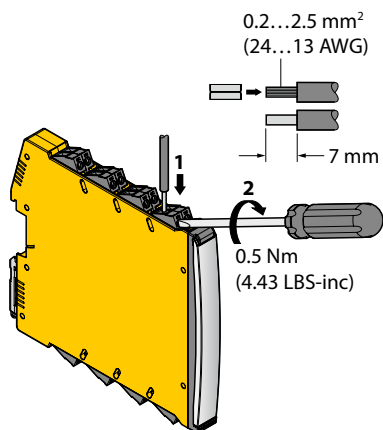

Fig. 2: Connection with screw terminals

Connection with spring-type terminals

- ▶ Push the opening lever with a suitable screwdriver.
- ▶ Insert the stripped cable ends (7 mm) in the guides of the spring-type terminals.
- ▶ Pull the screwdriver to fix the cable ends.

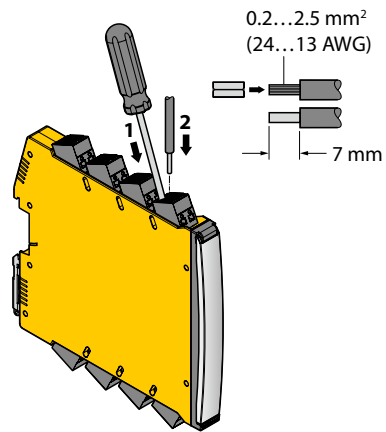

Fig. 3: Connection with spring-type terminals

- ▶ Make sure that only suitable equipment, e.g. sensors, are connected to the device (see „7 Connection and wiring diagrams“ on page 19).
- ▶ Make sure that a suitable power supply with the following characteristic is used:

Minimum voltage	10 VDC
Maximum voltage	30 VDC
Minimum power	4 W

6.2.1 Parameterization

The safety function depends on parametrization via rotary coded switches, dip-switches and wiring.

The device shall be locked against unintended operation/modification.

It is not permissible to configure the unit while it is operating in a safety application.

Messumformer-Speisetrenner / Isolating Transducer

Pin	Description	Pin	Description
5	[E1] Transmitter passive +	9	[A1A] Current Source+/ Sink-
6	[E1] Transmitter passive -	10	[A1A] Current Source-/ Sink+
7	[E1] Transmitter active +	11	[A2A] Voltage +
8	[E1] Transmitter active -	12	[A2A] Voltage -
		13	[A1D] Relay contact 1
		14	[A1D] Relay contact 2
		15	Ub +
		16	Ub -

Parameter	State
S1 [A _x A] analog output	current [A ₁ A] / voltage [A ₂ A]
S2 [A ₁ D] switching direction	under / over
S3 [A ₁ D] inverted mode	off / on

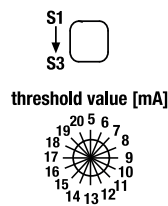

LED GN - power ON / Betriebsbereitschaft
 LED RD - fault in input circuit / Fehler im Eingangskreis
 LED YE - [A1D] output active / Ausgang aktiviert
 LED YE - [A1D] inverted mode / Ausgang invertiert

DIP switch	Comment
S1	AxA analog output (current [A1A]/voltage [A2A]): Select current output [A1A] or voltage output [A2A]
S2	A1D switching direction (under/over): Switching behavior of the relay output [A1D] Relay drops out when the input current exceeds (over) or drops out when the input current falls below (under) the set limit value for the input current [E1].
S3	A1D inverted mode (off/on): Direction of action of the relay output [A1D] Operating current behaviour (off) or closed-circuit current behaviour (on)

Rotary coded switch	Comment
5...20	From 5 mA to 20 mA ascending in 1 mA steps (16 steps)

LED	Color	Comment
PWR	Green	Device is ready for operation
B	Red flashing (NE44)	Wire break at input
	Off	OK
S	Red flashing (NE44)	Short circuit at input
	Off	OK
Rel	Yellow	Relay output: energized
	Off	Relay output: de-energized
Inv	Yellow	Relay output: switching function inverted
	Off	Relay output: switching function not inverted

Hysteresis: 200 μ A \pm 100 μ A

6.3 Operation

- ▶ If the device is used in low demand mode, proof tests shall be executed periodically according to T1.
- ▶ Ensure that the plug connections and cables are always in good condition.
- ▶ The device must be replaced immediately if the terminals are faulty or the device has any visible faults.
- ▶ If cleaning is required, do not use any liquid or statically charging cleaning agent. Perform proof tests after each cleaning.
- ▶ The proof test (see „9 Proof tests“ on page 20) shall be executed each time after installation and parameterization in order to check the requested function.
- ▶ No changes must be made to the parameterization during operation.
- ▶ The nominal voltage of the power supply of the device is 24 VDC. It must be operated with a range of 10...30 VDC.
- ▶ The burden at the analog output “current” must be less than 800 Ω , if the analog output “current” is used for safety applications.
- ▶ Passive 2-wire transmitters connected to the input circuit [E1] shall only impress currents that are valid according to the safety function.

6.4 After operation

- ▶ Undo the terminal connection on the device.
- ▶ Remove the device from its rail fixing as shown in the figure:

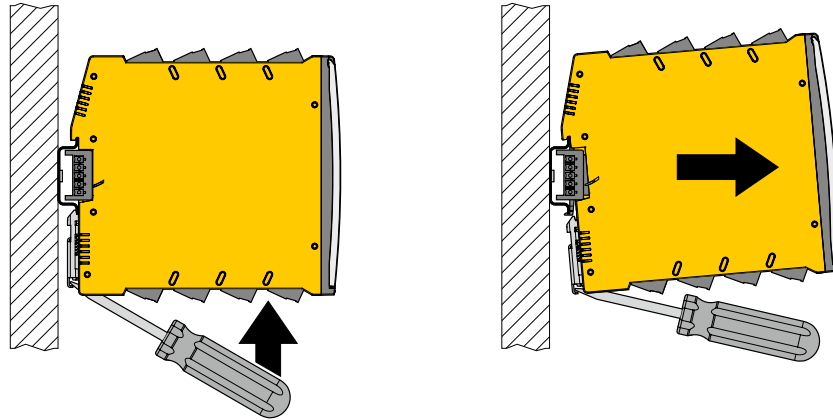

Fig. 4: Remove device

- ▶ Ensure the proper disposal of the device.

7 Connection and wiring diagrams

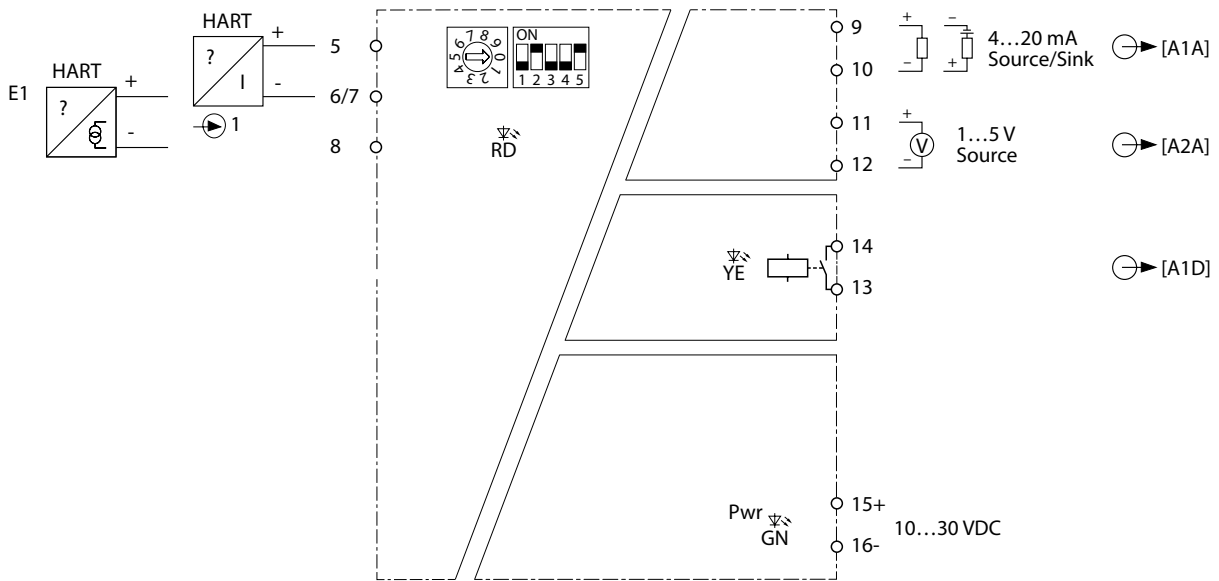

Fig. 5: Wiring diagram IM12-AI01-1I-1IU1R

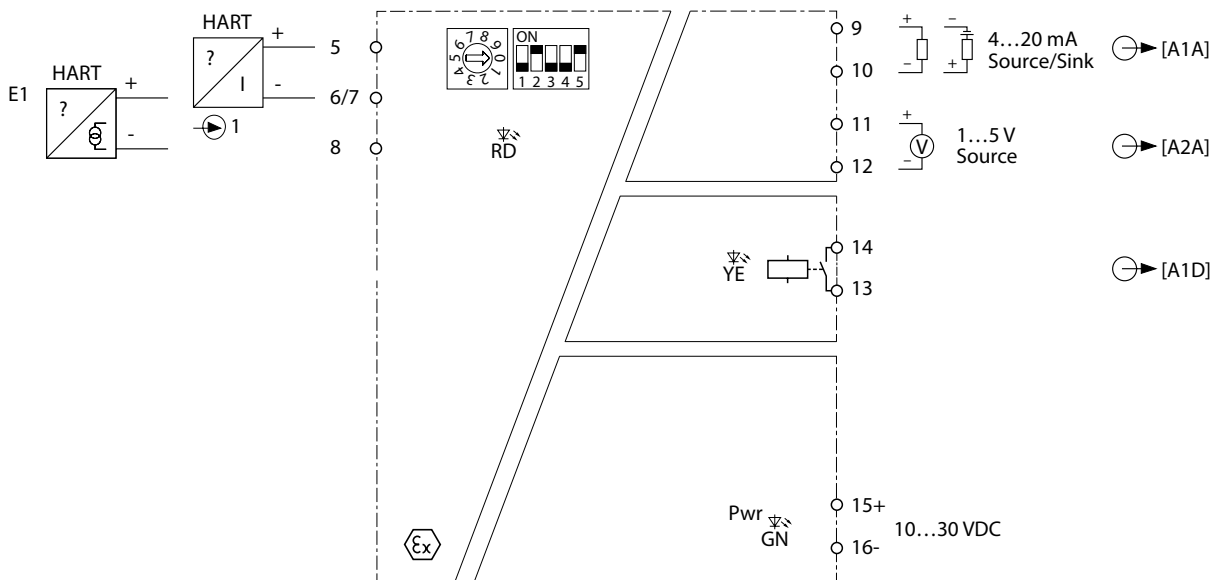

Fig. 6: Wiring diagram IMX12-AI01-1I-1IU1R

8 Terms and abbreviations

DC	Diagnostic Coverage
FIT	1 FIT is 1 failure per 10E09 hours
FMEDA	Failure Modes, Effects and Diagnostic Analysis
HFT	Hardware failure tolerance
λ_{AU}	Undetected Annunciation failure rate (per hour) Annunciation failures do not directly impact safety but impact the ability to detect a future fault (such as a fault in diagnostic circuit).
λ_{DD}	Detected dangerous failure rate (per hour)
λ_{DU}	Undetected dangerous failure rate (per hour)
λ_{SD}	Detected safe failure rate (per hour)
λ_{SU}	Undetected safe failure rate (per hour)
MTTR	Mean time to restoration (hour)
PFD_{avg}	Average probability of dangerous failure on demand
PFH	Probability of dangerous failure per hour
SFF	Safe Failure Fraction
SIL	Safety Integrity Level
T₁	Proof test interval (hour)
Type A	„Non-complex“ element (all failure modes are well defined); for details see 7.4.4.1.2 of IEC 61508-2
Type B	„Complex“ element (using micro controllers or programmable logic); for details see 7.4.4.1.3 of IEC 61508-2

9 Proof tests

Proof tests shall be undertaken to reveal dangerous faults which are undected by diagnostic tests. This means that it is necessary to specify how dangerous undetected faults which have been noted during the FMEDA can be detected during proof testing.

Ensure that the proof test is only carried out by qualified personnel.

A suggested proof test consists of the following steps:

Step	Action
1.	Bypass the safety functions and take appropriate action to avoid a false trip.
2.	Provide appropriate input-/control signals to the interface modules and verify the expected signal input/output conditions for the interfaces.
3.	Verify if internal fault detection is working in case it is activated.
4.	Provide appropriate input-/control signals to the interface modules and verify that the safety function is carried out correctly.
5.	Remove the bypass and otherwise restore normal operation.

Once the test has been completed, document and archive the results.

Safety function	Proof test coverage (PTC)
E1 → A1A	95.12
E1 → A2A	95.06
E1 → A1D with current output	96.83
E1 → A1D with voltage output	96.81

10 Certificate

These products are certified by SGS-Saar for the use in safety-related applications. The certificate can be found under the following Link: www.turck.com

11 Document history

Document Version	Date	Modifications
1.0	2023-03-01	Initial version
2.0	2026-01-29	– SC3 added – Description added: capability of use in a 1oo2 architecture up to SIL 3 with a hardware fault tolerance HFT = 1, depending on the application – SIL card removed

TURCK

Your Global Automation Partner

Over 30 subsidiaries and
60 representations worldwide!

100047198 | 2026/01



www.turck.com