

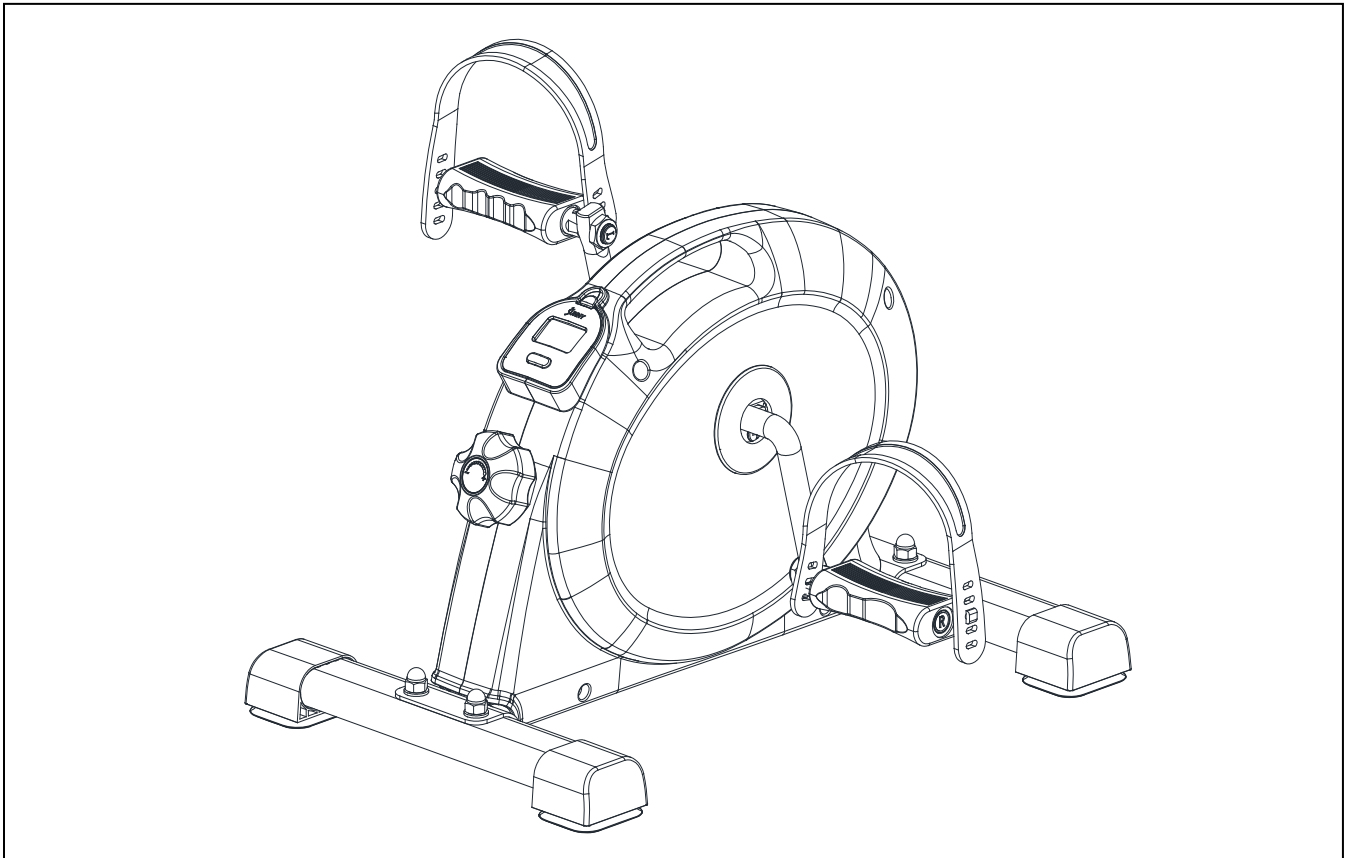

# UNDER DESK SMART MINI EXERCISE BIKE (WHITE)

## SF-B023005WHT

### USER MANUAL



**DO NOT STAND ON THE UNIT.**

**IMPORTANT!** Please retain owner's manual for maintenance and adjustment instructions. Your satisfaction is very important to us, **PLEASE DO NOT RETURN UNTIL YOU HAVE CONTACTED US:** [support@sunnyhealthfitness.com](mailto:support@sunnyhealthfitness.com) or 1- 877 - 90SUNNY (877-907-8669).



[WWW.SUNNYHEALTHFITNESS.COM](http://WWW.SUNNYHEALTHFITNESS.COM)

# **IMPORTANT SAFETY INFORMATION**

We thank you for choosing our product. To ensure your safety and health, please use this equipment correctly. It is important to read this entire manual before assembling and using the equipment. Safe and effective use can only be achieved if the equipment is assembled, maintained, and used properly. It is your responsibility to ensure that all users of the equipment are informed of all warnings and precautions.

1. Before starting any exercise program, you should consult your physician to determine if you have any medical or physical conditions that could put your health and safety at risk or prevent you from using the equipment properly. Your physician's advice is essential if you are taking medication that affects your heart rate, blood pressure, or cholesterol level.
2. Be aware of your body's signals. Incorrect or excessive exercise can damage your health. Stop exercising if you experience any of the following symptoms: pain, tightness in your chest, irregular heartbeat, shortness of breath, lightheadedness, dizziness, or feelings of nausea. If you do experience any of these conditions, you should consult your physician before continuing with your exercise program.
3. Keep children and pets away from the equipment. The equipment is designed for adult use only.
4. Use the equipment on a solid, flat level surface with a protective cover for your floor or carpet. To ensure safety, the equipment should have at least 2 feet (60 CM) of free space all around it.
5. Ensure that all nuts and bolts are securely tightened before using the equipment. The safety of the equipment can only be maintained if it is regularly examined for damage and/or wear and tear.
6. Always use the equipment as indicated. If you find any defective components while assembling or checking the equipment, or if you hear any unusual noises coming from the equipment during exercise, discontinue use of the equipment immediately and do not use until the problem has been rectified.
7. Wear suitable clothing while using the equipment. Avoid wearing loose clothing that may become entangled in the equipment.
8. Do not place fingers or objects into the moving parts of the equipment.
9. The equipment is not suitable for therapeutic use.
10. To avoid bodily injury and/or damage to the product or property, proper lifting and moving are required.
11. Your product is intended for use in cool, dry conditions. You should avoid storage in extreme cold, hot, or damp areas as this may lead to corrosion and other related problems.
12. This equipment is designed for indoor and home use only; it is not intended for commercial use!

# PRE-ASSEMBLY CHECK LIST

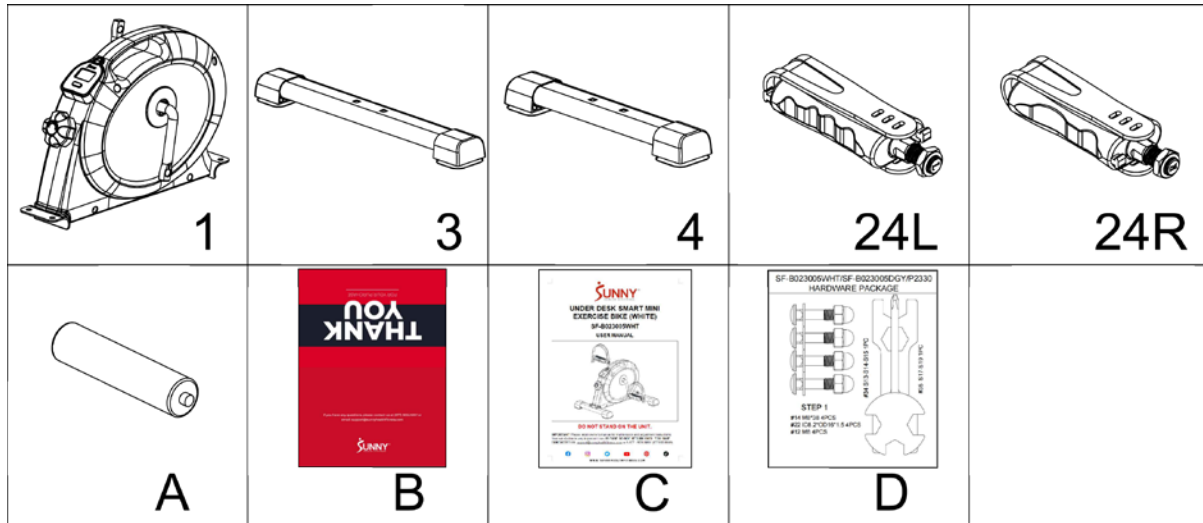

No.	Description	Spec	Qty.
1	Main Frame		1
3	Front Stabilizer		1
4	Rear Stabilizer		1
24L	Left Pedal		1
24R	Right Pedal		1
A	Battery	AAA, 1.5V	2
B	Thank You Card		1
C	Manual		1
D	Hardware Package		1

# **HARDWARE PACKAGE**

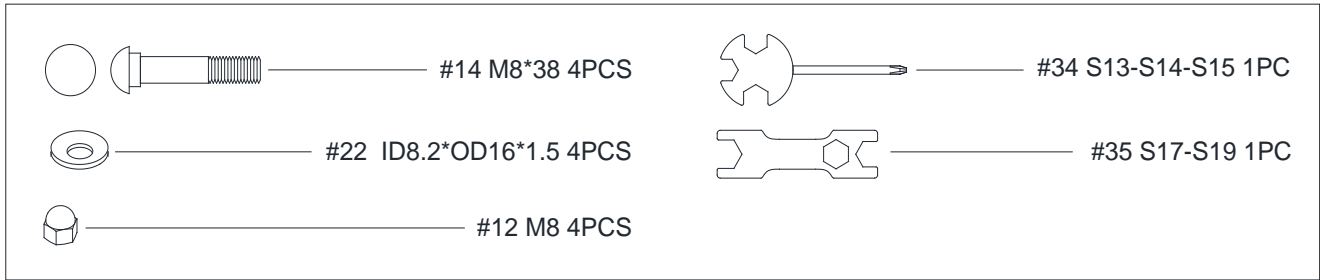

## **Ordering Replacement Parts (U.S. and Canadian Customers only)**

Please provide the following information in order for us to accurately identify the part(s) needed:

- ✓ The model number (found on cover of manual)
- ✓ The product name (found on cover of manual)
- ✓ The part number found on the “EXPLODED DIAGRAM” (page 13) and “PARTS LIST” (page 12).

Please contact us at [support@sunnyhealthfitness.com](mailto:support@sunnyhealthfitness.com) or 1-877-90SUNNY (877-907-8669).

# ASSEMBLY INSTRUCTIONS

We value your experience using Sunny Health and Fitness products. For assistance with parts or troubleshooting, please contact us at [support@sunnyhealthfitness.com](mailto:support@sunnyhealthfitness.com) or 1-877-90SUNNY (877-907-8669).

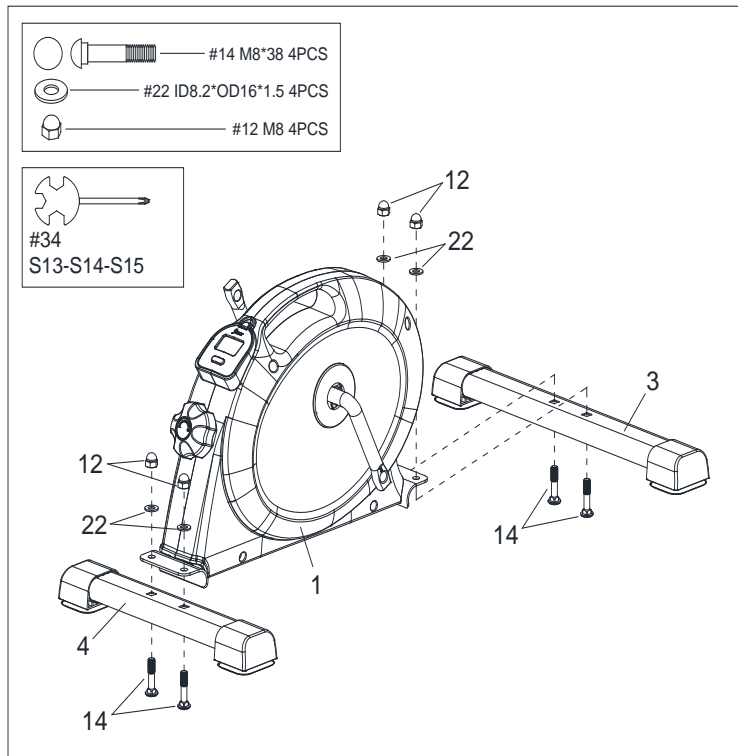

## STEP 1:

Attach **Rear Stabilizer (No. 4)** to the **Main Frame (No. 1)** with 2 **Carriage Bolts (No. 14)**, 2 **Flat Washers (No. 22)**, and 2 **High Cap Nuts (No. 12)**. Tighten and secure with **Spanner (No. 34)**.

Attach **Front Stabilizer (No. 3)** to the **Main Frame (No. 1)** with 2 **Carriage Bolts (No. 14)**, 2 **Washers (No. 22)**, and 2 **High Cap Nuts (No. 12)**. Tighten and secure with **Spanner (No. 34)**.

We value your experience using Sunny Health and Fitness products. For assistance with parts or troubleshooting, please contact us at [support@sunnyhealthfitness.com](mailto:support@sunnyhealthfitness.com) or 1-877-90SUNNY (877-907-8669).

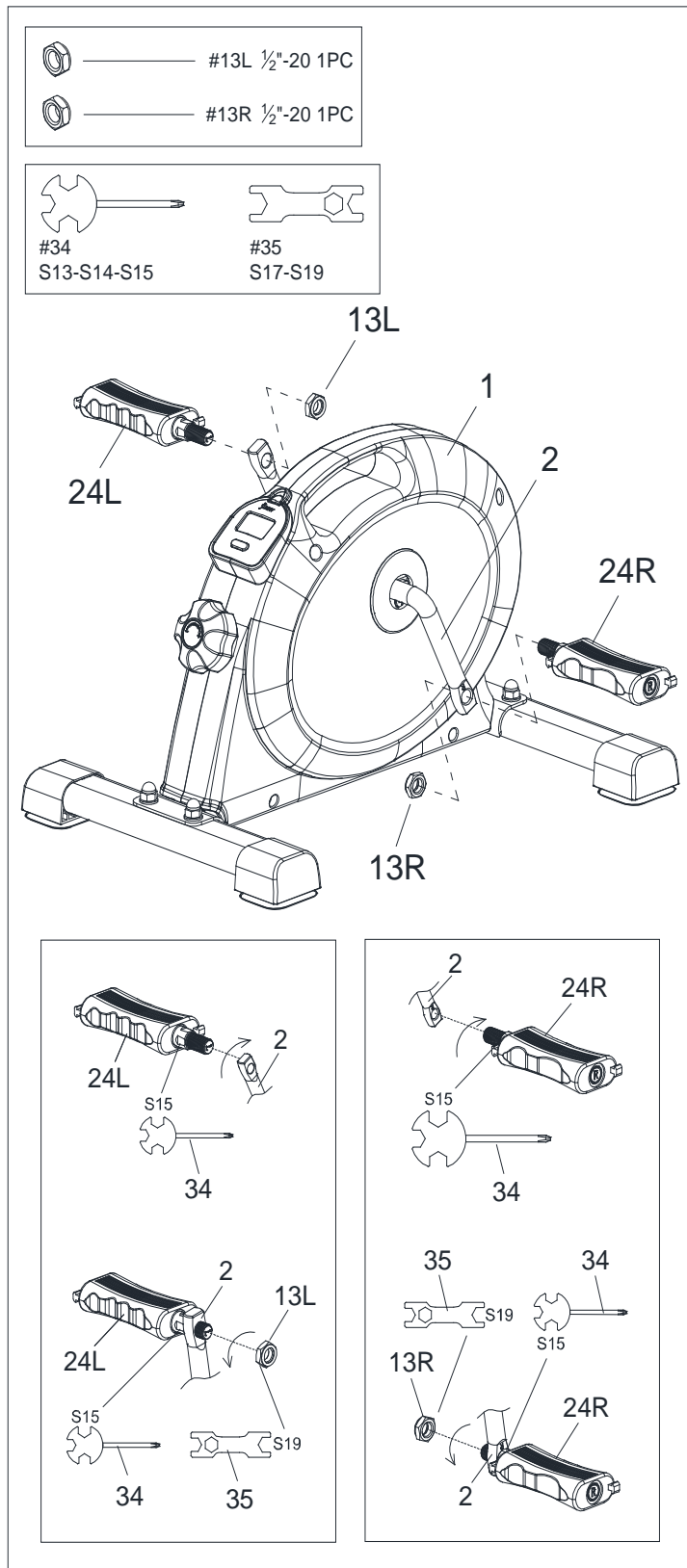

## STEP 2:

**NOTE:** The **Left & Right Pedals (No. 24L & No. 24R)** are marked "L" and "R" for Left and Right.

**WARNING!** Read instructions carefully as improper assembly may cause permanent damage to your bike.

Remove the **Left & Right Nylon Nuts (No. 13L & No. 13R)** located on the **Left & Right Pedals (No. 24L & No. 24R)**.

Align the **Left Pedal (No. 24L)** with the left side of **Crank Arm (No. 2)** at 90°. Gently insert the **Left Pedal (No. 24L)** into the **Crank Arm (No. 2)** and turn the **Left Pedal (No. 24L)** counter-clockwise as tightly as you can with your hand. Use **Spanner (No. 34)** to tighten and secure.

Turn the **Left Nylon Nut (No. 13L)** clockwise as tightly as you can with your hand. Use **Spanner (No. 34)** to hold the pedal bolt on the **Left Pedal (No. 24L)** and use **Spanner (No. 35)** to turn the **Left Nylon Nut (No. 13L)** clockwise at the same time, until it is tightened on to the **Crank Arm (No. 2)**.

Align the **Right Pedal (No. 24R)** with the right side of **Crank Arm (No. 2)** at 90°. Gently insert the **Right Pedal (No. 24R)** into the **Crank Arm (No. 2)** and turn the **Right Pedal (No. 24R)** clockwise as tightly as you can with your hand. Use **Spanner (No. 34)** to tighten and secure.

Turn the **Right Nylon Nut (No. 13R)** counter-clockwise as tightly as you can with your hand. Use **Spanner (No. 34)** to hold the pedal bolt on the **Right Pedal (No. 24R)** and use **Spanner (No. 35)** to turn the **Right Nylon Nut (No. 13R)** counter-clockwise at the same time, until it is tightened on to the **Crank Arm (No. 2)**.

We value your experience using Sunny Health and Fitness products. For assistance with parts or troubleshooting, please contact us at [support@sunnyhealthfitness.com](mailto:support@sunnyhealthfitness.com) or 1-877-90SUNNY (877-907-8669).

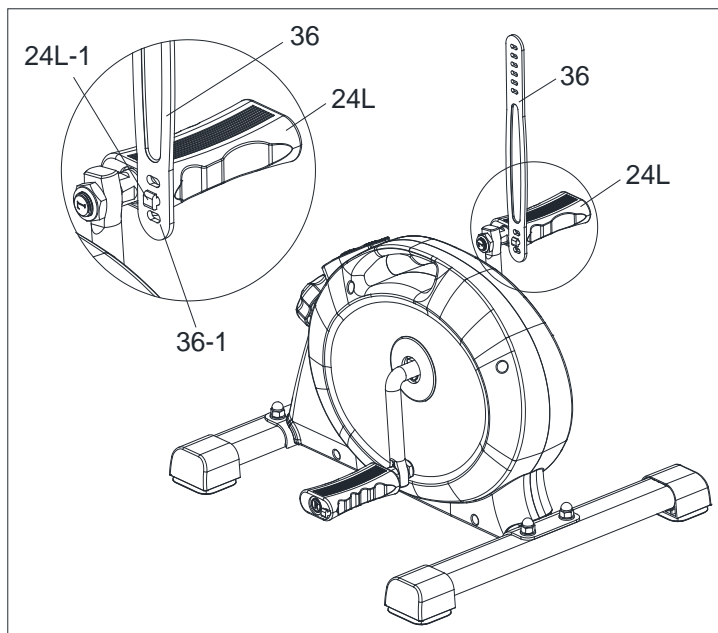

### STEP 3:

Insert the fixing hole (36-1) of the **Pedal Strap (No. 36)** into the groove (24L-1) of the **Left Pedal (No. 24L)**.

Insert the fixing hole (36-2) of the **Pedal Strap (No. 36)** into the groove (24L-2) of the **Left Pedal (No. 24L)**.

**NOTE :** The position of fixing holes and groove can be adjusted according to the size of your feet.

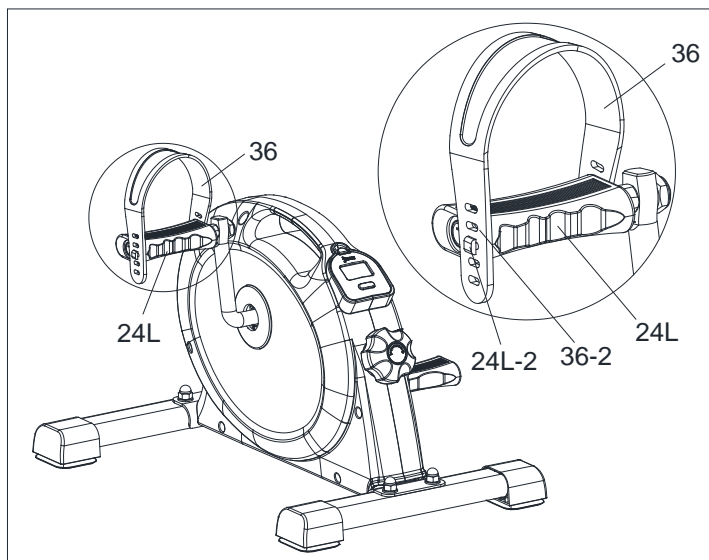

We value your experience using Sunny Health and Fitness products. For assistance with parts or troubleshooting, please contact us at [support@sunnyhealthfitness.com](mailto:support@sunnyhealthfitness.com) or 1-877-90SUNNY (877-907-8669).

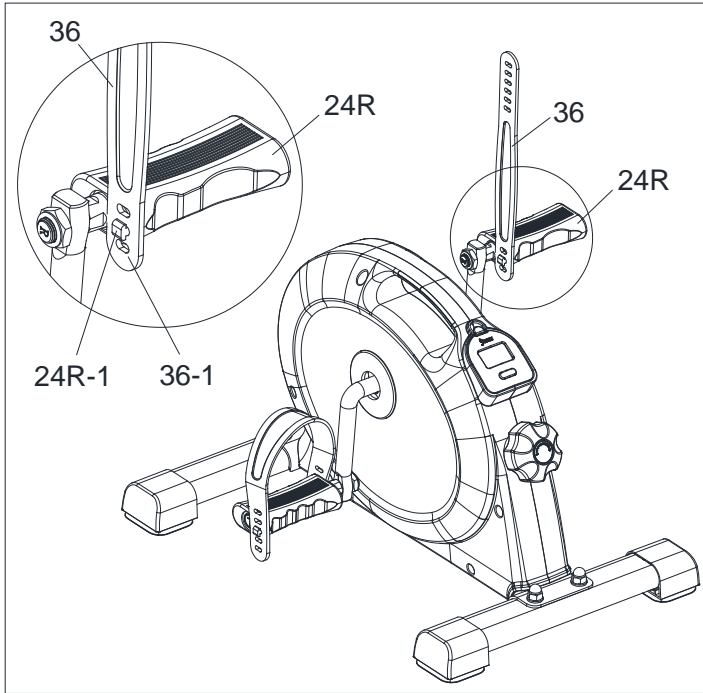

**STEP 4:**

Insert the fixing hole (36-1) of the **Pedal Strap (No. 36)** into the groove (24R-1) of the **Left Pedal (No. 24R)**.

Insert the fixing hole (36-2) of the **Pedal Strap (No. 36)** into the groove (24R-2) of the **Left Pedal (No. 24R)**.

**NOTE :** The position of fixing holes and groove can be adjusted according to the size of your feet.

*The assembly is complete!*

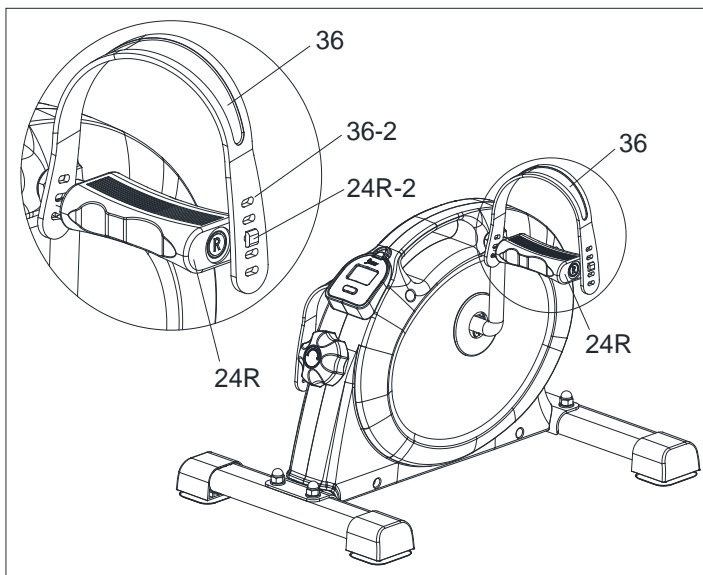

# **BATTERY INSTALLATION & REPLACEMENT**

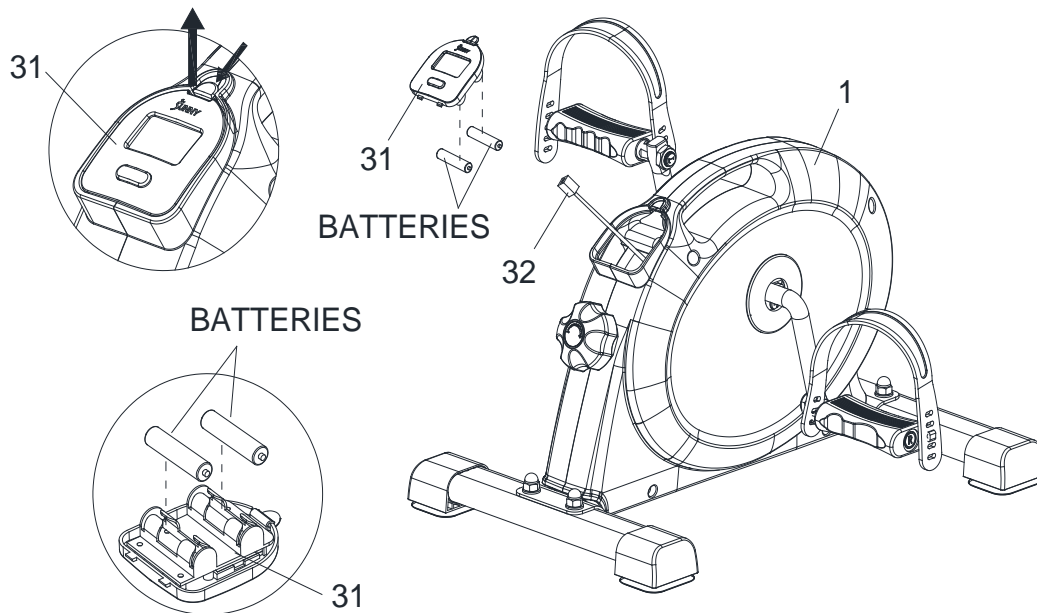

## **BATTERY INSTALLATION:**

1. Take out 2 AAA batteries from the manual bag.
2. Remove the **Meter (No. 31)** from **Main Frame (No. 1)**. Then disconnect the **Sensor Wire (No. 32)** from the **Meter (No. 31)**.
3. Install 2 AAA batteries into the battery case on the back of the **Meter (No. 31)**. Pay attention to the battery + and – poles before installing.
4. Insert the **Sensor Wire (No. 32)** into the hole on the back of **Meter (No. 31)**.
5. Attach the **Meter (No. 31)** onto the **Main Frame (No. 1)**.

*The installation is complete!*

## **BATTERY REPLACEMENT:**

1. Remove the **Meter (No. 31)** from **Main Frame (No. 1)**. Then disconnect the **Sensor Wire (No. 32)** from the **Meter (No. 31)**.
2. Remove the 2 old AAA batteries from the battery case and install 2 new AAA batteries into the battery case on the back of the **Meter (No. 31)**. Pay attention to the battery + and – poles before installing.
3. Insert the **Sensor Wire (No. 32)** into the hole on the back of **Meter (No. 31)**.
4. Attach the **Meter (No. 31)** onto the **Main Frame (No. 1)**.

*The replacement is complete!*

**NOTE:** Dispose battery according to your state and regional guidelines.

# EXERCISE METER

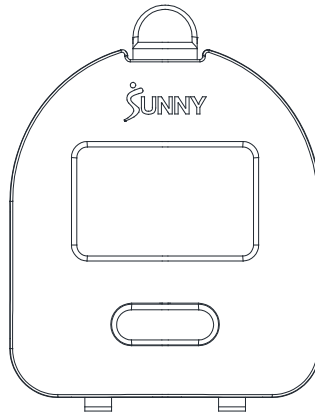

## **KEY GUIDE:**

### **MODE:**

1. Press the Mode key to select the function you want.
2. Press and hold the key for 3 seconds to reset the value to zero (without resetting TOT).

### **FUNCTIONS:**

**TMR (TIME):** Press the key until "TMR" is displayed on the screen, the meter will display the time elapsed during exercise.

**SPD (SPEED):** Press the key until "SPD" is displayed on the screen, the meter will display the speed during exercise.

**DIS (DISTANCE):** Press the key until "DIS" is displayed on the screen, the meter will display the distance travelled during exercise.

**CAL (CALORIE):** Press the key until "CAL" is displayed on the screen, the meter will display the calories burned during exercise.

**ODO:** Counts the total distance from when batteries was installed. If the batteries are replaced, the value will reset to zero.

### **NOTE:**

1. The meter will shut off automatically, if there is no input for 4 minutes, all function values will be saved. You can press any key or restart exercising to wake up the meter.
2. If the display on the meter does not show properly, please re-install or replace the batteries.
3. Battery spec: 1.5V AAA\*2pcs.

# ADJUSTMENTS & USAGE GUIDE

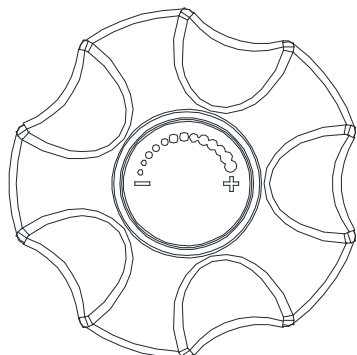

## ADJUSTING THE TENSION

Adjust the tension by rotating the **Tension Control Knob (No. 28)** clockwise to increase the level of resistance. Rotate the **Tension Control Knob (No. 28)** counter-clockwise to decrease the level of resistance.

**NOTE:** The **Tension Control Knob (No. 28)** can be stepless adjustment, just turn it clockwise to the end or counter-clockwise to the end.

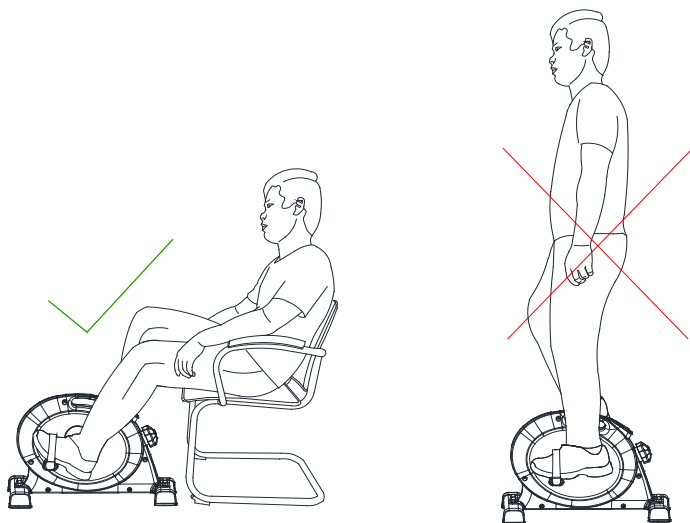

## WARNING

The machine is intended to be used in a sitting position only, do not stand on the machine.

Failure to follow all warnings and instructions could result in serious injury or death.

**USE ONLY WHILE SITTING.  
DO NOT STAND ON THE  
MACHINE!**

## APP CONNECTION:

1. Scan the QR code below to download the SunnyFit app onto your mobile device.



2. If this is your first time using the SunnyFit app, follow the in-app instructions to register for your free SunnyFit account and log in.



3. Ensure that the Bluetooth function is turned on from your mobile device.
4. To connect the equipment to the SunnyFit app:
  - a. From the “Workout” tab, press on the “Search” button to search for your equipment.
  - b. Once your equipment appears on the list, tap the “Select” button to confirm.
  - c. **NOTE:** If your equipment does not appear on the "Searching for Equipment" list, check the METER on your equipment to ensure that it is not in sleep mode and your phone's Bluetooth function is on, then tap "Retry" to search again.
  - d. Once your equipment shows up on the “Workout” tab as “Currently Selected,” your equipment is now ready to display, track, and record your equipment’s workout stats on the app!
5. If you are unable to replicate these steps, or have any other issues with the SunnyFit app, please contact SunnyFit support at [support@sunnyfit.com](mailto:support@sunnyfit.com), or use the in-app “Contact Us” form to request support (“Me” tab -> “Contact Us”).

# PARTS LIST

No.	Description	Spec.	Qty.	No.	Description	Spec.	Qty.
1	Main Frame		1	20	Screw	ST4.2*15	5
2	Crank Arm		1	21	Screw	ST4.2*13	4
3	Front Stabilizer		1	22	Flat Washer	ID8.2*OD16*1.5	4
4	Rear Stabilizer		1	23L	Left Belt Cover		1
5	Adjusting Plate		1	23R	Right Belt Cover		1
6	Fixing Plate		1	24L	Left Pedal		1
7	Belt Wheel		1	24R	Right Pedal		1
8	Spring		1	25	End Cap	25*50	4
9	Adjusting Bolt		1	26	Bearing Clamp	φ55*5	2
10	Spring Clip		1	27	Flywheel Clamp	φ33.5*φ16*4	1
11	Outer Circlip		1	28	Tension Control Knob	φ60*φ8*41	1
12	High Cap Nut	M8	4	29	Belt	L550*W20	1
13L	Left Nylon Nut	1/2"-20	1	30	End Cap	φ70*φ29*12	2
13R	Right Nylon Nut	1/2"-20	1	31	Meter	XT-2366	1
14	Carriage Bolt	M8*38	4	32	Sensor Wire	Line: 200mm	1
15	Screw	M4*8	3	33	Knob Sticker	φ21.5	1
16	Screw	M6*12	8	34	Spanner	S13-S14-S15	1
17	Screw	M6*15	3	35	Spanner	S17-S19	1
18	Screw	M6*15	1	36	Pedal Strap		2
19	Screw	ST2.9*10	2				

# EXPLODED DIAGRAM

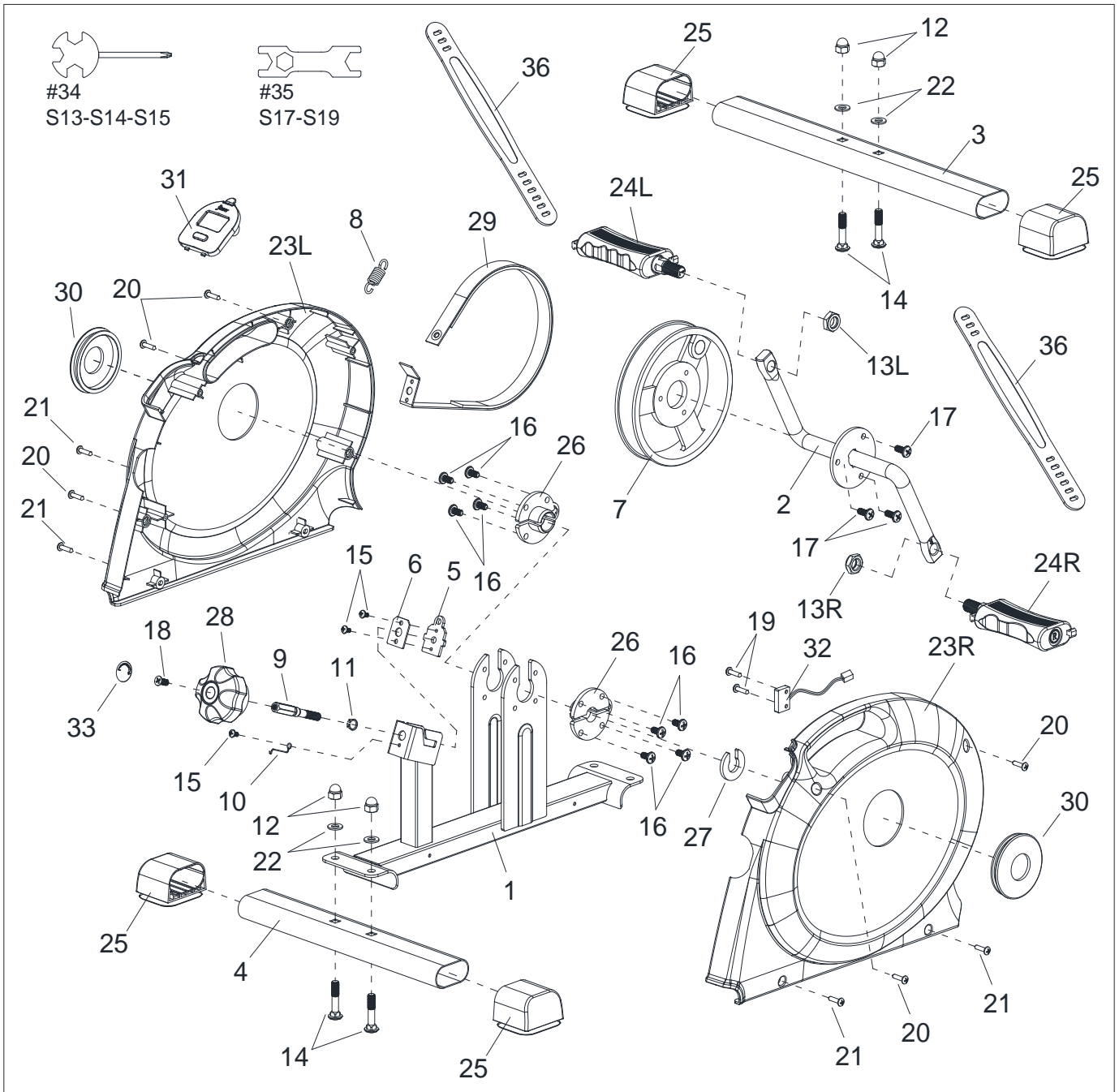

Version: 1.0

# CONNECT WITH US

FOR FITNESS ARTICLES, VIDEOS & WORKOUTS



@SUNNYHEALTHANDFITNESS



@SUNNYHEALTHFITNESS



@SUNNYHEALTHFIT



/SUNNYHEALTHFITNESS



/SUNNYHEALTHANDFITNESS



@SUNNYHEALTHFITNESS

[WWW.SUNNYHEALTHFITNESS.COM](http://WWW.SUNNYHEALTHFITNESS.COM)