



Meaningful Innovation.

WEEE Number: 80133970

INSTRUCTION MANUAL

LED FLOOD LIGHT

TECHNICAL DATA

MODEL	VT-44035	VT-44055	VT-44104	VT-44204
SKU	23599	23688, 23600 23689, 23690	23440,23441 23442,23443	23601 23602, 23603
POWER	30W	50W	100W	200W
LUMENS	2505Lm	4270Lm	8700 Lm	17540Lm
COLOUR TEMPERATURE	3000K	4000K 6500K	4000K 6500K	4000K 6500K
INPUT VOLTAGE	AC: 220-240V, 50Hz			
DF	>0.9			
CRI	70			
LIFE SPAN	25,000 Hours			
ON/OFF CYCLE	15,000 Times			
BEAM ANGLE	115°			
OPERATION TEMPERATURE	-20°C to +40°C			
BODY TYPE	Aluminium			
MAX. MOUNTING HEIGHT	<5M			
NET WEIGHT	0.35Kg	0.48Kg	0.97Kg	2.5Kg
PROJECTED AREA (mm ²)	25168.5	31011.5	61473.75	140673.75
DIMENSION	164.5x34x- 153mm	183.5x34x- 169mm	253.5x242.5 x40mm	402.5x349x5x- 44mm



IP65
RATING

05 YEAR
WARRANTY*

PRO
SERIES



*This product contains a light source of energy efficiency class<F>,where <F> shall be replaced by the energy class of the contained light source.

INTRODUCTION & WARRANTY

Thank you for selecting and buying V-TAC product. V-TAC will serve you the best. Please read these instructions carefully before starting the installation and keep this manual handy for future reference. If you have any another query, please contact our dealer or local vendor from whom you have purchased the product. They are trained and ready to serve you at the best. The warranty is valid for 5 years from the date of purchase. The warranty does not apply to damage caused by incorrect installation or abnormal wear and tear. The company gives no warranty against damage to any surface due to incorrect removal and installation of the product. The products are suitable for 10-12 Hours Daily operation. Usage of product for 24 Hours a day would void the warranty. This product is warranted for manufacturing defects only.

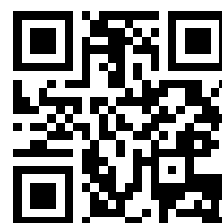



MULTI-LANGUAGE
MANUAL QR CODE

Please scan the QR code to access the manual in multiple languages.

In case of any query/issue with the product, please reach out to us at: support@v-tac.eu
For More products range, inquiry please contact our distributor or nearest dealers.
V-TAC EUROPE LTD. Bulgaria, Plovdiv 4000, bul.L.Karavelow 9B

WARNING

1. Please make sure to turn off the power before starting the installation.
2. Installation must be performed by a qualified electrician.
3. The light source contained in this luminaire shall only be replaced by the manufacturer or his service agent or a similar qualified person.
4. The external flexible cable or cord of this luminaire cannot be replaced; if the cord is damaged, the luminaire shall be destroyed.
5. Replace any cracked protective shield. 
6. Terminal block not included.
7. Proper grounding should be ensured throughout the installation.
8. Minimum distance from lighted objects 1m. 
9. For outdoor use.

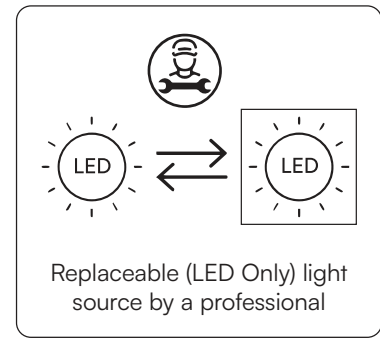

NOTE: To reduce the risk of strangulation the flexible wiring connected to this luminaire shall be effectively fixed to the wall if the wiring is within arm's reach.

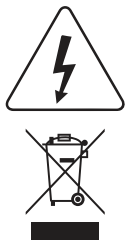

Caution, risk of electric shock.

This marking indicates that this product should not be disposed of with other household wastes.



FR

Cet appareil, ses accessoires et cordons se recyclent

À DÉPOSER EN MAGASIN



OU

À DÉPOSER EN DÉCHÈTERIE



Points de collecte sur www.quefairedemesdechets.fr
Privilégiez la réparation ou le don de votre appareil !

INSTALLATION DIAGRAM

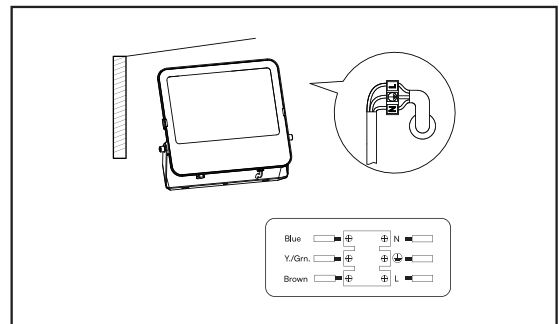
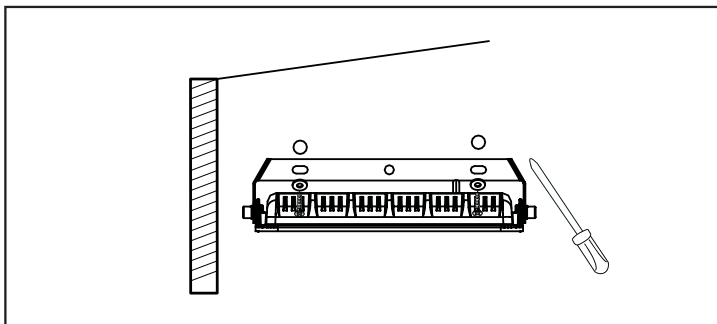
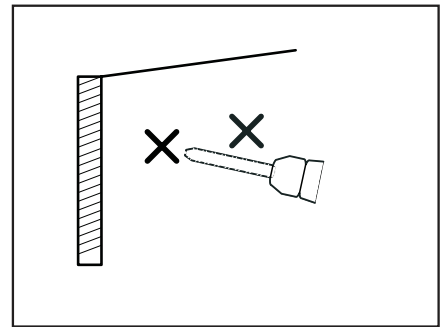
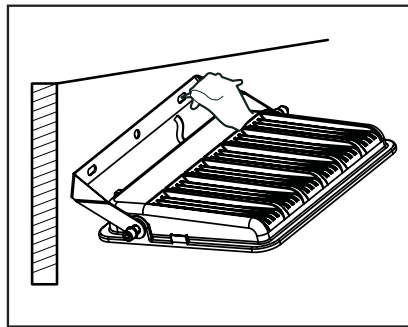
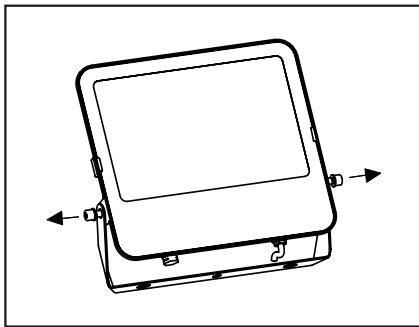

INSTALLATION INSTRUCTION

- DO NOT USE IN AREAS WITH LIMITED VENTILATION OR OUTSIDE THE RATED AMBIENT TEMPERATURE RANGE. *CONNECT WITH WATERPROOF CABLE HOUSE ONLY. *ENSURE ELECTRICITY IS SWITCH OFF BEFORE INSTALLATION.
- Please do not mount to a surface that is prone to vibrations.*
Remove the screw and the bracket afterward. (Figure 1) Before drilling, mark the hole position for fixing the bracket onto the wall (Screw not supplied). (Figure 2)
- Screw the retaining bracket to the wall with a suitable quantity of screws. (Figure 4)
- Mount the bracket back to the fixture. Adjust the floodlight according to the desired position. Tighten the screw. (Figure 5) Connect your main cable (HO5RN-F3G1.0mm2 Recommended) with the input lead of our product through the waterproof junction box. Note, the line (-) of the lead. (Need to use the junction box of IP65 or above, ensure to tighten the waterproof screw) Switch on the power to make sure if the product is working.

DISASSEMBLY DIAGRAM

For Market surveillance team only

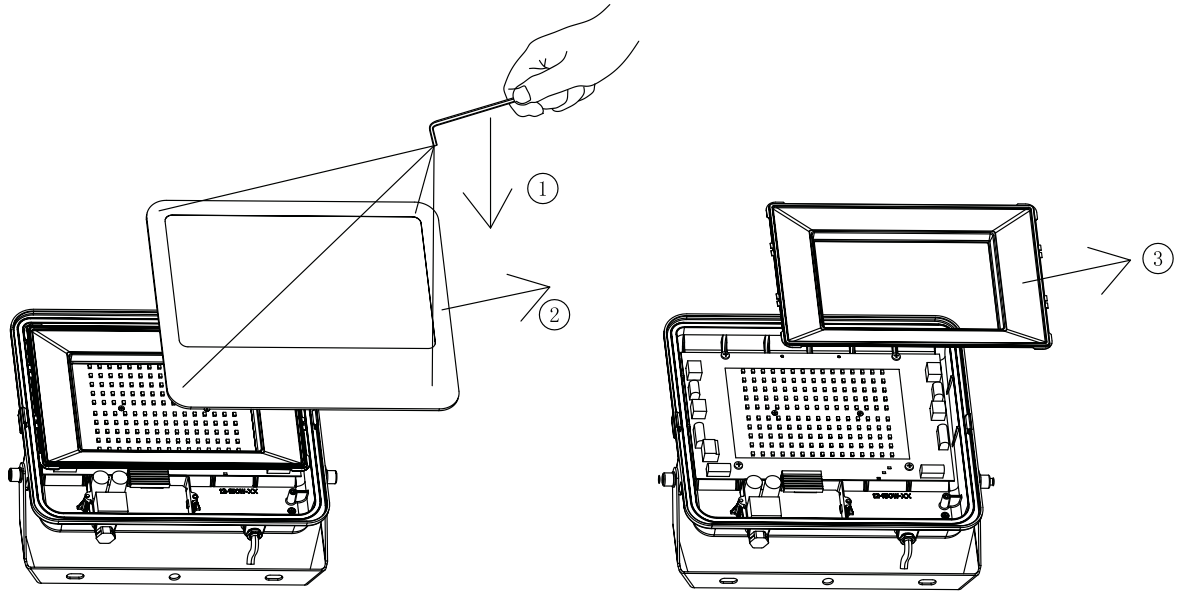

Note: Light source removal will void the warranty

RoHS



UK
CA



Not Dimmable

