

VEVOR

Upgrade · The Home Creator Way

Livestock Stand

Model: 51*23inch-B

Model: 51*23inch-B

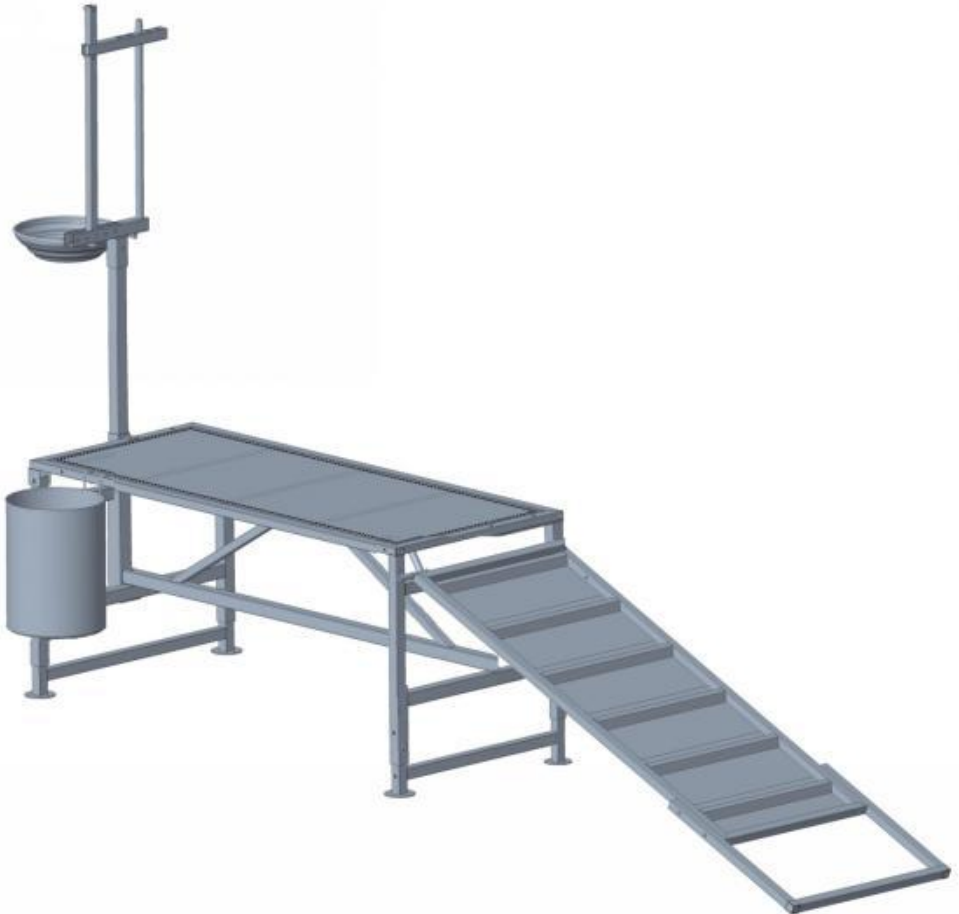

This is the original instruction, please read all manual instructions carefully before operating. VEVOR reserves a clear interpretation of our user manual. The appearance of the product shall be subject to the product you received. Please forgive us that we won't inform you again if there are any technology or software updates on our product.

SAFETY INSTRUCTIONS

WARNING:

Read this material before using this product. Failure to do so can result in serious injury.

Assembly precautions

1. Assemble only according to these instructions. Improper assembly can create hazards.
2. Wear ANSI-approved safety goggles and heavy-duty work gloves during assembly.
3. Keep the assembly area clean and well-lit.
4. Keep bystanders out of the area during assembly.
5. Do not assemble if tired or when under the influence of alcohol, drugs or medication.
6. The product capabilities apply to properly and completely assembled products only.
7. Assemble on a flat, level, hard and smooth surface capable of safely supporting the Livestock Stand.
8. For additional information regarding the parts listed in the following pages, please refer to the Assembly Diagram of this manual. Unwrap and separate all parts in a clean work area.
9. The product complies with relevant standards and regulations. Installation of this device must comply with all applicable regulations, and it should only be operated in well-ventilated areas. Please read the user manual before installing and using this equipment.
10. This appliance is not intended for use by persons (including children) with reduced physical, sensory or mental capabilities, or lack of experience and knowledge, unless they have been given supervision or instruction concerning use of the appliance by a person responsible for their safety.
11. This appliance is intended to be used in household and similar applications such as:

- farm houses;
12. Please properly keep product. Check whether the product is abnormal before use. If it is abnormal, please stop using it











Use precautions

1. DO NOT SIT OR STAND ON THIS ITEM.
2. This product is not a toy. Do not allow children to play with or near this item.
3. Do not exceed specified weight capacities.
4. Use as intended only.
5. Inspect before every use; do not use if parts are loose or damaged.

SAVE THIS MANUAL

PARTS LIST

No.	Part	Name	Qty.
1		Movable rack	1
2		Fixed rack	1
3		Long pole	1
4		Fixed rod	1
5		Tabletop	1
6		Adjustable leg A	2
7		Adjustable leg B	1
7-1		Adjustable leg B	1
8		Circular hoop	1
9		Basin	1

No.	Part	Name	Qty.
10		Tool bag	1
11		Connecting rod	1
12		Ramp	1
13		U-shaped pole	1
A		Quick-release pin	5
B		Plastic knob	7
C		Screw M8*45mm	8
D		Nut M8	16
E		Quick-release pin	2
F		Screw M8*60mm	4
G		Screw M8*80mm	2

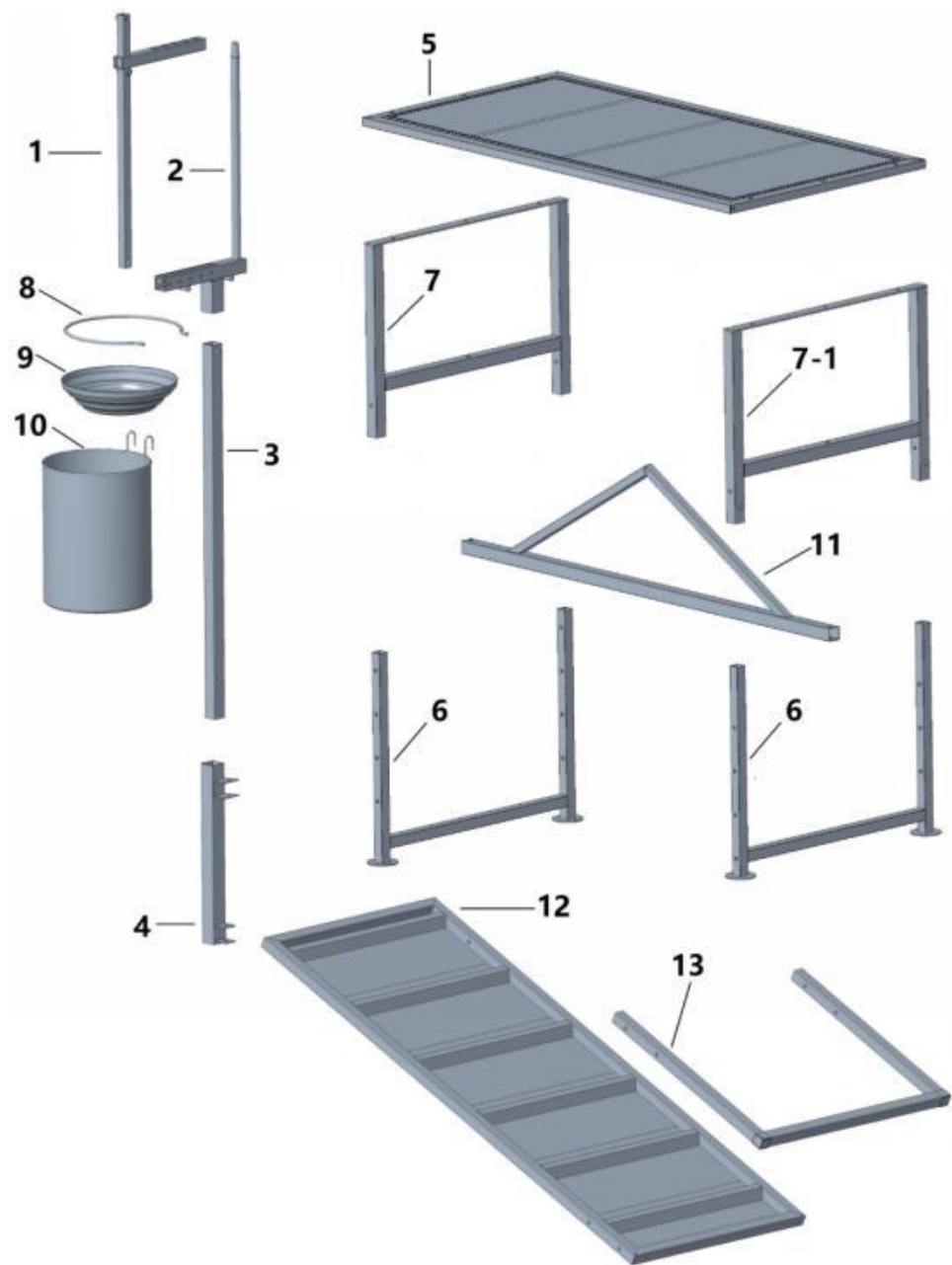

ASSEMBLY STEP

STEP 1

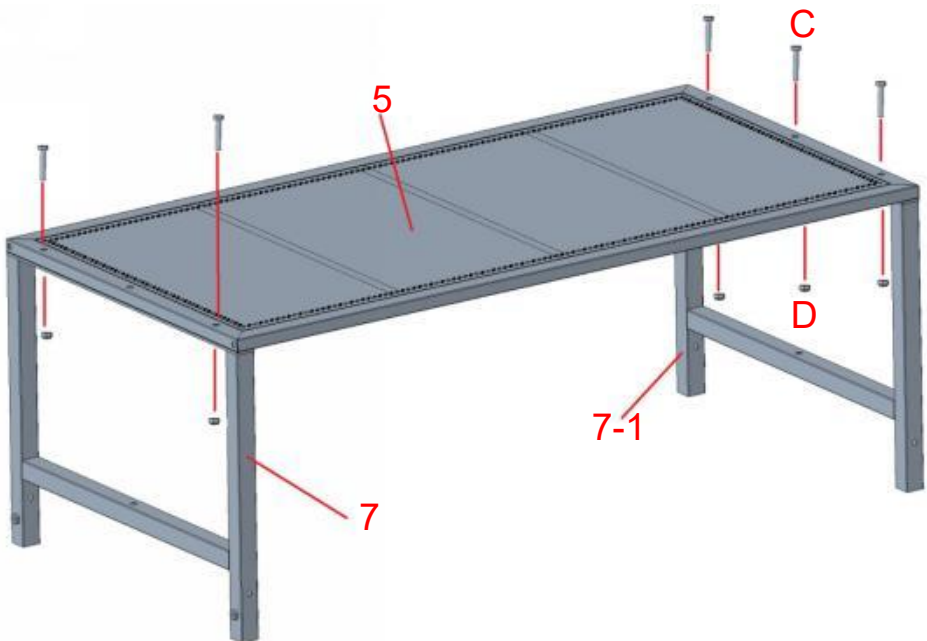

Secure the adjustable leg B(7) to the tabletop(5) with screws(C).

STEP 2



M8*35mm



C x2



D x4

M8*70mm



F x2

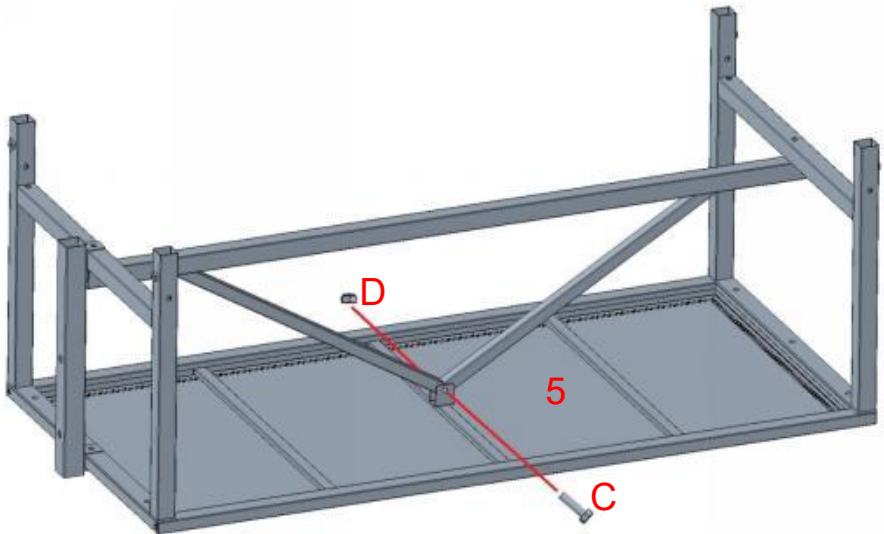
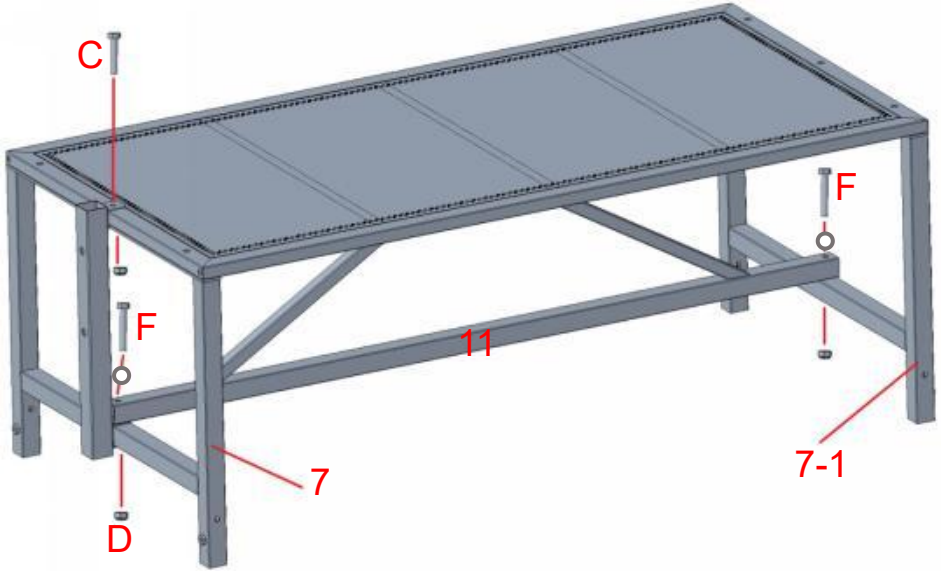

Secure the fixed rod(4) and connecting rod(11) to the tabletop(5) with screws(C and H).

STEP 3

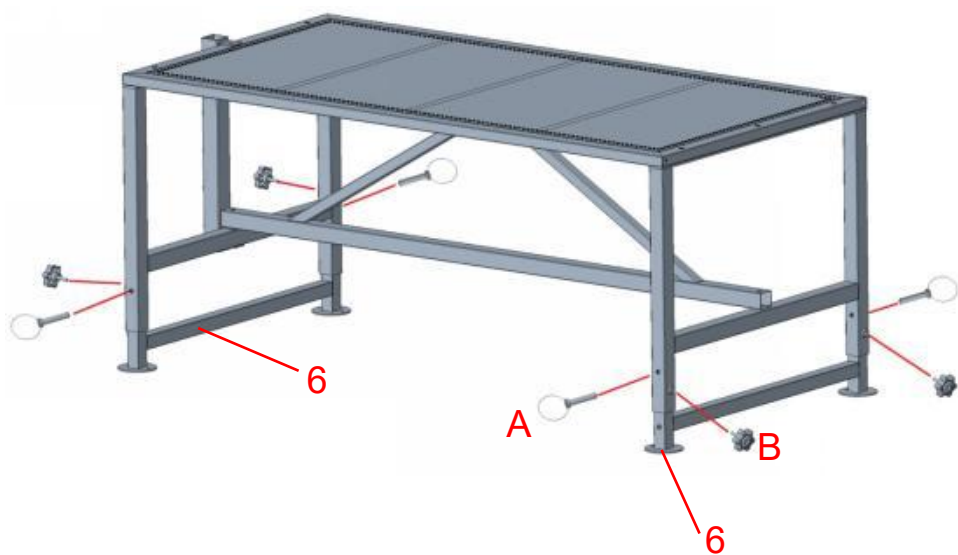
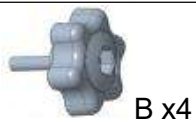

Insert the adjustable leg A(6) into the support leg, and fix it with the pin(A) and plastic knob(B).

STEP 4

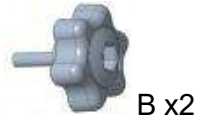

Note the
direction.

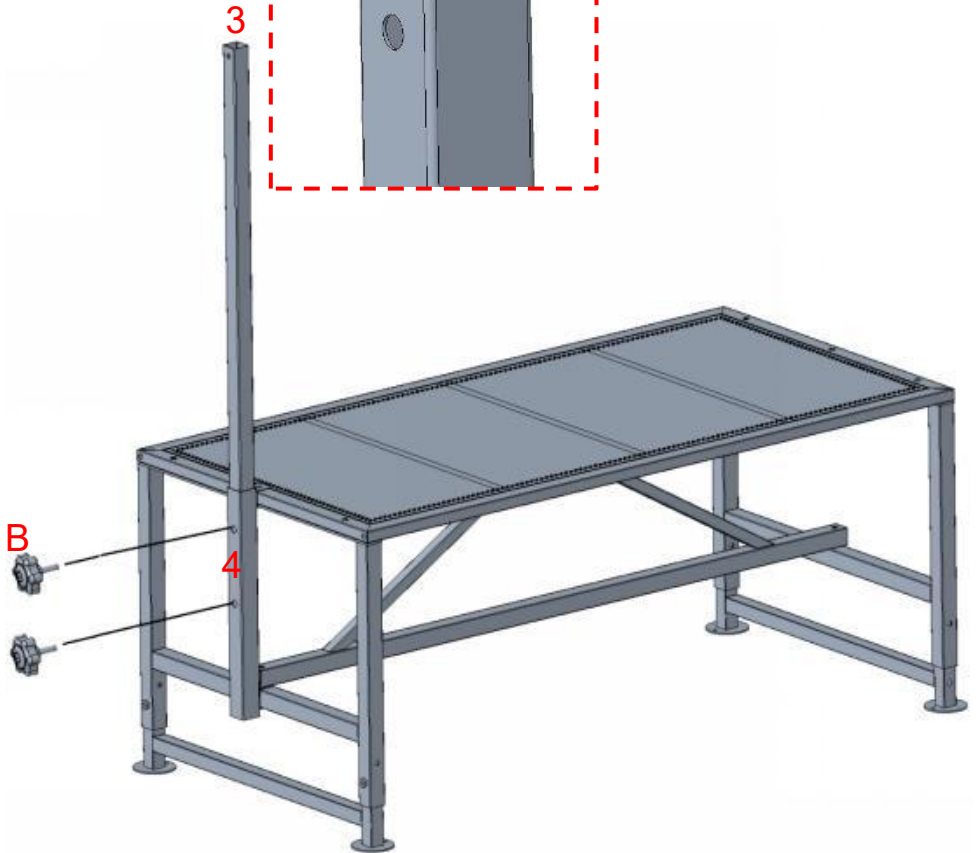

Insert the long pole(3) into the fixed tube(4) and secure it with the plastic knob(B).

Note:1.Insert the long pole according to the direction shown in the diagram.
2.The height of the whole goat head rack can be adjusted by loosening or tightening the plastic knob to move the long pole up and down.

STEP 5-1

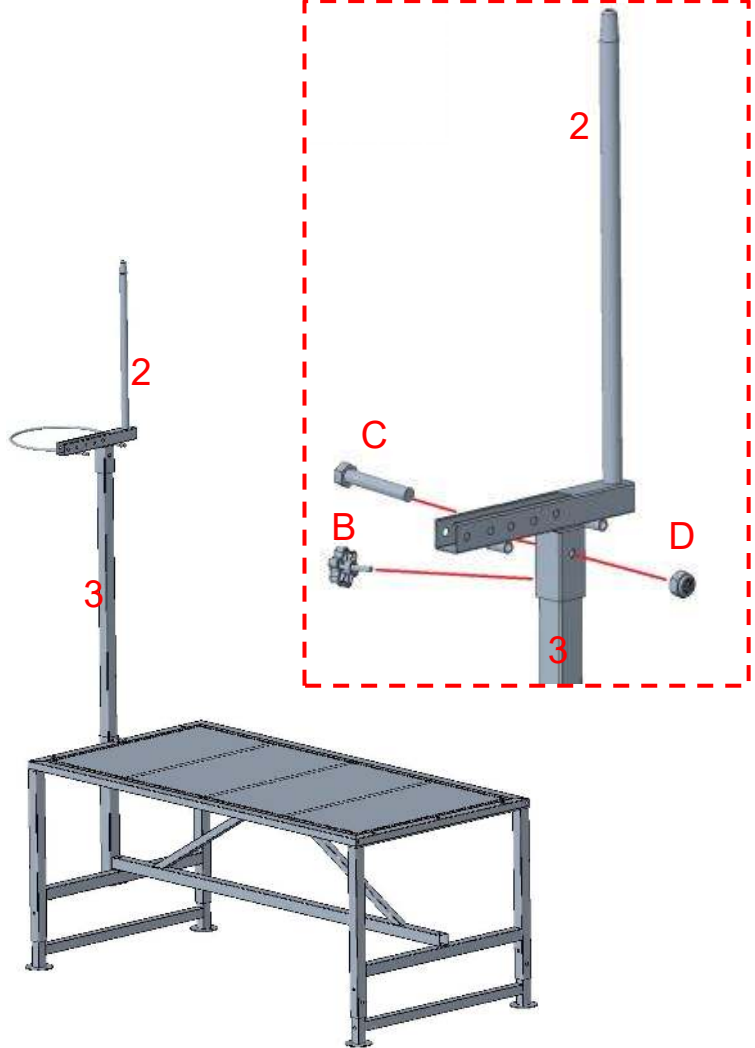

Secure the goat head(2) mounting bracket to the long pole(3) with screw(C) and plastic knob(B).

STEP 5-2



1 x1



A x1



movable rack

Insert the (1) into the goat head(2) mounting bracket and secure it with a pin(A).

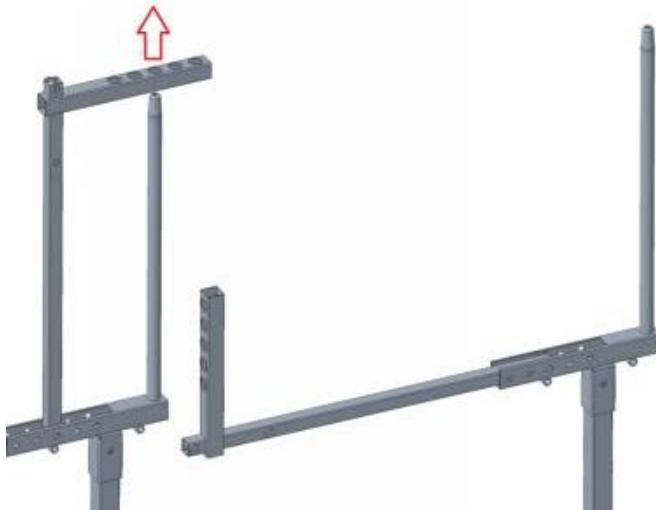

Lift the movable rack crossbar, align it with the round tube of the fixed rack, then lower it into place.

STEP 6

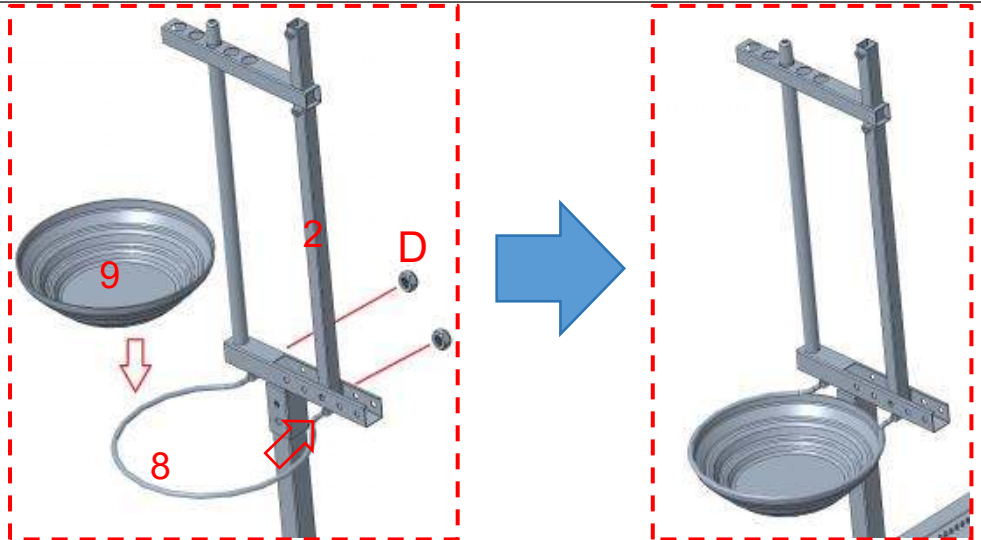
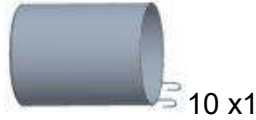

1. Insert the circular hoop(8) through the goat head(2) mounting bracket and tighten it with screws(D).

2. Place the basin(9) on the circular hoop for holding water or fodder.

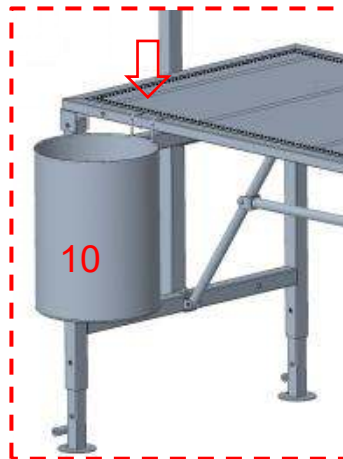

3. Hang the tool bag(10) on the platform. The platform is equipped with 4 positions for flexible adjustment according to usage habits.

STEP 7

M8*70mm



F x4



D x4



14 x1



15 x1

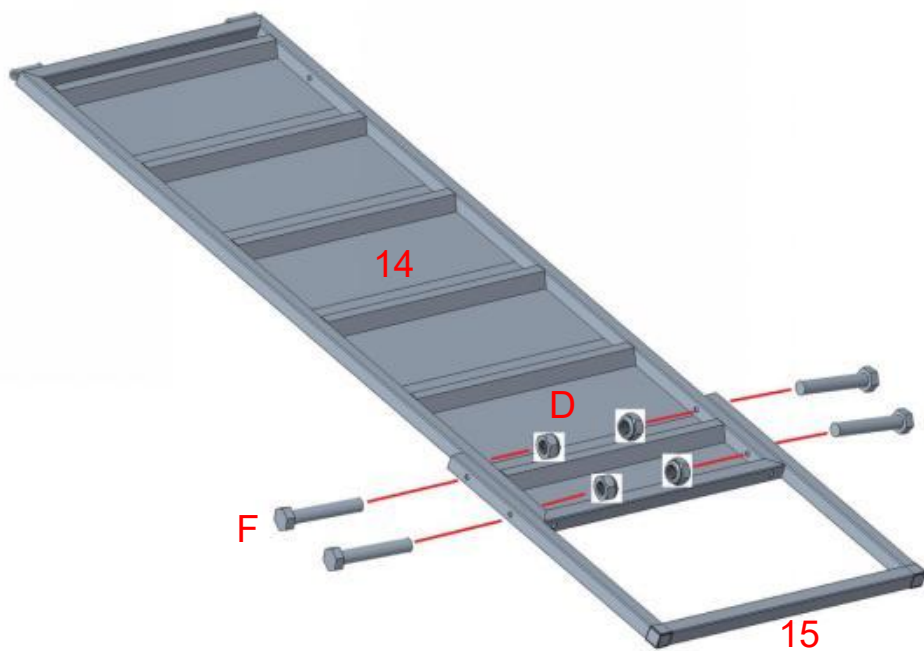

Secure the U-shaped pole(15) to the ramp(14) with screws(F).

STEP 8

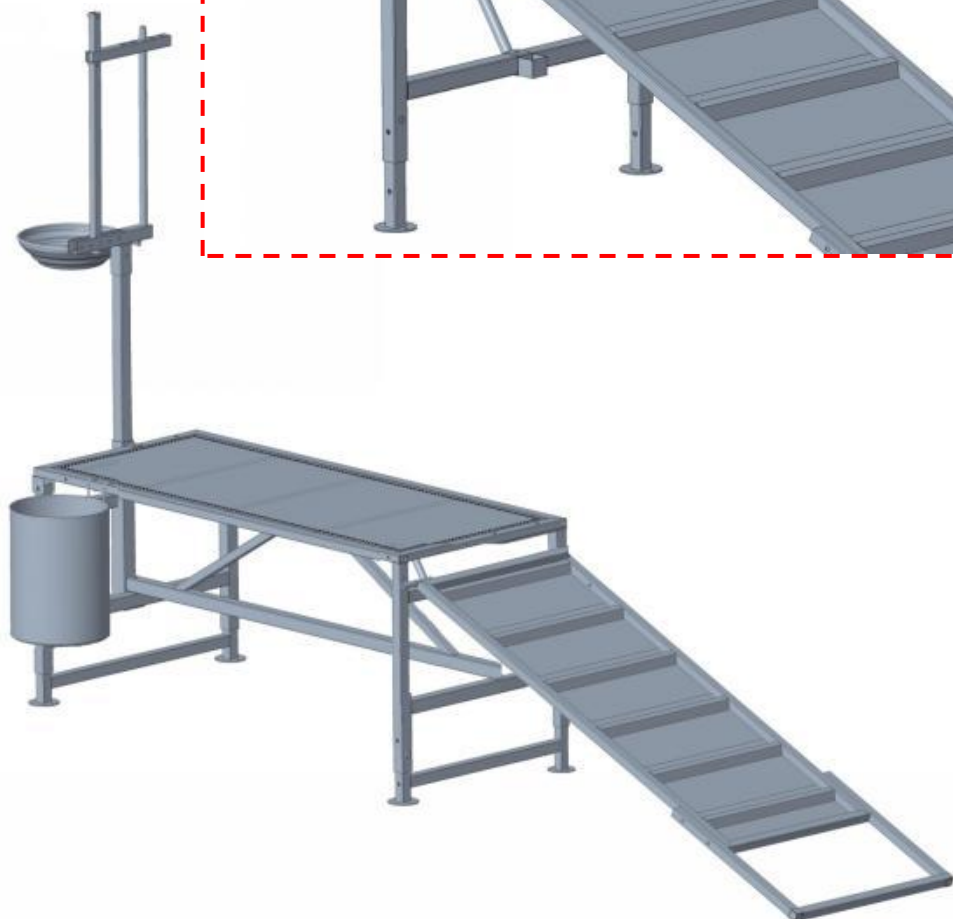
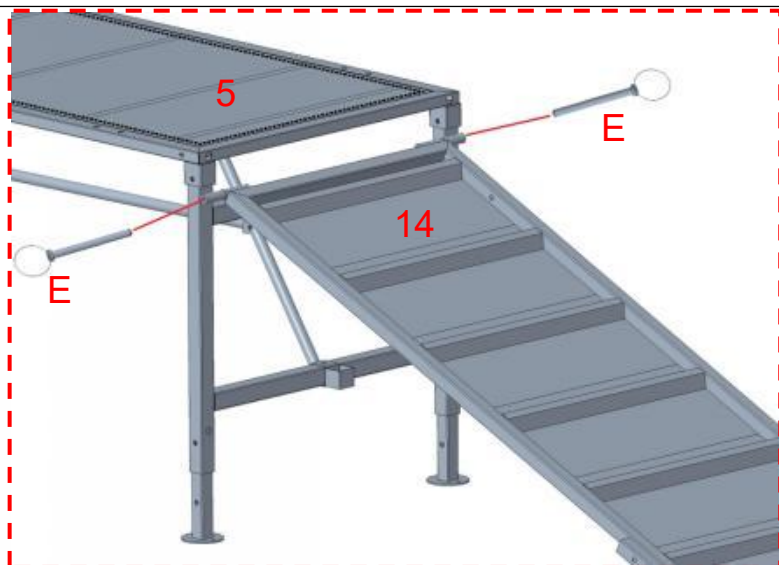

Secure the ramp(14) to the tabletop(5) with pins(E).

Headband Width Adjustment Instructions:



1. The fixed rack and movable rack are both equipped with 5 adjustment positions. The smaller the number, the narrower the spacing.
2. The upper and lower positions must be aligned to maintain a vertical state.
3. If you are unsure which position to choose, start with the middle position. If the goat's neck cannot be securely fixed, use a position with a smaller spacing.

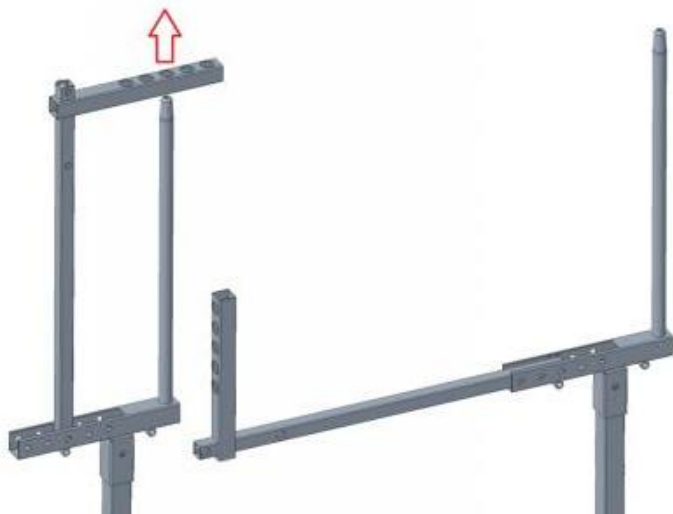

Lift the movable rack crossbar, align it with the round tube of the fixed rack, then lower it into place.



Open the bracket and guide the goat to the fixed rack.

Note: Adjust the height of the fixed rack so that the goat's lower neck is level with the lower crossbar of the bracket. This position allows the goat to lower its head to drink or feed, and it will not touch the upper crossbar to cause dislodgement when raising its head.



Lift the movable rack crossbar, align it with the round tube of the fixed rack, then lower it into place.

PRODUCT PARAMETER

Model	51*23inch-B
Safe Loading Weight	600lbs/272kg
Colour	Black
Desktop Size	51*23in(1295*584mm)

Manufacturer: Shanghai Sishun Technology Co., Ltd
Address: 4th Floor, Building 2, No. 599 Wan Zhen Road, Zhenxin Xincun Subdistrict, Jiading District, Shanghai, 201800 China
E-mail: support@vevor.com

Imported to AUS: SIHAO PTY LTD. 1 ROKEVA STREET EASTWOOD NSW 2122 Australia

Imported to USA: Sarven Technology Ltd. Suite 250, 9166 Anaheim Place, Rancho Cucamonga, CA 91730

VEVOR SUPER TOOLS LIMITED

EC REP

Address: Office 403, NESTA Business Centre, 4-5 Burton Hall Rd, Sandyford, Dublin 18, D18 A094, Ireland

Email: service-eu@vevor.com Tel: +353874373999

VEVOR TOOL HUB LIMITED

UK REP

Address: 2 Goldstone Close, Brighton and Hove, BN3 7PD, United Kingdom

Email: service-uk@vevor.com Tel: +447795204660



VEVOR

Upgrade · The Home Creator Way

Puesto de ganado

Modelo : 51*23 pulgadas-B

Modelo : 51*23 pulgadas-B

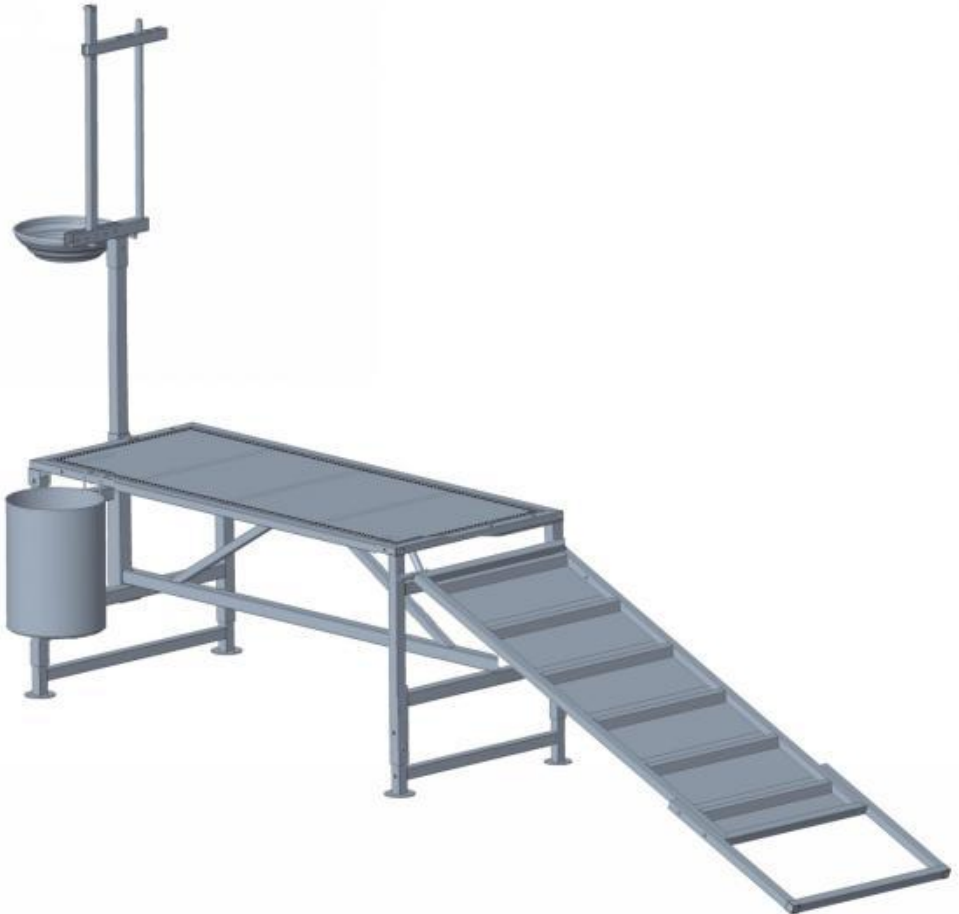

Estas son las instrucciones originales. Lea atentamente todo el manual antes de usar el producto. VEVOR se reserva el derecho de interpretar el manual de usuario. El aspecto del producto puede variar con respecto al que reciba. Le pedimos disculpas si no le informamos nuevamente sobre actualizaciones de tecnología o software.

SAFETY INSTRUCTIONS

ADVERTENCIA:

Lea este material antes de usar este producto. No hacerlo puede provocar lesiones graves.

Precauciones de montaje

13. Ensámblelo únicamente siguiendo estas instrucciones. Un montaje incorrecto puede generar riesgos.
14. Durante el montaje, utilice gafas de seguridad homologadas por ANSI y guantes de trabajo resistentes.
15. Mantenga la zona de montaje limpia y bien iluminada.
16. Mantenga a los curiosos alejados de la zona durante la concentración.
17. No participe en la reunión si está cansado o bajo los efectos del alcohol, las drogas o los medicamentos.
18. Las funcionalidades del producto se aplican únicamente a productos ensamblados de forma correcta y completa.
19. Ensámblelo sobre una superficie plana, nivelada, dura y lisa, capaz de soportar de forma segura el soporte para ganado.
20. Para obtener información adicional sobre las piezas que se enumeran en las páginas siguientes, consulte el diagrama de montaje de este manual. Desempaque y separe todas las piezas en un área de trabajo limpia.
21. El producto cumple con las normas y regulaciones pertinentes. La instalación de este dispositivo debe cumplir con todas las normativas aplicables y solo debe utilizarse en áreas bien ventiladas. Lea el manual de usuario antes de instalar y utilizar este equipo.
22. Este aparato no está diseñado para ser utilizado por personas (incluidos niños) con capacidades físicas, sensoriales o mentales reducidas, o con falta de experiencia y conocimiento, a menos que una persona responsable de su seguridad les haya supervisado o instruido sobre el uso del aparato.
23. Este aparato está diseñado para ser utilizado en aplicaciones domésticas y similares, tales como:

- casas de campo;









24. Por favor, conserve el producto adecuadamente. Compruebe si el producto presenta alguna anomalía antes de usarlo. Si presenta alguna anomalía, deje de usarlo.





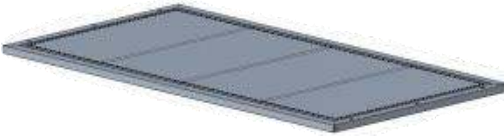





Tome precauciones

6. NO SE SIENTE NI SE PARE SOBRE ESTE ARTÍCULO.
7. Este producto no es un juguete. No permita que los niños jueguen con este artículo ni cerca de él.
8. No exceda lo especificado capacidades de peso.
9. Utilizar únicamente según lo previsto.
10. Inspeccione el producto antes de cada uso; no lo utilice si alguna pieza está suelta o dañada.

GUARDE ESTE MANUAL

PARTS LIST

No.	Parte	Nombre	Cantidad
1		Estante móvil	1
2		Estante fijo	1
3		Palo largo	1
4		Varilla fija	1
5		Superficie de la mesa	1
6		Pierna ajustable A	2
7		Pierna ajustable B	1
7-1		Pierna ajustable B	1
8		aro circular	1

9		Cuenca	1
No.	Parte	Nombre	Cantidad
10		Bolsa de herramientas	1
11		Biela	1
12		Rampa	1
13		poste en forma de U	1
A		Pasador de liberación rápida	5
B		pomo de plástico	7
do		Tornillo M8*45 mm	8
D		Tuerca M8	16
mi		Pasador de liberación rápida	2
F		Tornillo M8*60 mm	4

GRAM O		Tornillo M8*80 mm	2
-----------	--	----------------------	---

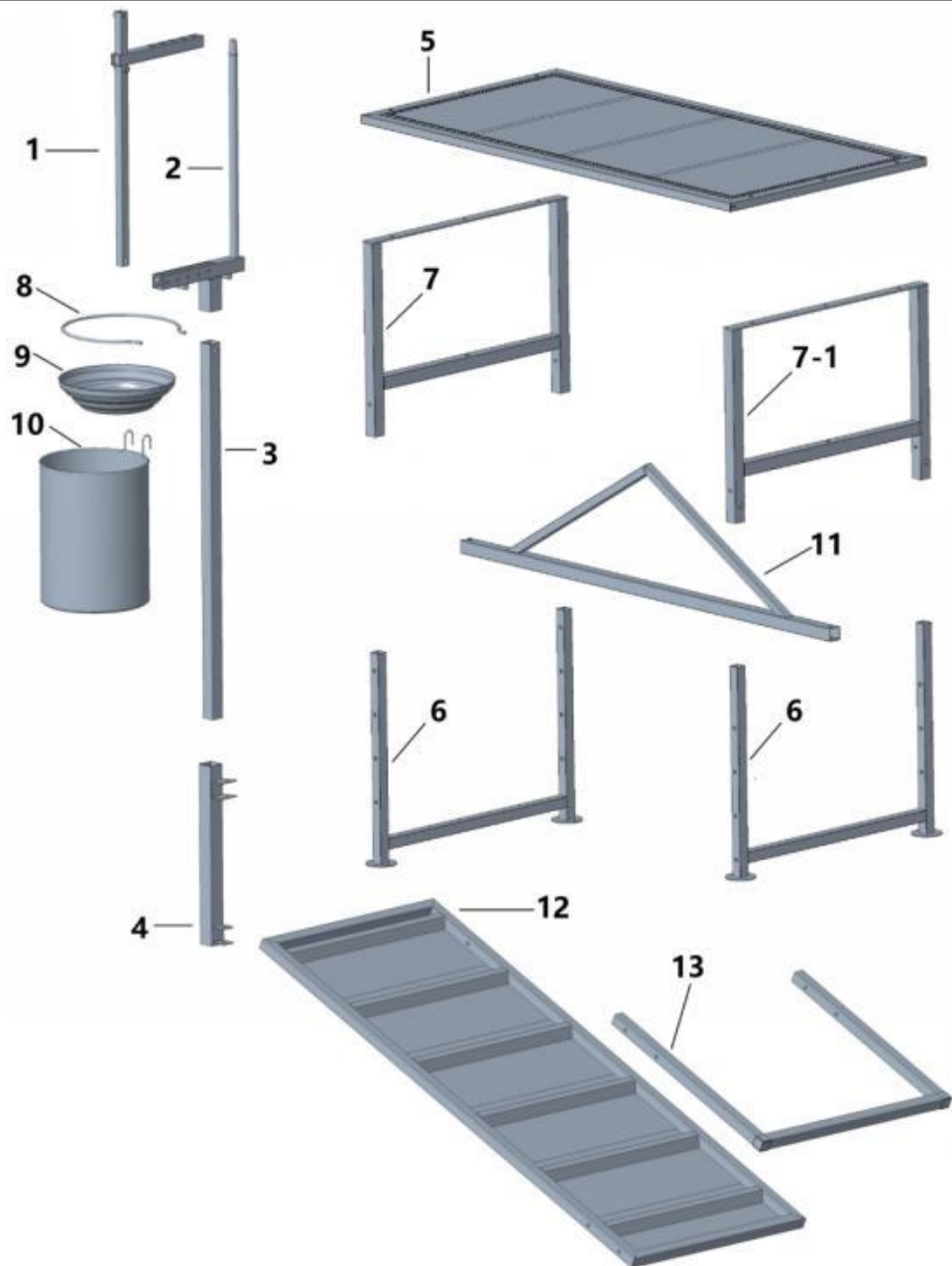

ASSEMBLY STEP

PASO 1



5 x1



7 x1



7-1 x1 M8*35mm



C x5



D x5

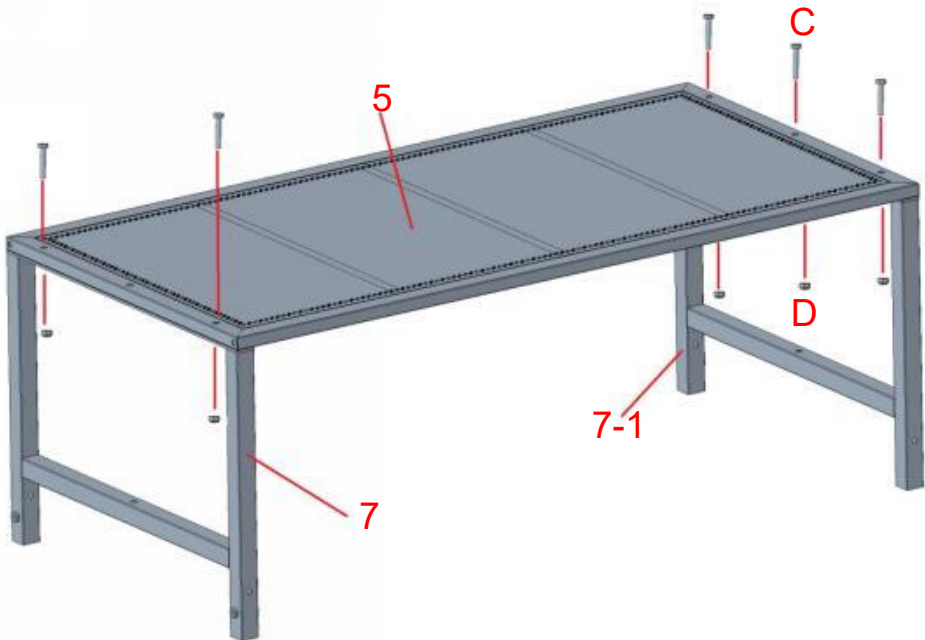

Fije la pata ajustable B (7) a la superficie de la mesa (5) con tornillos (C) .

PASO 2



4 x 1



11 X 1

M8*35mm



C x2



D x4 M8*70mm



F x2

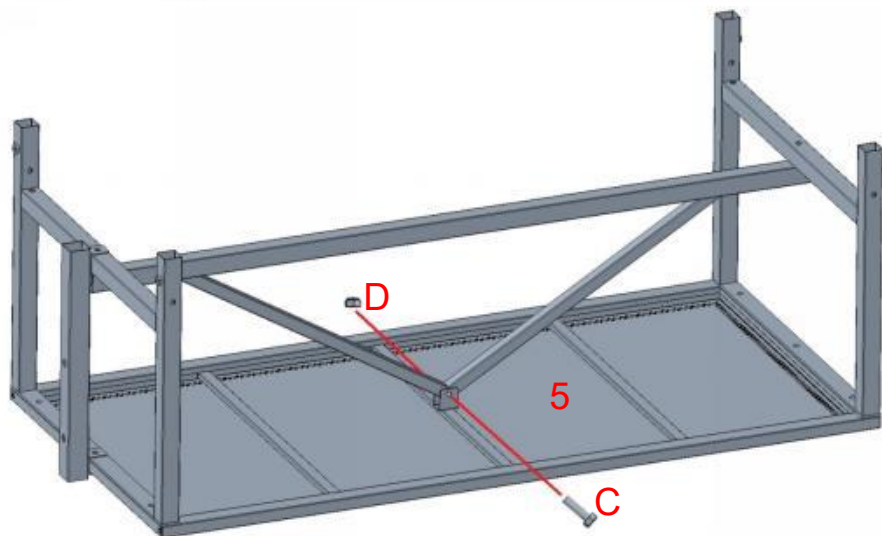
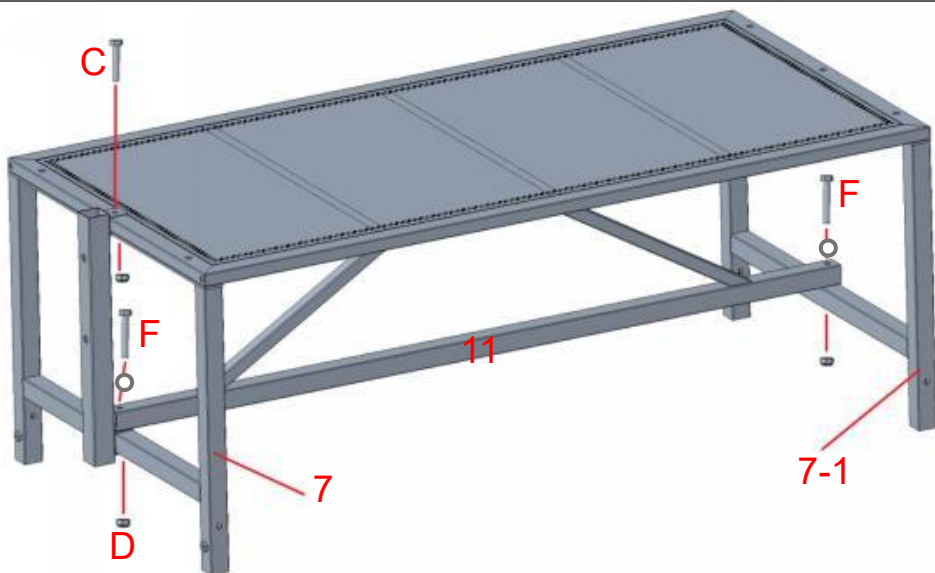

Asegure la varilla fija (4) y la biela (11) a la mesa (5) con tornillos (C y H) .

PASO 3

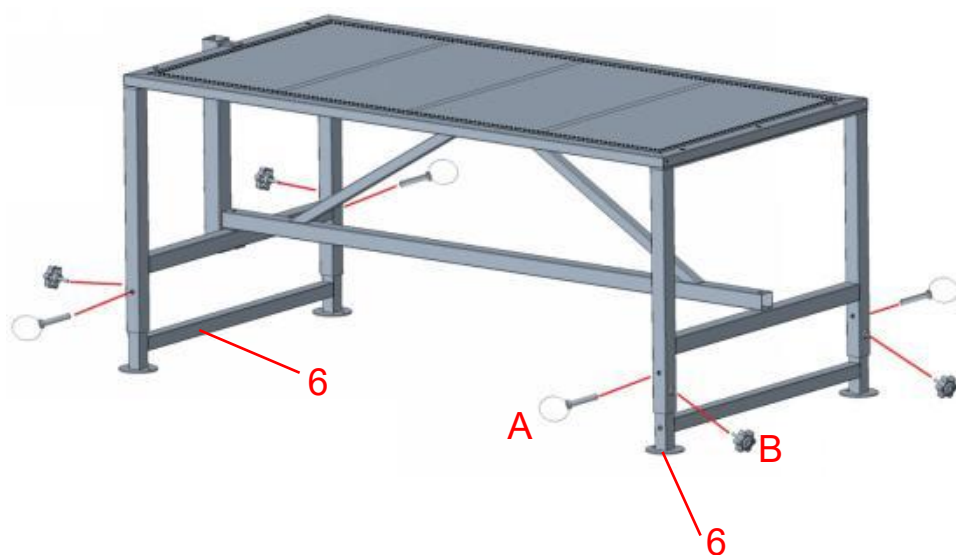
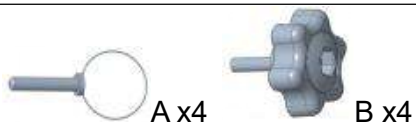

Inserte la pata ajustable A (6) en la pata de soporte y fíjela con el pasador (A) y la perilla de plástico (B) .

PASO 4

3 x1



B x2

Note the
direction.



3

B

4

Inserte el poste largo (3) en el tubo fijo (4) y fíjelo con la perilla de plástico (B) .

Nota: 1. Inserte el poste largo según la dirección que se muestra en el diagrama.

2. La altura del soporte para cabezas de cabra se puede ajustar aflojando o apretando la perilla de plástico para mover el poste largo hacia arriba y

hacia abajo.

PASO

5-1

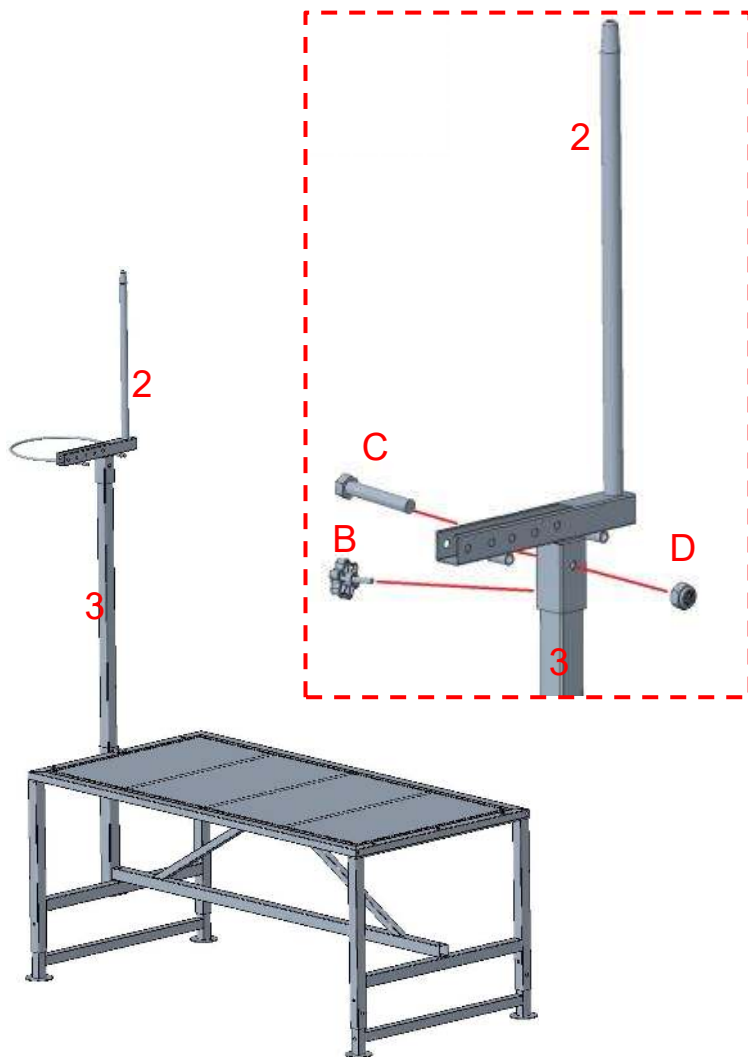

Fije el soporte de montaje de la cabeza de cabra (2) al poste largo (3) con el tornillo (C) y la perilla de plástico (B) .

PASO

5-2

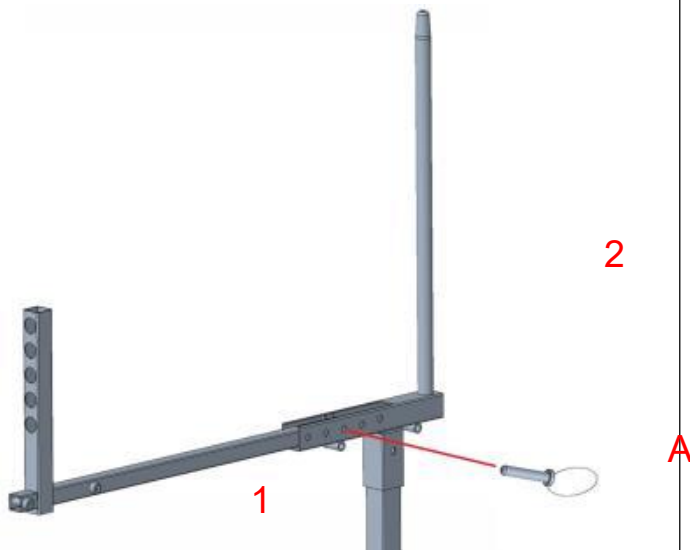

movable rack

Inserte el (1) en el soporte de montaje de cabeza de cabra (2) y fijelo con un pasador (A) .

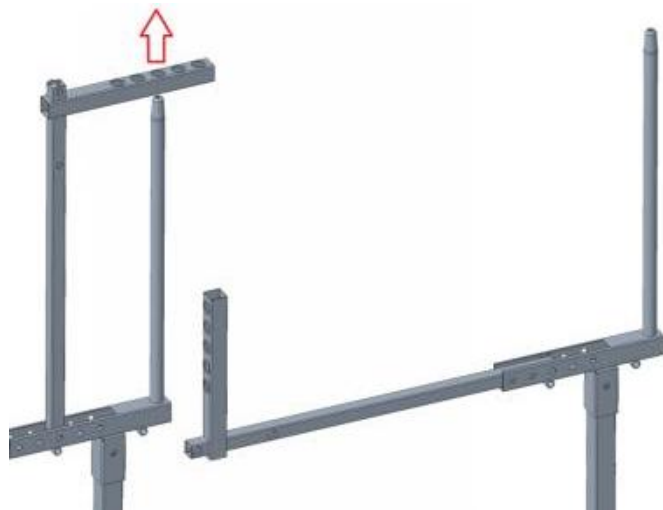

Levante la barra transversal móvil del bastidor , alinéela con el tubo redondo del bastidor fijo y, a continuación, bájela hasta colocarla en su sitio.

PASO 6

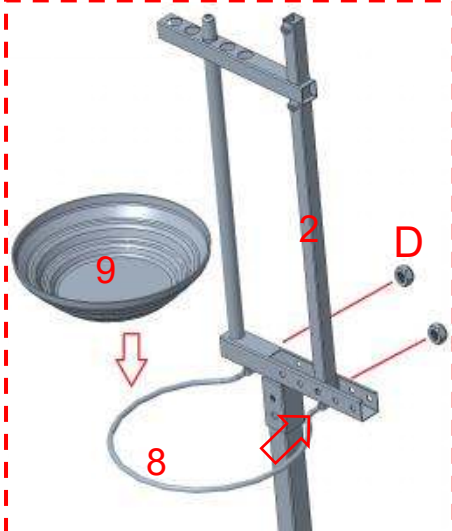
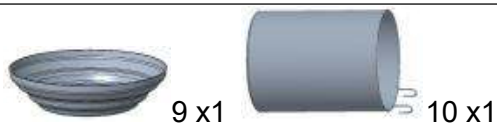

1. Inserte el aro circular (8) a través del soporte de montaje de la cabeza de cabra (2) y apriételo con los tornillos (D) .
2. Coloque el recipiente (9) sobre el aro circular para contener agua o forraje.

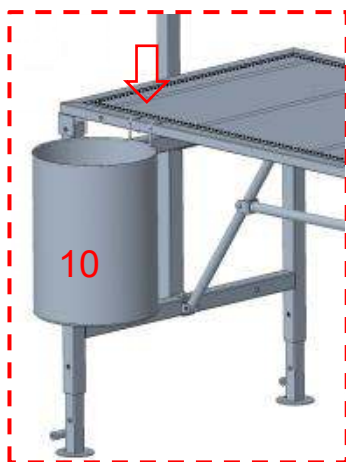

3. Cuelgue la bolsa de herramientas (10) en la plataforma. La plataforma está equipada con 4 posiciones para un ajuste flexible según los hábitos de uso.

PASO 7

M8*70mm



F x4



D x4



14 x 1



15 x 1

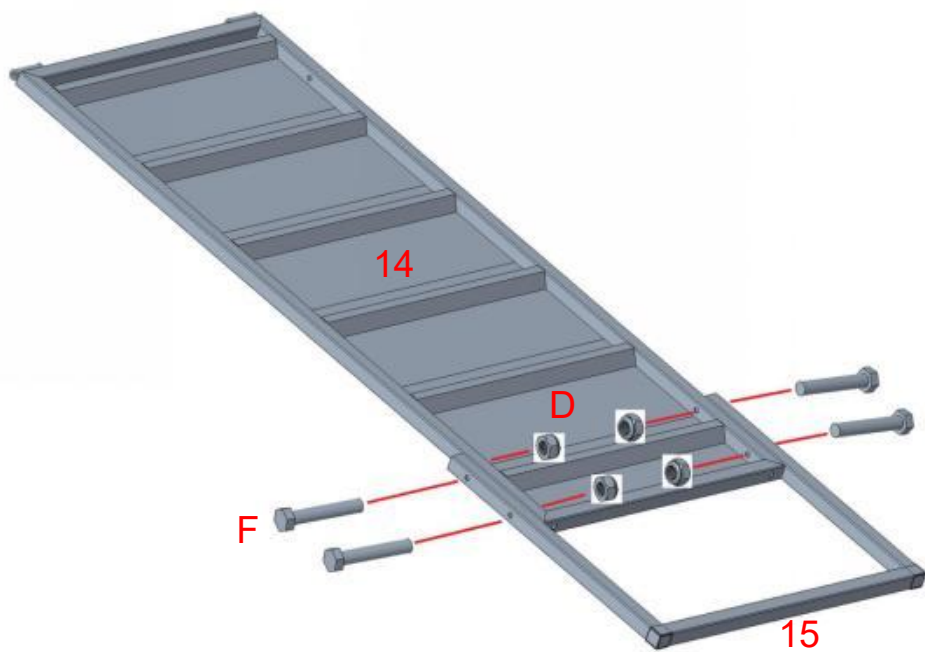

Fije el poste en forma de U (15) a la rampa (14) con tornillos (F) .

PASO 8

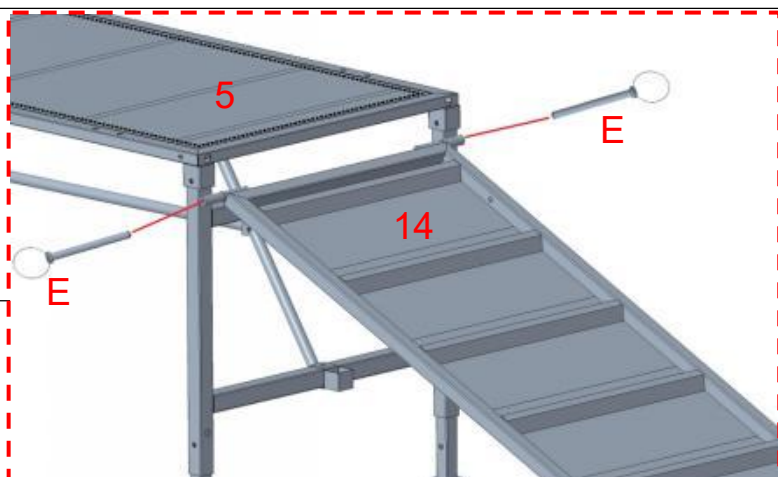

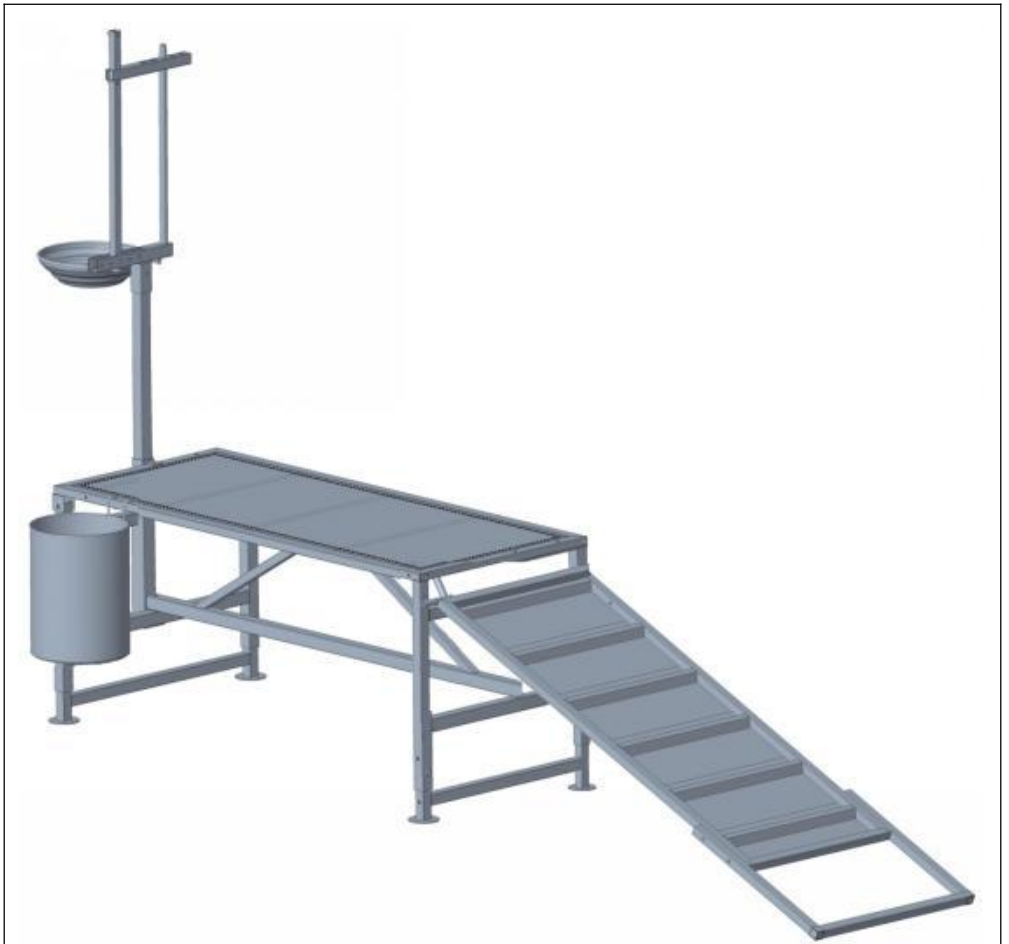

Asegurar el rampa (14) a la superficie de la mesa (5) con pasadores (E) .

Instrucciones para ajustar el ancho de la diadema:



4. The fixed rack and movable rack are both equipped with 5 adjustment positions. The smaller the number, the narrower the spacing.
5. The upper and lower positions must be aligned to maintain a vertical state.
6. If you are unsure which position to choose, start with the middle position. If the goat's neck cannot be securely fixed, use a position with a smaller spacing.

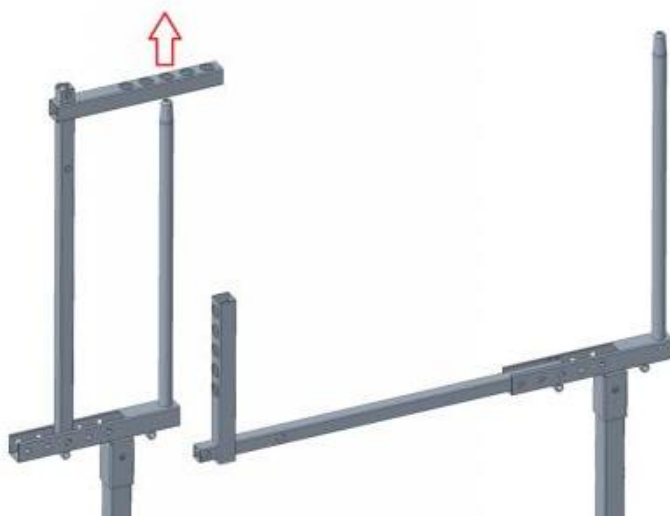

Levante la barra transversal móvil del bastidor , alinéela con el tubo redondo del bastidor fijo y , a continuación , bájela hasta colocarla en su sitio.

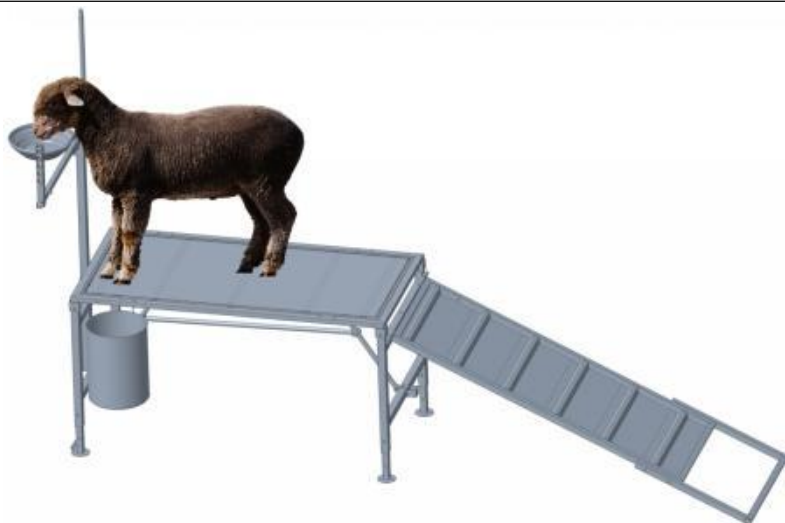

Abra el soporte y guíe a la cabra hacia el estante fijo .

Nota: Ajuste la altura del soporte fijo de manera que la parte inferior del cuello de la cabra quede a la altura del travesaño inferior del soporte. Esta posición permite que la cabra baje la cabeza para beber o comer, y evita que toque el travesaño superior y se desplace al levantarla.



Levante la barra transversal móvil del bastidor , alinéela con el tubo

redondo del bastidor fijo y, a continuación, bájela hasta colocarla en su sitio.

PRODUCT PARAMETER

Modelo	51*23 pulgadas-B
Peso de carga seguro	600 libras/272 kg
Color	Negro
Tamaño de escritorio	51*23 pulgadas (1295*584 mm)

Manufacturer: Shanghai Sishun Technology Co., Ltd
Address: 4th Floor, Building 2, No. 599 Wan Zhen Road, Zhenxin Xincun Subdistrict, Jiading District, Shanghai, 201800 China
E-mail: support@vevor.com

Imported to AUS: SIHAO PTY LTD. 1 ROKEVA STREET EASTWOOD NSW 2122 Australia

Imported to USA: Sarven Technology Ltd. Suite 250, 9166 Anaheim Place, Rancho Cucamonga, CA 91730

VEVOR SUPER TOOLS LIMITED

EC REP

Address: Office 403, NESTA Business Centre, 4-5 Burton Hall Rd, Sandyford, Dublin 18, D18 A094, Ireland

Email: service-eu@vevor.com Tel: +353874373999

VEVOR TOOL HUB LIMITED

UK REP

Address: 2 Goldstone Close, Brighton and Hove, BN3 7PD, United Kingdom

Email: service-uk@vevor.com Tel: +447795204660



VEVOR

Upgrade · The Home Creator Way

Boskapsstånd

Modell : 51*23 tum-B

Modell : 51*23 tum-B

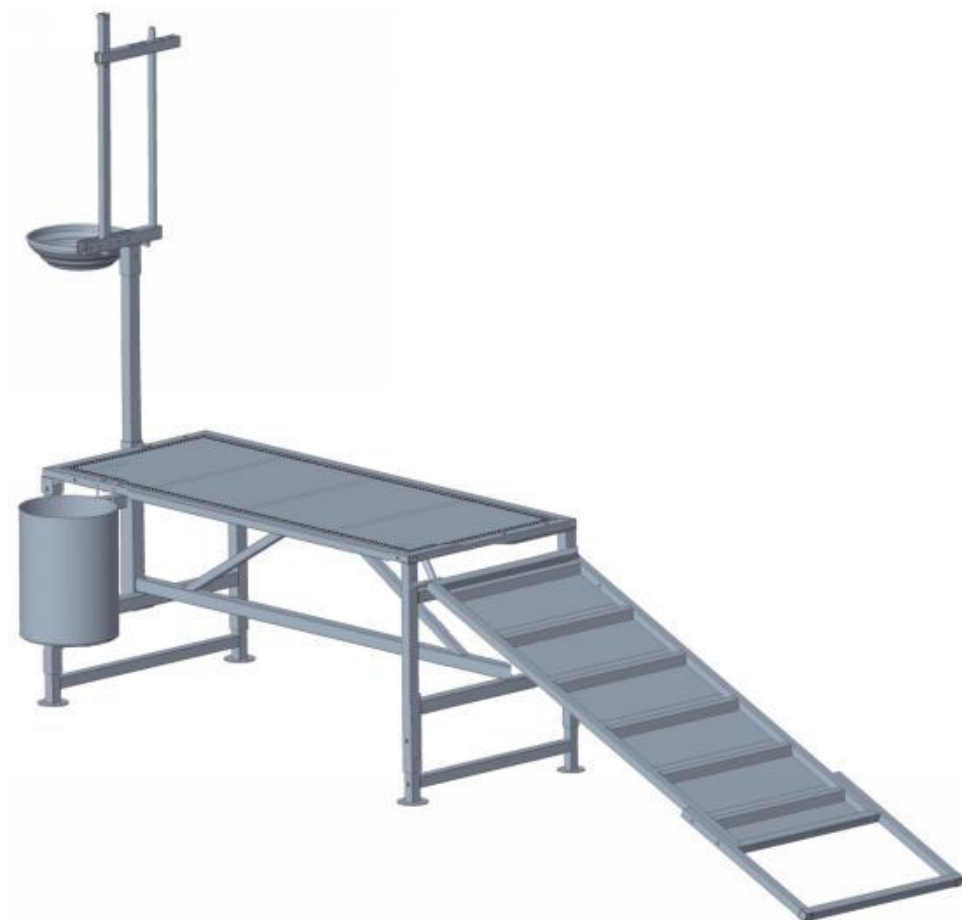

Detta är originalinstruktionerna, vänligen läs alla instruktioner noggrant innan du använder produkten. VEVOR förbehåller sig en tydlig tolkning av vår användarmanual. Produktens utseende ska vara beroende av den produkt du mottagit. Vi ber om ursäkt för att vi inte kommer att informera dig igen om det finns några teknik- eller programuppdateringar för vår

produkt.

SAFETY INSTRUCTIONS

WARNING:

Läs detta material innan du använder produkten. Underlåtenhet att göra det kan leda till allvarliga skador.

Monteringsförsiktighetsåtgärder

25. Montera endast enligt dessa instruktioner. Felaktig montering kan skapa risker.
26. Använd ANSI-godkända skyddsglasögon och kraftiga arbetshandskar under monteringen.
27. Håll samlingsområdet rent och väl upplyst.
28. Håll åskådare borta från området under monteringen.
29. Montera inte om du är trött eller påverkad av alkohol, droger eller mediciner.
30. Produktegenskaperna gäller endast korrekt och fullständigt monterade produkter.
31. Montera på en plan, jämn, hård och slät yta som säkert kan bära upp boskapsstativet .
32. För ytterligare information om delarna som listas på följande sidor, se monterings schemat i denna manual. Packa upp och separera alla delar på en ren arbetsyta.
33. Produkten uppfyller relevanta standarder och föreskrifter. Installationen av denna enhet måste uppfylla alla tillämpliga föreskrifter och den bör endast användas i välventilerade utrymmen. Läs användarmanualen innan du installerar och använder denna utrustning.
34. Denna apparat är inte avsedd att användas av personer (inklusive barn) med nedsatt fysisk, sensorisk eller mental förmåga, eller bristande erfarenhet och kunskap, såvida de inte har övervakats eller fått instruktioner om användningen av apparaten av en person som ansvarar för deras säkerhet.
35. Denna apparat är avsedd att användas i hushåll och liknande

tillämpningar, såsom:

- bondgårdar;







36. Förvara produkten ordentligt. Kontrollera om produkten är avvikande före användning. Om den är avvikande, sluta använda den.











Använd försiktighetsåtgärder

11. SITTA ELLER STÅ INTE PÅ DENNA FÖRENING.
12. Denna produkt är inte en leksak. Låt inte barn leka med eller i närheten av denna produkt.
13. Överskrid inte angivna viktkapacitet.
14. Använd endast som avsett.
15. Kontrollera före varje användning; använd inte om delar är lösa eller skadade.

SPARA DENNA HANDBOK

PARTS LIST

Inga .	Del	Namn	Anta l
1		Flyttbart ställ	1
2		Fast rack	1
3		Lång stång	1
4		Fast stång	1
5		Bordsskiva	1
6		Justerbart ben A	2
7		Justerbart ben B	1
7-1		Justerbart ben B	1
8		Rund båge	1

9		Handfat	1
Inga	Del	Namn	Antal
10		Verktygsväska	1
11		Vevstake	1
12		Ramp	1
13		U-formad stolpe	1
En		Snabbkopplingsstift	5
B		Plastknopp	7
C		Skruva M8*45mm	8
D		Mutter M8	16
E		Snabbkopplingsstift	2
F		Skruva M8*60mm	4

G		Skruva M8*80mm	2
---	--	-------------------	---

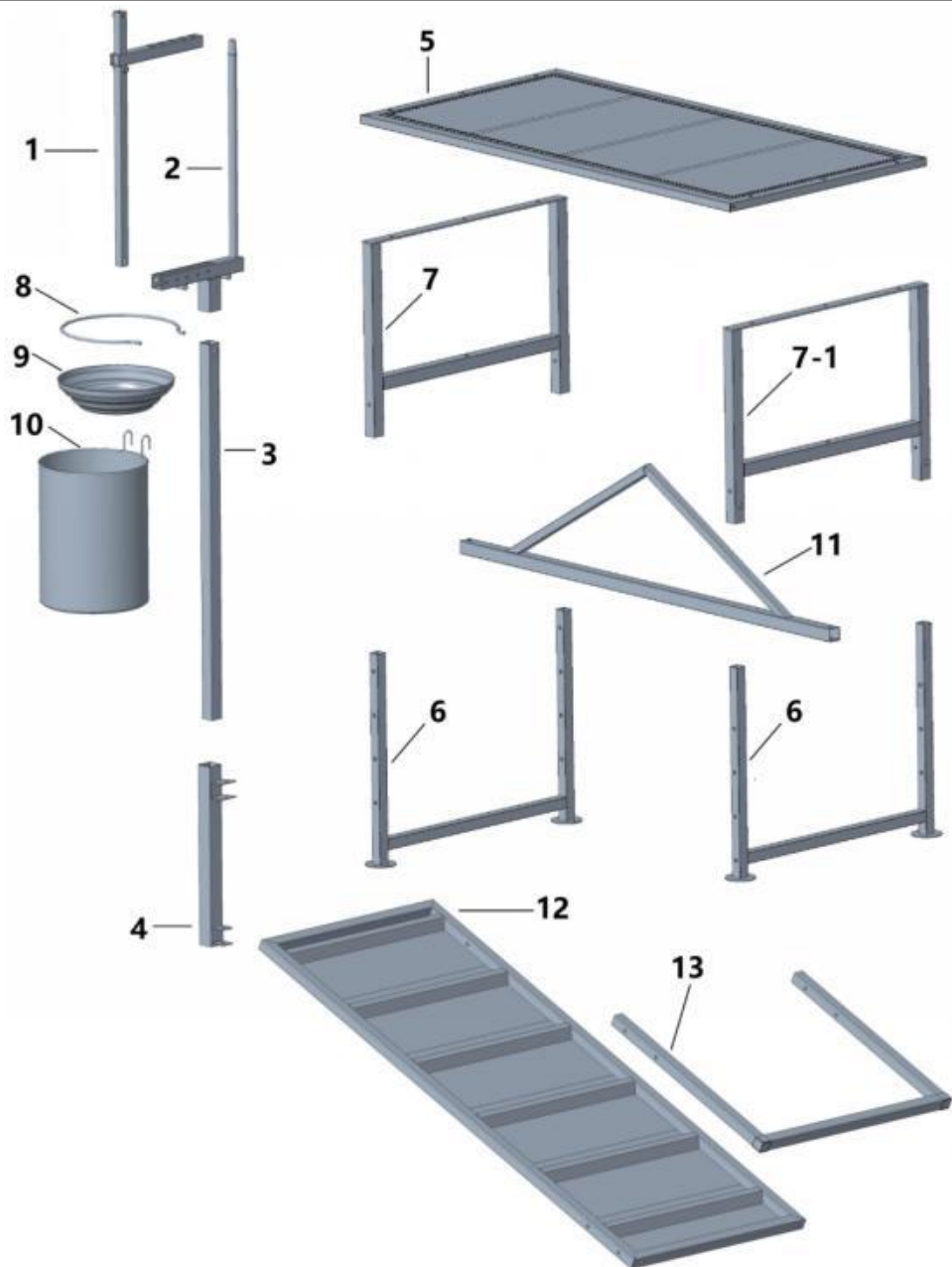

ASSEMBLY STEP

STEG 1



5x1



7 x 1



7-1 x 1 M8*35mm



C x 5



D x 5

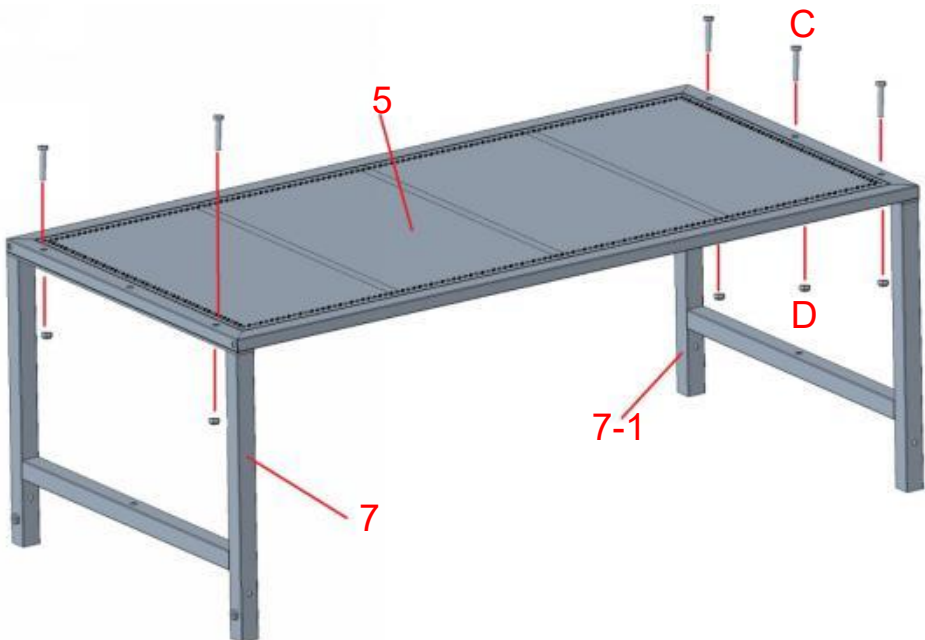

Fäst det justerbara benet B (7) på bordsskivan (5) med skruvar (C) .

STEG 2



4x1



11X1

M8*35mm



C x2



D x4 M8*70mm



F x2

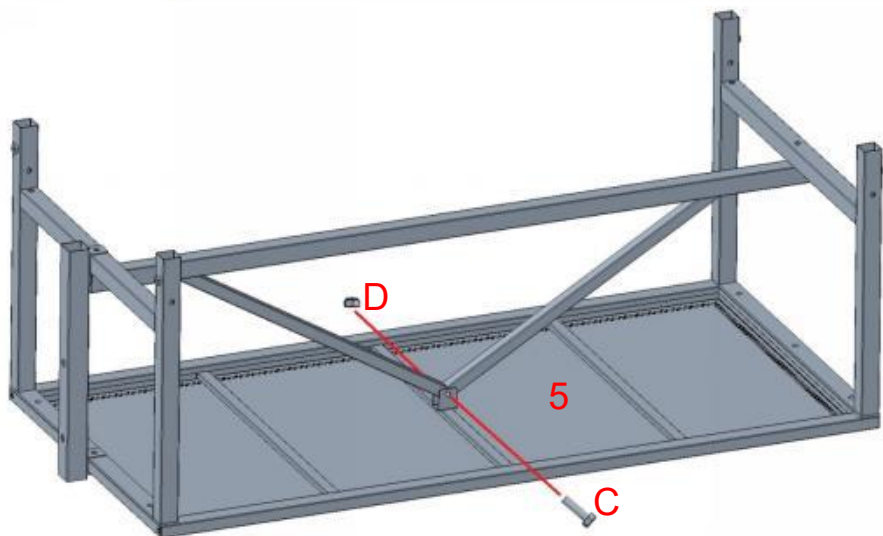
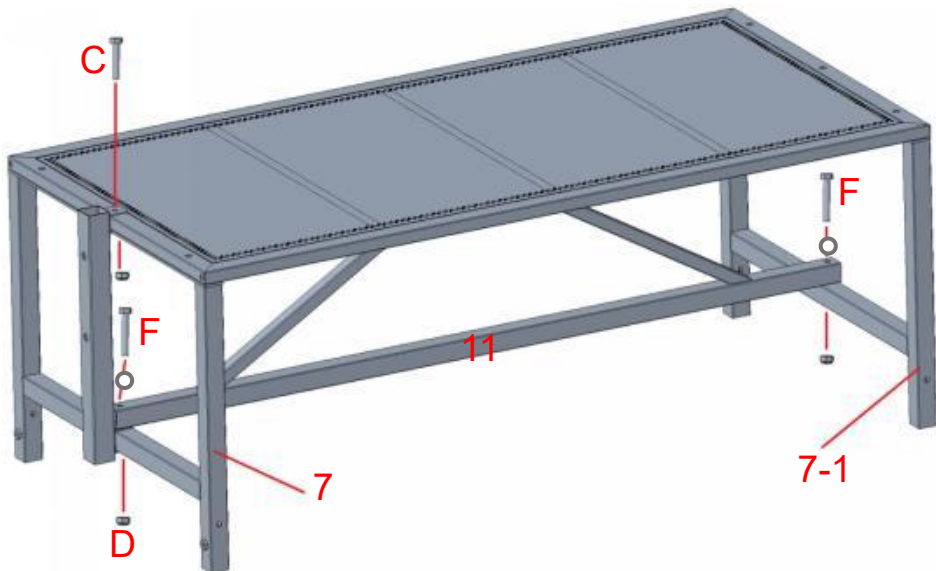

Fäst den fasta stängan (4) och vevstängan (11) till bordsskivan (5) med skruvar (C och H) .

STEG 3

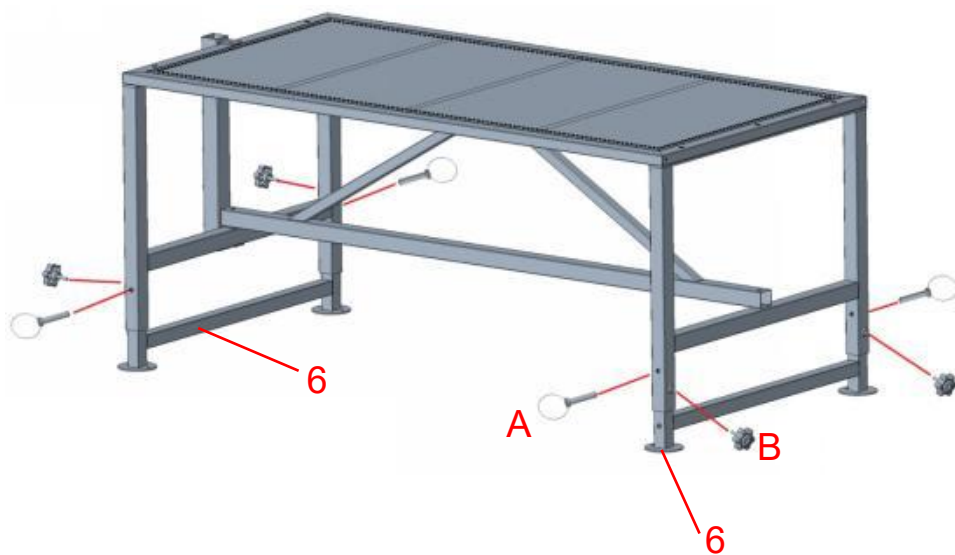
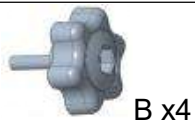

Sätt i det justerbara benet A (6) i stödbenet och fixera det med stiftet (A) och plastknoppen (B) .

STEG 4

3 x 1

B x 2

Note the
direction.

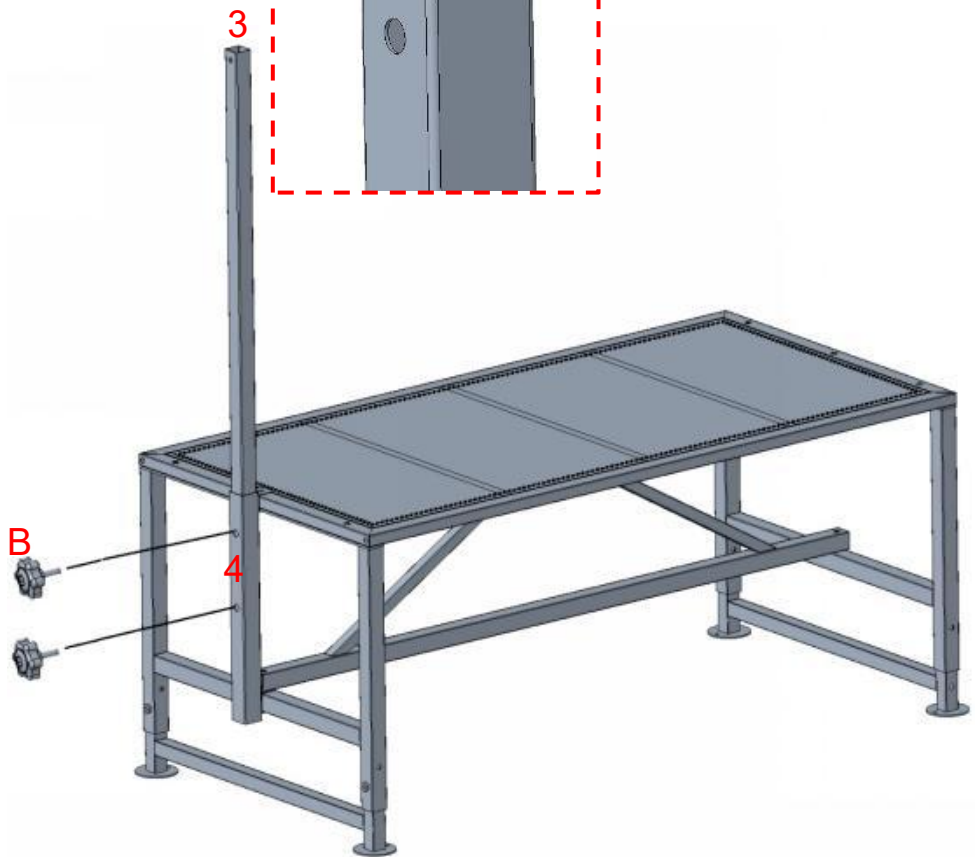

Sätt in den långa stången (3) i det fasta röret (4) och fäst den med plastknoppen (B) .

Obs: 1. Sätt i den långa stången enligt riktningen som visas i diagrammet.
2. Höjden på hela gethuvudstället kan justeras genom att lossa eller dra åt plastvredet för att flytta den långa stången upp och ner.

STEG 5-1

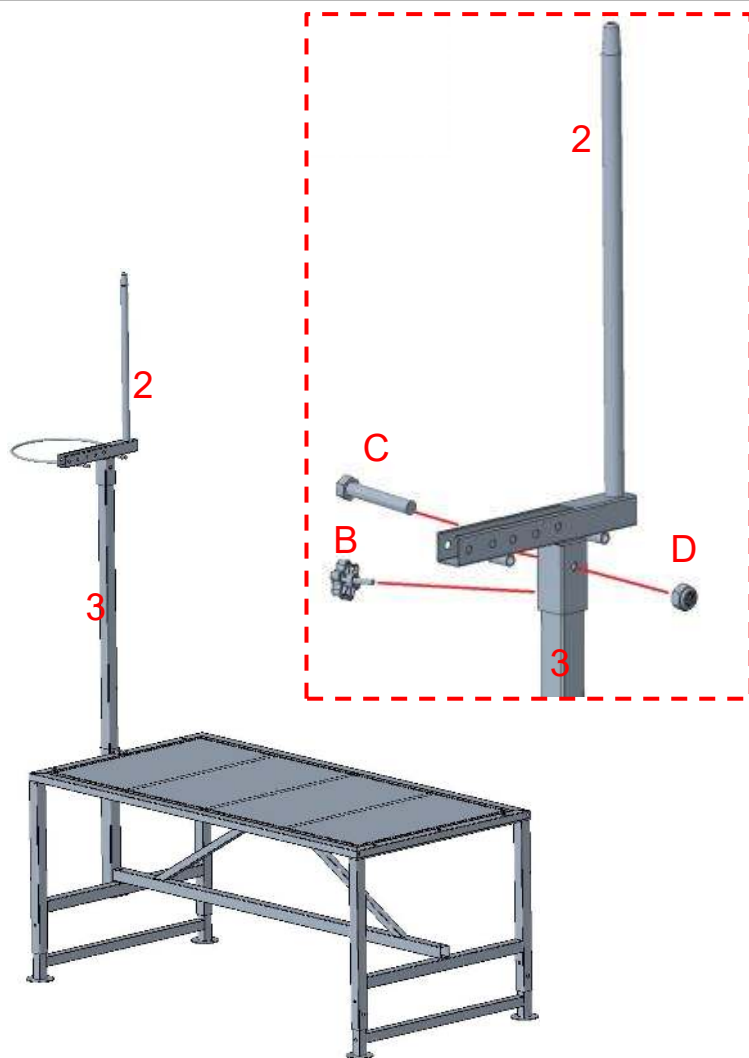
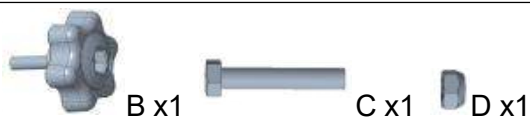

Fäst gethuvudets (2) monteringsfäste på den långa stängen (3) med skruv (C) och plastknopp (B) .

STEG 5-2



1 x1



A x1

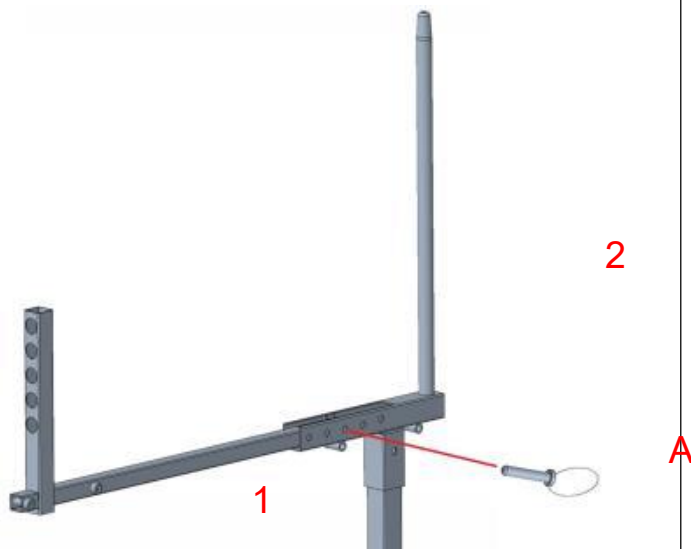

movable rack

Sätt in (1) i gethuvudets (2) monteringsfäste och säkra det med en sprint (A) .

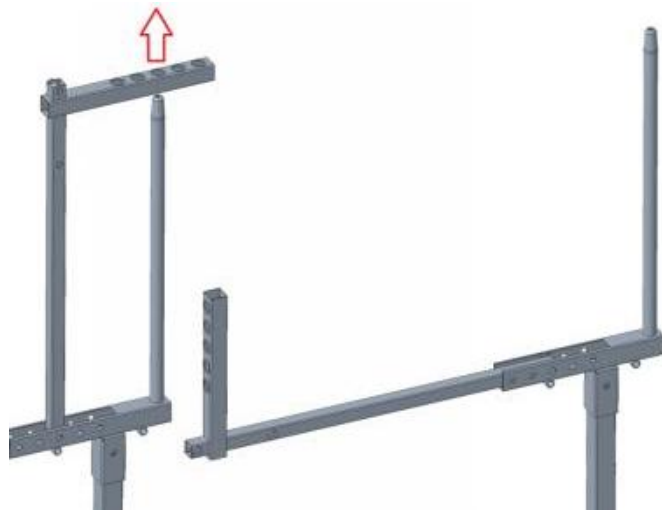

Lyft den rörliga tvärstången på gallret, rikta in den med det runda röret på det fasta gallret och sänk sedan ner det på plats.

STEG 6

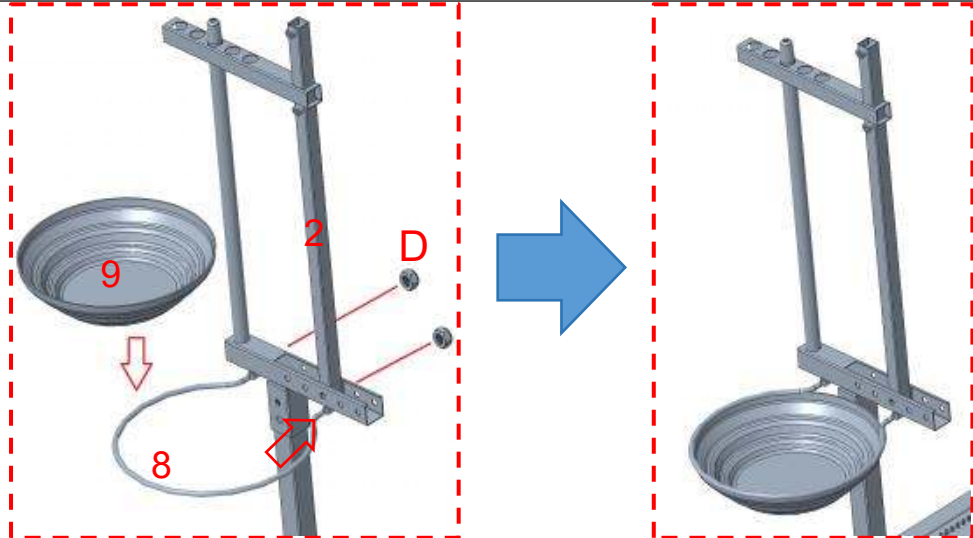

1. För in den runda bågen (8) genom gethuvudets (2) monteringsfästet och dra åt det med skruvar (D) .
2. Placera skålen (9) på den runda ringen för att förvara vatten eller foder.

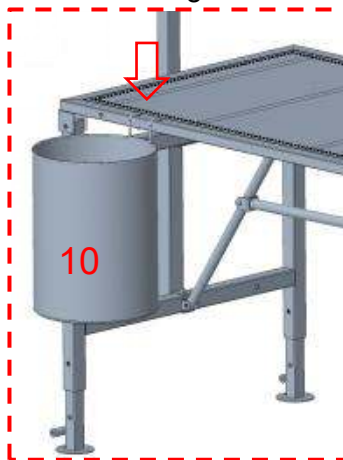

3. Häng verktygsväskan (10) på plattformen. Plattformen är utrustad med 4 lägen för flexibel justering efter användningsvanor.

STEG 7

M8*70mm

F x4 D x4



14x1



15x1

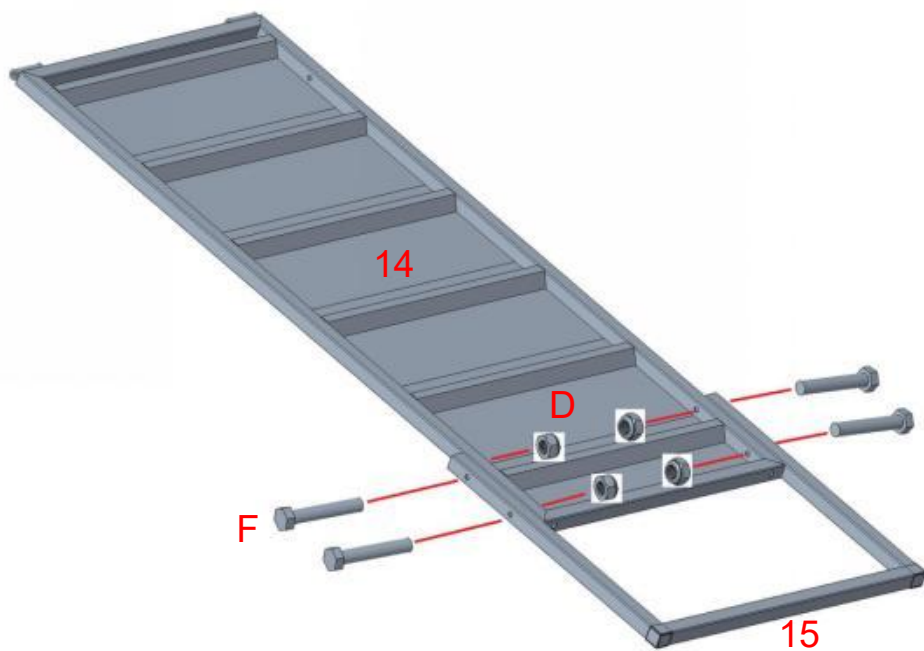

Fäst den U-formade stängen (15) på rampen (14) med skruvar (F) .

STEG 8

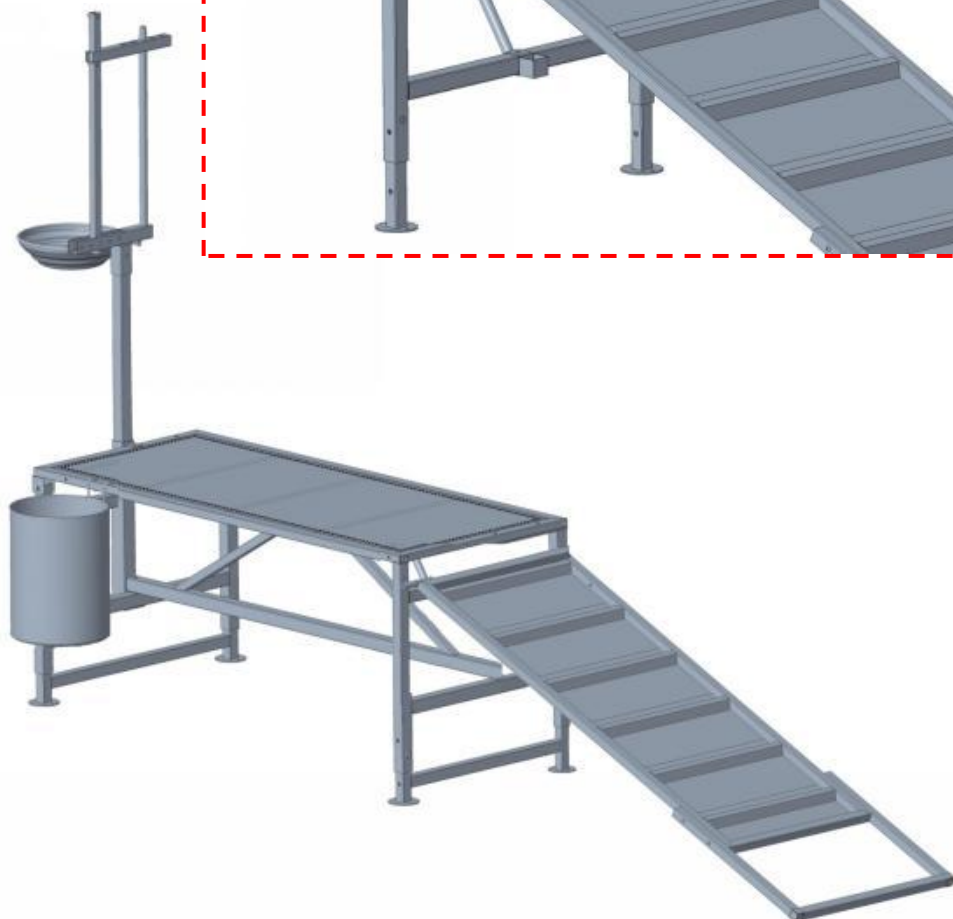
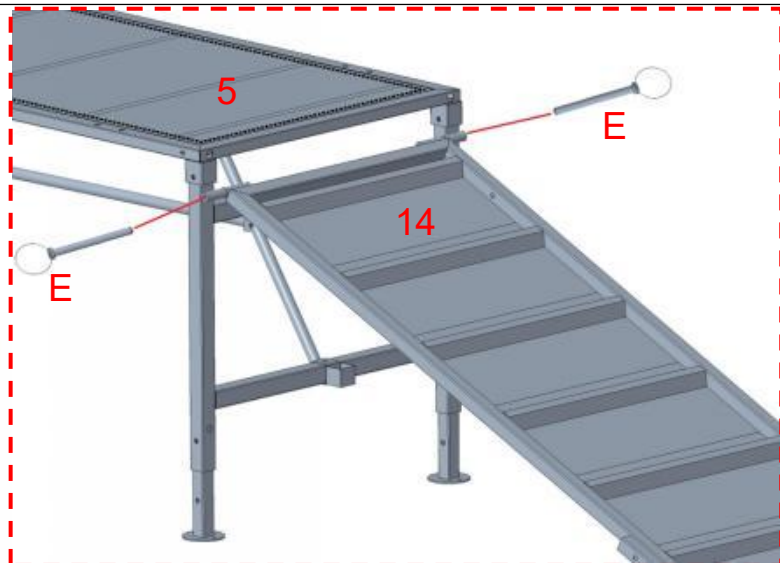
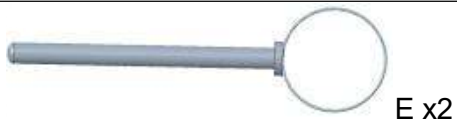

Säkra rampen (14) till bordsskivan (5) med stiften (E) .

Instruktioner för justering av huvudbandets bredd:



7. The fixed rack and movable rack are both equipped with 5 adjustment positions. The smaller the number, the narrower the spacing.
8. The upper and lower positions must be aligned to maintain a vertical state.
9. If you are unsure which position to choose, start with the middle position. If the goat's neck cannot be securely fixed, use a position with a smaller spacing.

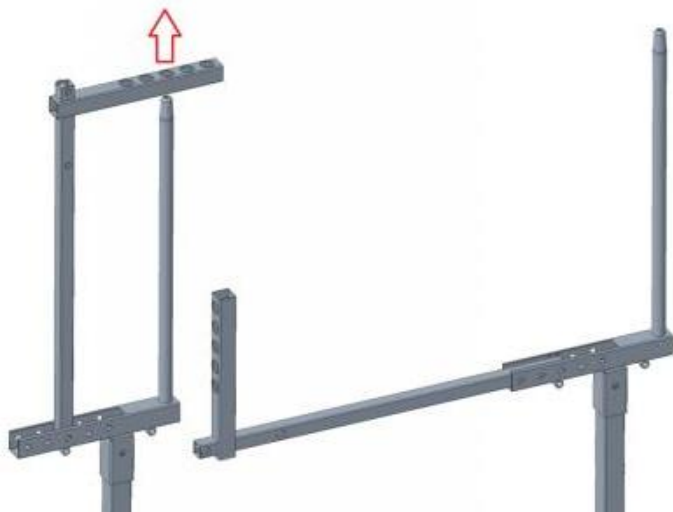

Lyft den rörliga tvärstången på gallret, rikta in den med det runda röret på det fasta gallret och sänk sedan ner det på plats.

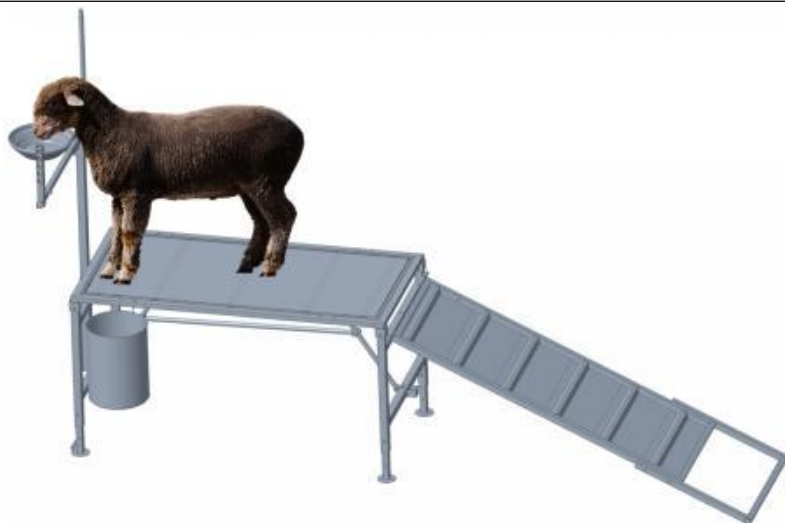

Öppna fästet och styr geten till det fasta stället .

Obs: Justera höjden på det fasta stället så att getens nedre nacke är i nivå med fästets nedre tvärstäng. Denna position gör att geten kan sänka huvudet för att dricka eller äta, och den kommer inte att vidröra den övre tvärstäng och orsaka rubbning när huvudet lyfts.



Lyft den rörliga tvärstäng på gallret, rikta in den med det runda röret på

det fasta gallret och sänk sedan ner det på plats.

PRODUCT PARAMETER

Modell	51*23 tum-B
Säker lastvikt	272 kg
Färg	Svart
Skrivbordsstorlek	51*23 tum (1295*584 mm)

Manufacturer: Shanghai Sishun Technology Co., Ltd
Address: 4th Floor, Building 2, No. 599 Wan Zhen Road, Zhenxin Xincun Subdistrict, Jiading District, Shanghai, 201800 China
E-mail: support@vevor.com

Imported to AUS: SIHAO PTY LTD. 1 ROKEVA STREET EASTWOOD NSW 2122 Australia

Imported to USA: Sarven Technology Ltd. Suite 250, 9166 Anaheim Place, Rancho Cucamonga, CA 91730

VEVOR SUPER TOOLS LIMITED

EC REP

Address: Office 403, NESTA Business Centre, 4-5 Burton Hall Rd, Sandyford, Dublin 18, D18 A094, Ireland

Email: service-eu@vevor.com Tel: +353874373999

VEVOR TOOL HUB LIMITED

UK REP

Address: 2 Goldstone Close, Brighton and Hove, BN3 7PD, United Kingdom

Email: service-uk@vevor.com Tel: +447795204660



VEVOR

Upgrade · The Home Creator Way

Veestal

Model : 51*23 inch-B

Model : 51*23 inch-B

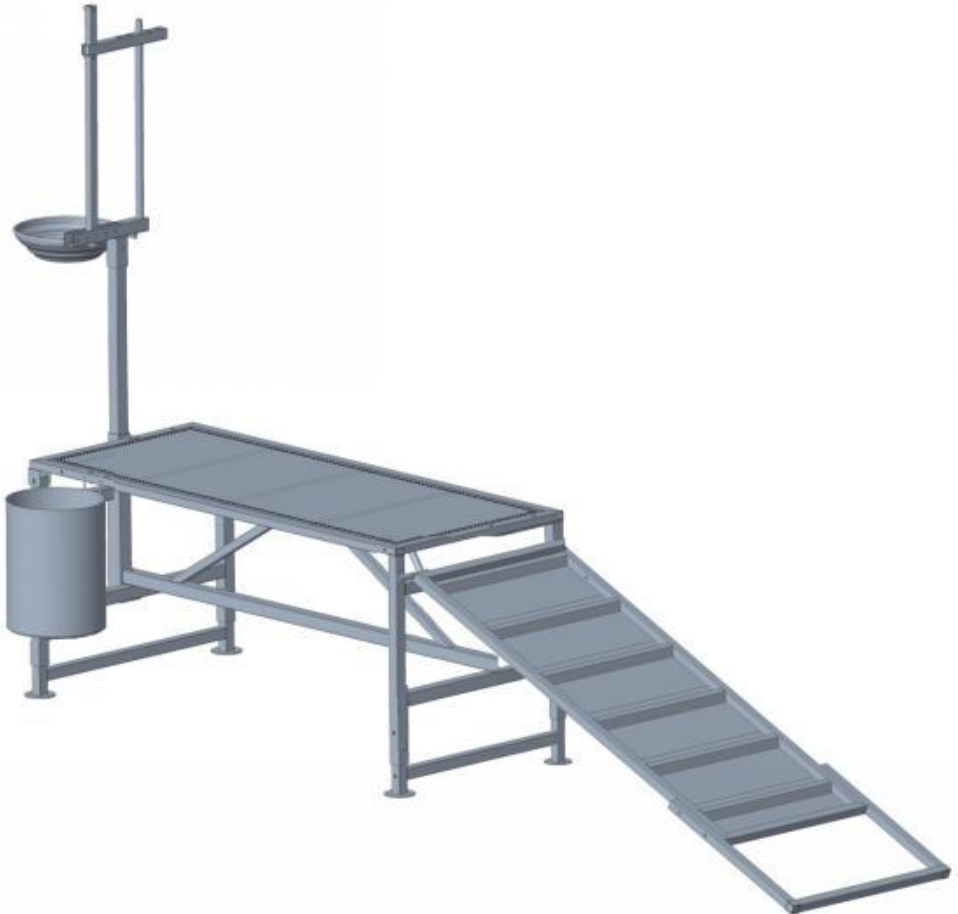

Dit is de originele handleiding. Lees alle instructies in de handleiding zorgvuldig door voordat u het product in gebruik neemt. VEVOR behoudt zich het recht voor om de gebruikershandleiding anders te interpreteren. Het uiterlijk van het product kan afwijken van het product dat u ontvangt. Wij zullen u niet opnieuw informeren over eventuele technologische of

software-updates voor ons product.

SAFETY INSTRUCTIONS

WAARSCHUWING:

Lees deze informatie voordat u dit product gebruikt. Het niet nalezen ervan kan ernstig letsel tot gevolg hebben.

Montagevoorzorgsmaatregelen

37. Monteer het product uitsluitend volgens deze instructies. Onjuiste montage kan gevaarlijke situaties veroorzaken.
38. Draag tijdens de montage een ANSI-goedgekeurde veiligheidsbril en stevige werkhandschoenen.
39. Zorg ervoor dat de montageruimte schoon en goed verlicht is.
40. Houd omstanders uit de buurt tijdens de bijeenkomst.
41. Niet monteren als u moe bent of onder invloed bent van alcohol, drugs of medicijnen.
42. De producteigenschappen gelden alleen voor correct en volledig geassembleerde producten.
43. standaard veilig kan dragen .
44. Raadpleeg voor meer informatie over de onderdelen die op de volgende pagina's worden vermeld, het montageschema in deze handleiding. Pak alle onderdelen uit en sorteer ze in een schone werkruimte.
45. Het product voldoet aan de relevante normen en voorschriften. De installatie van dit apparaat moet voldoen aan alle geldende voorschriften en het mag alleen worden gebruikt in goed geventileerde ruimtes. Lees de gebruikershandleiding voordat u dit apparaat installeert en gebruikt.
46. Dit apparaat is niet bedoeld voor gebruik door personen (inclusief kinderen) met beperkte fysieke, zintuiglijke of mentale vermogens, of die onvoldoende ervaring en kennis hebben, tenzij zij onder toezicht staan of instructies hebben gekregen over het gebruik van het apparaat van een persoon die verantwoordelijk is voor hun veiligheid.
47. Dit apparaat is bedoeld voor gebruik in huishoudens en soortgelijke

toepassingen, zoals:

- boerderijen;

48. Bewaar het product op de juiste manier. Controleer vóór gebruik of het product niet defect is. Stop het gebruik als er een defect is.

Neem voorzorgsmaatregelen.

16. NIET OP DIT ARTIKEL ZITTEN OF STAAN.

17. Dit product is geen speelgoed. Laat kinderen niet met dit product spelen en laat ze er niet in de buurt komen.







18. De aangegeven waarde niet overschrijden. draagvermogen.











19. Gebruik uitsluitend zoals bedoeld.

20. Controleer het product voor elk gebruik; gebruik het product niet als onderdelen loszitten of beschadigd zijn.

BEWAAR DEZE HANDLEIDING

PARTS LIST

Nee .	Deel	Naam	Aanta l.
1		Verplaatsbaar rek	1
2		Vaste rek	1
3		Lange stok	1
4		Vaste stang	1
5		Tafelblad	1
6		Verstelbare poot A	2
7		Verstelbare poot B	1
7-1		Verstelbare poot B	1
8		Ronde hoepel	1

9		Bekken	1
Nee	Deel	Naam	Aanta l.
10		Gereedschapstas	1
11		Drijfstang	1
12		helling	1
13		U-vormige paal	1
A		Snelontgrendelingsp en	5
B		Kunststof knop	7
C		Schroef M8*45mm	8
D		Moer M8	16
E		Snelontgrendelingsp en	2
F		Schroef M8*60mm	4

G		Schroef M8*80mm	2
---	--	--------------------	---

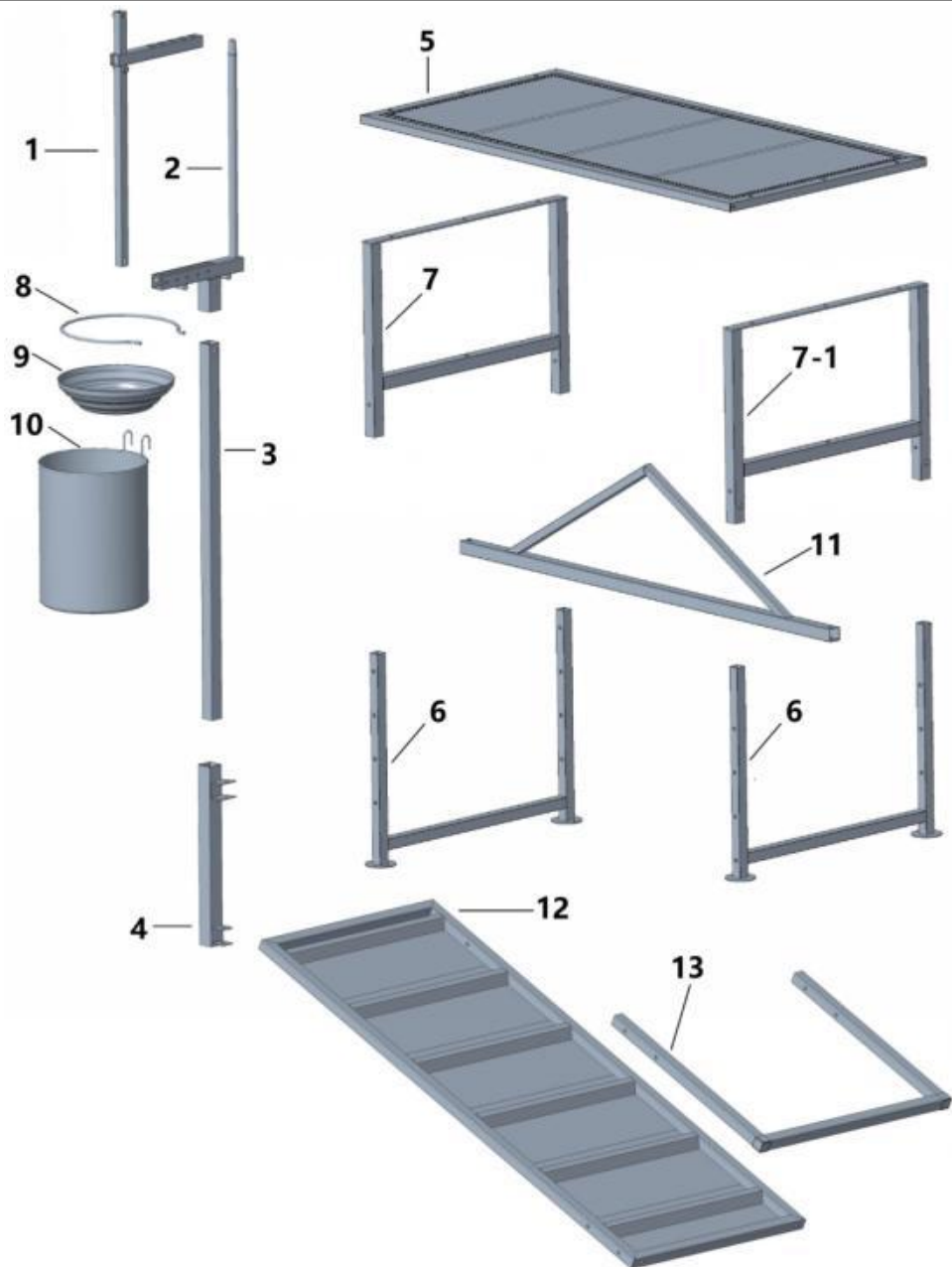

ASSEMBLY STEP

STAP 1



5 x1



7 x1



7-1 x1 M8*35mm



C x5



D x5

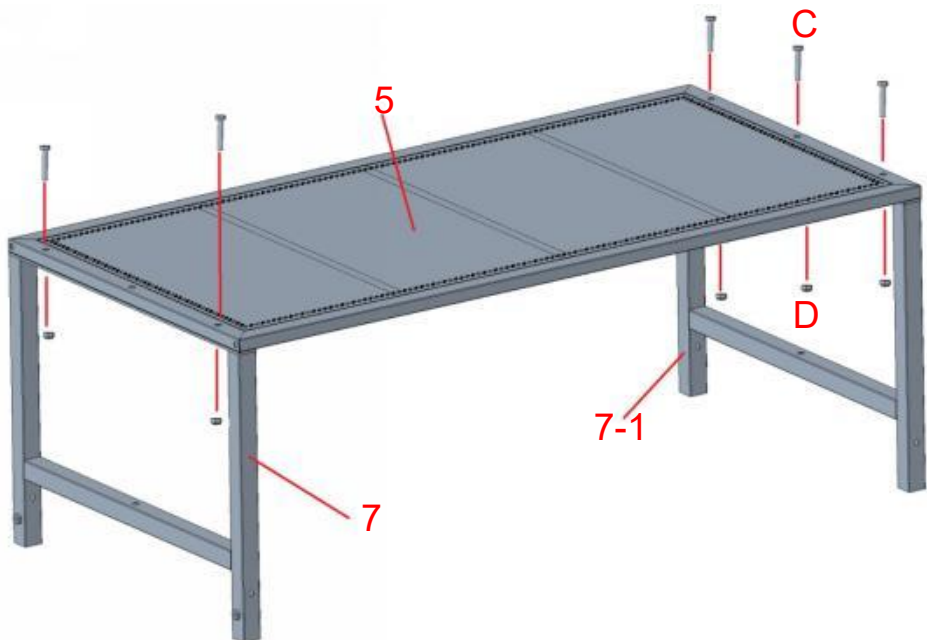

Bevestig de verstelbare poot B (7) aan het tafelblad (5) met schroeven (C) .

STAP 2



4 x1



11 X1

M8*35mm



C x2



D x4 M8*70mm



F x2

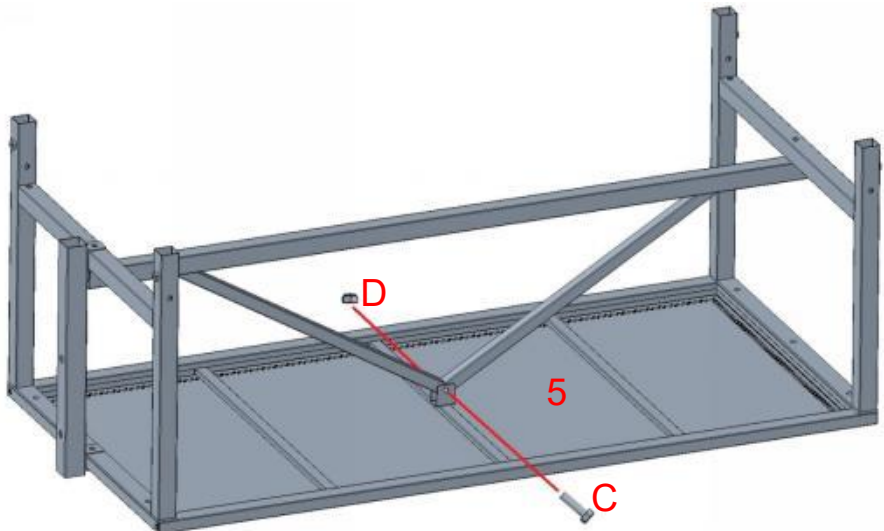
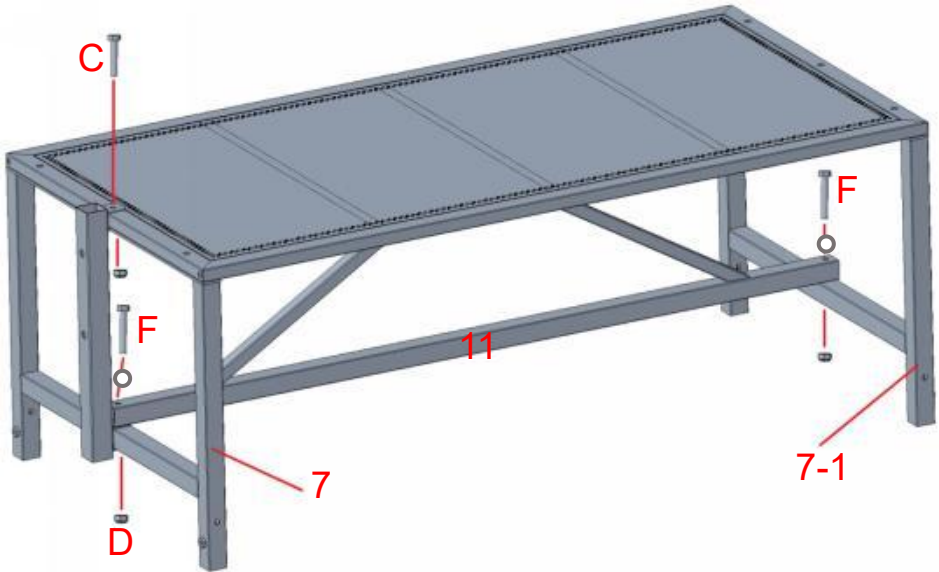

Bevestig de vaste stang (4) en verbindingstang (11) naar het tafelblad (5)

met schroeven (C en H) .

STAP 3

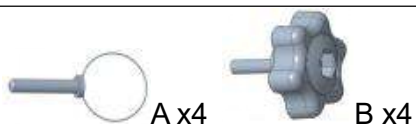

C

12

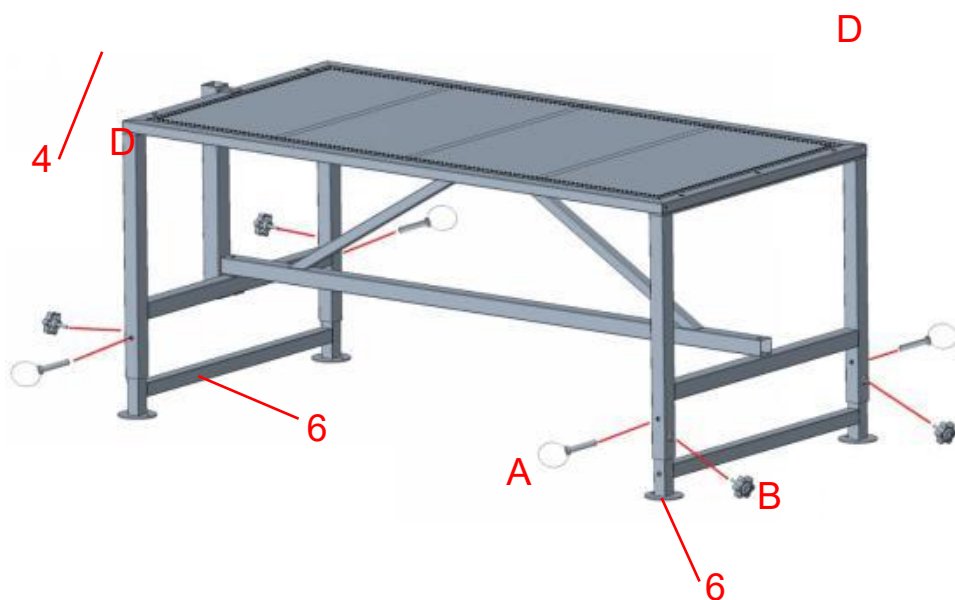

Steek de verstelbare poot A (6) in de steunpoot en bevestig deze met de pen (A) en de plastic knop (B) .

STAP 4

3 x 1

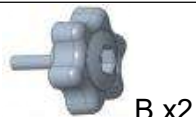

B x 2

Note the
direction.



3

B

4

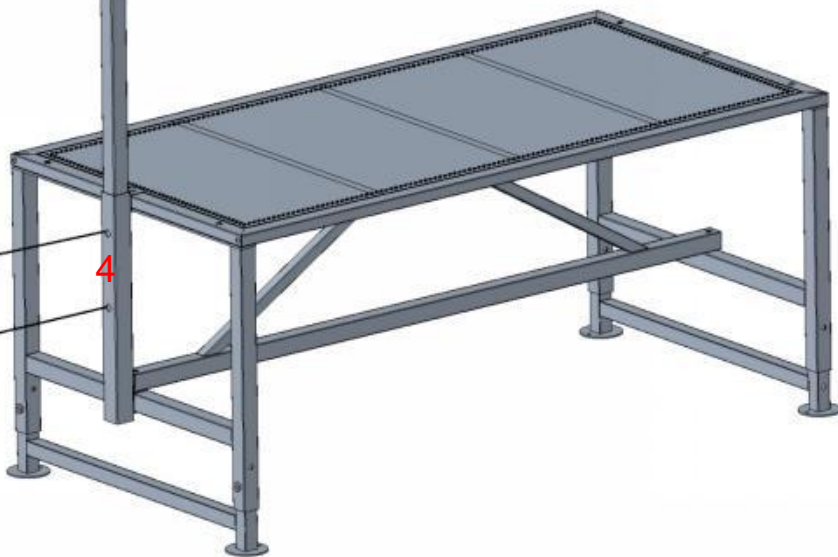

Steek de lange stang (3) in de vaste buis (4) en zet hem vast met de plastic knop (B) .

Opmerking: 1. Steek de lange paal erin volgens de richting die in het diagram is aangegeven.

2. De hoogte van het gehele geitenkoprek kan worden aangepast door de plastic knop los te draaien of vast te zetten, waardoor de lange stang

omhoog en omlaag kan worden bewogen.

STAP 5-1

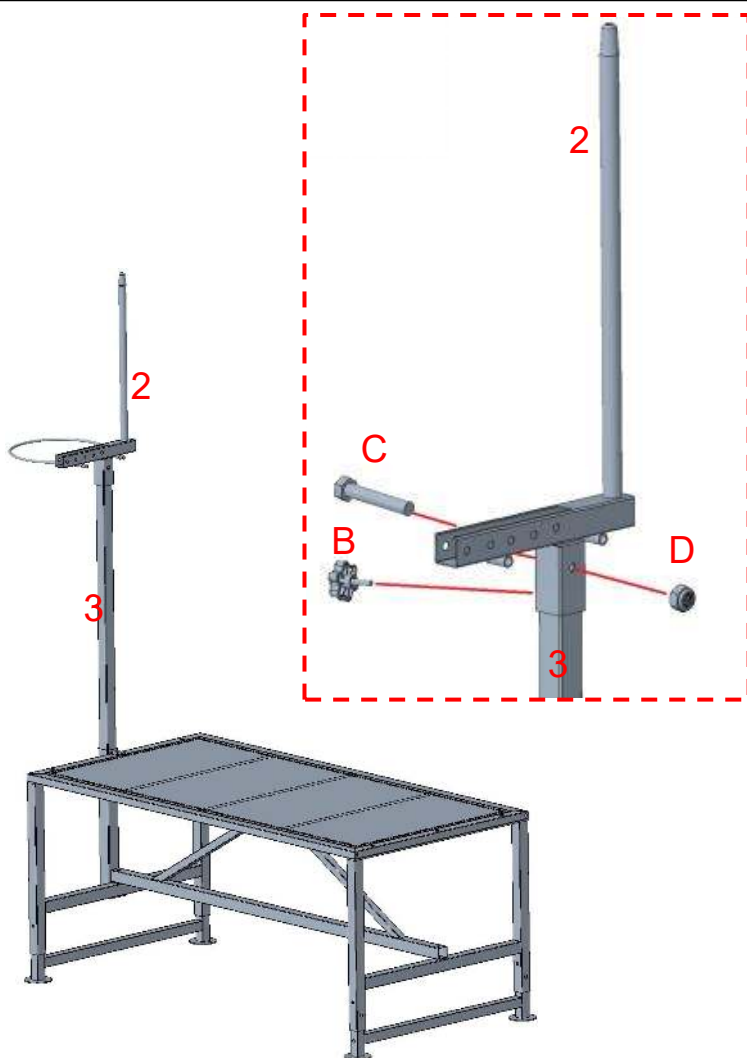
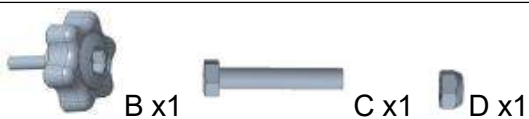

montagebeugel voor de geitenkop (2) aan de lange paal (3) met schroef

(C) en plastic knop (B) .

STAP 5-2

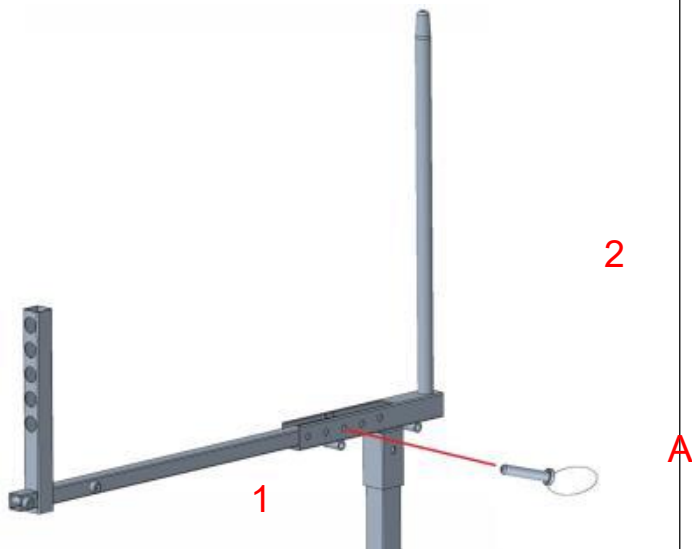

movable rack

Steek de (1) in de montagebeugel van de geitenkop (2) en zet deze vast met een pen (A) .

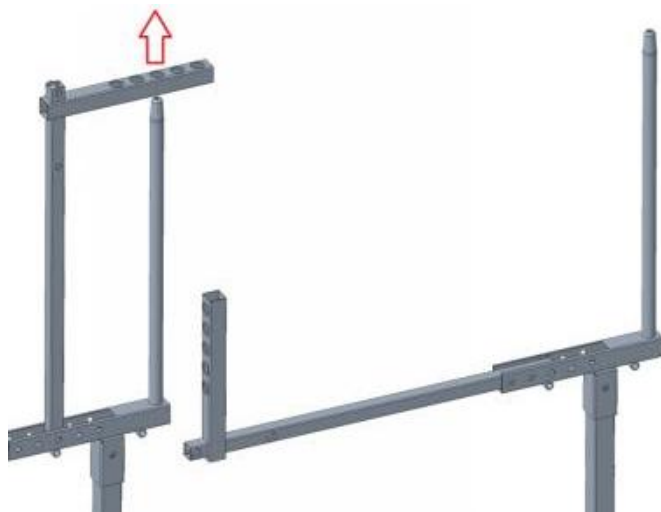

Til de beweegbare dwarsbalk van het rek op, lijn deze uit met de ronde

buis van het vaste rek en laat hem vervolgens op zijn plaats zakken.

STAP 6

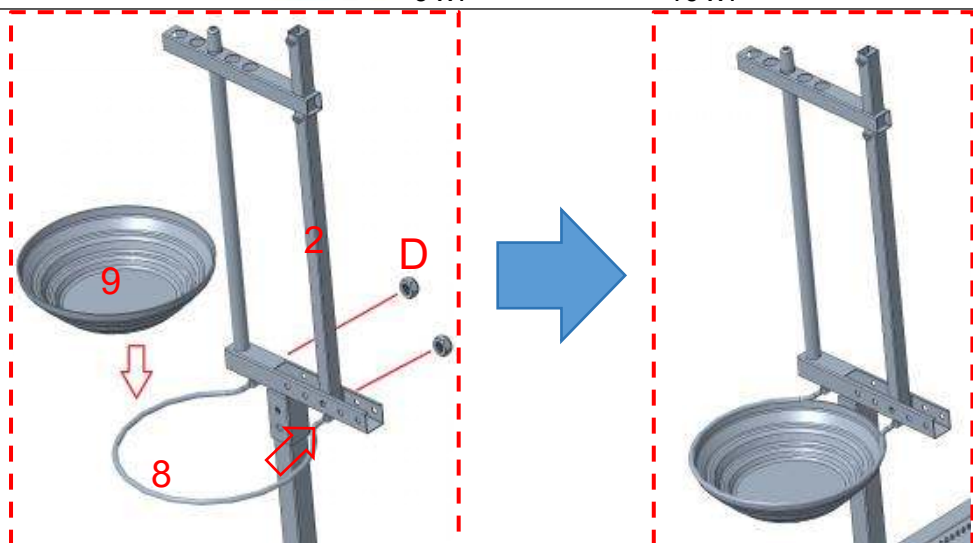
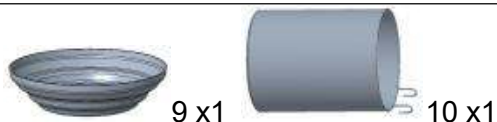

1. Steek de ronde ring (8) door de montagebeugel met geitenkop (2) en draai deze vast met de schroeven (D) .
2. Plaats de kom (9) op de ronde ring voor het bewaren van water of voer.

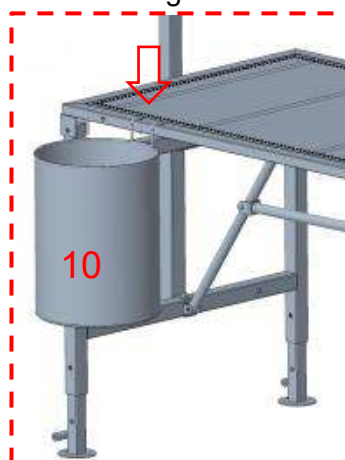

3. Hang de gereedschapstas (10) aan het platform. Het platform is

voorzien van 4 posities voor flexibele aanpassing aan de gebruiksgewoonten.

STAP 7

M8*70mm

F x4

D x4



14 x1



15 x1

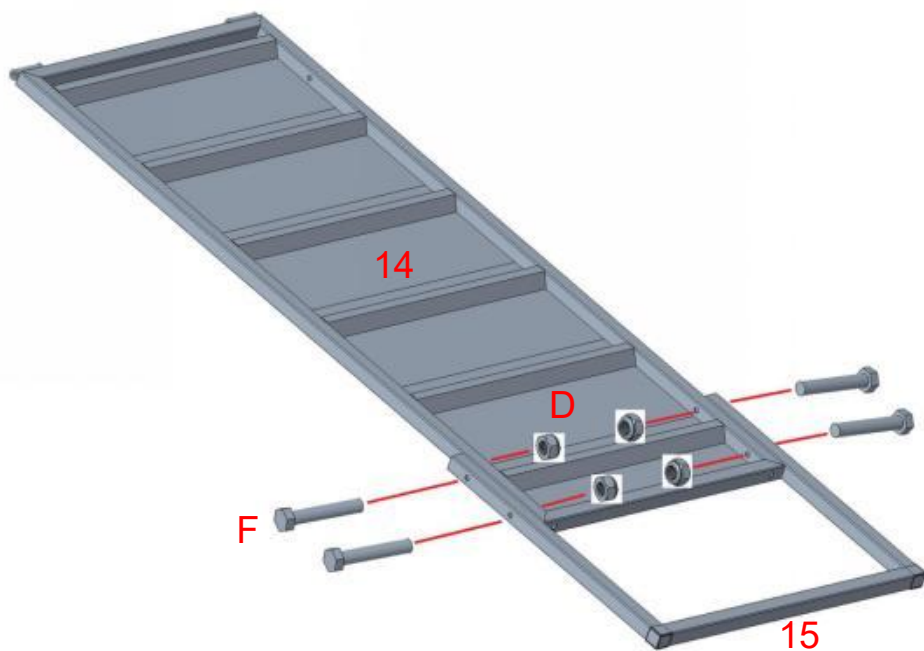

Bevestig de U-vormige paal (15) aan de helling (14) met schroeven (F) .

STAP 8

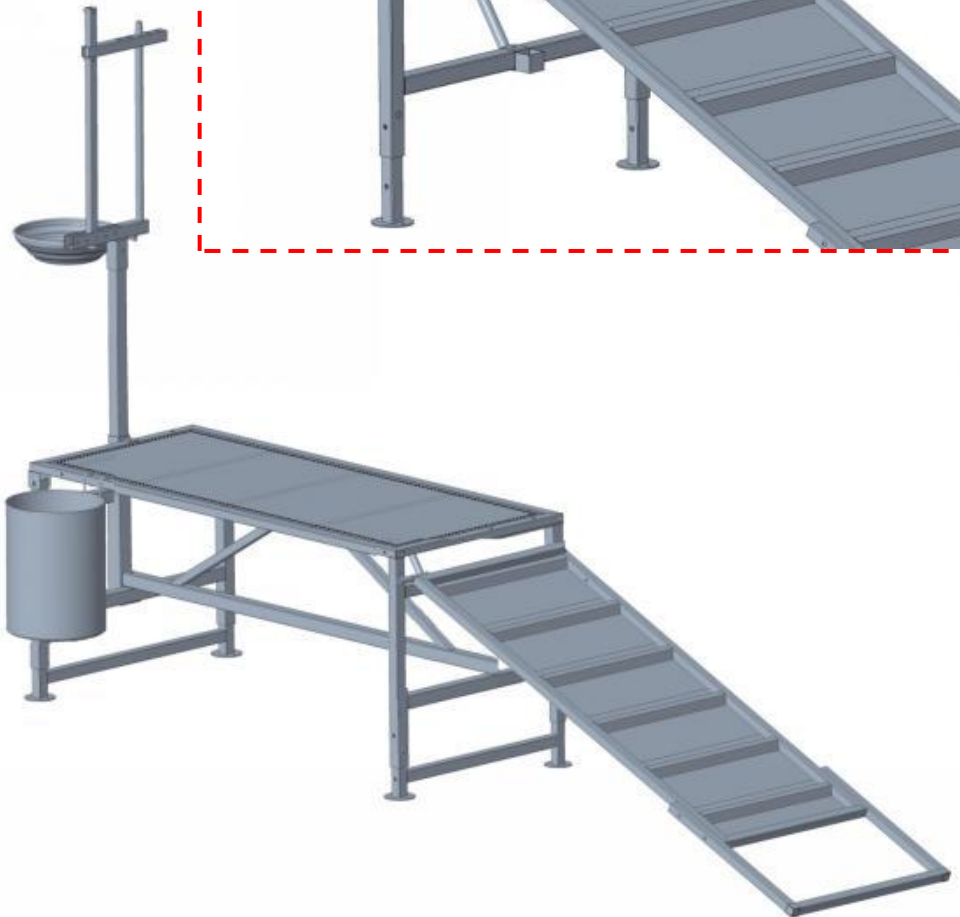
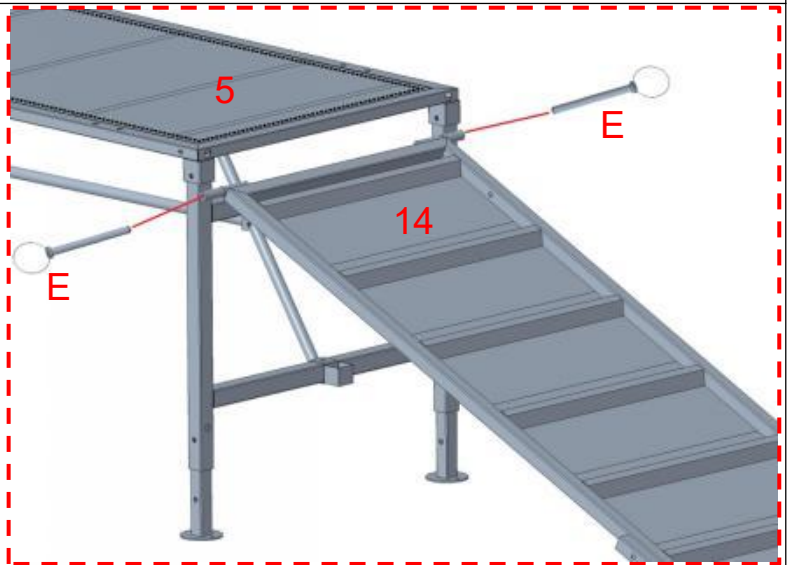

Beveilig de helling (14) naar het tafelblad (5) met pinnen (E) .

Instructies voor het aanpassen van de breedte van de hoofdband:



10. The fixed rack and movable rack are both equipped with 5 adjustment positions. The smaller the number, the narrower the spacing.
11. The upper and lower positions must be aligned to maintain a vertical state.
12. If you are unsure which position to choose, start with the middle position. If the goat's neck cannot be securely fixed, use a position with a smaller spacing.

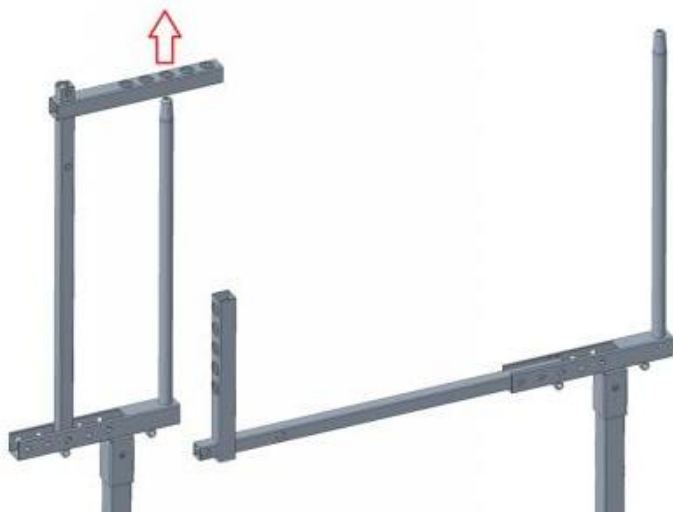

Til de beweegbare dwarsbalk van het rek op, lijn deze uit met de ronde

buis van het vaste rek en laat hem vervolgens op zijn plaats zakken.



Open de beugel en leid de geit naar het vaste rek .

Let op: Stel de hoogte van het vaste rek zo in dat de onderkant van de nek van de geit gelijk ligt met de onderste dwarsbalk van de beugel. In deze positie kan de geit haar kop laten zakken om te drinken of te eten, zonder dat deze de bovenste dwarsbalk raakt wanneer ze haar kop weer optilt.



Til de beweegbare dwarsbalk van het rek op, lijn deze uit met de ronde buis van het vaste rek en laat hem vervolgens op zijn plaats zakken.

PRODUCT PARAMETER

Model	51*23 inch-B
Veilig laadgewicht	600 lbs/272 kg
Kleur	Zwart
Desktopformaat	51*23 inch (1295*584 mm)

Manufacturer: Shanghai Sishun Technology Co., Ltd
Address: 4th Floor, Building 2, No. 599 Wan Zhen Road, Zhenxin Xincun Subdistrict, Jiading District, Shanghai, 201800 China
E-mail: support@vevor.com

Imported to AUS: SIHAO PTY LTD. 1 ROKEVA STREET EASTWOOD NSW 2122 Australia

Imported to USA: Sarven Technology Ltd. Suite 250, 9166 Anaheim Place, Rancho Cucamonga, CA 91730

VEVOR SUPER TOOLS LIMITED

EC REP

Address: Office 403, NESTA Business Centre, 4-5 Burton Hall Rd, Sandyford, Dublin 18, D18 A094, Ireland

Email: service-eu@vevor.com Tel: +353874373999

VEVOR TOOL HUB LIMITED

UK REP

Address: 2 Goldstone Close, Brighton and Hove, BN3 7PD, United Kingdom

Email: service-uk@vevor.com Tel: +447795204660



VEVOR

Upgrade · The Home Creator Way

Parc à bétail

Modèle : 51*23 pouces-B

Modèle : 51*23 pouces-B

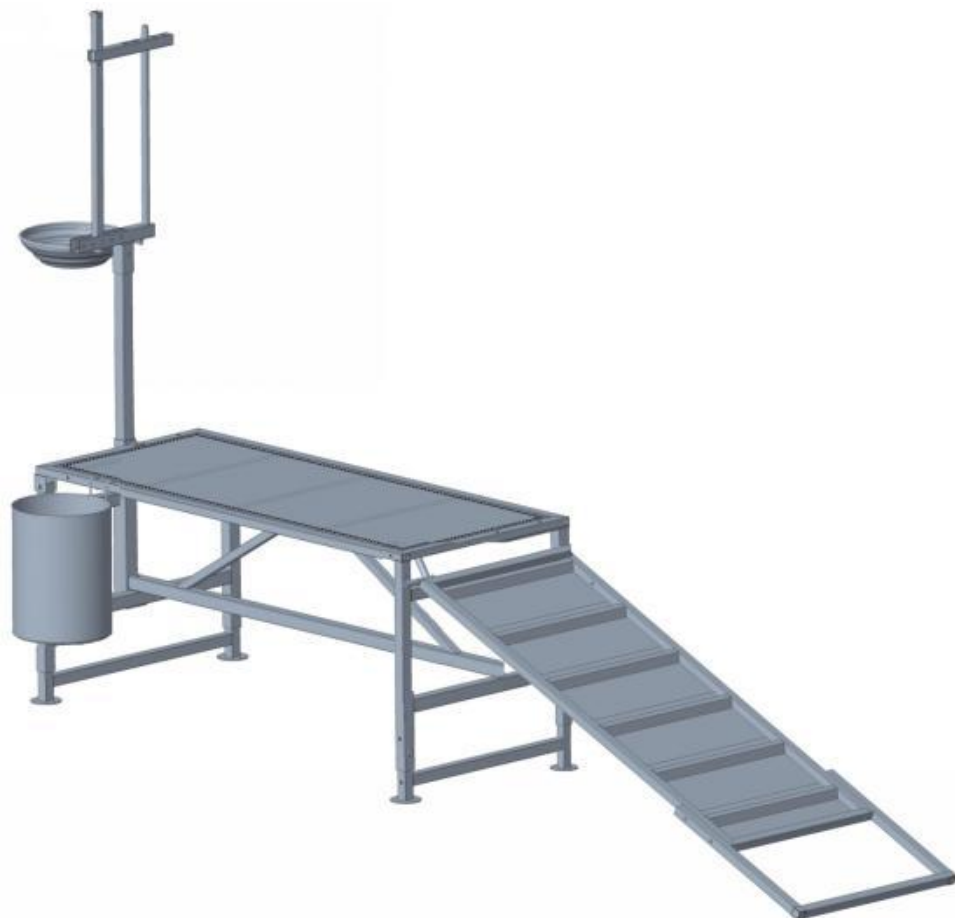

Voici le mode d'emploi original. Veuillez lire attentivement toutes les instructions du manuel avant utilisation. VEVOR se réserve le droit d'interpréter ce manuel à sa guise. L'apparence du produit que vous recevrez peut différer. Nous vous prions de nous excuser si nous ne vous informons pas des mises à jour techniques ou logicielles concernant notre

produit.

SAFETY INSTRUCTIONS

AVERTISSEMENT:

Veillez lire attentivement cette notice avant d'utiliser ce produit. Le non-respect de cette consigne peut entraîner des blessures graves.

précautions d'assemblage

49. Assembler uniquement selon ces instructions. Un assemblage incorrect peut engendrer des risques.
50. Portez des lunettes de sécurité homologuées ANSI et des gants de travail robustes pendant l'assemblage.
51. Maintenez la zone de rassemblement propre et bien éclairée.
52. Tenir les curieux à l'écart de la zone pendant le rassemblement.
53. Ne pas assembler en cas de fatigue ou sous l'influence de l'alcool, de drogues ou de médicaments.
54. Les capacités du produit s'appliquent uniquement aux produits correctement et entièrement assemblés.
55. Assembler sur une surface plane, de niveau, dure et lisse capable de supporter en toute sécurité le support pour béton.
56. Pour plus d'informations concernant les pièces mentionnées dans les pages suivantes, veuillez vous référer au schéma de montage de ce manuel. Déballez et séparez toutes les pièces dans un espace de travail propre.
57. Ce produit est conforme aux normes et réglementations en vigueur. Son installation doit respecter toutes les réglementations applicables et son utilisation doit se faire uniquement dans des endroits bien ventilés. Veuillez lire attentivement le manuel d'utilisation avant d'installer et d'utiliser cet équipement.
58. Cet appareil n'est pas destiné à être utilisé par des personnes (y compris les enfants) dont les capacités physiques, sensorielles ou mentales sont réduites, ou qui manquent d'expérience et de connaissances, à moins qu'elles n'aient été supervisées ou qu'elles n'aient reçu des instructions concernant l'utilisation de l'appareil de la

part d'une personne responsable de leur sécurité.

59. Cet appareil est destiné à être utilisé dans des applications domestiques et similaires telles que :
- les fermes ;
60. Veuillez conserver le produit correctement. Vérifiez que le produit n'est pas anormal avant utilisation. Si c'est le cas, veuillez cesser de l'utiliser.











Prenez des précautions



21. NE PAS S'ASSEOIR NI SE TENIR DEBOUT SUR CET OBJET.
22. Ce produit n'est pas un jouet. Ne laissez pas les enfants jouer avec ou à proximité de cet article.
23. Ne pas dépasser les spécifications capacités de poids.
24. Utiliser uniquement conformément à l'usage prévu.
25. Inspecter avant chaque utilisation ; ne pas utiliser si des pièces sont desserrées ou endommagées.

CONSERVEZ CE MANUEL

PARTS LIST

Non.	Partie	Nom	Qté.
1		Étagère mobile	1
2		rack fixe	1
3		Longue perche	1
4		Tige fixe	1
5		Table	1
6		Pied réglable A	2
7		Pied réglable B	1
7-1		Pied réglable B	1

8		cerceau circulaire	1
9		Bassin	1
Non.	Partie	Nom	Qté.
10		sac à outils	1
11		bielle	1
12		Rampe	1
13		Poteau en forme de U	1
UN		goupille à dégagement rapide	5
B		Bouton en plastique	7
C		Vis M8*45 mm	8
D		Noix M8	16
E		goupille à dégagement rapide	2

F		Vis M8*60 mm	4
G		Vis M8*80 mm	2

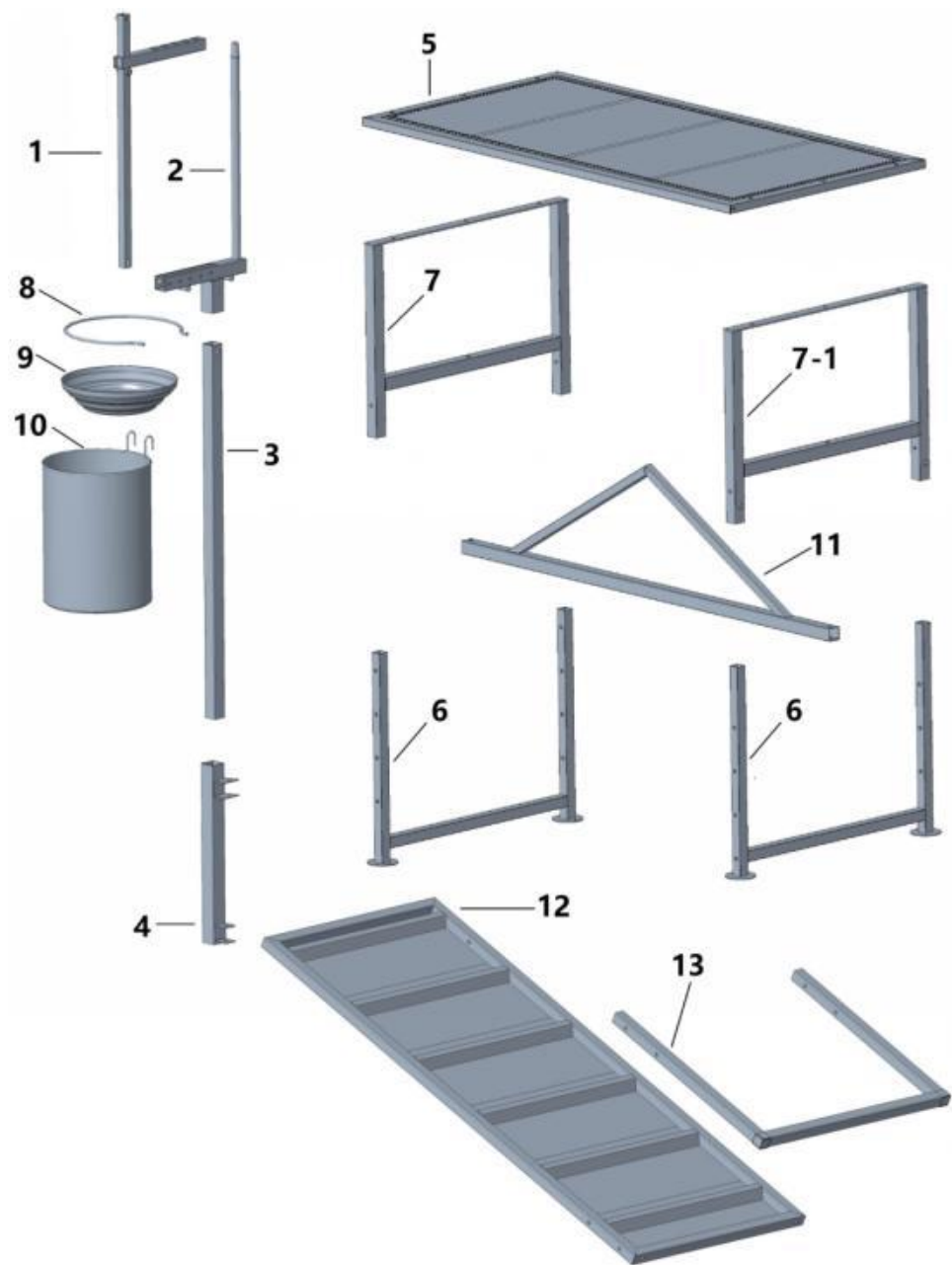

ASSEMBLY STEP

ÉTAPE 1

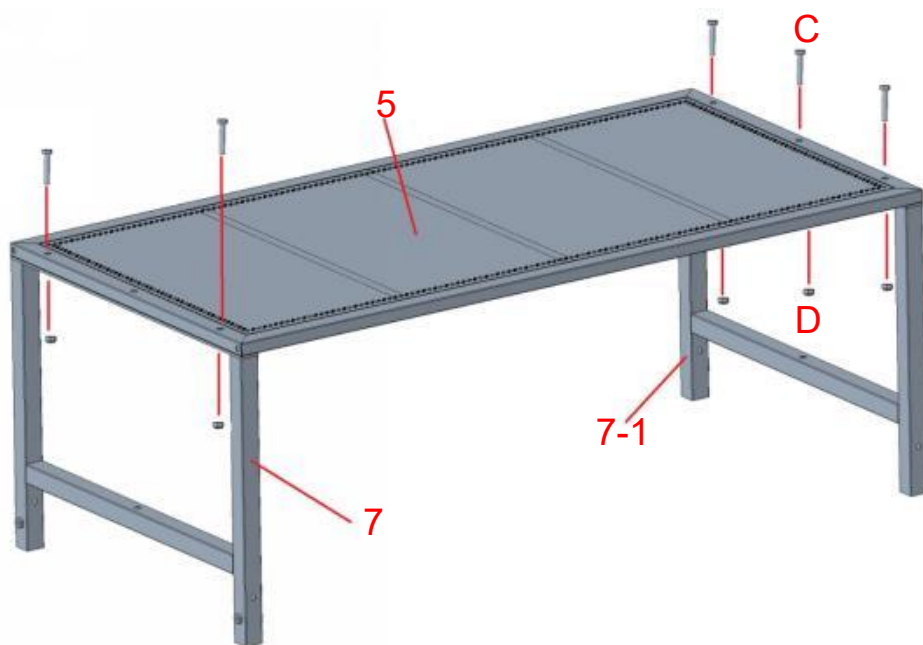
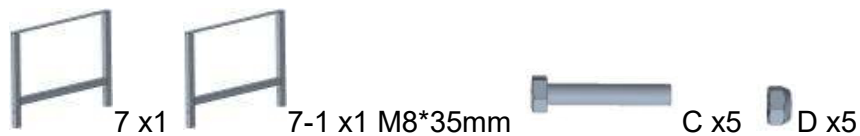

Fixez le pied réglable B (7) au plateau de table (5) avec des vis (C) .

ÉTAPE 2



4 x1



11 X1

M8*35mm



C x2



D x4 M8*70mm



F x2

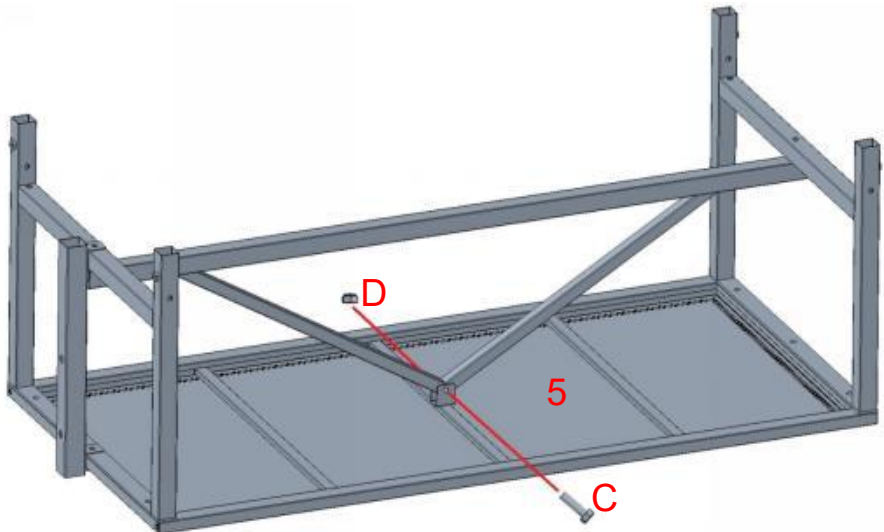
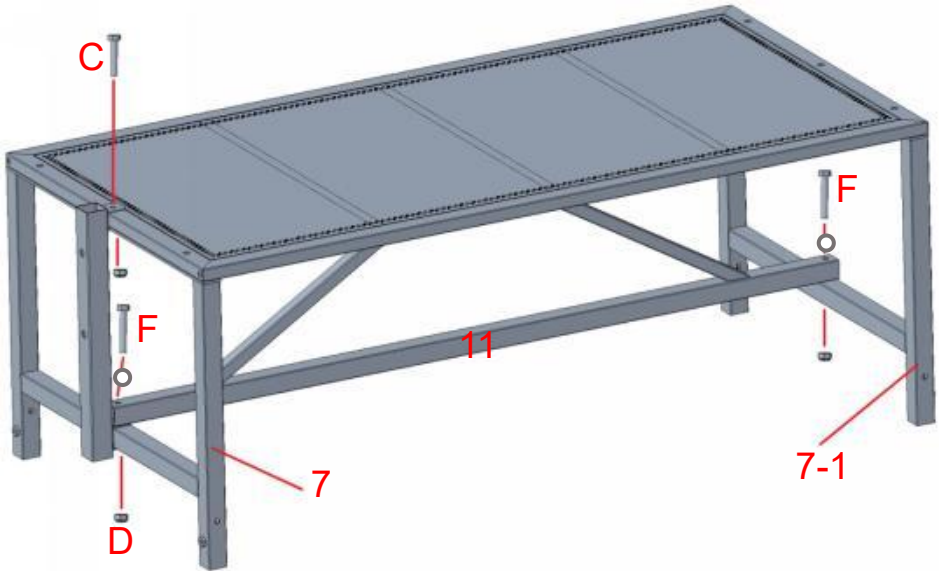

Fixez la tige fixe (4) et la tige de liaison (11) au plateau de table (5) avec des vis (C et H) .

ÉTAPE 3

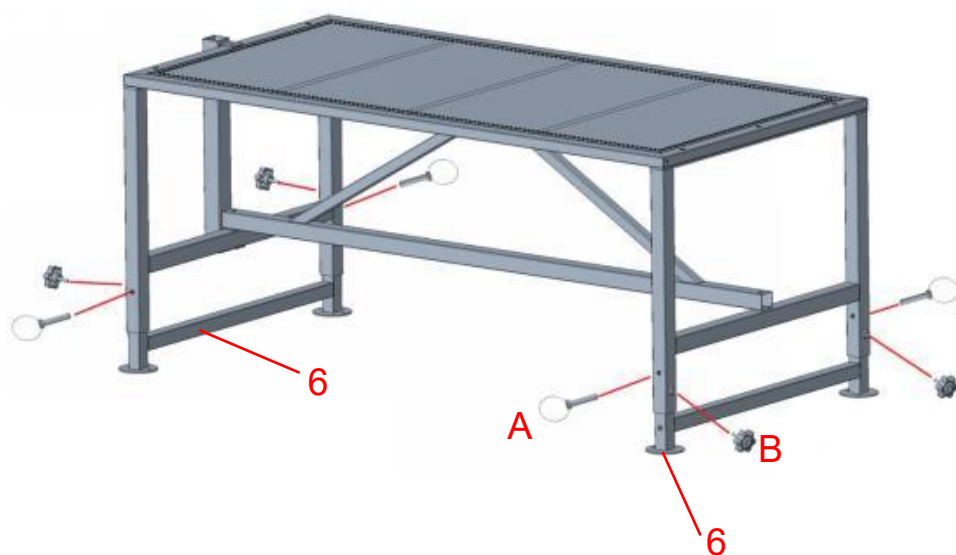
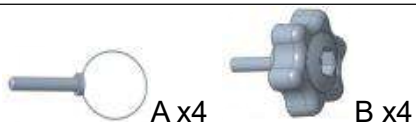

Insérez le pied réglable A (6) dans le pied de support et fixez-le avec la goupille (A) et le bouton en plastique (B) .

ÉTAPE 4

3 x 1



B x 2

Note the
direction.



3

B

4

Insérez le long poteau (3) dans le tube fixe (4) et fixez-le avec le bouton en plastique (B) .

Remarque : 1. Insérez le long poteau selon la direction indiquée sur le schéma.

2. La hauteur de l'ensemble du support pour tête de chèvre peut être ajustée en desserrant ou en serrant le bouton en plastique pour déplacer le

long poteau de haut en bas.

ÉTAPE

5-1

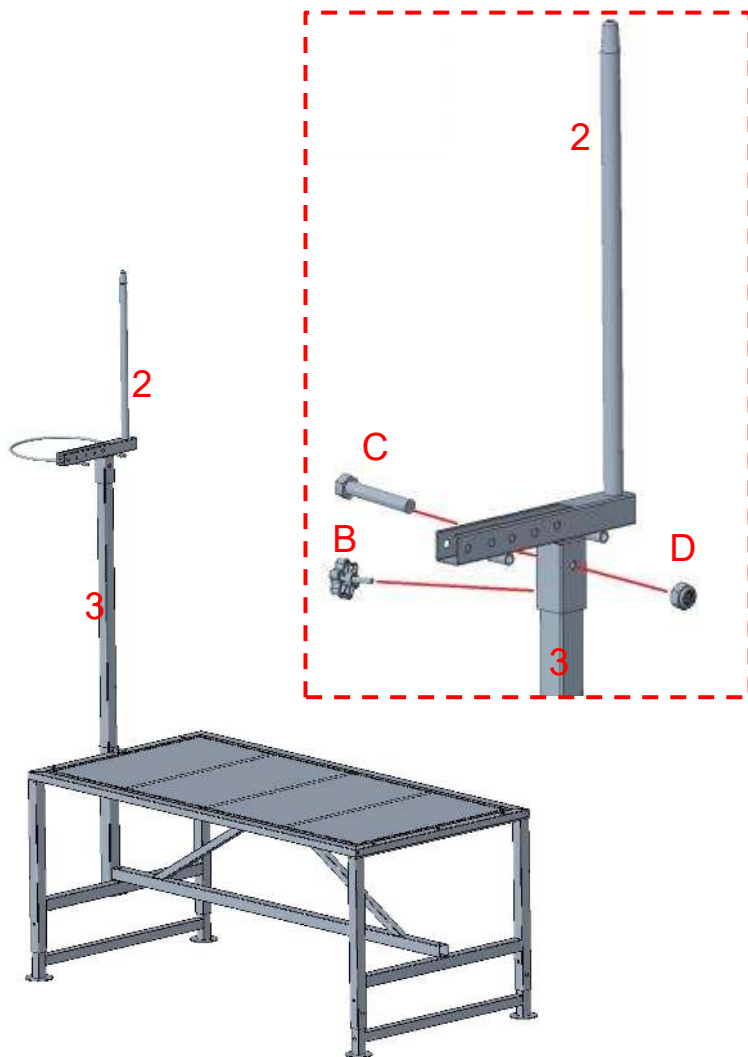

Fixez le support de montage de la tête de chèvre (2) au long poteau (3) avec la vis (C) et le bouton en plastique (B) .

ÉTAPE

5-2



1 x1



A x1

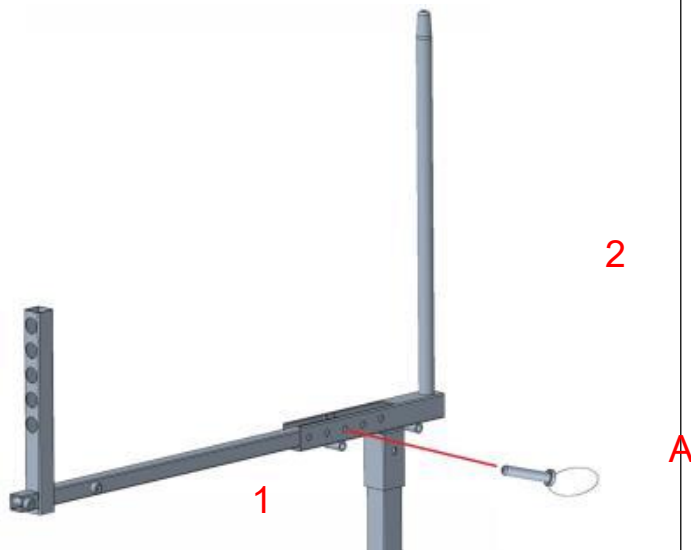

movable rack

Insérez le (1) dans le support de montage de la tête de chèvre (2) et fixez-le avec une goupille (A) .

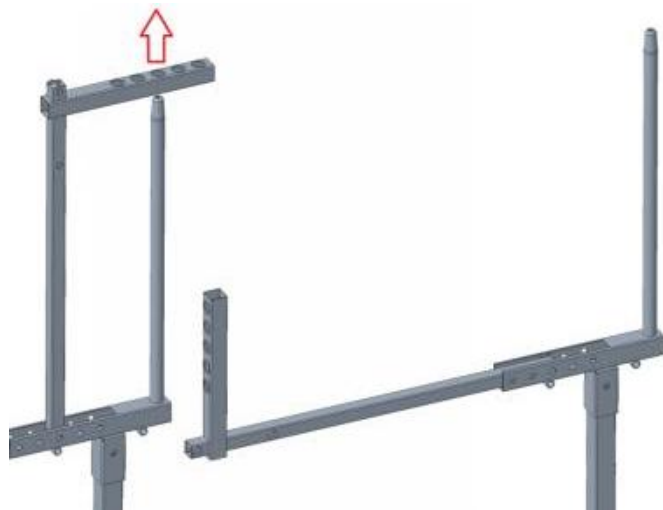

Soulevez la barre transversale mobile du porte-bagages , alignez-la avec le tube rond du porte-bagages fixe , puis abaissez-la en place.

ÉTAPE 6

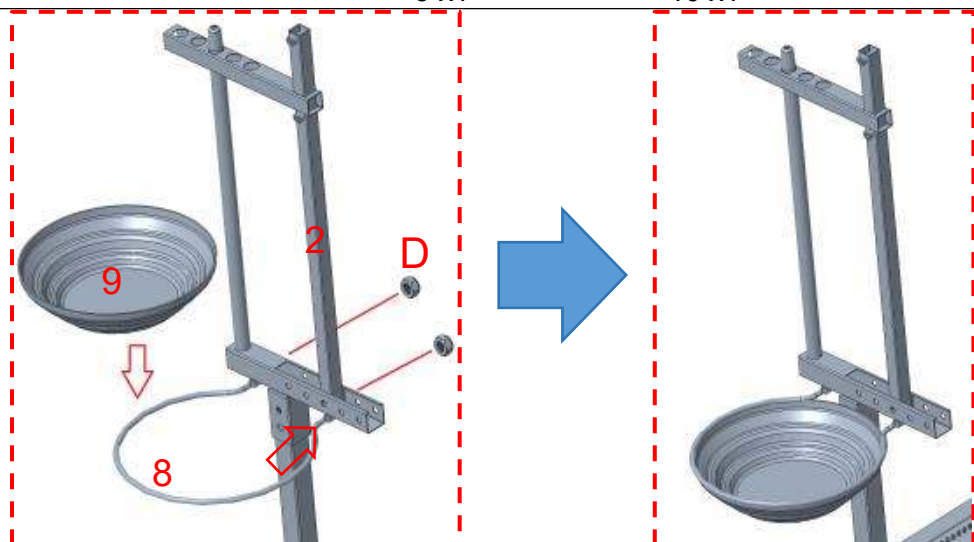

1. Insérez l'anneau circulaire (8) à travers le support de montage de la tête

de chèvre (2) et serrez-le avec les vis (D) .

2. Placez le bassin (9) sur l'anneau circulaire pour contenir l'eau ou le fourrage.

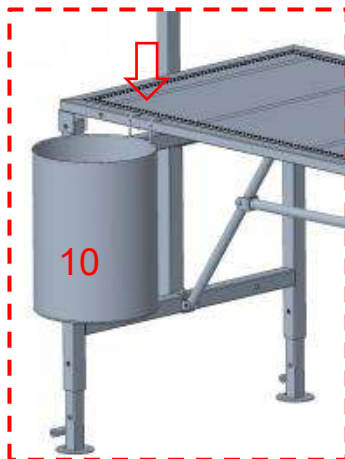

3. Accrochez le sac à outils (10) sur la plateforme. La plateforme est équipée de 4 positions pour un réglage flexible selon les habitudes d'utilisation.

ÉTAPE 7

M8*70mm



F x4



D x4



14 x1



15 x1

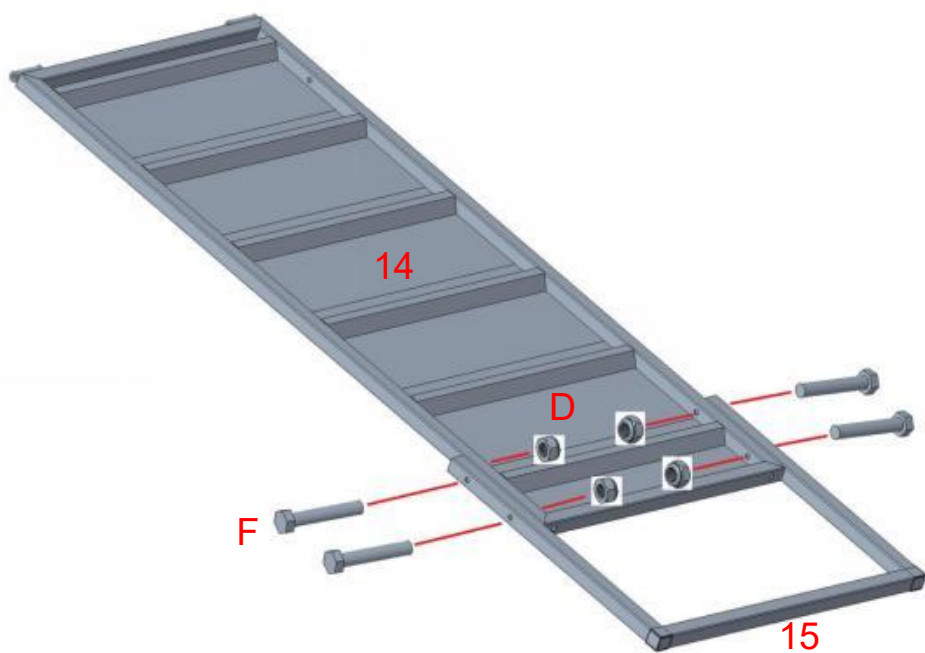

Fixez le poteau en forme de U (15) à la rampe (14) avec des vis (F) .

ÉTAPE 8

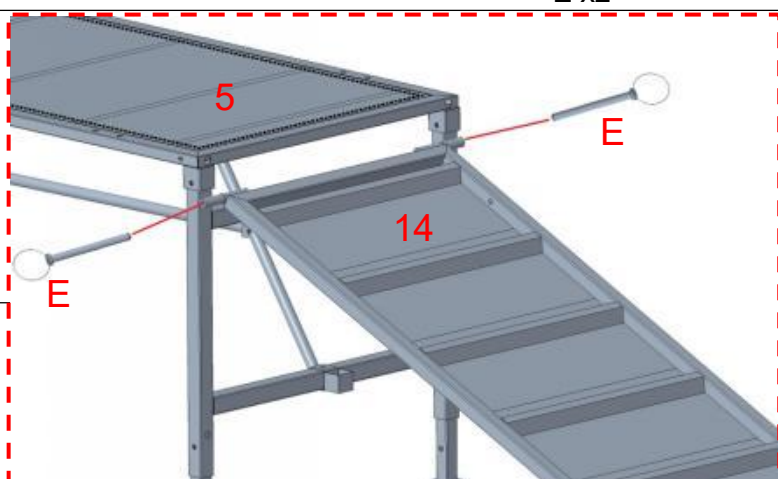

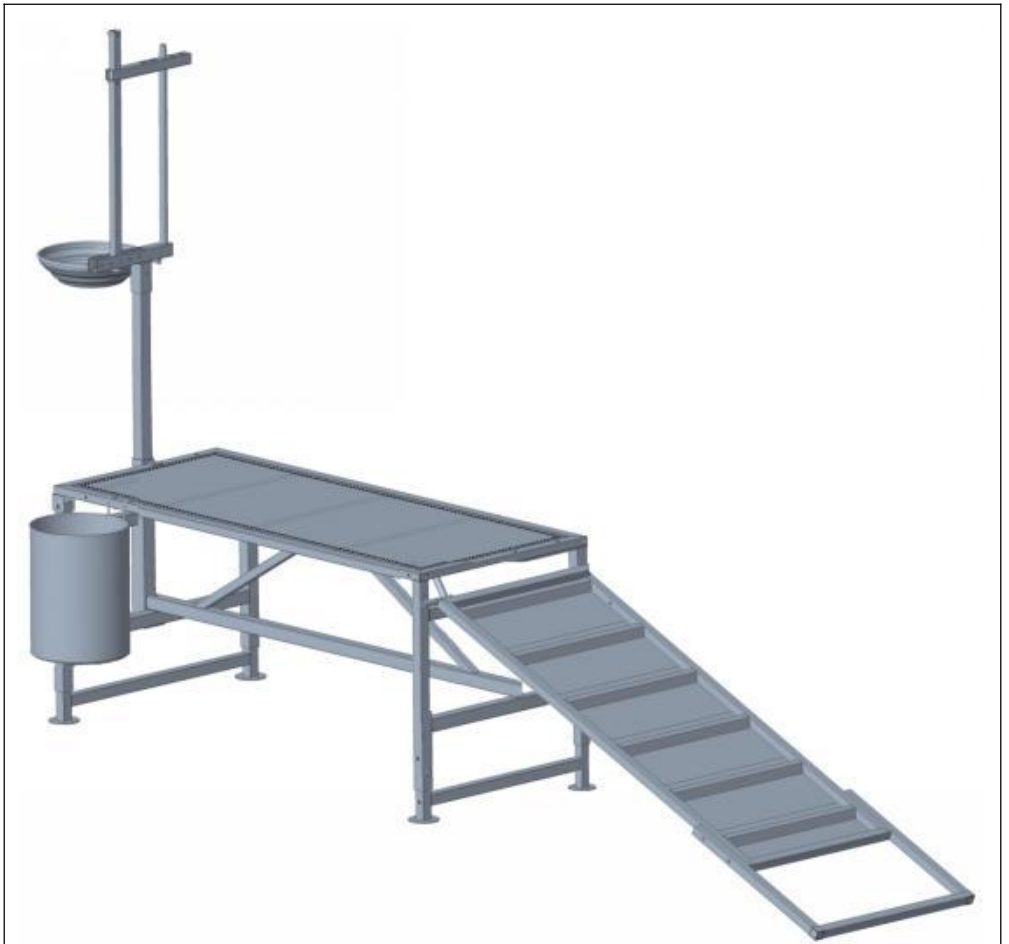

Sécuriser rampe (14) vers le plateau de table (5) avec des broches (E) .

Instructions de réglage de la largeur du bandeau :



13. The fixed rack and movable rack are both equipped with 5 adjustment positions. The smaller the number, the narrower the spacing.
14. The upper and lower positions must be aligned to maintain a vertical state.
15. If you are unsure which position to choose, start with the middle position. If the goat's neck cannot be securely fixed, use a position with a smaller spacing.

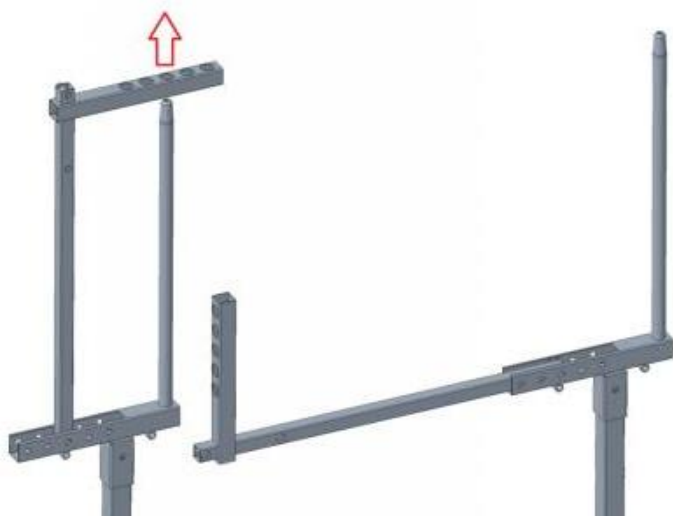

Soulevez la barre transversale mobile du porte-bagages , alignez-la avec le tube rond du porte-bagages fixe , puis abaissez-la en place.

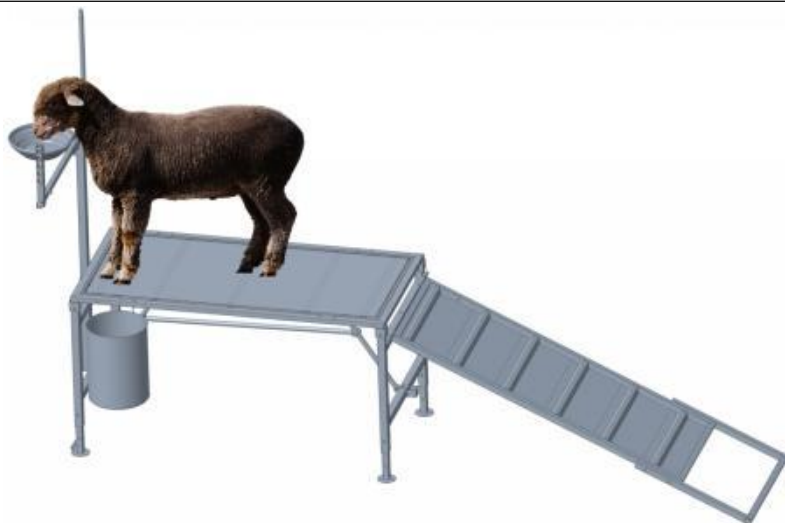

Ouvrez le support et guidez la chèvre vers le râtelier fixe .

Remarque : Ajustez la hauteur du support fixe de façon à ce que le bas du cou de la chèvre soit au niveau de la barre transversale inférieure. Ainsi, la chèvre peut baisser la tête pour boire ou manger sans risquer de se déséquilibrer en relevant la tête.



Soulevez la barre transversale mobile du porte-bagages , alignez-la avec

le tube rond du porte-bagages fixe , puis abaissez-la en place.

PRODUCT PARAMETER

Modèle	51*23 pouces-B
Poids de charge admissible	600 lb/272 kg
Couleur	Noir
Taille du bureau	51*23 pouces (1295*584 mm)

Manufacturer: Shanghai Sishun Technology Co., Ltd
Address: 4th Floor, Building 2, No. 599 Wan Zhen Road, Zhenxin Xincun Subdistrict, Jiading District, Shanghai, 201800 China
E-mail: support@vevor.com

Imported to AUS: SIHAO PTY LTD. 1 ROKEVA STREET EASTWOOD NSW 2122 Australia

Imported to USA: Sarven Technology Ltd. Suite 250, 9166 Anaheim Place, Rancho Cucamonga, CA 91730

VEVOR SUPER TOOLS LIMITED

EC REP

Address: Office 403, NESTA Business Centre, 4-5 Burton Hall Rd, Sandyford, Dublin 18, D18 A094, Ireland

Email: service-eu@vevor.com Tel: +353874373999

VEVOR TOOL HUB LIMITED

UK REP

Address: 2 Goldstone Close, Brighton and Hove, BN3 7PD, United Kingdom

Email: service-uk@vevor.com Tel: +447795204660



VEVOR

Upgrade · The Home Creator Way

Viehstand

Modell : 51*23 Zoll-B

Modell : 51*23 Zoll-B

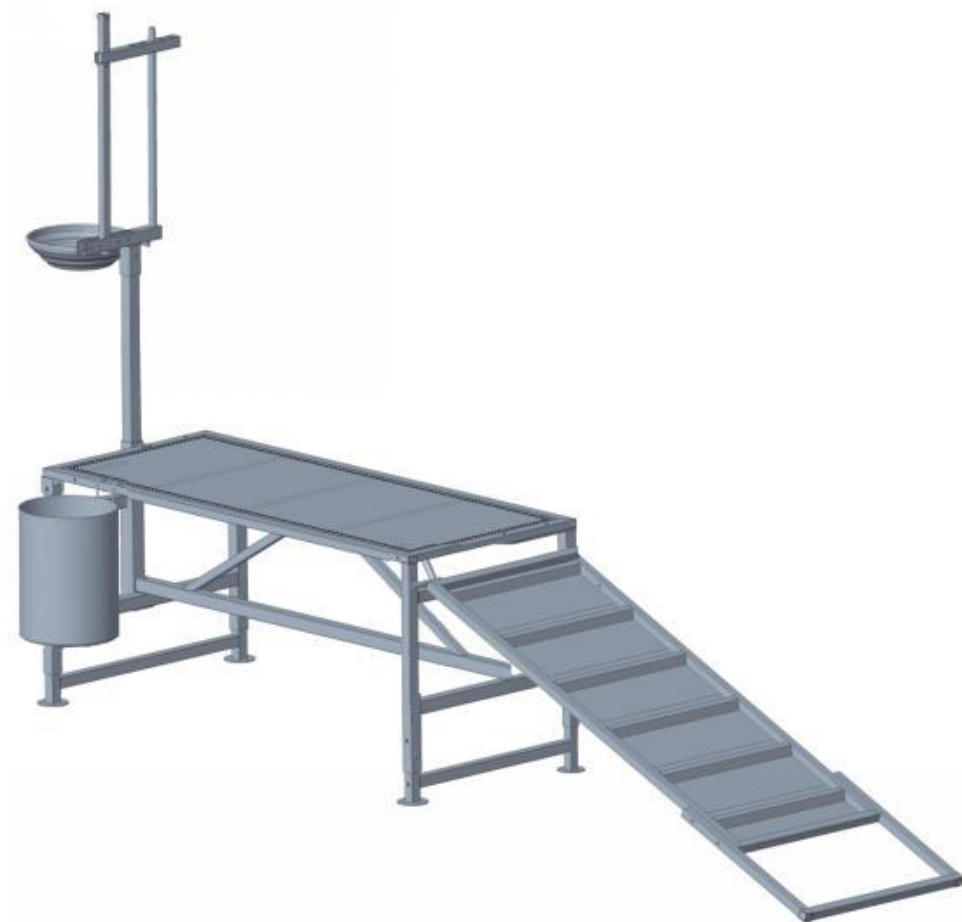

Dies ist die Originalanleitung. Bitte lesen Sie die gesamte Bedienungsanleitung vor der Inbetriebnahme sorgfältig durch. VEVOR behält sich die Auslegung der Bedienungsanleitung vor. Das Aussehen des Produkts kann von dem gelieferten Produkt abweichen. Wir bitten um Verständnis, dass wir Sie nicht erneut über etwaige Technologie- oder

Software-Updates informieren werden .

SAFETY INSTRUCTIONS

WARNUNG:

Lesen Sie diese Hinweise vor der Verwendung dieses Produkts. Andernfalls kann es zu schweren Verletzungen kommen.

Vorsichtsmaßnahmen bei Versammlungen

61. Bitte montieren Sie das Produkt ausschließlich gemäß dieser Anleitung. Eine unsachgemäße Montage kann Gefahren bergen.
62. Tragen Sie während der Montage eine ANSI-geprüfte Schutzbrille und robuste Arbeitshandschuhe.
63. Halten Sie den Montagebereich sauber und gut beleuchtet.
64. Halten Sie Umstehende während der Versammlung vom Versammlungsort fern.
65. Nicht montieren, wenn Sie müde sind oder unter dem Einfluss von Alkohol, Drogen oder Medikamenten stehen.
66. Die Produkteigenschaften gelten nur für ordnungsgemäß und vollständig montierte Produkte.
67. Viehständer auf einer ebenen, harten und glatten Oberfläche, die einen sicheren Halt bietet .
68. Weitere Informationen zu den auf den folgenden Seiten aufgeführten Teilen finden Sie in der Montagezeichnung dieses Handbuchs. Packen Sie alle Teile in einem sauberen Arbeitsbereich aus und trennen Sie sie.
69. Das Produkt entspricht den geltenden Normen und Vorschriften. Die Installation dieses Geräts muss allen anwendbaren Vorschriften entsprechen und es darf nur in gut belüfteten Bereichen betrieben werden. Bitte lesen Sie die Bedienungsanleitung vor der Installation und Inbetriebnahme des Geräts.
70. Dieses Gerät ist nicht für die Verwendung durch Personen (einschließlich Kinder) mit eingeschränkten physischen, sensorischen oder geistigen Fähigkeiten oder mangelnder Erfahrung und Kenntnis bestimmt, es sei denn, sie werden von einer für ihre Sicherheit

verantwortlichen Person beaufsichtigt oder in die Verwendung des Geräts eingewiesen.

71. Dieses Gerät ist für den Einsatz in Haushalten und ähnlichen Anwendungen vorgesehen, wie zum Beispiel:

- Bauernhöfe;

72. Bitte bewahren Sie das Produkt ordnungsgemäß auf. Prüfen Sie es vor Gebrauch auf Beschädigungen. Sollte es Beschädigungen aufweisen, stellen Sie die Verwendung bitte ein.

Vorsicht walten lassen

26. AUF DIESEM GEGENSTAND SITZEN ODER STEHEN NICHT.

27. Dieses Produkt ist kein Spielzeug. Kinder dürfen nicht mit diesem Artikel spielen oder sich in dessen Nähe aufhalten.





28. Die angegebenen Werte dürfen nicht überschritten werden. Tragfähigkeiten.







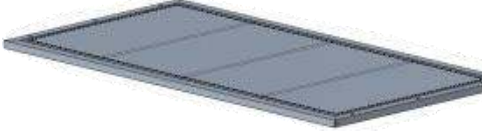



29. Nur bestimmungsgemäß verwenden.





30. Vor jedem Gebrauch prüfen; nicht verwenden, wenn Teile lose oder beschädigt sind.

BEWAHREN SIE DIESES HANDBUCH AUF

PARTS LIST

NEIN .	Teil	Name	Menge.
1		Bewegliches Gestell	1
2		Festes Gestell	1
3		Lange Stange	1
4		Feste Stange	1
5		Tischplatte	1
6		Verstellbares Bein A	2
7		Verstellbares Bein B	1

7-1		Verstellbares Bein B	1
8		Kreisförmiger Reifen	1
9		Becken	1
NEIN	Teil	Name	Menge
10		Werkzeugtasche	1
11		Pleuelstange	1
12		Rampe	1
13		U-förmiger Pfosten	1
A		Schnellverschlussstift	5
B		Kunststoffknopf	7
C		Schrauben M8*45mm	8

D		Nuss M8	16
E		Schnellverschluss tift	2
F		Schrauben M8*60mm	4
G		Schrauben M8*80mm	2

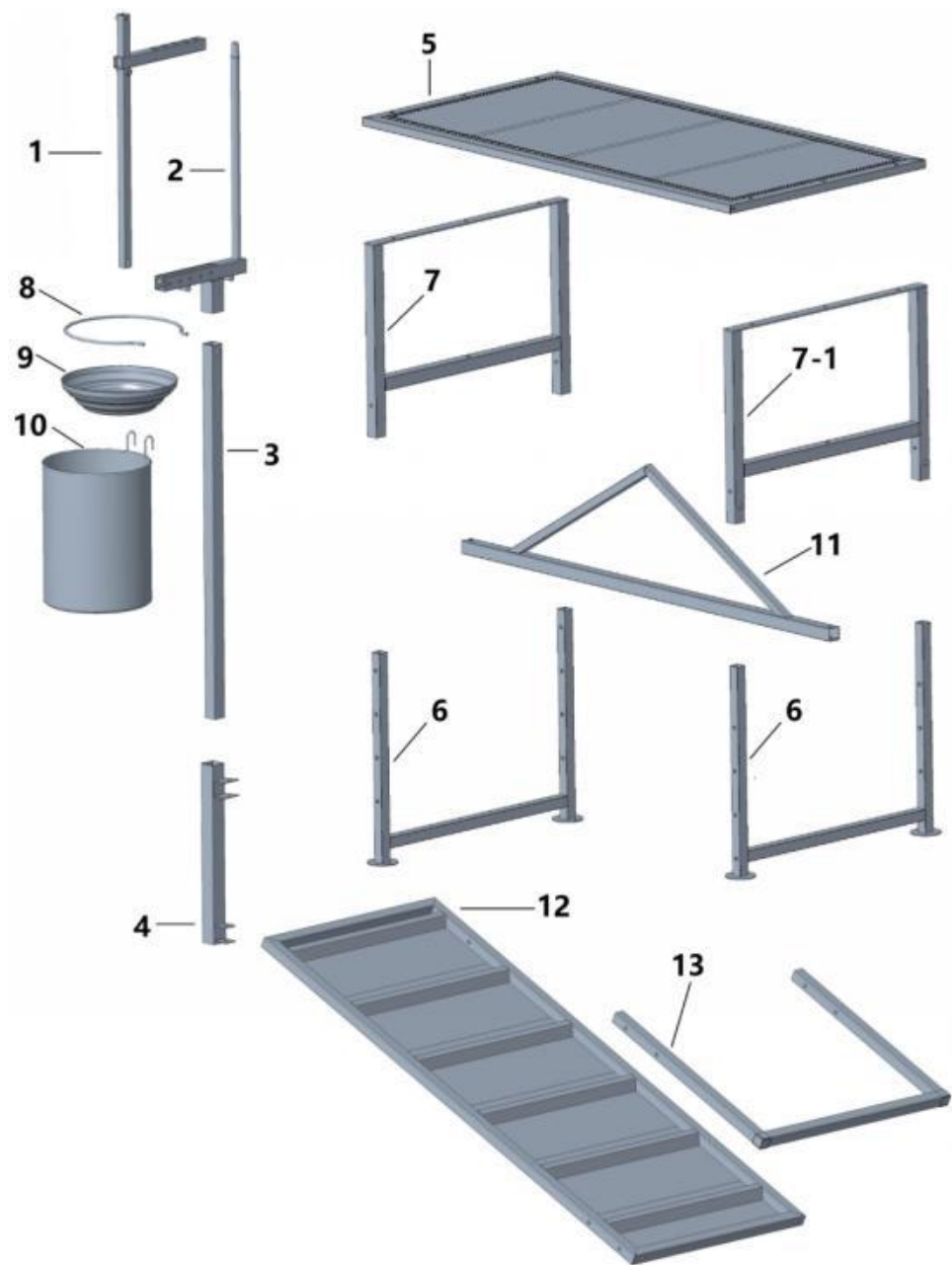

ASSEMBLY STEP

SCHRITT

1

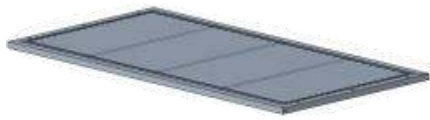

5 x1



7 x1



7-1 x1 M8*35mm



C x5



D x5

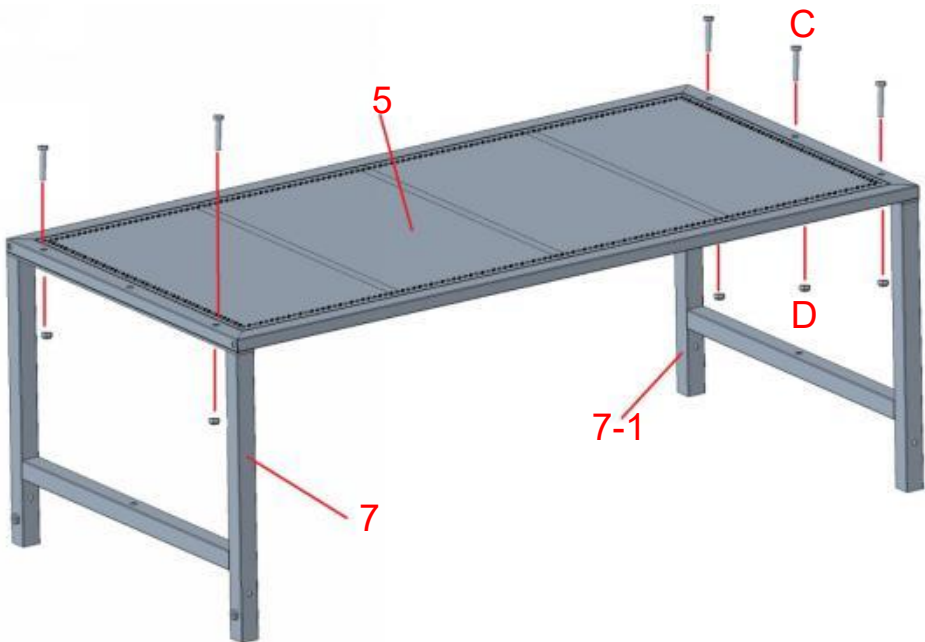

Befestigen Sie das verstellbare Bein B (7) mit Schrauben (C) an der Tischplatte (5) .

SCHRITT

2



4 x 1



11 x 1

M8*35mm



C x 2



D x 4 M8*70mm



F x 2

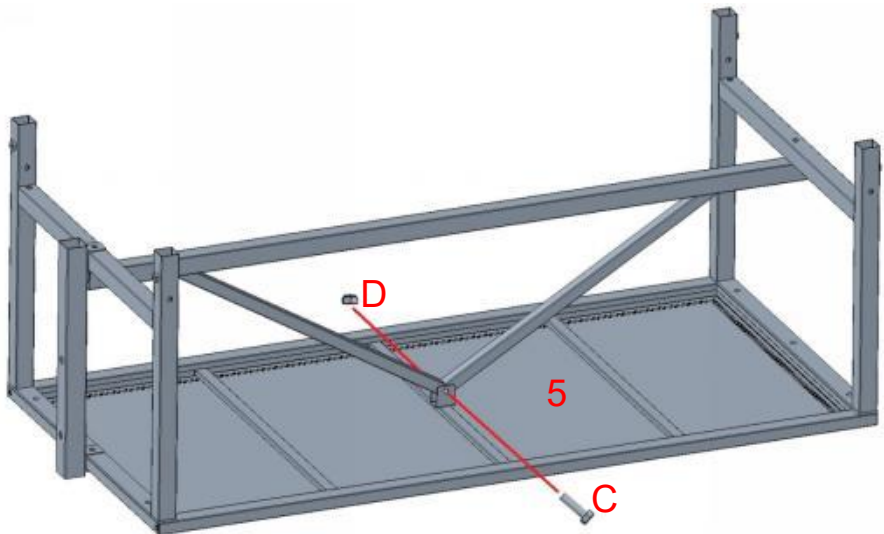
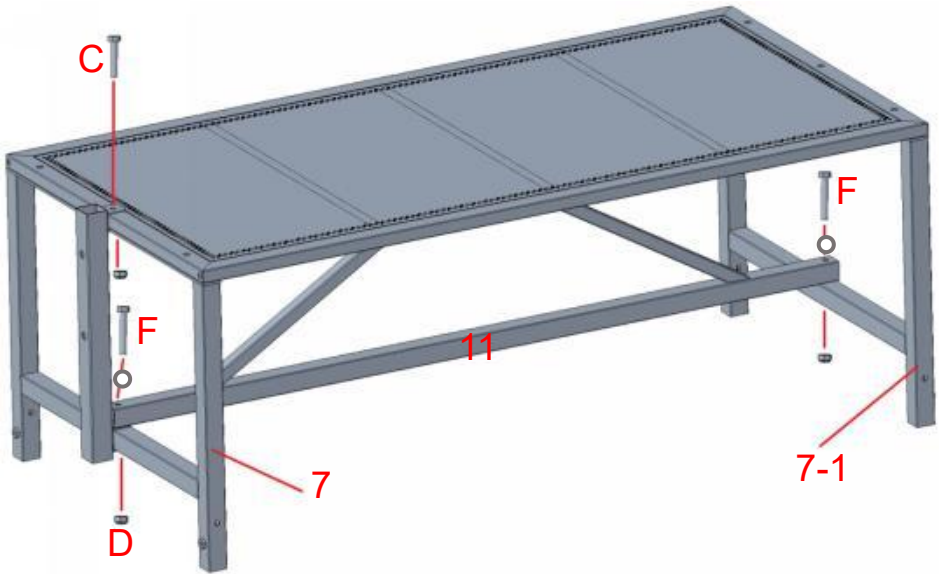

Befestigen Sie die feste Stange (4). und die Verbindungsstange (11) mit der Tischplatte (5) mittels Schrauben (C und H) zu verbinden .

SCHRITT

3

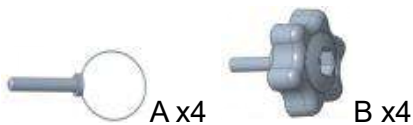

C



12

D

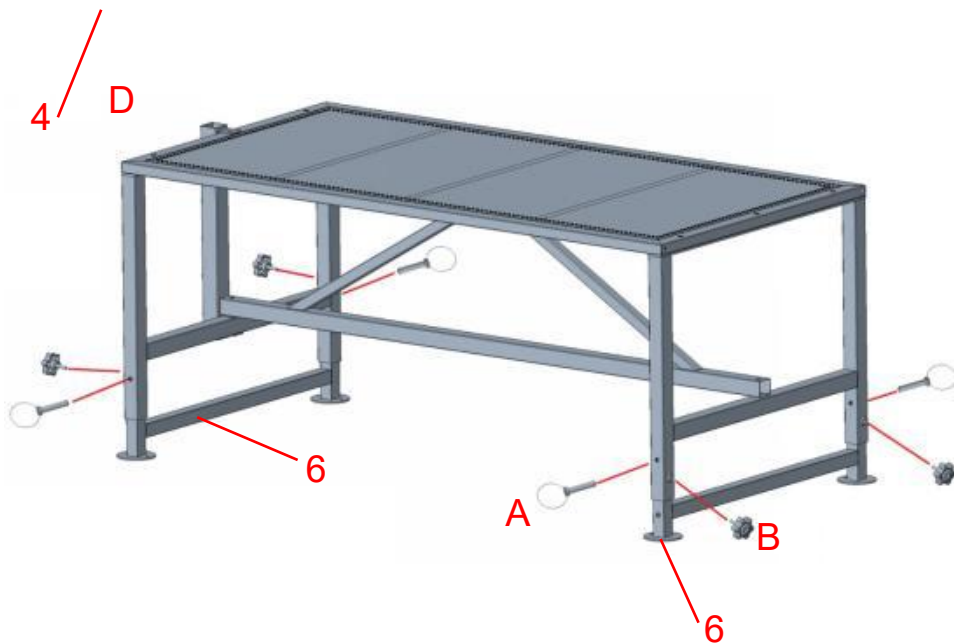

Setzen Sie das verstellbare Bein A (6) in das Stützbein ein und fixieren Sie

es mit dem Stift (A) und dem Kunststoffknopf (B) .

SCHRITT

4

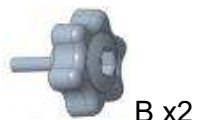

Note the
direction.



3

B

4

Stecken Sie die lange Stange (3) in das feste Rohr (4) und befestigen Sie sie mit dem Kunststoffknopf (B) .

Hinweis: 1. Führen Sie die lange Stange entsprechend der im Diagramm

gezeigten Richtung ein.

2. Die Höhe des gesamten Ziegenkopfgestells kann durch Lösen oder Festziehen des Kunststoffknopfes angepasst werden, indem die lange Stange auf und ab bewegt wird.

SCHRITT

5-1



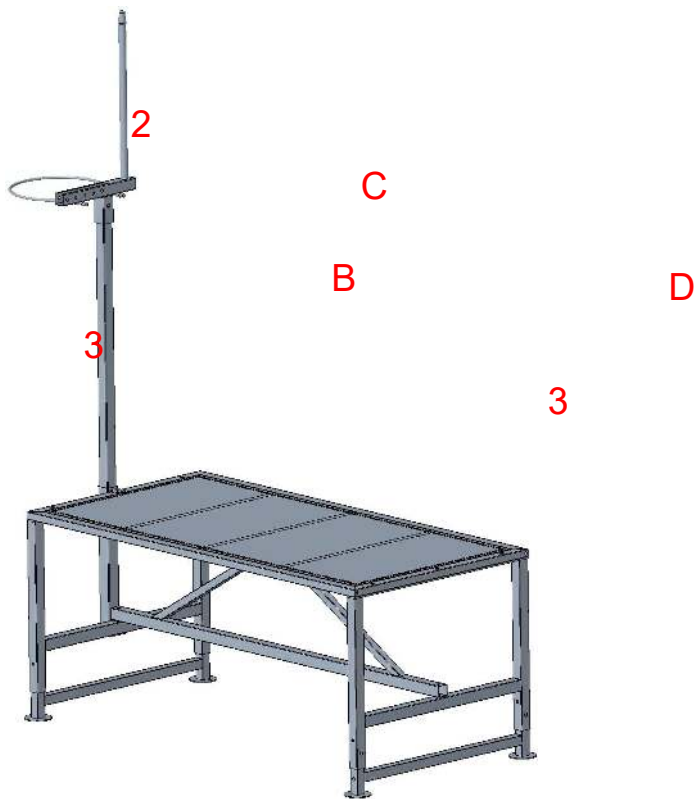

Halterung für den Ziegenkopf (2) mit der Schraube (C) und dem Kunststoffknopf (B) an der langen Stange (3) .

SCHRITT

5-2



1 x1



A x1

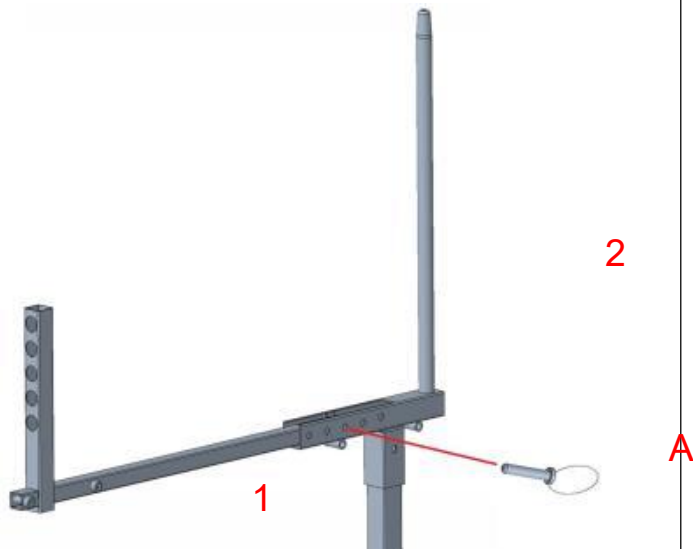

movable rack

Setzen Sie (1) in die Halterung (2) des Ziegenkopfes ein und befestigen Sie es mit einem Stift (A) .

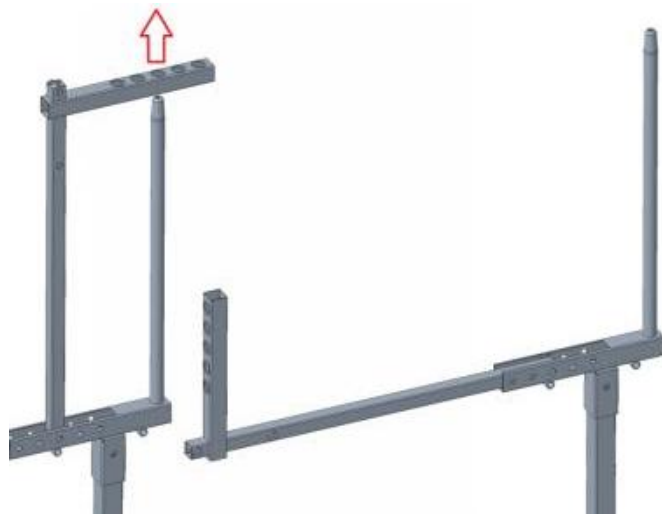

Heben Sie die bewegliche Querstange des Gestells an, richten Sie sie an dem runden Rohr des festen Gestells aus und senken Sie sie dann in ihre Position ab.

SCHRITT



8 x1 D x2

6

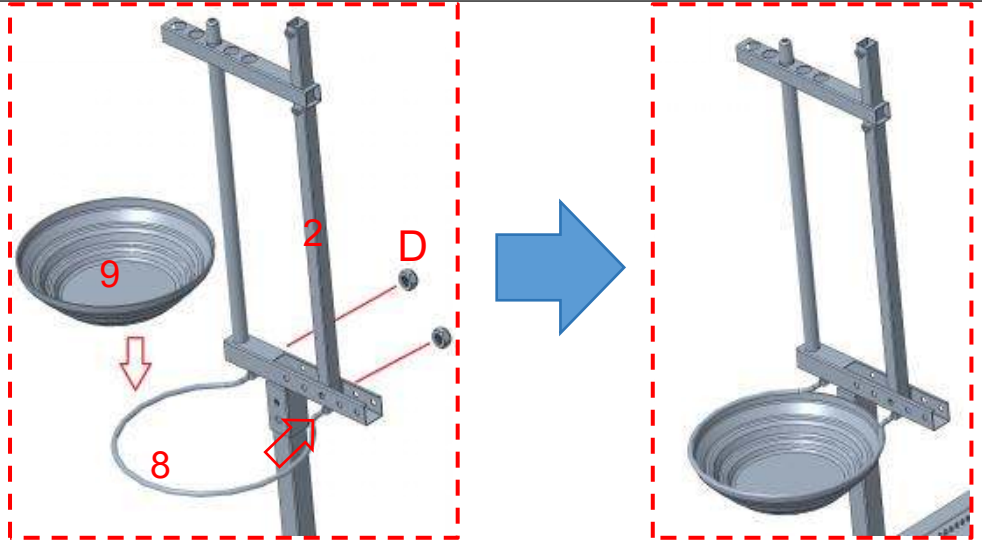
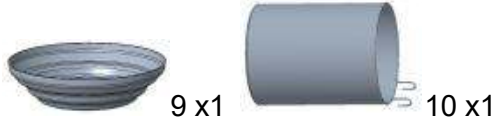

1. Den runden Bügel (8) durch die Halterung des Ziegenkopfes (2) führen und mit Schrauben (D) festziehen .
2. Stellen Sie das Becken (9) auf den runden Reifen zum Aufbewahren von Wasser oder Futter.

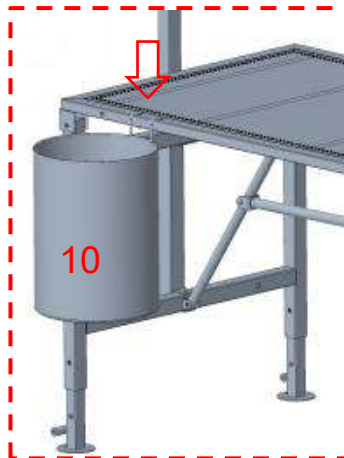

3. Hängen Sie die Werkzeugtasche (10) an die Plattform. Die Plattform

verfügt über 4 Positionen zur flexiblen Anpassung an die Nutzungsgewohnheiten.

SCHRITT

7

M8*70mm



F x4



D x4



14 x1



15 x1

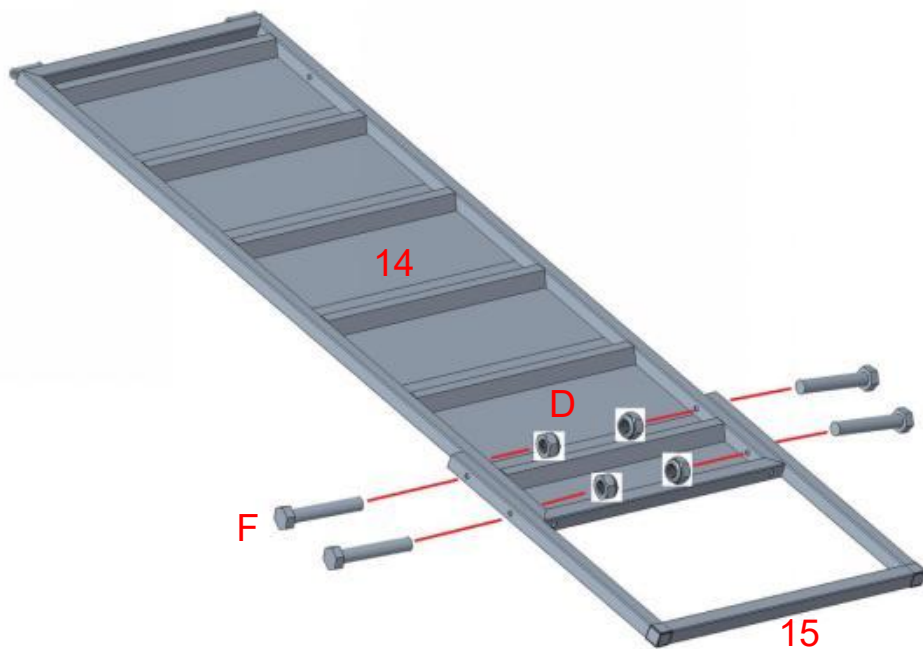

Befestigen Sie die U-förmige Stange (15) mit Schrauben (F) an der Rampe

(14) .

SCHRITT

8

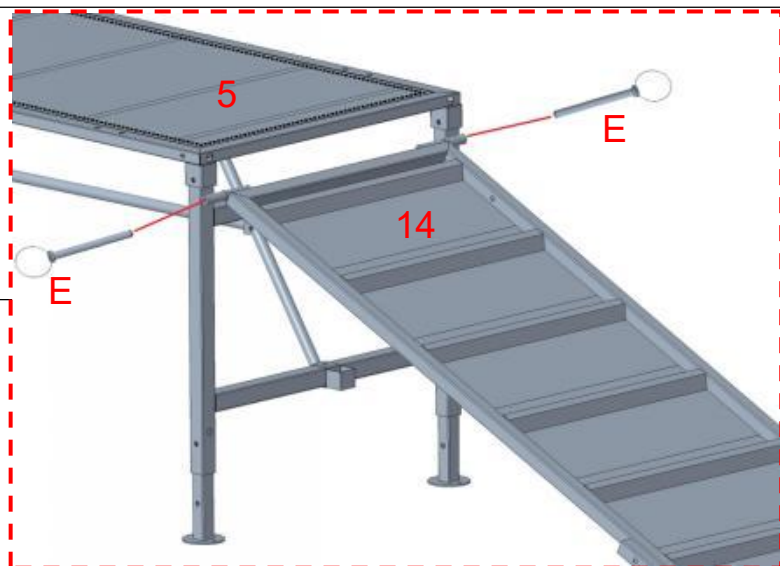

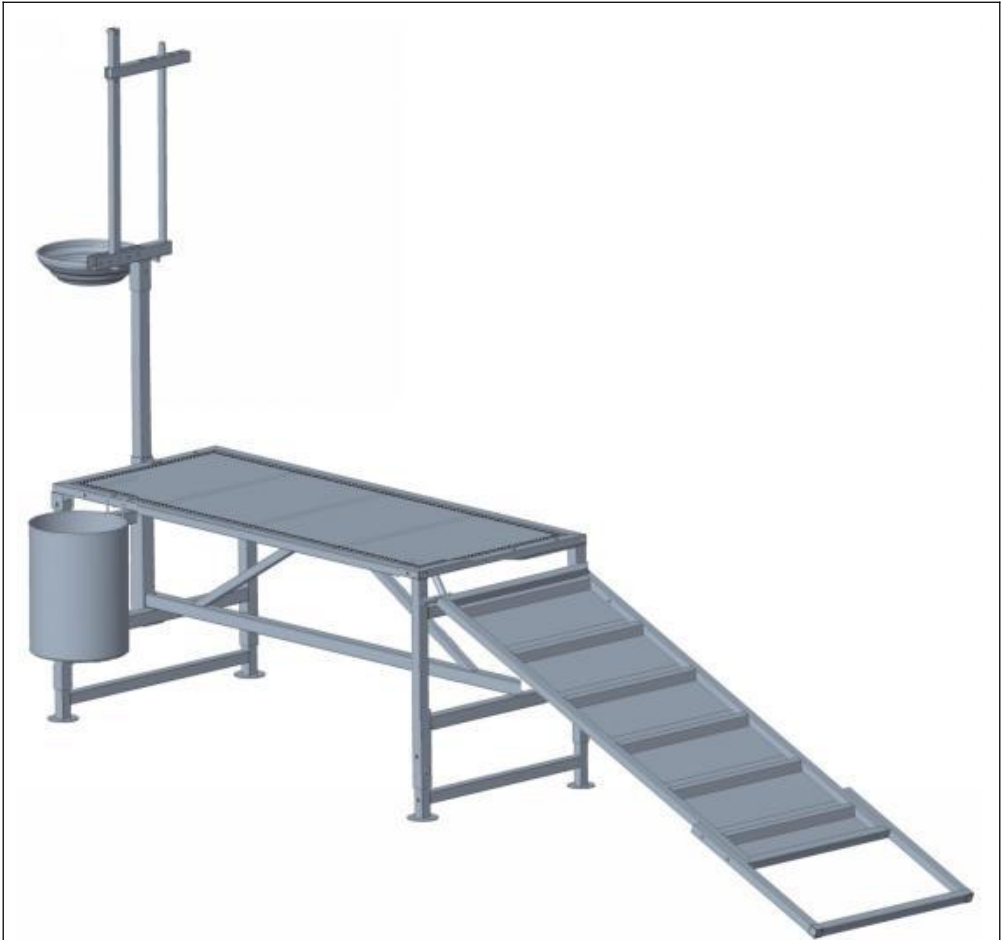

Sichern Sie die Rampe (14) zur Tischplatte (5) mit Stiften (E) .

Anleitung zur Einstellung der Kopfbandbreite:



16. The fixed rack and movable rack are both equipped with 5 adjustment positions. The smaller the number, the narrower the spacing.

17. The upper and lower positions must be aligned to maintain a vertical state.

18. If you are unsure which position to choose, start with the middle position. If the goat's neck cannot be securely fixed, use a position with a smaller spacing.

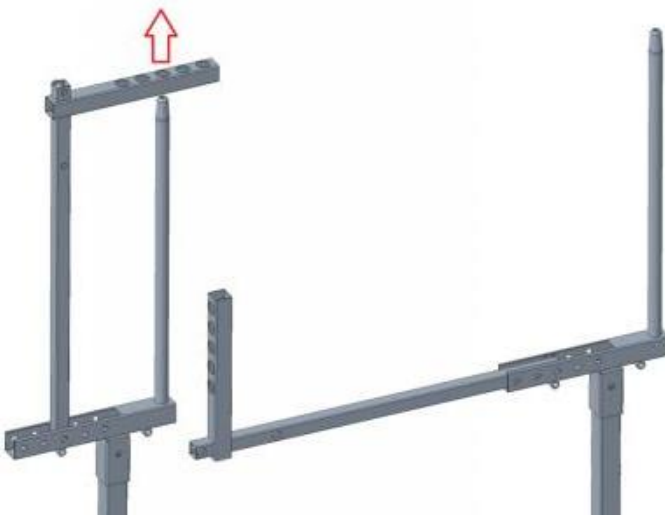

Heben Sie die bewegliche Querstange des Gestells an, richten Sie sie an dem runden Rohr des festen Gestells aus und senken Sie sie dann in ihre Position ab.

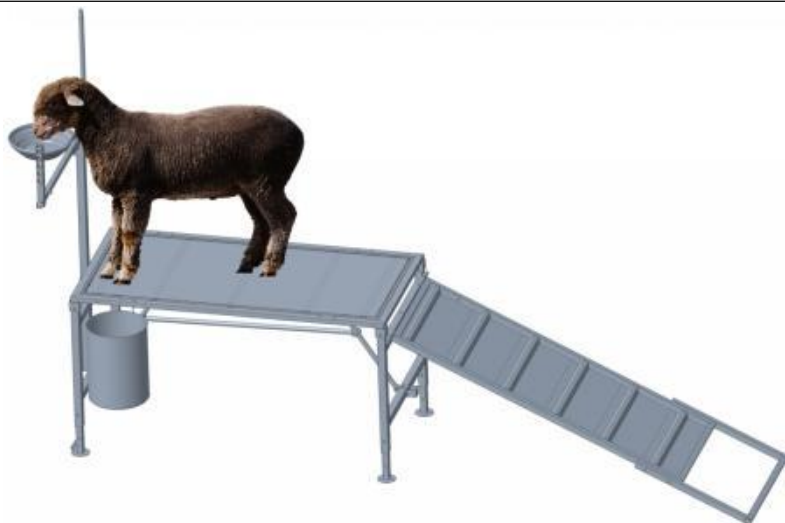

Öffnen Sie die Halterung und führen Sie die Ziege zum festen Gestell .
Hinweis: Stellen Sie die Höhe des festen Gestells so ein, dass der Hals der Ziege auf gleicher Höhe mit der unteren Querstange der Halterung ist. In dieser Position kann die Ziege ihren Kopf zum Trinken oder Fressen senken, ohne dass er beim Anheben des Kopfes die obere Querstange berührt und dadurch herausfällt.



Heben Sie die bewegliche Querstange des Gestells an, richten Sie sie an dem runden Rohr des festen Gestells aus und senken Sie sie dann in ihre Position ab.

PRODUCT PARAMETER

Modell	51*23 Zoll-B
Sichere Ladegewicht	600 Pfund/272 kg
Farbe	Schwarz
Desktopgröße	51*23 Zoll (1295*584 mm)

Manufacturer: Shanghai Sishun Technology Co., Ltd
Address: 4th Floor, Building 2, No. 599 Wan Zhen Road, Zhenxin Xincun Subdistrict, Jiading District, Shanghai, 201800 China
E-mail: support@vevor.com

Imported to AUS: SIHAO PTY LTD. 1 ROKEVA STREET EASTWOOD NSW 2122 Australia

Imported to USA: Sarven Technology Ltd. Suite 250, 9166 Anaheim Place, Rancho Cucamonga, CA 91730

VEVOR SUPER TOOLS LIMITED

EC REP

Address: Office 403, Nesta Business Centre, 4-5 Burton Hall Rd, Sandyford, Dublin 18, D18 A094, Ireland

Email: service-eu@vevor.com Tel: +353874373999

VEVOR TOOL HUB LIMITED

UK REP

Address: 2 Goldstone Close, Brighton and Hove, BN3 7PD, United Kingdom

Email: service-uk@vevor.com Tel: +447795204660



VEVOR

Upgrade · The Home Creator Way

Stanowisko hodowlane

Model : 51*23 cale-B

Model : 51*23 cale-B

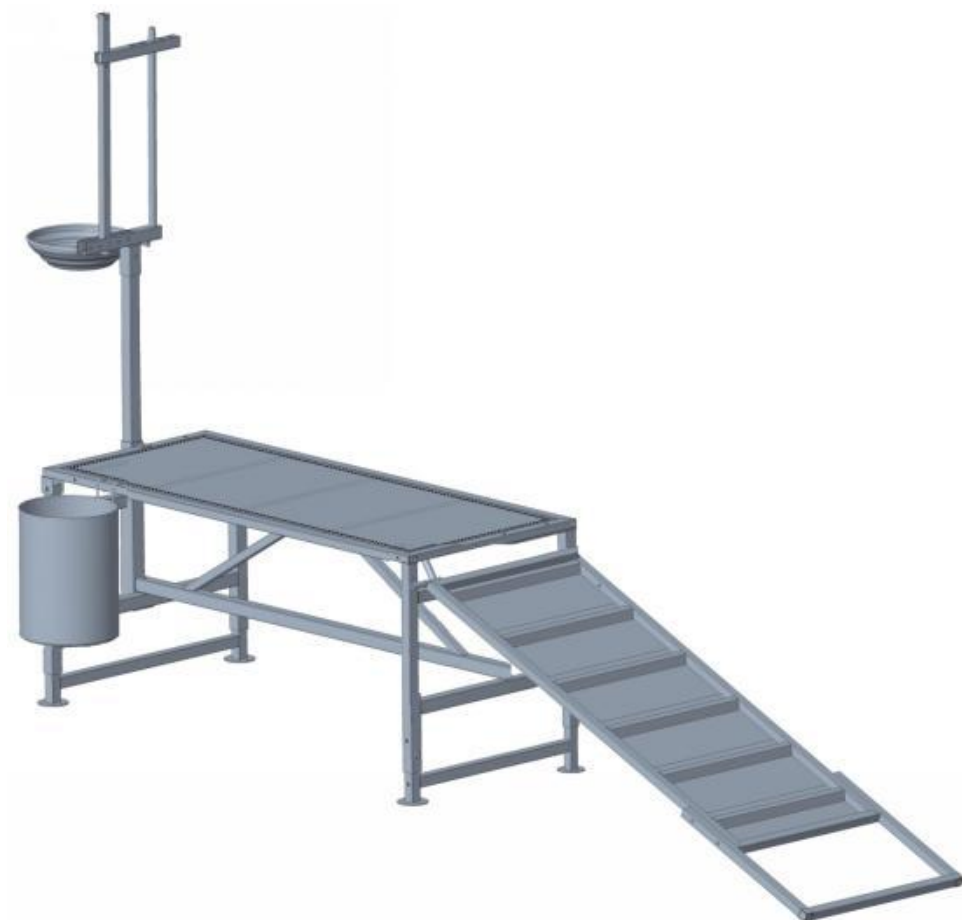

To jest oryginalna instrukcja obsługi. Przed użyciem prosimy o dokładne zapoznanie się z treścią instrukcji. Firma VEVOR zastrzega sobie prawo do jednoznacznej interpretacji niniejszej instrukcji obsługi. Wygląd produktu zależy od stanu, w jakim go otrzymali Państwo. Prosimy o wyrozumiałość, ale nie będziemy Państwa ponownie informować o

aktualizacjach technologicznych lub oprogramowania naszego produktu.

SAFETY INSTRUCTIONS

OSTRZEŻENIE:

Przeczytaj ten materiał przed użyciem produktu. Nieprzestrzeganie tego zalecenia może spowodować poważne obrażenia.

Środki ostrożności podczas montażu

73. Montaż należy wykonywać wyłącznie zgodnie z niniejszą instrukcją. Nieprawidłowy montaż może stwarzać zagrożenie.
74. Podczas montażu należy nosić okulary ochronne zatwierdzone przez ANSI oraz wytrzymałe rękawice robocze.
75. Utrzymuj miejsce zgromadzenia w czystości i dobrym oświetleniu.
76. Nie dopuszczać osób postronnych na teren montażu w trakcie jego trwania.
77. Nie przychodź na zgromadzenie, jeśli jesteś zmęczony lub pod wpływem alkoholu, narkotyków lub leków.
78. Możliwości produktu odnoszą się wyłącznie do produktów prawidłowo i całkowicie zmontowanych.
79. Montaż należy wykonać na płaskiej, równej, twardej i gładkiej powierzchni, która będzie w stanie bezpiecznie utrzymać stojak na zwierzęta gospodarskie.
80. Aby uzyskać dodatkowe informacje dotyczące części wymienionych na kolejnych stronach, zapoznaj się ze schematem montażu w niniejszej instrukcji. Rozpakuj i oddziel wszystkie części w czystym miejscu pracy.
81. Produkt jest zgodny z odpowiednimi normami i przepisami. Instalacja tego urządzenia musi być zgodna ze wszystkimi obowiązującymi przepisami i powinno być ono użytkowane wyłącznie w dobrze wentylowanych pomieszczeniach. Przed instalacją i użytkowaniem urządzenia należy zapoznać się z instrukcją obsługi.
82. Urządzenie to nie jest przeznaczone do użytku przez osoby (w tym dzieci) o ograniczonej sprawności fizycznej, sensorycznej lub umysłowej, a także osoby nieposiadające odpowiedniego

doświadczenia lub wiedzy, chyba że znajdują się pod nadzorem osoby odpowiedzialnej za ich bezpieczeństwo lub otrzymały od niej instrukcje dotyczące korzystania z urządzenia.

83. Urządzenie to przeznaczone jest do stosowania w gospodarstwach domowych i podobnych zastosowaniach, takich jak:
- gospodarstwa wiejskie;
84. Prosimy o prawidłowe przechowywanie produktu. Przed użyciem należy sprawdzić, czy produkt nie wykazuje oznak nieprawidłowości. W przypadku stwierdzenia nieprawidłowości, należy zaprzestać jego używania.











Zachowaj środki ostrożności



31. NIE WOLNO SIEDZIEĆ ANI STAWAĆ NA TYM PRZEDMIOCIE.
32. Ten produkt nie jest zabawką. Nie pozwalaj dzieciom bawić się nim ani przebywać w jego pobliżu.
33. Nie przekraczać określonej wartości nośności.
34. Stosować wyłącznie zgodnie z przeznaczeniem.
35. Przed każdym użyciem należy przeprowadzić kontrolę. Nie używać produktu, jeśli części są luźne lub uszkodzone.

ZAPISZ TĘ INSTRUKCJĘ

PARTS LIST

NIE.	Część	Nazwa	Ilość
1		Ruchomy regał	1
2		Stały stojak	1
3		Długi kij	1
4		Pręt stały	1
5		Blat stołu	1
6		Regulowana noga A	2
7		Regulowana noga B	1

7-1		Regulowana noga B	1
8		Obręcz okrągła	1
9		Basen	1
NIE.	Część	Nazwa	Ilość
10		Torba narzędziowa	1
11		Korbowód	1
12		Rampa	1
13		Słup w kształcie litery U	1
A		Szybkozłączka	5
B		Plastikowa gałka	7
C		Śruba M8*45mm	8
D		Nakrętka M8	16

mi		Szybkozłączka	2
F		Śruba M8*60mm	4
G		Śruba M8*80mm	2

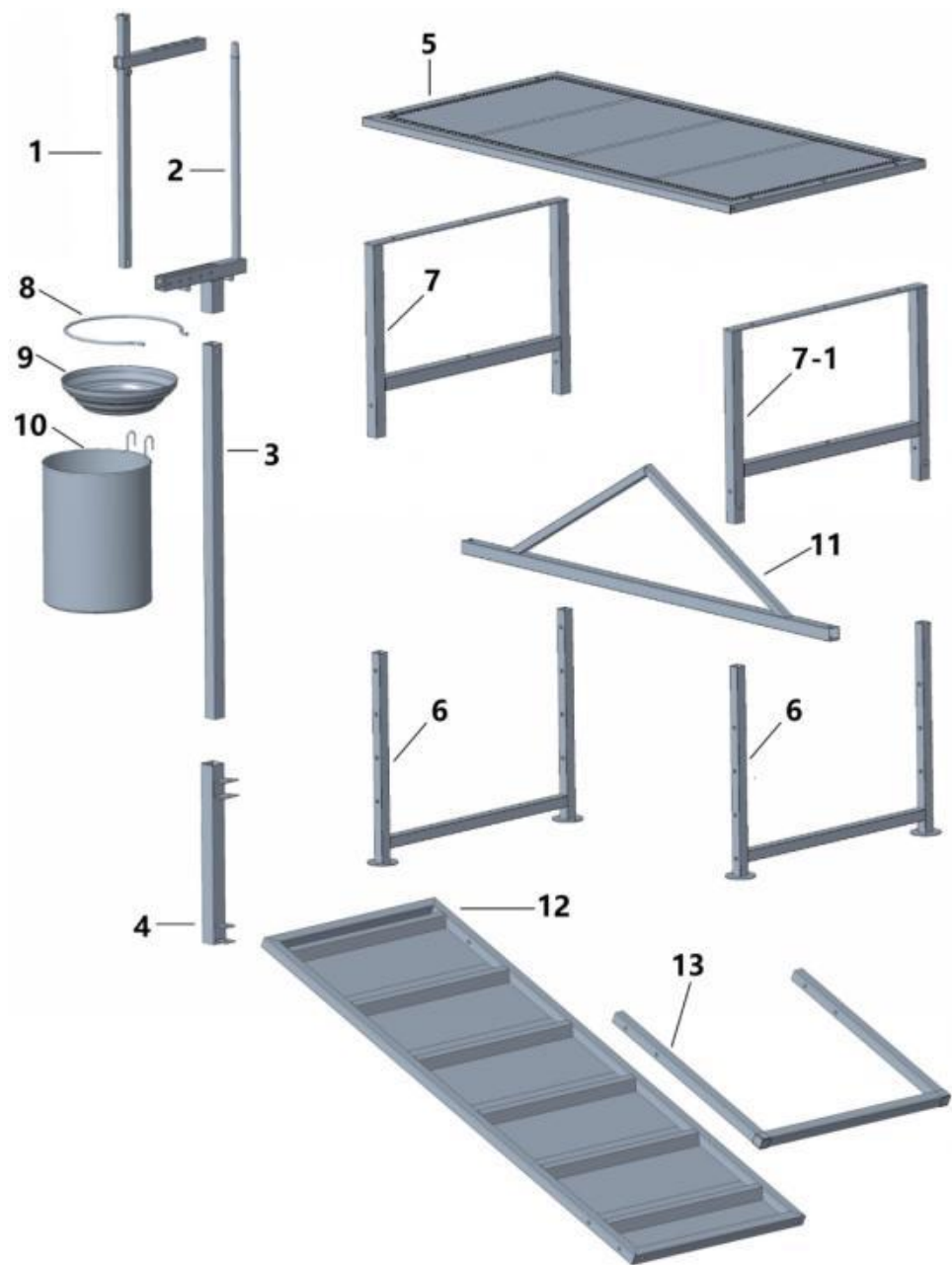

ASSEMBLY STEP

KROK 1

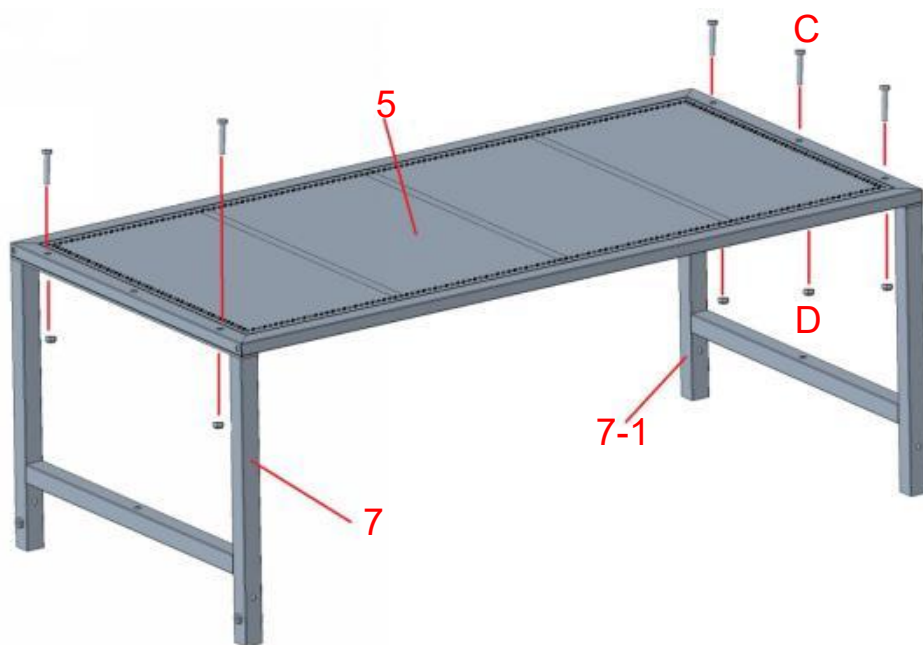

Przymocuj regulowaną nogę B (7) do blatu stołu (5) za pomocą śrub (C) .

KROK 2



4 x1



11 X1

M8*35mm



C x2



D x4 M8*70mm



F x2

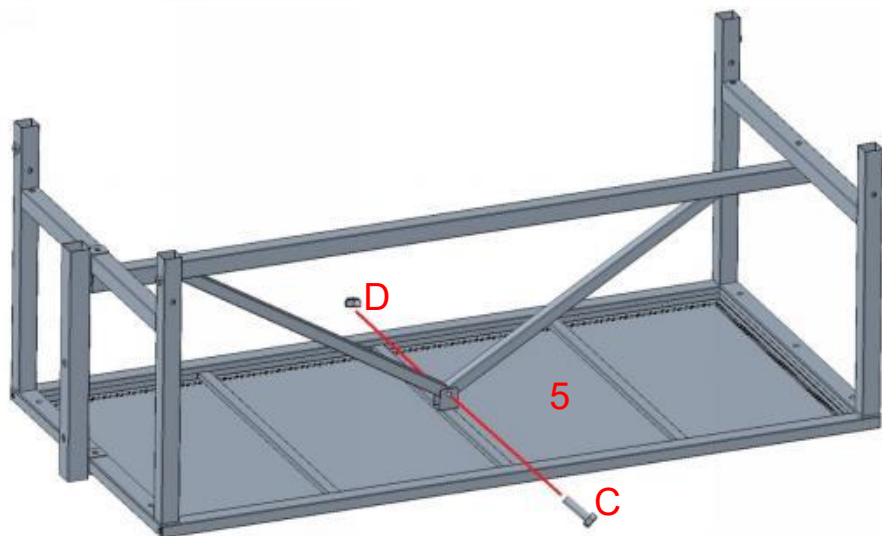
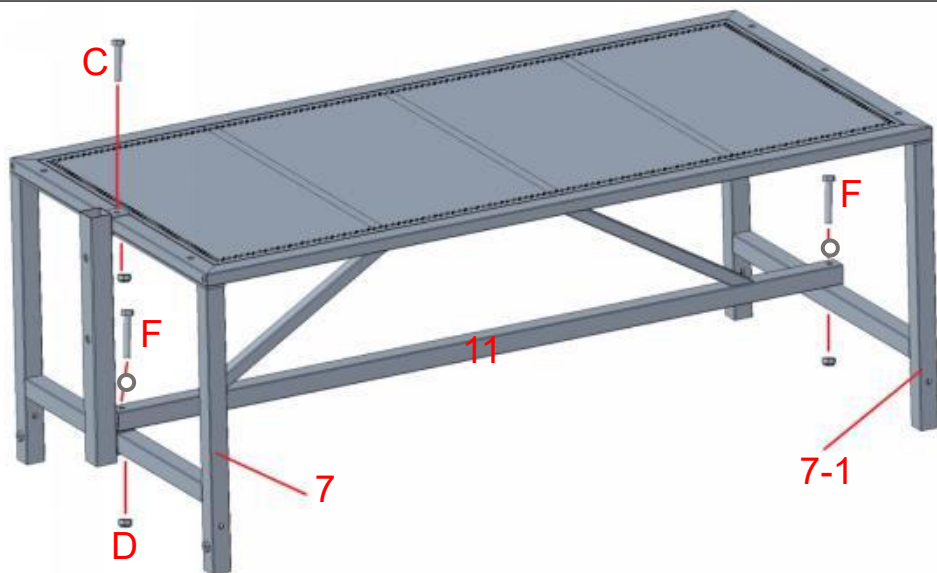

Zabezpiecz pręt stały (4) i pręt łączący (11) do blatu stołu (5) za pomocą śrub (C i H) .

KROK 3

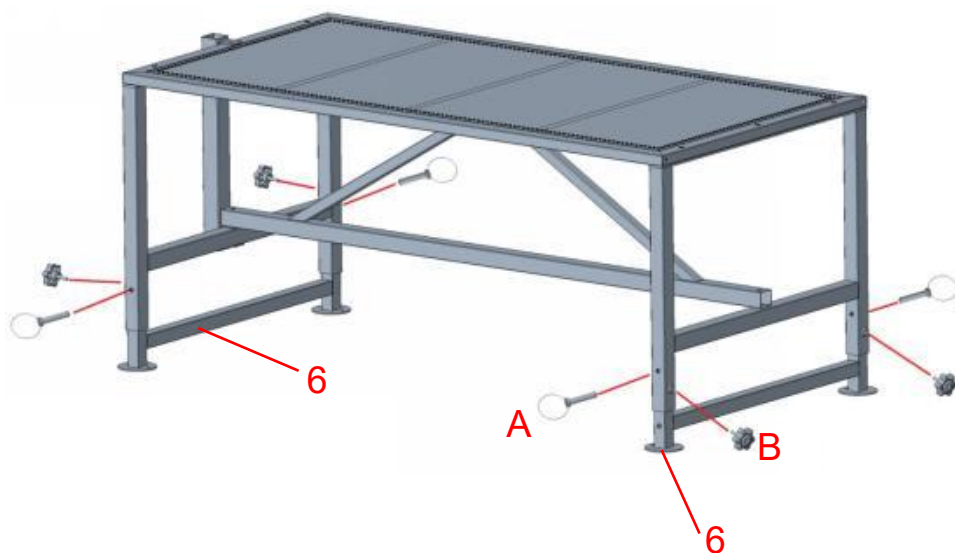
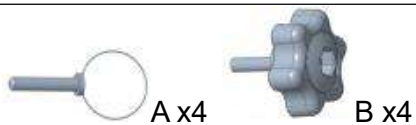

Włóż regulowaną nogę A (6) do nogi podporowej i zamocuj ją za pomocą sworznia (A) i plastikowego pokrętła (B) .

KROK 4

3 x1

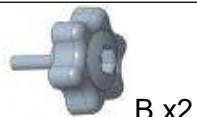

Note the
direction.

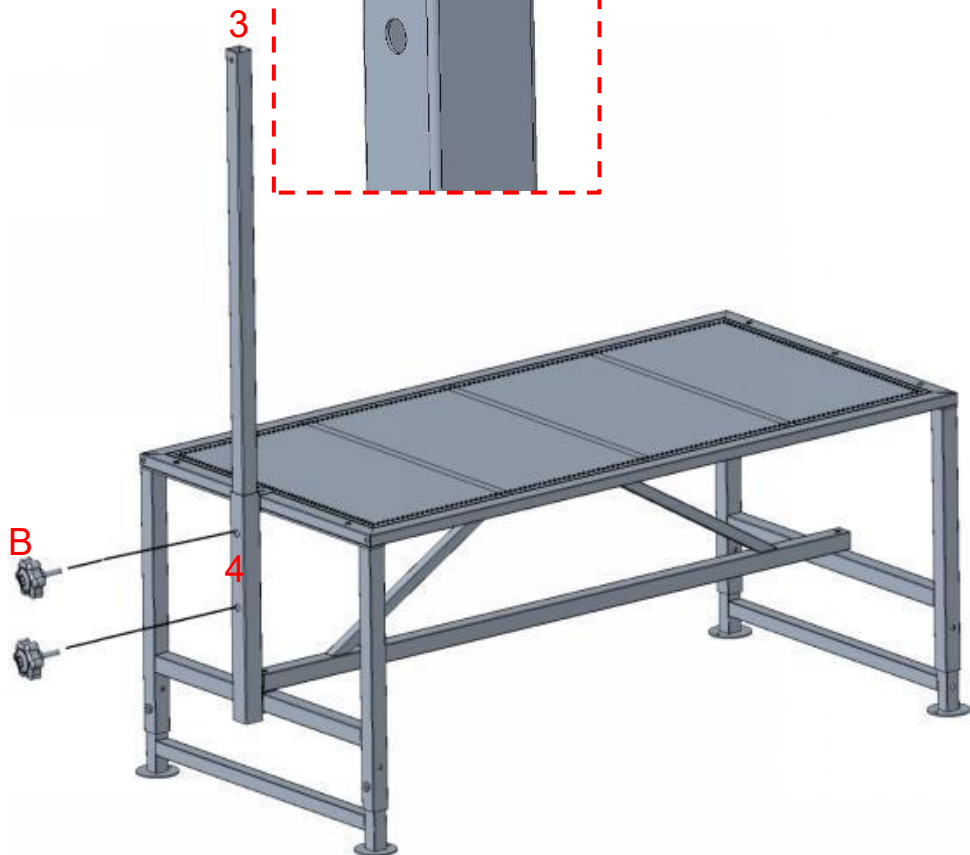

Włóż długi drążek (3) do rury stałej (4) i zabezpiecz go plastikowym pokrętkiem (B) .

Uwaga: 1. Włóż długi drążek zgodnie z kierunkiem pokazanym na schemacie.

2. Wysokość całego stojaka na głowę kozy można regulować poprzez luzowanie lub dokręcanie plastikowego pokrętła, co pozwala na

przesuwanie długiego drążka w górę i w dół.

KROK

5-1

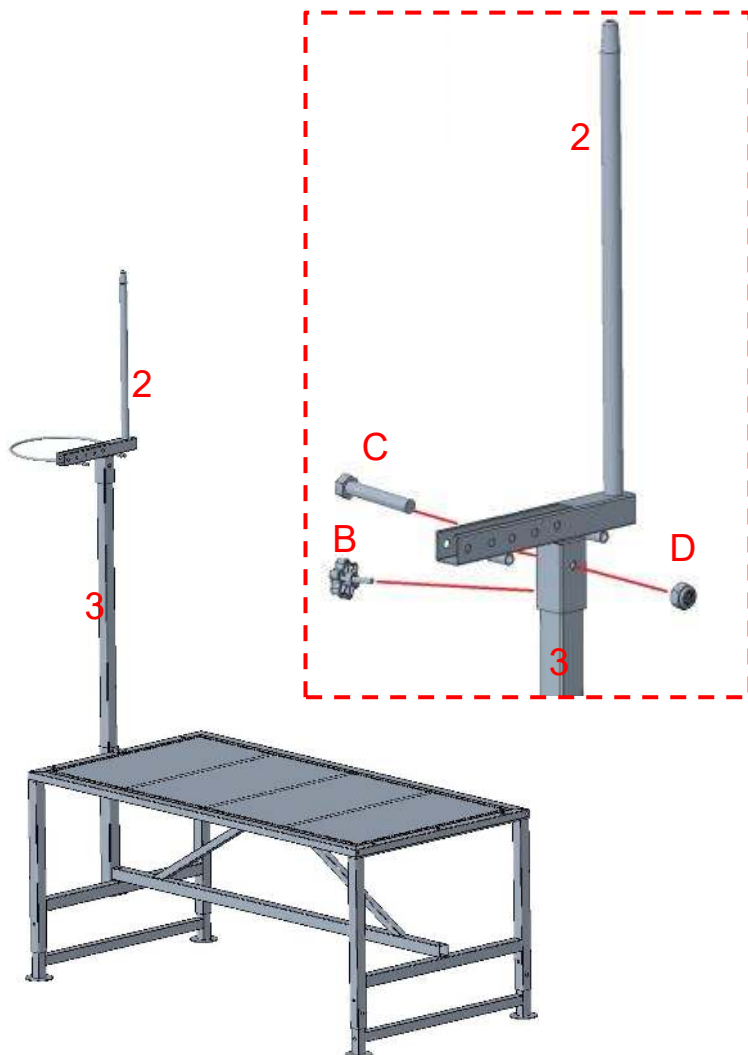

uchwyt montażowy głowy kozy (2) do długiego słupa (3) za pomocą śruby (C) i plastikowego pokrętła (B) .

KROK

5-2



1 x1



A x1

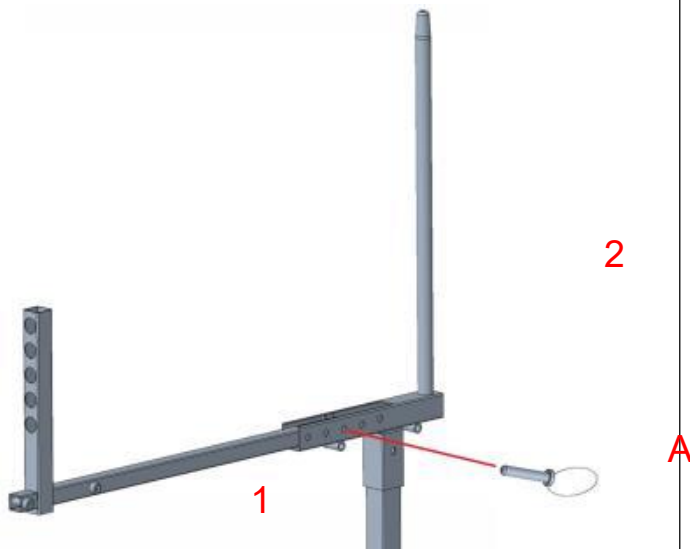

movable rack

Włóż (1) do uchwyty montażowego głowy kozy (2) i zabezpiecz go kołkiem (A) .

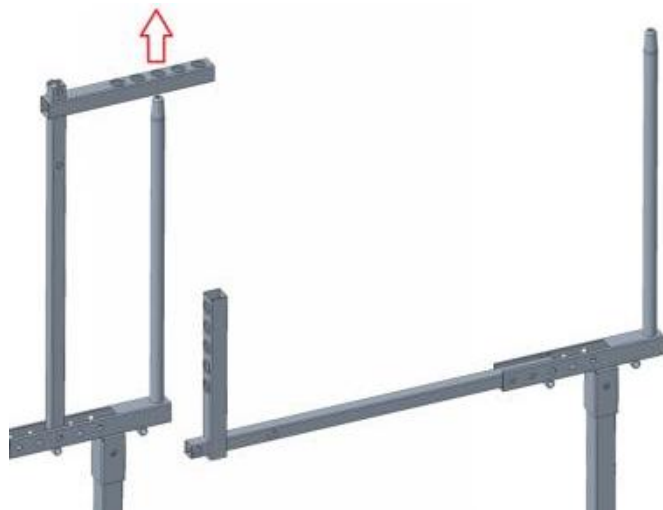

Podnieś ruchomą poprzeczkę zębataki , wyrównaj ją z okrągłą rurą stałej zębataki , a następnie opuść ją na miejsce.

KROK 6

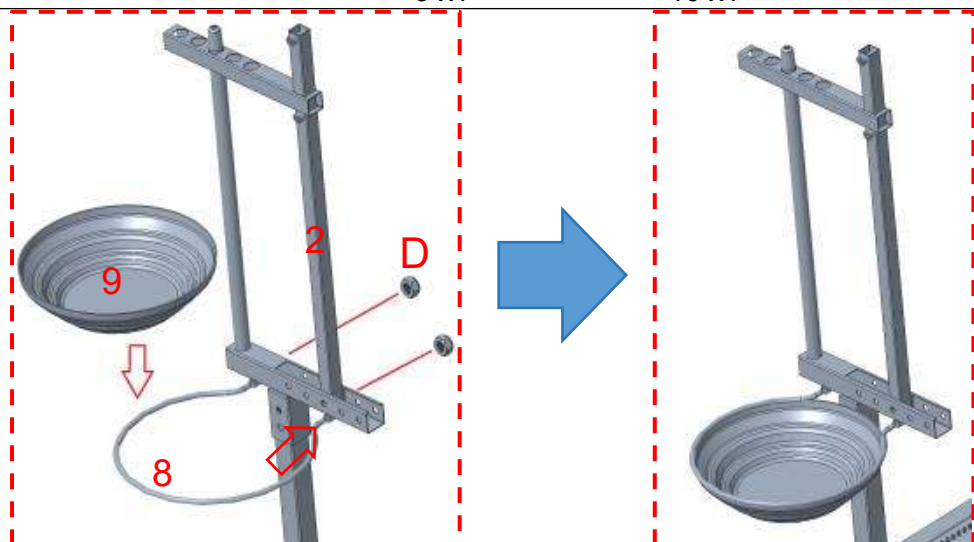

1. Przelóż okrągłą obręcz (8) przez uchwyt montażowy z głową kozy (2) i

dokręć ją śrubami (D) .

2. Umieść miskę (9) na okrągłej obręczy służącej do przechowywania wody lub paszy.

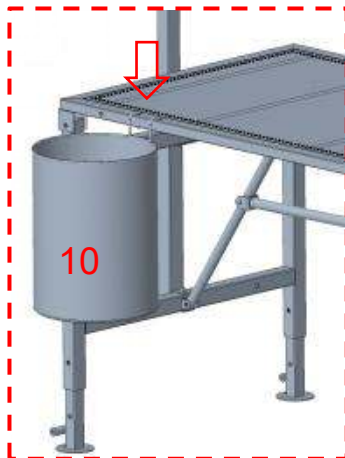

3. Zawieś torbę z narzędziami (10) na platformie. Platforma jest wyposażona w 4 pozycje, co pozwala na elastyczne dopasowanie do nawyków użytkownika.

KROK 7

M8*70mm



F x4



D x4



14 x1



15 x1

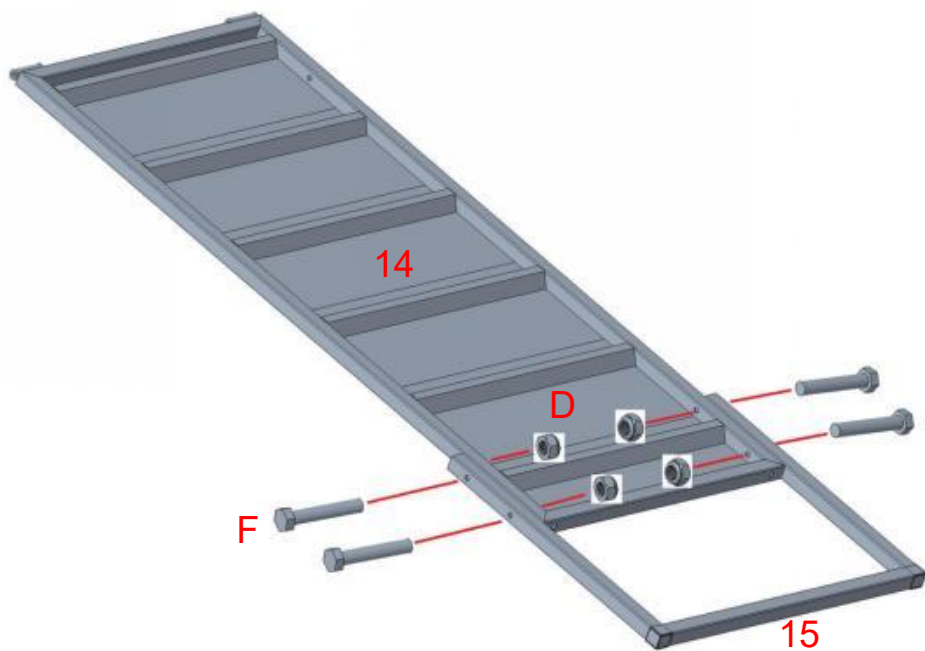

Przymocuj słupek w kształcie litery U (15) do rampy (14) za pomocą śrub (F).

KROK 8

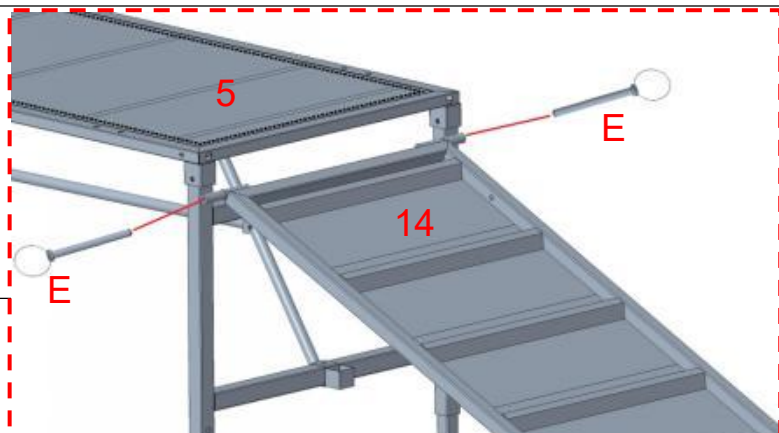
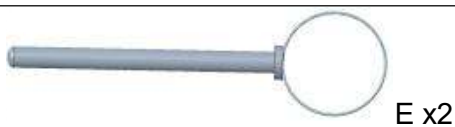

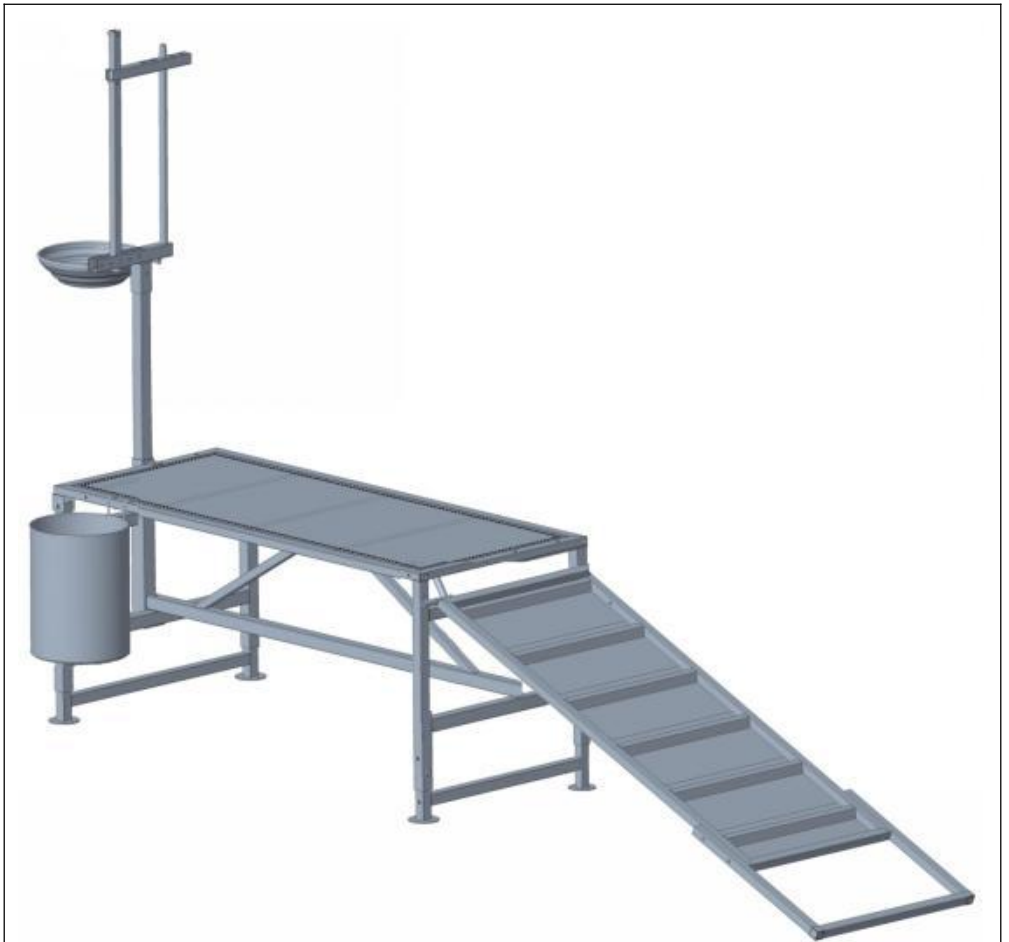

Zabezpiecz rampę (14) do blatu stołu (5) za pomocą kołków (E) .

Instrukcje dotyczące regulacji szerokości opaski:



19. The fixed rack and movable rack are both equipped with 5 adjustment positions. The smaller the number, the narrower the spacing.
 20. The upper and lower positions must be aligned to maintain a vertical state.
 21. If you are unsure which position to choose, start with the middle position. If the goat's neck cannot be securely fixed, use a position with a smaller spacing.

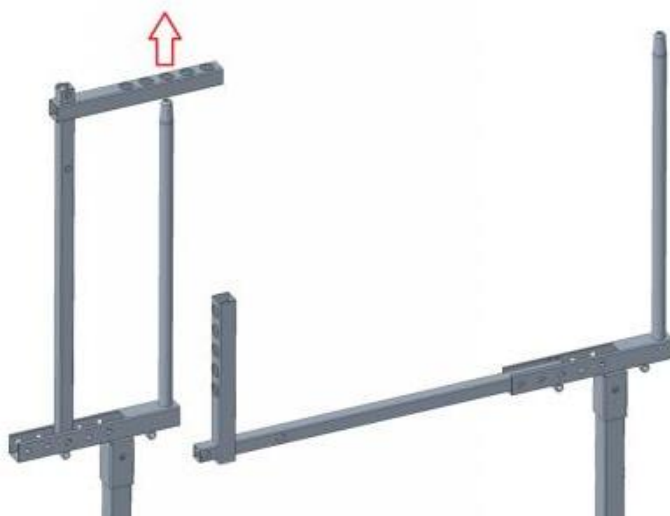

Podnieś ruchomą poprzeczkę zębataki , wyrównaj ją z okrągłą rurą stałej zębataki , a następnie opuść ją na miejsce.

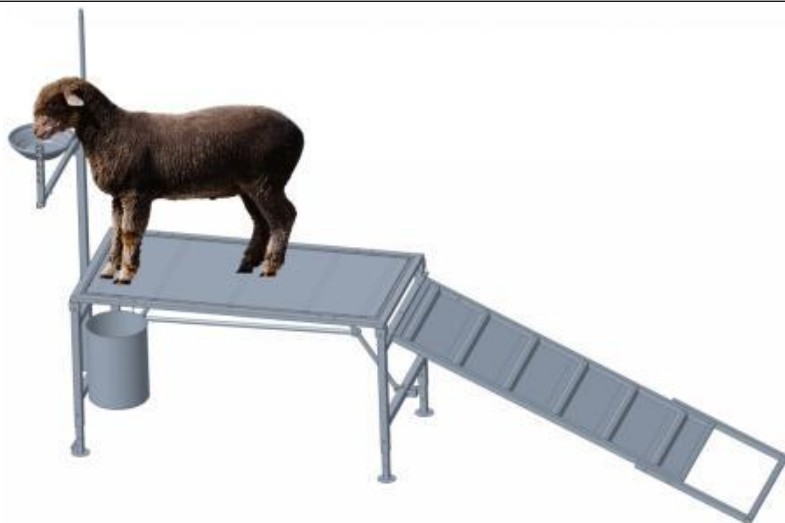

Otwórz uchwyt i poprowadź kozę do stałego stojaka .

Uwaga: Wyreguluj wysokość stałego stojaka tak, aby dolna część szyi kozy znajdowała się na poziomie dolnej poprzeczki wspornika. Taka pozycja pozwala kozie opuścić głowę do picia lub jedzenia i nie dotknie górnej poprzeczki, co mogłoby spowodować jej przesunięcie podczas podnoszenia głowy.



Podnieś ruchomą poprzeczkę zębataki , wyrównaj ją z okrągłą rurą stałej zębataki , a następnie opuść ją na miejsce.

PRODUCT PARAMETER

Model	51*23 cale-B
Bezpieczna waga załadunku	600 funtów/272 kg
Kolor	Czarny
Rozmiar pulpitu	51*23 cale (1295*584 mm)

Manufacturer: Shanghai Sishun Technology Co., Ltd
Address: 4th Floor, Building 2, No. 599 Wan Zhen Road, Zhenxin Xincun Subdistrict, Jiading District, Shanghai, 201800 China
E-mail: support@vevor.com

Imported to AUS: SIHAO PTY LTD. 1 ROKEVA STREET EASTWOOD NSW 2122 Australia

Imported to USA: Sarven Technology Ltd. Suite 250, 9166 Anaheim Place, Rancho Cucamonga, CA 91730

VEVOR SUPER TOOLS LIMITED

EC REP

Address: Office 403, NESTA Business Centre, 4-5 Burton Hall Rd, Sandyford, Dublin 18, D18 A094, Ireland

Email: service-eu@vevor.com Tel: +353874373999

VEVOR TOOL HUB LIMITED

UK REP

Address: 2 Goldstone Close, Brighton and Hove, BN3 7PD, United Kingdom

Email: service-uk@vevor.com Tel: +447795204660



VEVOR

Upgrade · The Home Creator Way

Stalla per il bestiame

Modello : 51*23 pollici-B

Modello : 51*23 pollici-B

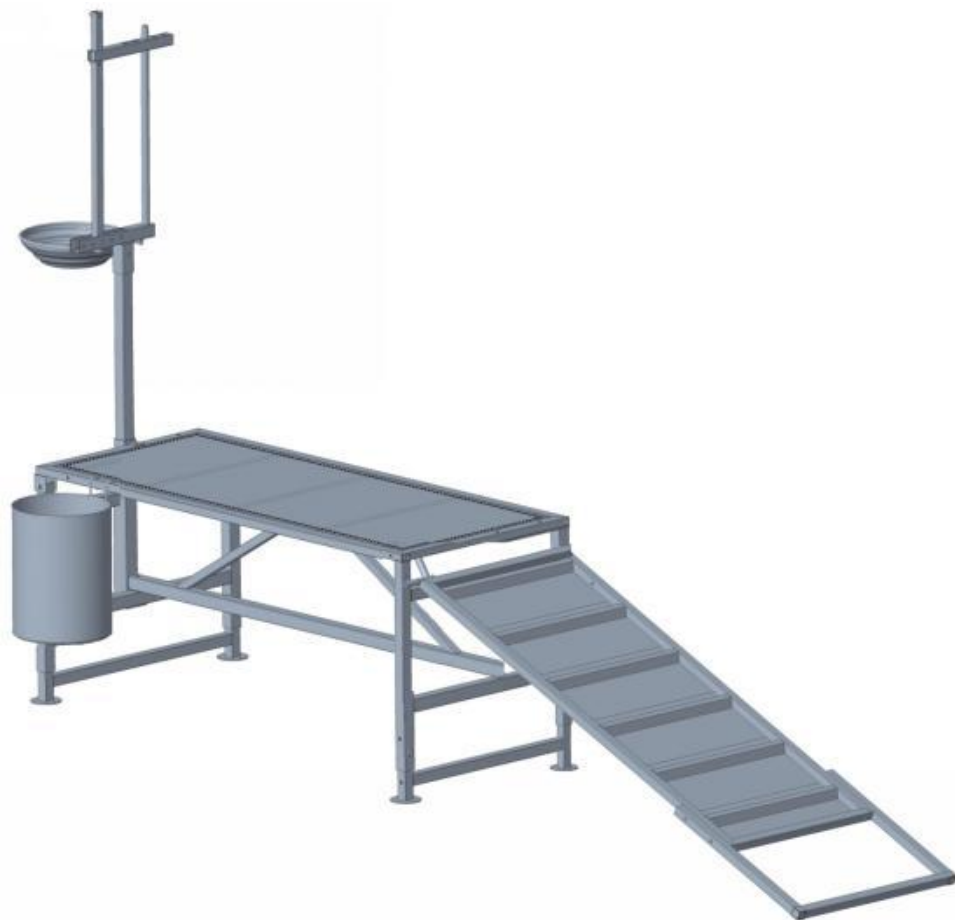

Queste sono le istruzioni originali, si prega di leggere attentamente tutte le istruzioni del manuale prima dell'uso. VEVOR si riserva il diritto di interpretare a proprio piacimento il presente manuale d'uso. L'aspetto del prodotto potrebbe differire leggermente da quello del prodotto ricevuto. Ci scusiamo se non vi informeremo tempestivamente di eventuali

aggiornamenti tecnologici o software del nostro prodotto.

SAFETY INSTRUCTIONS

AVVERTIMENTO:

Leggere attentamente queste informazioni prima di utilizzare il prodotto. La mancata osservanza di queste istruzioni può causare gravi lesioni.

Precauzioni per l'assemblea

85. Assemblare il prodotto seguendo esclusivamente queste istruzioni. Un assemblaggio improprio può comportare dei pericoli.
86. Durante l'assemblaggio, indossare occhiali di sicurezza omologati ANSI e guanti da lavoro resistenti.
87. Mantieni l'area di ritrovo pulita e ben illuminata.
88. Durante l'assemblea, tenere lontani gli astanti.
89. Non assemblare se si è stanchi o sotto l'effetto di alcol, droghe o farmaci.
90. Le funzionalità del prodotto si applicano solo ai prodotti assemblati correttamente e completamente.
91. Assemblare su una superficie piana, livellata, dura e liscia, in grado di sostenere in sicurezza il supporto per il bestiame.
92. Per ulteriori informazioni sui componenti elencati nelle pagine seguenti, fare riferimento allo schema di montaggio presente in questo manuale. Disimballare e separare tutti i componenti in un'area di lavoro pulita.
93. Il prodotto è conforme agli standard e alle normative vigenti. L'installazione di questo dispositivo deve essere conforme a tutte le normative applicabili e il suo utilizzo deve avvenire esclusivamente in aree ben ventilate. Si prega di leggere il manuale d'uso prima di installare e utilizzare l'apparecchiatura.
94. Questo apparecchio non è destinato all'uso da parte di persone (compresi i bambini) con ridotte capacità fisiche, sensoriali o mentali, o prive di esperienza e conoscenza, a meno che non siano state supervisionate o istruite sull'uso dell'apparecchio da una persona responsabile della loro sicurezza.

95. Questo apparecchio è destinato all'uso in ambito domestico e in applicazioni simili come:
- case coloniche;
96. Conservare il prodotto in modo appropriato. Prima dell'uso, verificare che il prodotto non presenti anomalie. In caso di anomalie, interromperne immediatamente l'utilizzo.











Adottare precauzioni



36. **NON SEDERSI O RIMANERE IN PIEDI SU QUESTO OGGETTO.**
37. Questo prodotto non è un giocattolo. Non permettere ai bambini di giocare con questo oggetto o di avvicinarsi ad esso.
38. Non superare quanto specificato capacità di carico.
39. Utilizzare esclusivamente per lo scopo previsto.
40. Ispezionare prima di ogni utilizzo; non utilizzare se le parti sono allentate o danneggiate.

CONSERVARE QUESTO MANUALE

PARTS LIST

NO.	Parte	Nome	Quantità
1		Scaffale mobile	1
2		Rack fisso	1
3		Palo lungo	1
4		Asta fissa	1
5		da tavolo	1
6		Gamba regolabile A	2
7		Gamba regolabile B	1
7-1		Gamba regolabile B	1

8		cerchio	1
9		Bacino	1
NO.	Parte	Nome	Quantità
10		Borsa degli attrezzi	1
11		Asta di collegamento	1
12		Rampa	1
13		Palo a forma di U	1
UN		Perno a sgancio rapido	5
B		Pomello in plastica	7
C		Vite M8*45mm	8
D		Noce M8	16
E		Perno a sgancio rapido	2

F		Vite M8*60mm	4
G		Vite M8*80mm	2

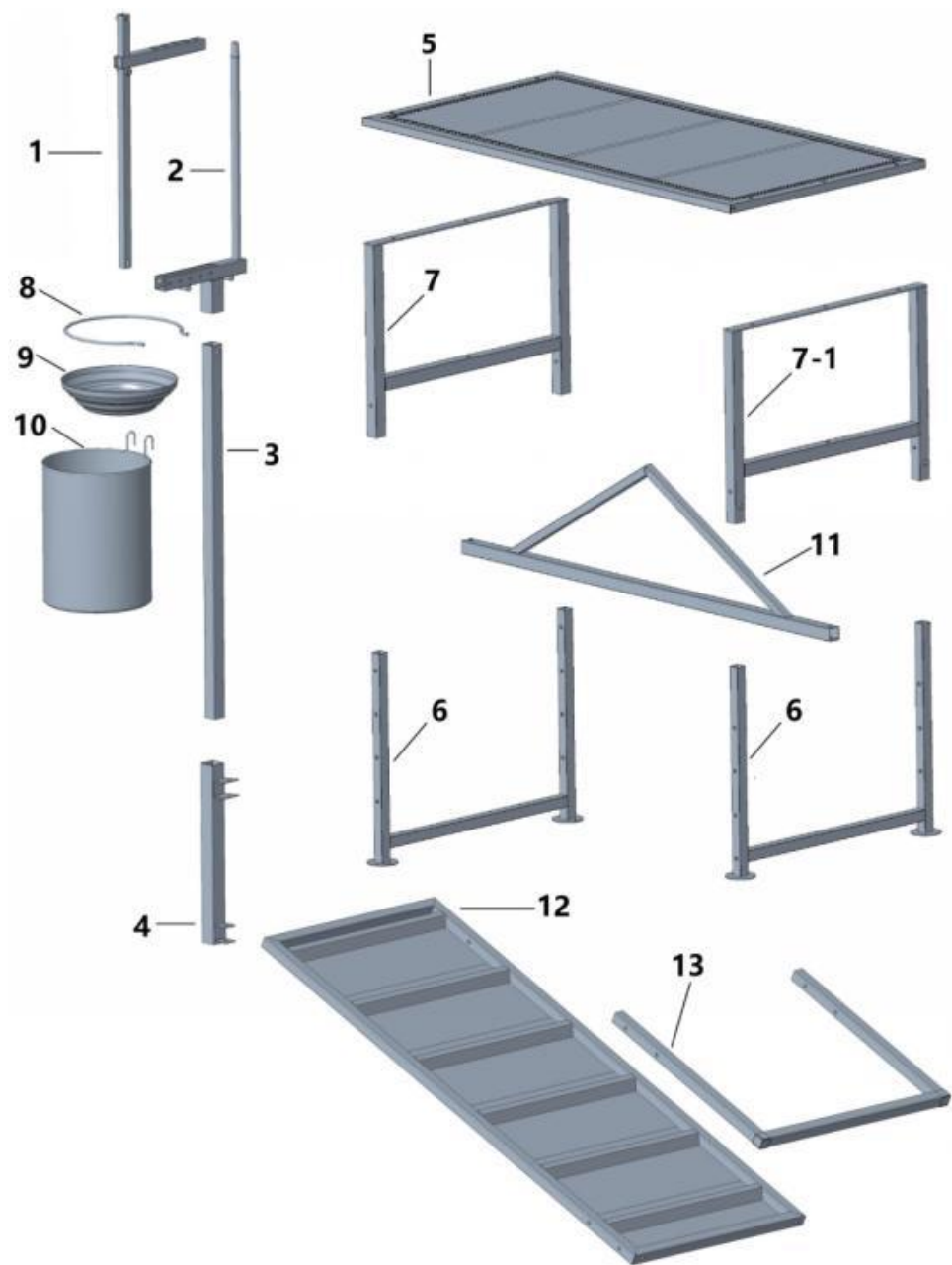

ASSEMBLY STEP

FASE 1

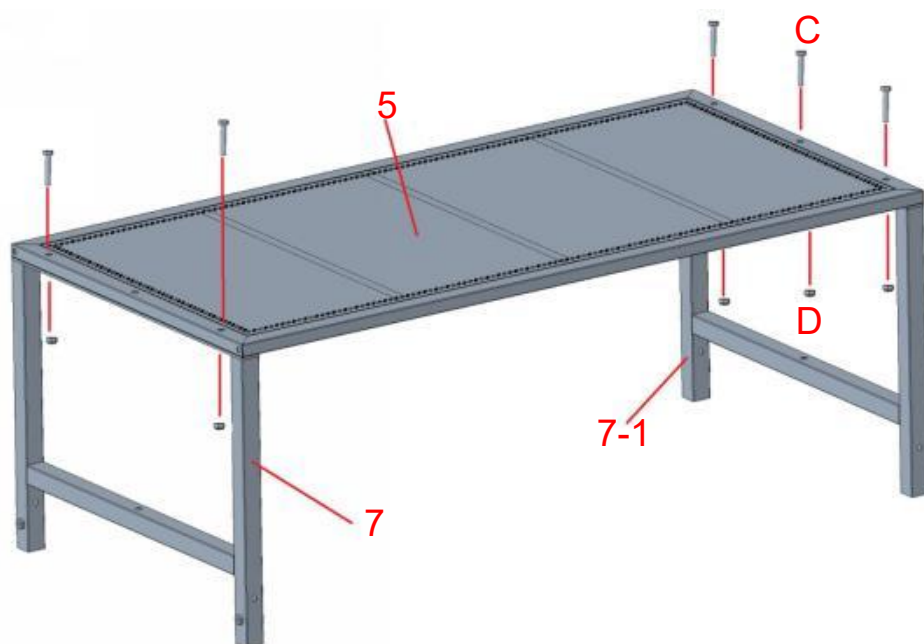

Fissare la gamba regolabile B (7) al piano del tavolo (5) con le viti (C) .

FASE 2



4 x1



11 X1



M8*35mm

C x2



D x4 M8*70mm



F x2

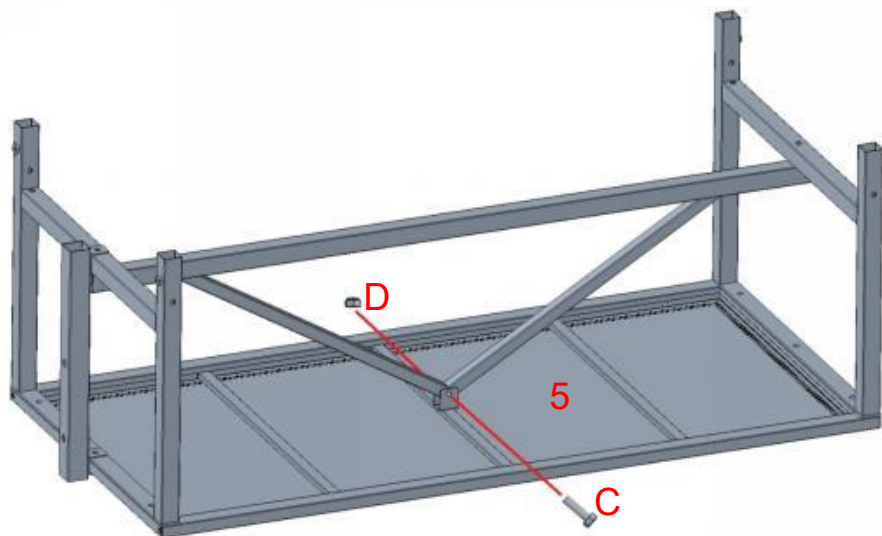
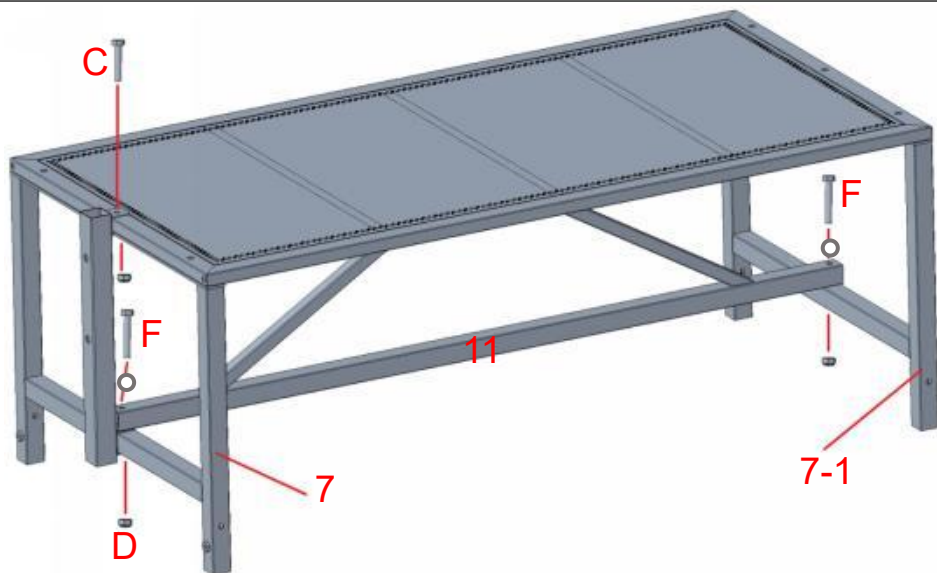

Fissare l' asta fissa (4) e la biella (11) al piano del tavolo (5) con le viti (C e H).

FASE 3

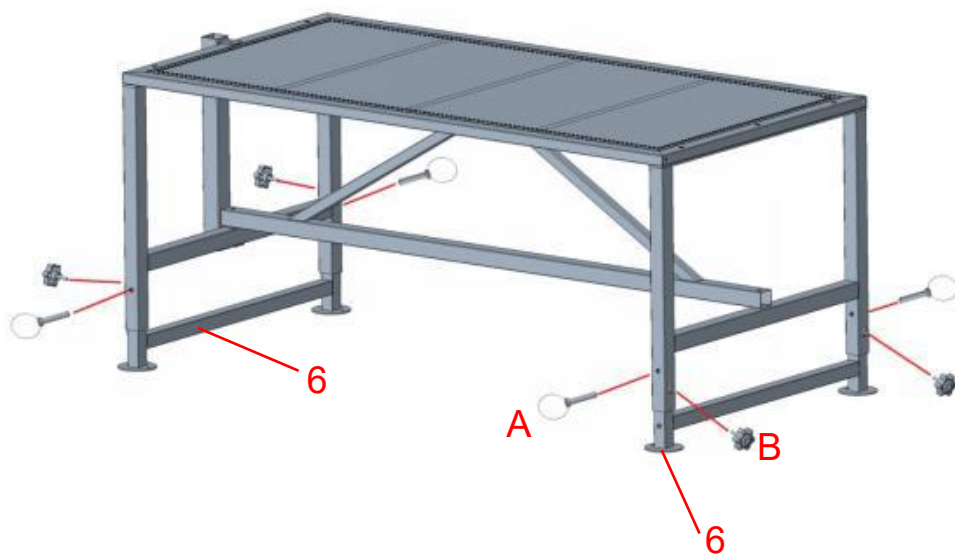
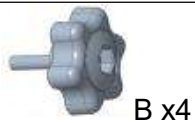

Inserire la gamba regolabile A (6) nella gamba di supporto e fissarla con il perno (A) e la manopola di plastica (B) .

FASE 4

3 x1



B x2

Note the
direction.



3

B

4

Inserire l' asta lunga (3) nel tubo fisso (4) e fissarla con la manopola di plastica (B) .

Nota: 1. Inserire l' asta lunga nella direzione indicata nel diagramma.
2. L'altezza dell'intero supporto per la testa di capra può essere regolata allentando o stringendo la manopola di plastica per spostare il lungo palo verso l'alto e verso il basso.

FASE 5-1

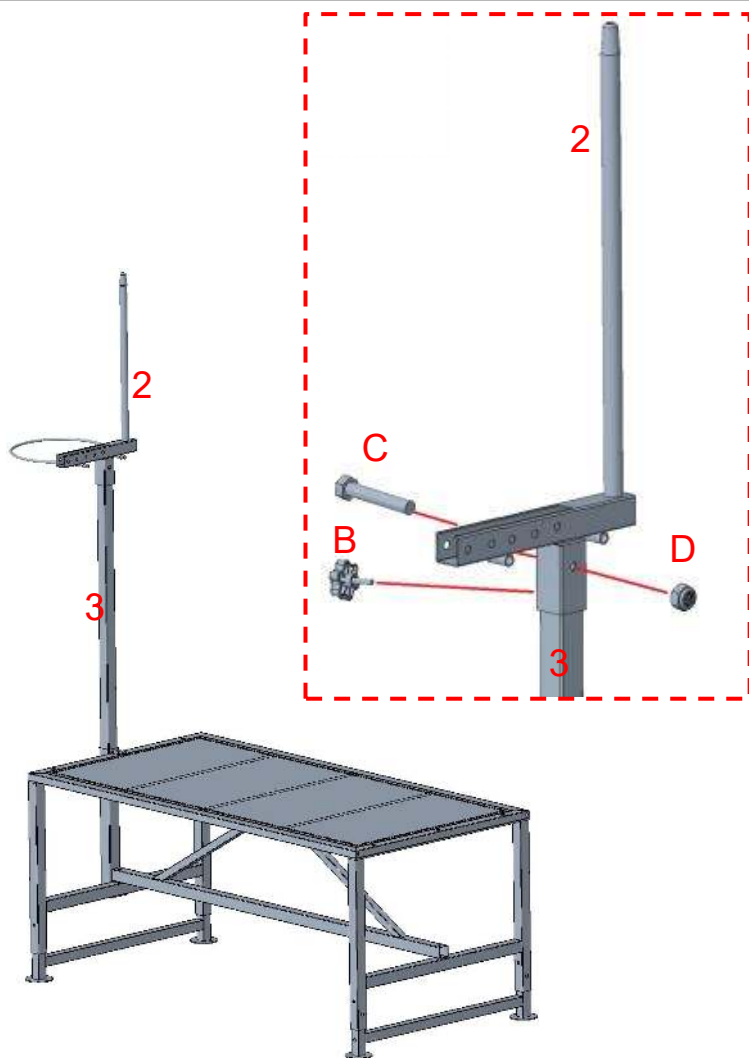

Fissare la staffa di montaggio della testa di capra (2) al palo lungo (3) con la vite (C) e il pomello di plastica (B) .

FASE 5-2



1 x1



A x1

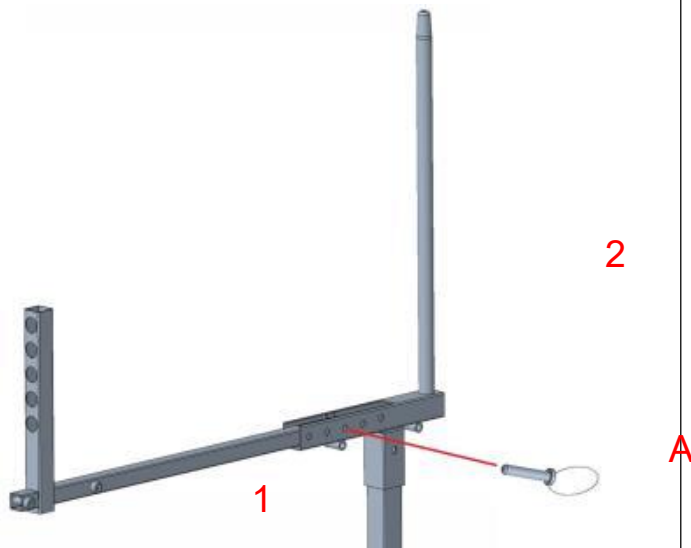

movable rack

Inserire il (1) nella staffa di montaggio della testa di capra (2) e fissarlo con un perno (A) .

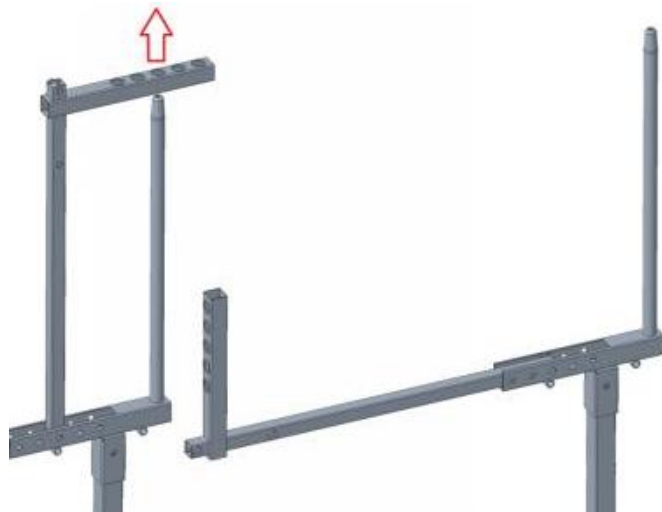

Sollevare la traversa mobile del supporto , allinearla con il tubo tondo del supporto fisso , quindi abbassarla in posizione.

FASE 6

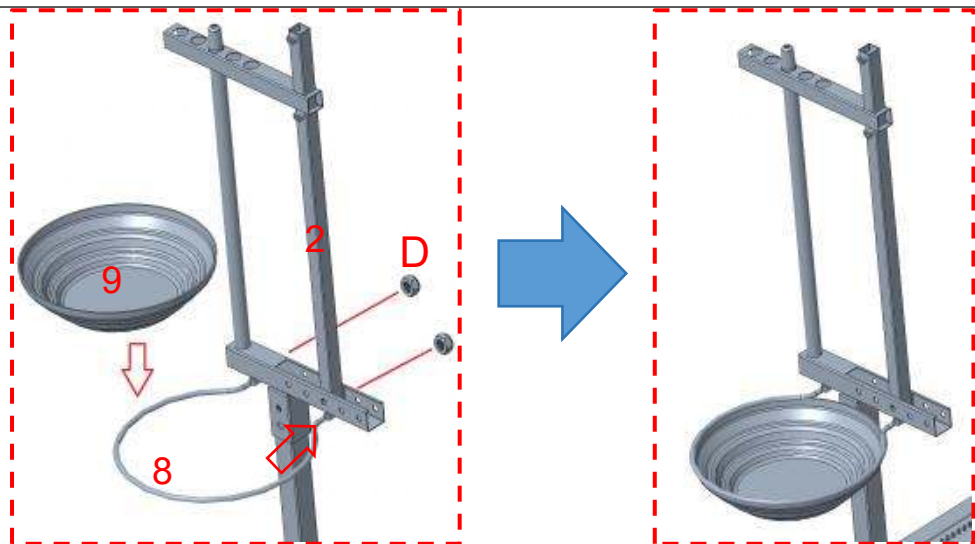
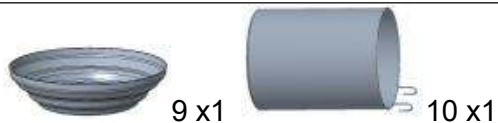

1. Inserire l'anello circolare (8) attraverso la staffa di montaggio della testa di capra (2) e serrarlo con le viti (D) .
2. Posizionare la bacinella (9) sul cerchio circolare per contenere acqua o foraggio.

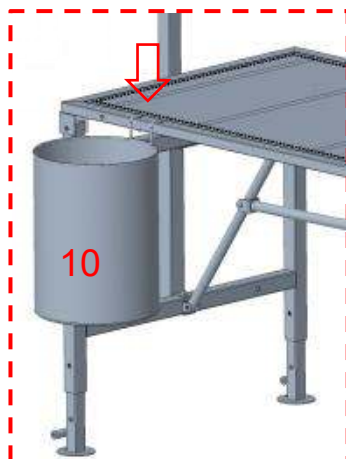

3. Appendere la borsa degli attrezzi (10) sulla piattaforma. La piattaforma è

dotata di 4 posizioni per una regolazione flessibile in base alle abitudini di utilizzo.

FASE 7

M8*70mm

F x4

D x4



14 x1



15 x1

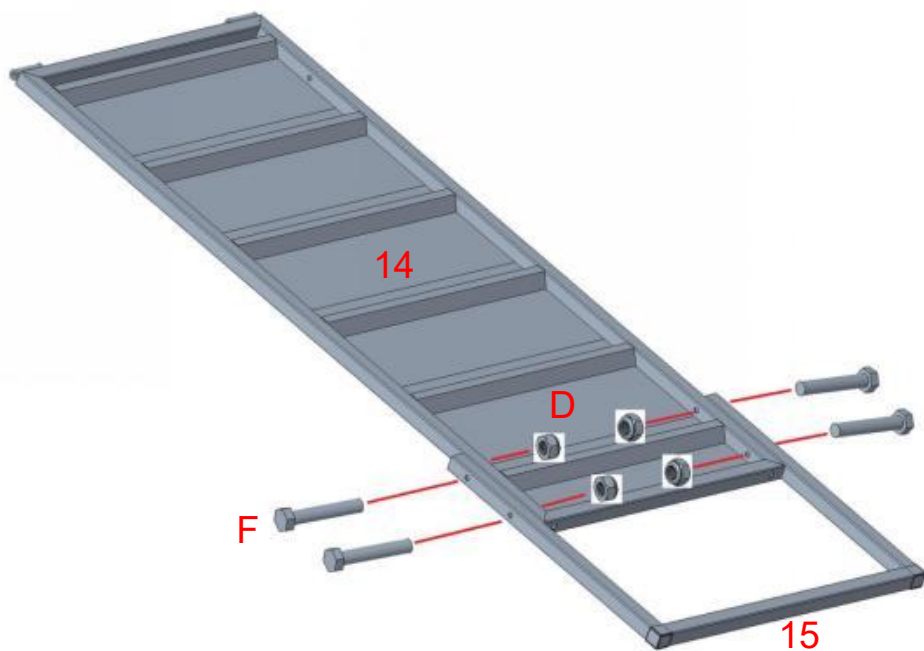

Fissare il palo a forma di U (15) alla rampa (14) con le viti (F) .

FASE 8

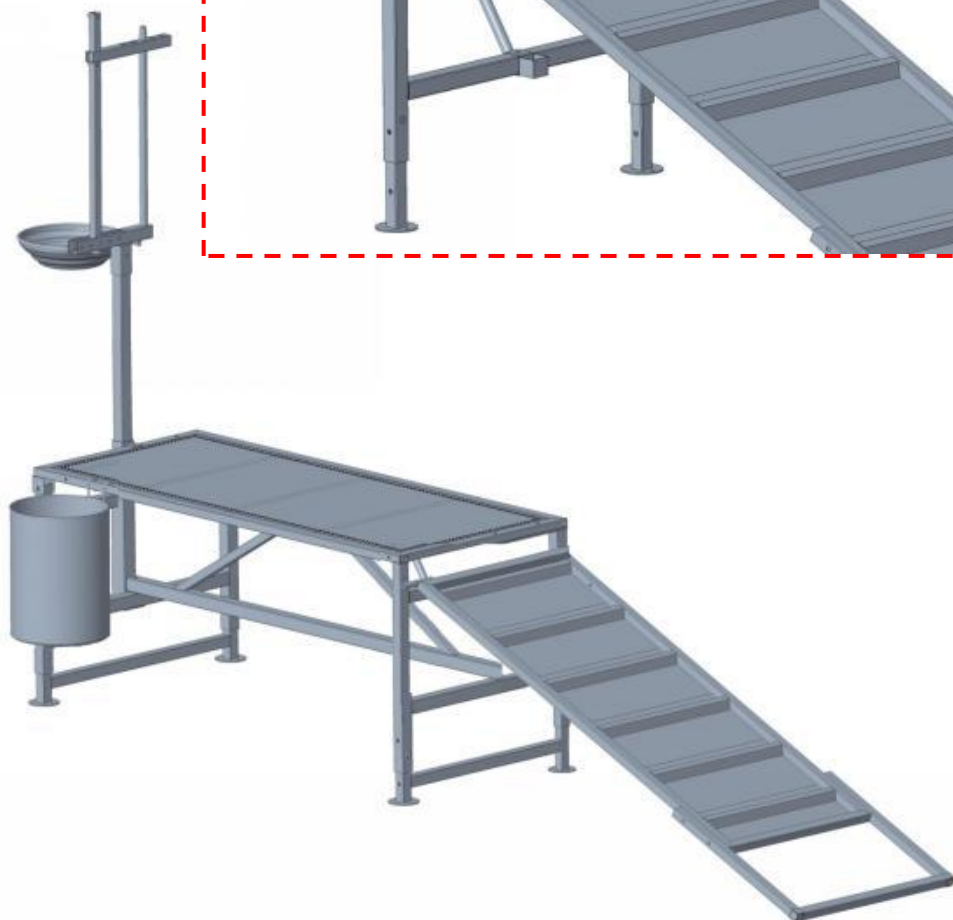
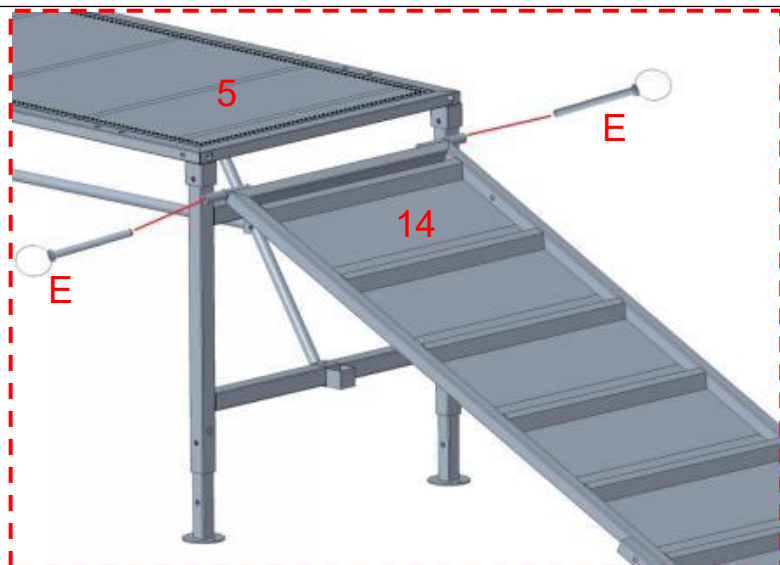

Assicurare il rampa (14) al piano del tavolo (5) con perni (E) .

Istruzioni per la regolazione della larghezza dell'archetto:



22. The fixed rack and movable rack are both equipped with 5 adjustment positions. The smaller the number, the narrower the spacing.
23. The upper and lower positions must be aligned to maintain a vertical state.
24. If you are unsure which position to choose, start with the middle position. If the goat's neck cannot be securely fixed, use a position with a smaller spacing.

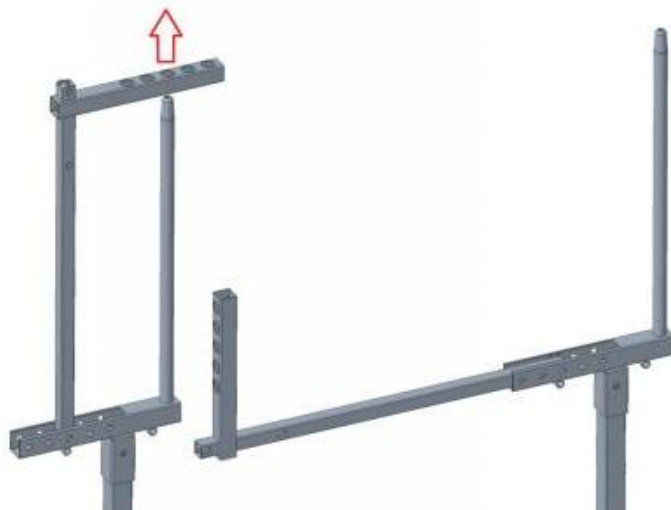

Sollevare la traversa mobile del supporto , allinearla con il tubo tondo del supporto fisso , quindi abbassarla in posizione.

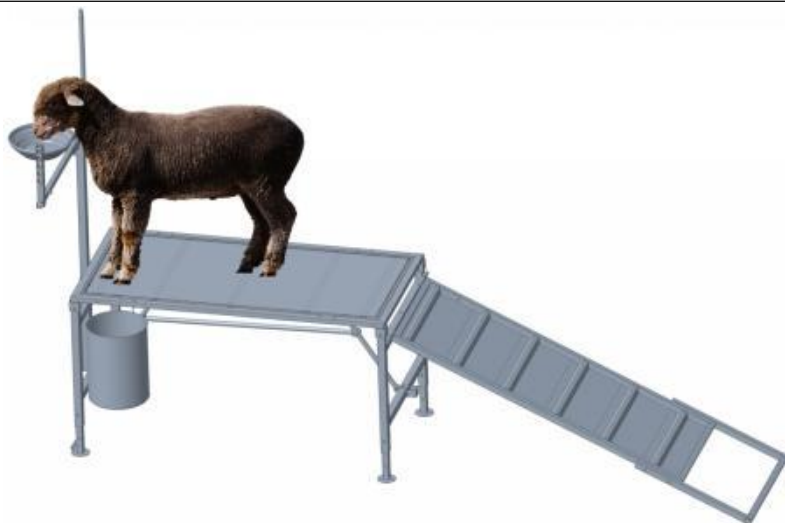

Apri la staffa e guida la capra verso la rastrelliera fissa .

Nota: Regolare l'altezza del supporto fisso in modo che la parte inferiore del collo della capra sia all'altezza della traversa inferiore del supporto. Questa posizione consente alla capra di abbassare la testa per bere o mangiare, senza toccare la traversa superiore e rischiare di dislocarsi quando la alza.



Sollevare la traversa mobile del supporto , allinearla con il tubo tondo del supporto fisso , quindi abbassarla in posizione.

PRODUCT PARAMETER

Modello	51*23 pollici-B
Peso di carico sicuro	600 libbre/272 kg
Colore	Nero
Dimensioni desktop	51*23 pollici (1295*584 mm)

Manufacturer: Shanghai Sishun Technology Co., Ltd
Address: 4th Floor, Building 2, No. 599 Wan Zhen Road, Zhenxin Xincun Subdistrict, Jiading District, Shanghai, 201800 China
E-mail: support@vevor.com

Imported to AUS: SIHAO PTY LTD. 1 ROKEVA STREET EASTWOOD NSW 2122 Australia

Imported to USA: Sarven Technology Ltd. Suite 250, 9166 Anaheim Place, Rancho Cucamonga, CA 91730

VEVOR SUPER TOOLS LIMITED

EC REP

Address: Office 403, Nesta Business Centre, 4-5 Burton Hall Rd, Sandyford, Dublin 18, D18 A094, Ireland

Email: service-eu@vevor.com Tel: +353874373999

VEVOR TOOL HUB LIMITED

UK REP

Address: 2 Goldstone Close, Brighton and Hove, BN3 7PD, United Kingdom

Email: service-uk@vevor.com Tel: +447795204660

