

Service Instructions

for use by heating contractors

VIESSMANN®

Vitodens 200-W, B2HA

Models 112, 150, 399, 530

Wall-mounted, gas-fired condensing boiler

Natural gas and LPG version

For operation with Natural Gas and Liquid Propane Gas

Heating input 113 to 530 MBH

33 to 150 kW



VITODENS® 200-W



Product may not be exactly as shown

IMPORTANT

Read and save these instructions for future reference.

Safety, Installation and Warranty Requirements

Please ensure that these instructions are read and understood before commencing installation. Failure to comply with the instructions listed below and details printed in this manual can cause product/property damage, severe personal injury, and/or loss of life. Ensure all requirements below are understood and fulfilled (including detailed information found in manual subsections).

■ **Product documentation**

Read all applicable documentation before commencing installation. Store documentation near boiler in a readily accessible location for reference in the future by service personnel.

► *For a listing of applicable literature, please see section entitled "Important Regulatory and Safety Requirements".*



■ **Warranty**

Information contained in this and related product documentation must be read and followed. Failure to do so renders the warranty null and void.



■ **Licensed professional heating contractor**

The installation, adjustment, service and maintenance of this equipment must be performed by a licensed professional heating contractor.

► *Please see section entitled "Important Regulatory and Installation Requirements".*



■ **Contaminated air**

Air contaminated by chemicals can cause by-products in the combustion process, which are poisonous to inhabitants and destructive to O equipment.

► *For a listing of chemicals which cannot be stored in or near the boiler room, please see subsection entitled "Mechanical room" in the "Installation Instructions".*



■ **Advice to owner**

Once the installation work is complete, the heating contractor must familiarize the system operator/ultimate owner with all equipment, as well as safety precautions/requirements, shutdown procedure, and the need for professional service annually before the heating season begins.

■ **Carbon monoxide**

Improper installation, adjustment, service and/or maintenance can cause flue products to flow into living space. Flue products contain poisonous carbon monoxide gas.

► *For information pertaining to the proper installation, adjustment, service and maintenance of this equipment to avoid formation of carbon monoxide, please see subsection entitled "Mechanical room" and "Venting requirements" in the "Installation Instructions".*



■ **Fresh air**

This equipment requires fresh air for safe operation and must be installed ensuring provisions for adequate combustion and ventilation air exist.

► *For information pertaining to the fresh air requirements of this product, please see subsection entitled "Mechanical room" in the "Installation Instructions".*

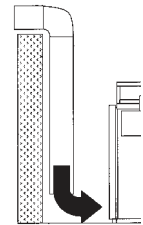

■ **Equipment venting**

Never operate boiler without an installed venting system. An improper venting system can cause carbon monoxide poisoning.

► *For information pertaining to venting and chimney requirements, please see section entitled "Venting Connection". All products of combustion must be safely vented to the outdoors.*



! WARNING

Installers must follow local regulations with respect to installation of carbon monoxide detectors. Follow the Viessmann maintenance schedule of the boiler contained in this manual.

! WARNING

This boiler requires fresh air for safe operation and must be installed with provisions for adequate combustion and ventilation air (in accordance with local codes and regulations of authorities having jurisdiction).

Do not operate this boiler in areas with contaminated combustion air. High levels of contaminants such as dust, lint or chemicals can be found at construction sites, home renovations, in garages, workshops, in dry cleaning/laundry facilities, near swimming pools and in manufacturing facilities.

Contaminated combustion air will damage the boiler and may lead to substantial property damage, severe personal injury and/or loss of life. Ensure boiler/burner is inspected and serviced by a qualified heating contractor at least once a year in accordance with the Service Instructions of the boiler.

Operating and Service Documentation

It is recommended that all product documentation such as parts lists, operating and service instructions be handed over to the system user for storage. Documentation is to be stored near boiler in a readily accessible location for reference by service personnel.

Safety, Installation and Warranty Requirements *(continued)*

Fiberglass wool and ceramic fiber materials



WARNING

Inhaling of fiberglass wool and/or ceramic fiber materials is a possible cancer hazard. These materials can also cause respiratory, skin and eye irritation.

The state of California has listed the airborne fibers of these materials as a possible cancer hazard through inhalation. When handling these materials, special care must be applied.

Suppliers of ceramic fiber products recommend the following first aid measures:

- *Respiratory tract (nose and throat) irritation:*
If respiratory tract irritation develops, move the person to a dust free location.
- *Eye irritation:* If eyes become irritated, flush immediately with large amounts of lukewarm water for at least 15 minutes. Eyelids should be held away from the eyeball to ensure thorough rinsing. Do not rub eyes.
- *Skin irritation:* If skin becomes irritated, remove soiled clothing. Do not rub or scratch exposed skin. Wash area of contact thoroughly with soap and water. Using a skin cream or lotion after washing may be helpful.
- *Gastrointestinal irritation:* If gastrointestinal tract irritation develops, move the person to a dust free environment.

Suppliers of fiberglass wool products recommend the following precautions be taken when handling these materials:

- Avoid breathing fiberglass dust and contact with skin and eyes.
- Use NIOSH approved dust/mist respirator.
- Wear long-sleeved, loose fitting clothing, gloves and eye protection.
- Wash work clothes separately from other clothing. Rinse washer thoroughly.
- Operations such as sawing, blowing, tear-out and spraying may generate airborne fiber concentration requiring additional protection.

First aid measures

- If eye contact occurs, flush eyes with water to remove dust. If symptoms persist, seek medical attention.
- If skin contact occurs, wash affected areas gently with soap and warm water after handling.



WARNING

Appliance materials of construction, products of combustion and the fuel contain alumina, silica, heavy metals, carbon monoxide, nitrogen oxides, aldehydes and/or other toxic or harmful substances which can cause serious injury or loss of life and which are known to the State of California to cause cancer, birth defects and other reproductive harm. Always use proper safety clothing, respirators and equipment when servicing or working nearby the appliance.

Safety

Safety, Installation and Warranty Instructions.....2

General Information

About these Service Instructions.....6
Necessary Tools.....6
Important Regulatory and Installation Requirements.....7
 CSD-1 Field Testing of High Limit Switches.....8
Applicability.....9
Product Information.....9
Mechanical Room.....10

Start-up

Accessing the User Interface Programming Unit.....11
Check Power Supply Connection.....11
Start-up Wizard.....12
Removing Front Enclosure Panel.....15
Fill Condensate Trap with Water.....15
Fill Heating System with Water.....16
Bleed (Vent) Air from Boiler Heat Exchanger.....17
Designating Heating Circuits.....18
Select Gas Type.....18
Convert Fuel Type to Liquid Propane Gas.....19
Setting High Altitude.....19
Measure Static Pressure and Running Pressure.....20
Pressure Switches.....21
Sequence of Operation and Potential Faults
During Each Start-up Cycle.....22
Set Maximum Input.....23
Check all Primary and Secondary Circuit
Connections for Leaks.....23
Perform Combustion Analysis.....23
Check Coaxial Venting System for Leaks.....24

Service

Remove Burner Assembly.....24
Reinstall Burner Assembly.....24
Checking the Flue Gas Flapper.....25
Check Burner Refractory.....25
Check and Adjust Ignition and Ionization Electrodes.....26
Clean Combustion Chamber/Heat Exchanger Surface.....26
Check Condensate Drain.....27
Check Neutralization Unit (if applicable).....28
Check Diaphragm Expansion Tank and System Pressure...28
Check Functioning of Safety Valves.....29
Check Electrical Connections.....29
Check Pipes and Fittings for Leaks.....29
Clock Natural Gas Meter.....30
Check CO₂ Setting.....31

Outdoor Reset Programming Unit

Start-up and Shutdown.....32
 Menu.....32
 Zone Circuit Display.....33
 Functional Description.....34
 Combustion Management Systems.....34
 Installation Examples.....35
 Heating Curve Adjustments.....40
 Connecting the Boiler Control to a LON System.....42

Coding 1

General.....44
 Boiler.....46
 DHW.....46
 Solar.....47
 Heating Circuit 1, 2 and 3.....48

Coding 2

General.....52
 Boiler.....60
 DHW.....61
 Solar.....63
 Heating Circuit 1, 2 and 3.....67

Diagnosis and Service Scans

Calling up the Service Level.....73
 Diagnosis.....74
 Checking Outputs (Relay Test).....76

Troubleshooting

Fault Display.....77
 Fault Codes.....77
 Corrective Action.....85
 Continuous boiler pump operation.....85
 Checking the outside temperature sensor.....85
 Check fuse.....85
 Check fuses in the external accessories
 connection box.....85
 Checking the boiler temperature sensor and
 fixed high limit, DHW tank temperature sensor or
 flow temperature sensor for the low loss header.....86
 Check the flue gas temperature sensor.....86
 Replacing the flow rate sensor.....87
 Extension kit for heating circuit with mixing valve.....88
 Checking the rotational direction of the mixing valve
 motor.....88
 Changing the rotational direction of the
 mixing valve motor (if required).....88
 Checking the Vitotronic 200-H (accessories).....88

Function Description

External Extensions AM1 (accessory).....89
 Internal Extensions EA1.....90
 Control Functions.....92

Additional Information

Wiring Diagram.....95
 Burner Program Sequence of Operation.....97
 Parts List.....98
 Technical Data.....103
 Maintenance Record.....105
 Lighting and Operating Instructions.....106

About these Service Instructions



Take note of all symbols and notations intended to draw attention to potential hazards or important product information. These include "WARNING", "CAUTION", and "IMPORTANT". See below.



WARNING

Indicates an imminently hazardous situation which, if not avoided, could result in loss of life, serious injury or substantial product/property damage.

► Warnings draw your attention to the presence of potential hazards or important product information.



CAUTION

Indicates an imminently hazardous situation which, if not avoided, may result in minor injury or product/property damage.

► Cautions draw your attention to the presence of potential hazards or important product information.

IMPORTANT

► Helpful hints for installation, operation or maintenance which pertain to the product.



► This symbol indicates that additional, pertinent information is to be found.



► This symbol indicates that other instructions must be referenced.

Necessary Tools

Testing/analysis equipment (Use only calibrated equipment)

- Multimeter to measure 0 - 120V, 0 - 12A AC and 0-100 mA DC
- Flue gas analyzer to measure % CO₂ or O₂ (i.e. Bacharach fluid samplers or suitable electronic analyzer)
- Manometer to measure gas pressure 0 to 11 "w.c. (accurately) and up to 28 "w.c. gas pressure (or a non-electric Magnehelic® manometer may also be utilized)
- Stack thermometer 0 to 500°F (0 to 260°C)
- Bacharach calculator or suitable tables to calculate efficiency
- Carbon monoxide measuring equipment 0 to 400 ppm

Cleaning supplies

- Plastic hand brush
- Rags

Special items

- Approved leak detection fluid for natural gas and liquid propane gas
- Pipe joint sealant

Important Regulatory and Installation Requirements

Codes

The installation of this unit shall be in accordance with local codes or, in the absence of local codes, use CAN/CSA-B149.1 or .2 Installation Codes for Gas Burning Appliances for Canada. For U.S. installations use the National Fuel Gas Code ANSI Z223.1. Always use latest editions of codes.

In Canada all electrical wiring is to be done in accordance with the latest edition of CSA C22.1 Part 1 and/or local codes. In the U.S. use the National Electrical Code ANSI/NFPA 70. The heating contractor must also comply with both the Standard for Controls and Safety Devices for Automatically Fired Boilers, ANSI/ASME CSD-1, and the Installation Code for Hydronic Heating Systems, CSA B214-01, where required by the authority having jurisdiction.

Instructing the system user

The installer of the system is responsible to ensure the system operator/ultimate owner is made familiar with the system functioning, its activation, and its shut-down.

Initial start-up

Initial start-up must be performed by a qualified heating contractor. Proper completion of the Maintenance Record by the heating contractor is also required.

Working on the equipment

The installation, adjustment, service, and maintenance of this boiler must be done by a licensed professional heating contractor who is qualified and experienced in the installation, service, and maintenance of hot water boilers. There are no user serviceable parts on the boiler, burners or control.

Ensure main power supply to equipment, the heating system, and all external controls has been deactivated. Close main gas supply valve. Take precautions in all instances to avoid accidental activation of power during service work.

The completeness and functionality of field supplied electrical controls and components must be verified by the heating contractor. These include low water cut-offs, flow switches (if used), staging controls, pumps, motorized valves, air vents, thermostats, etc.

Carbon Monoxide Detectors

The installer must verify that at least one carbon monoxide alarm has been installed within a residential living space or home following the alarm manufacturer's instructions and applicable codes before putting the appliance into operation.

The following topics must be covered:

Proper system operation sequence.

Explain the equipment.

Demonstrate an emergency shut-down, what to do and what not.

Explain that there is no substitute for proper maintenance to help ensure safe operation.

The Maintenance Record is located in the Service Instructions

Please carefully read this manual prior to attempting start-up, maintenance or service. Any warranty is null and void if these instructions are not followed.

For information regarding other Viessmann System Technology componentry, please reference documentation of the respective product.

We offer frequent installation and service seminars to familiarize our partners with our products. Please inquire.

Technical literature

Literature for the Vitodens boiler:

- Technical Data Manual

- Installation Instructions

- Service Instructions

- Operating Instructions and User's Information Manual

- Instructions of other Viessmann products utilized and installed

- Installation codes mentioned in this manual

Leave all literature at the installation site and advise the system operator/ultimate owner where the literature can be found. Contact Viessmann for additional copies.

This product comes with several safety instruction labels attached.

Do not remove!

Contact Viessmann immediately if replacement labels are required.

Important Regulatory and Installation Requirements *(continued)*

CSD-1 Field Testing of High Limit Switches for Vitodens boilers – where required by law.

As per ASME Boiler and Pressure Vessel Code, section IV, subsection HG-613 TEMPERATURE CONTROL requirements, Vitodens 200-W hot water boilers are protected from over-temperature by two temperature-operated controls. These temperature control devices conform to Standards for Limit Controls, and are accepted by CSA, a nationally recognized testing agency. Each boiler is equipped with a manual reset high temperature limit control and a temperature control that will cut off fuel supply when the system water temperature reaches a preset operating temperature. VIESSMANN IS NOT RESPONSIBLE FOR ANY DAMAGES THAT THE FOLLOWING TEST PROCEDURE MAY RESULT IN BY OVERHEATING THE SYSTEM.

The Vitodens 200 boilers are equipped with flow switches or sensors that when activated enable the burner to operate. The fixed high limit, when tripped, produces a fault that will require manual reset of the boiler control.

Fixed High Limit fault simulation #1:

- Ensure that the boiler and boiler pump are in normal operating condition (pump output [20] is the boiler pump).
- Remove the cover from the back of the boiler control allowing access to the boiler control plugs.
- Under the extended menu (in the Operating manual), select 'Test mode' then 'flue gas test ON' and press 'OK'.
- The boiler/burner will start a firing cycle and will gradually go into high fire mode.
- Once the burner ignites, disconnect the boiler pump plug [20] from the boiler control board (gently with pliers).
Note: For boiler models equipped with flow switches (only boiler sizes 19 to 100), it may be required that flow switches be jumpered during testing.
- Observe the boiler temperature on the control display.
- The temperature will gradually rise as more heat is put into the boiler heat exchanger. The burner will then shut off.
- The boiler temperature should continue to rise and once it reaches 210°F (99°C) the manual reset high limit safety switch will trip electronically generating an F2 fault.
- Should the limit temperature not be reached during the test, repeat the test with the following additional step;
- Two minutes after the burner shuts off, energize the boiler pump for a maximum of 1 second (by plugging in boiler pump plug [20]).

Fixed High Limit fault simulation #2:

- Close the boiler valve and jumper across the flow switch.
- Run the boiler at high fire and it will shut down by the coding card (in B2TB models, set coding address 06 to maximum) but should continue to steady increase the boiler temperature until the fixed high limit is tripped.
- Once the fixed high limit is tripped, slowly open the boiler valve to safely cool the boiler down.

Flow Switch /Sensor Test:

The Vitodens 200 B2HA models 399, 530, 112 and 150 boilers are equipped with two flow sensing devices. Upon detection of an inadequate flow rate, the switches will shut down the burner and will prevent restarting until an adequate flow rate is restored. To test the sensors, throttle down the flow of water to or from the boiler. The boiler will shut down once the flow has dropped below it's safe operating set point.

Applicability

CAUTION

The boiler serial number must be provided when ordering replacement parts. Some replacement parts are not reverse compatible with previous versions of the Vitodens 200-W B2HA boiler.

IMPORTANT

When ordering replacement parts, provide either the 16-digit boiler serial number (on the bar code label) or the 12-digit ASME/NB serial number, located as shown underneath boiler front enclosure panel. Refer to page 15 for instructions on how to remove front enclosure panel.

Model No. B2HA 112, 399

Serial No. 7510835□□□□□□□□□□
7550393□□□□□□□□□□

Model No. B2HA 150, 530

Serial No. 7510836□□□□□□□□□□
7550394□□□□□□□□□□

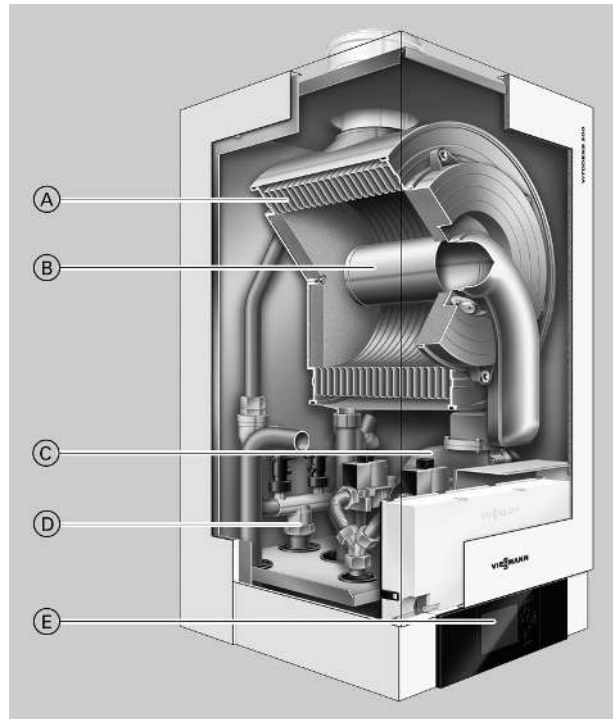

Product may not be exactly as shown

- Ⓐ Innox-Radial heat exchanger made from stainless steel – for high operational reliability and a long service life. Large heating output in the smallest of spaces
- Ⓑ Modulating MatriX cylinder burner for extremely clean combustion and quiet operation
- Ⓒ Variable speed combustion fan for quiet and economical operation
- Ⓓ Gas and water connections
- Ⓔ Digital boiler control unit

Product Information

Natural gas-fired wall-mounted condensing heating boiler for weather-responsive operation in closed loop, forced circulation hot water heating systems for space heating and domestic hot water (DHW) production.

Models B2HA series boilers are for operation with natural gas. For a fuel conversion to liquid propane gas (see page 19).

Boiler model must be selected based on an accurate heat loss calculation of the building. Ensure boiler model is compatible with connected radiation.

Vitodens 200-W, B2HA series boilers are factory-tested and calibrated. Further gas valve adjustments are not typically required during field start-up.

Multi boiler system

In connection with the installation of a multi boiler system observe the installation instructions of the multi boiler system accessories.



Follow the Vitodens Venting System Installation Instructions to vent this boiler.

Mechanical Room

During the early stages of designing a new home, we recommend that proper consideration be given to constructing a separate mechanical room dedicated to the gas- or oil-fired heating equipment and domestic hot water storage tank(s).

The boiler must be located in a heated indoor area, near a floor drain, and as close as possible to a wall. Whenever possible, install the boiler near an outside wall so that it is easy to duct the venting system to the boiler.

Locate the boiler on a wall capable of supporting the weight of the boiler filled with water (see section entitled "Technical Data" on page 98 for information required for total boiler weight calculation). Ensure that the boiler location does not interfere with the proper circulation of combustion and ventilation air of other fuel burning equipment within the mechanical room (if applicable).

The maximum room temperature of the mechanical room where the boiler is located must not exceed 104°F (40°C).

Installation area conditions

WARNING

Incorrect ambient conditions can lead to damage to the heating system and put safe operation at risk.

- Ensure ambient temperatures are higher than 32°F (0°C) and lower than 104°F (40°C).
- Prevent the air from becoming contaminated by halogenated hydrocarbons (e.g. as contained in paint solvents or cleaning fluids) and excessive dust (e.g. through grinding or polishing work). Combustion air for the heating process, and ventilation of the boiler room must be free of corrosive contaminants. To that end, any boiler must be installed in an area that has no chemical exposure. The list to the right indicates the main, currently known sources.
- Avoid continuously high levels of humidity (e.g. through frequent drying of laundry).
- Never close existing ventilation openings.

WARNING

If you notice fire coming from the appliance, call the fire department immediately! Do not attempt to extinguish the fire unless qualified to do so.

IMPORTANT

The service life of the boiler's exposed metallic surfaces, such as the casing and fan housing, is directly influenced by proximity to damp and salty marine environments. In such areas, higher concentration levels of chlorides from sea spray, coupled with relative humidity, can lead to degradation of the exposed metallic surfaces mentioned above. Therefore, it is imperative that boilers installed in such environments not be installed using direct vent systems which draw outdoor air for combustion. Such boilers must be installed using room air dependent vent systems; i.e. using room air for combustion. The indoor air will have a much lower relative humidity and, hence, potential corrosion will be minimized.

Sources of combustion and ventilation air contaminants

Areas likely to contain contaminants:

- New building construction
- Swimming pools
- Remodelling areas, hobby rooms
- Garages with workshops
- Furniture refinishing areas
- Dry cleaning/laundry areas and establishments
- Auto body shops
- Refrigeration repair shops
- Metal fabrication plants
- Plastic manufacturing plants
- Photo processing plants
- Beauty salons

Products containing contaminants:

- Chlorine-type bleaches, detergents and cleaning solvents found in household laundry rooms
- Paint and varnish removers
- Hydrochloric acid, muriatic acid
- Chlorine-based swimming pool chemicals
- Spray cans containing chlorofluorocarbons
- Chlorinated waxes and cleaners
- Cements and glues
- Refrigerant leaks
- Calcium chloride used for thawing
- Sodium chloride used for water softening salt
- Permanent wave solutions
- Adhesives used to fasten building products and other similar items
- Antistatic fabric softeners used in clothes dryers

Boiler operation in marine environments (damp, salty coastal areas)

WARNING

Fire causes a risk of burns and explosion!

- Shut down the boiler
- Close fuel shut-off valves
- Use a tested fire extinguisher, class ABC.

Accessing the User Interface Programming Unit

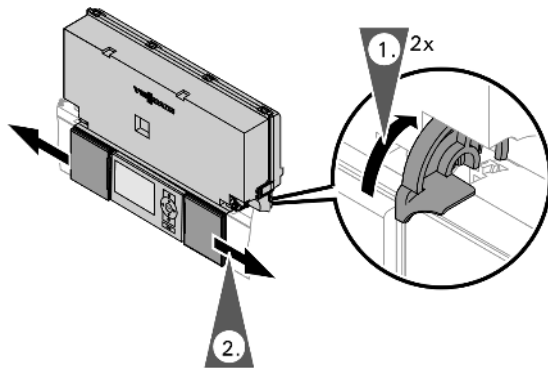

1. Turn up both locks to unlock the user interface programming unit covers.
2. Slide open the user interface programming unit covers.

Check Power Supply Connection

An external accessories connection box is attached to the Vitodens 200-W, B2HA boiler, which requires a 120VAC power supply from a wall receptacle (15A fuse protected).

Refer to the Installation Instructions shipped with the boiler.

Voltage range

The voltage at connector **40** of the boiler control must be 120V (see wiring diagram).

Neutral conductor

The electrical power supply must have a neutral conductor.

IMPORTANT

In Canada all electrical wiring is to be done in accordance with the latest edition of CSA C22.1 Part 1 and/or local codes. In the U.S. use the National Electrical Code ANSI/NFPA 70. The heating contractor must also comply with both the Standard for Controls and Safety Devices for Automatically Fired Boilers, ANSI, ASME CSD-1.

Note: The outer conductor "L" and the neutral conductor "N" must not be interchanged.

See wiring diagram on page 95 in section entitled "Additional Information".

Start-up Wizard



Select Language

At the commissioning stage, the display is in German.

1. "Sprache" (Language) Deutsch DE (German)
2. Select the required language with ▲/▼
3. Accept by pressing OK

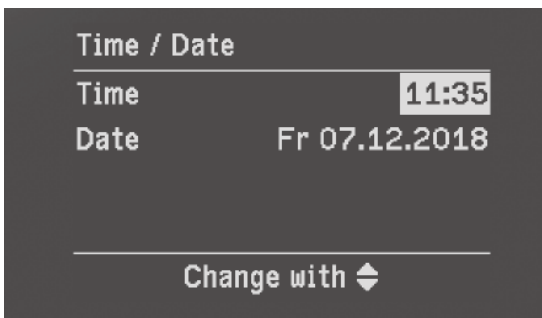

Set time and date

1. Using the ▲/▼ set the current time
2. Accept by pressing OK, this will move to date
3. Using the ▲/▼ set the current date
4. Press OK to complete

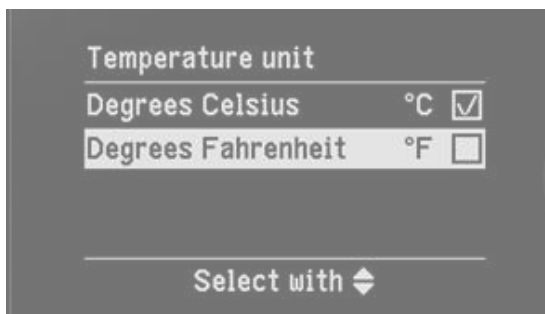

Select temperature unit

1. Select the temperature unit "°C" or "°F" using the ▲/▼
2. Accept by pressing OK

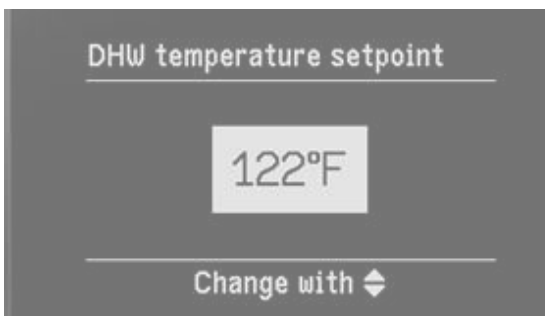

Set DHW temperature setpoint

1. Set DHW temperature setpoint with ▲/▼
2. Accept by pressing OK

Note: if the DHW sensor is installed.

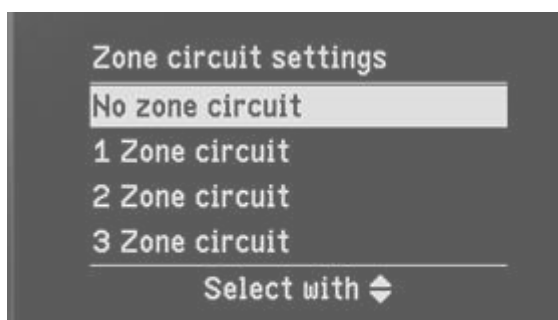

Select zone circuits

During the start-up wizard an additional display screen will come up asking for the number of connected zone circuits use ▲/▼ to adjust and press OK.

If no zone circuit is selected the control will finish the set up and display will show DHW/Heating circuit 1, outdoor temperature, indoor temperature setup and burner operating status.

Start-up Wizard *(continued)*

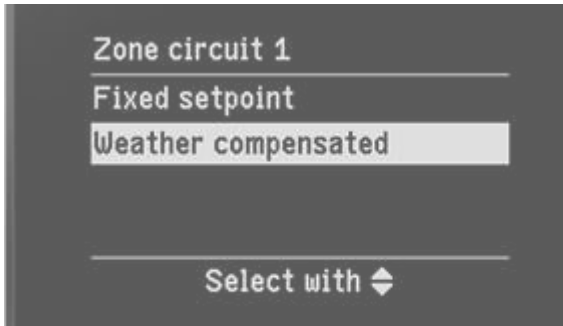

Select zone circuit type

Each zone circuit can be operated either as a fixed setpoint or weather compensated (using the outdoor temperature sensor) thermostat, use ▲/▼ to select and press OK.

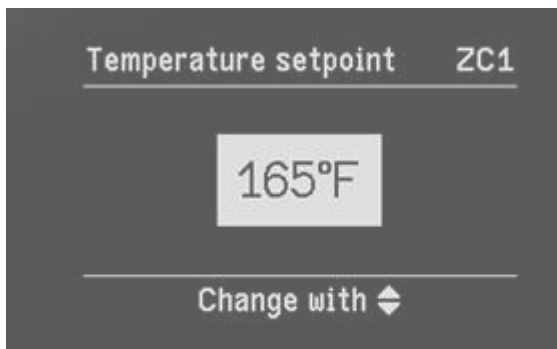

Select fixed setpoint

For zone circuits with fixed setpoint operation select desired supply water temperature use ▲/▼ to adjust and press OK.

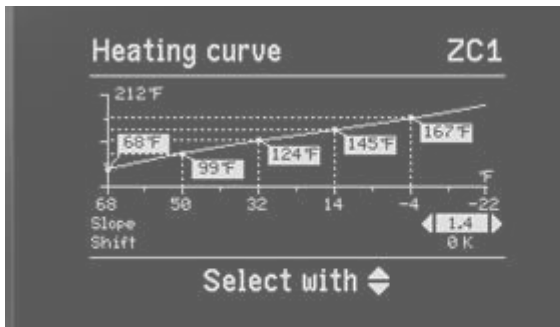

Adjust heating curve

Select between slope and shift with ▲/▼ and ►/◄ to adjust and press OK.

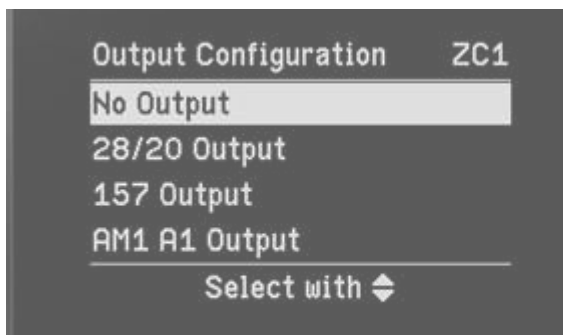

Select pump output

Assign desired pump output for zone circuit with ▲/▼ and press OK.

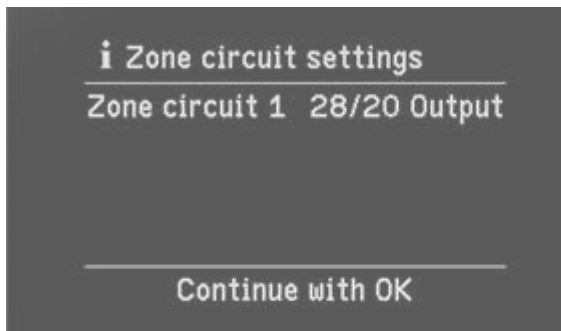
Start-up Wizard *(continued)***Confirm pump output**

Confirmation of selected pump output and press OK.

**Zone circuit temperature setting**

For the selected zone with fixed set point thermostat will display zone circuit temperature setting.

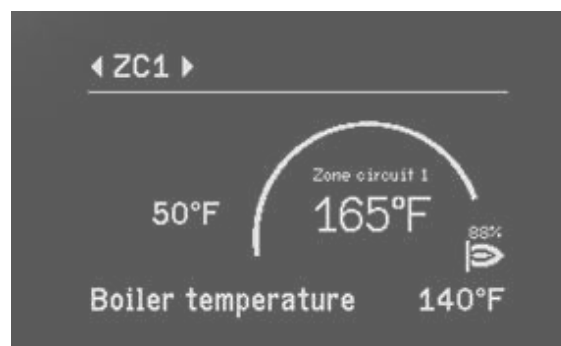
**Weather compensated operation**

For the selected zone circuit with weather compensated operation the current outdoor temperature and the current setpoint boiler temperature as calculated by the outdoor reset curve.

Making changes using the start-up wizard

In the event that an error has been made in the initial set-up of the start-up wizard or additional system components have been added to the system, the start-up wizard can be restarted at any time by;

1. Press OK and 'menu' simultaneously for approximately 4 sec.
2. "Service Functions"
3. "Set-up Wizard"
4. ▲/▼ to select 'Yes'
5. Press OK and the start-up wizard will restart

It is recommended the settings are recorded prior to restarting the start-up wizard as some settings may be reset during this process.

Removing Front Enclosure Panel

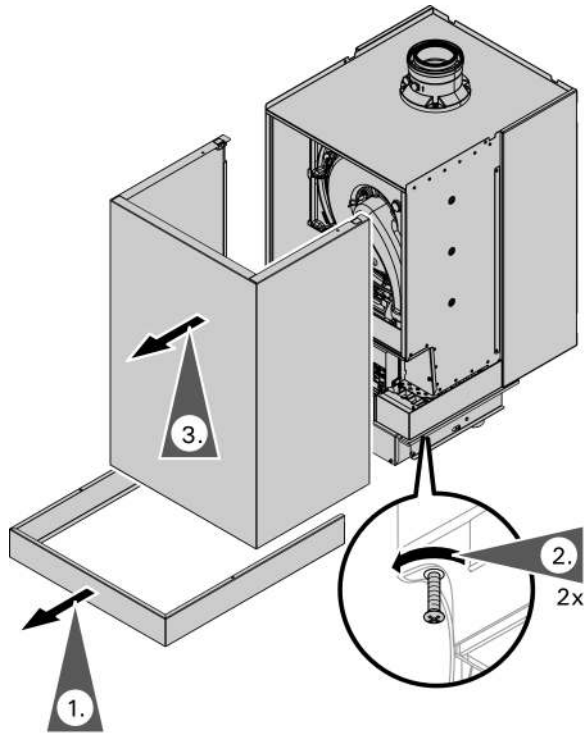

Some of the following service steps require the removal of the front enclosure panel. To avoid personal injury and/or product damage of any kind please follow the instructions below carefully when removing the front enclosure panel.

IMPORTANT

Close the main gas supply valve.

1. Remove the external accessories connection box cover.
2. Loosen the screws at the bottom of the boiler as shown (do not remove completely).
3. Slide out and remove front enclosure panel.

Fill Condensate Trap with Water

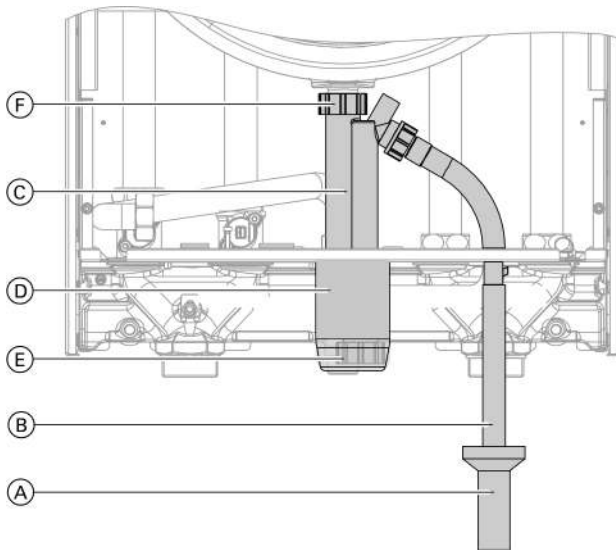

Filling the siphon with water

1. Undo union nut (F) and pull off condensate trap (C) downwards.
2. Fill condensate trap (C) with water.
3. Reinstall condensate trap (C) and reconnect union nut (F).

Legend

- (A) Open or vented field supplied drainage system
- (B) Flexible discharge tubing
- (C) Condensate trap
- (D) Rubber cap
- (E) Threaded cap
- (F) Union nut

Filling the Heating System with Water

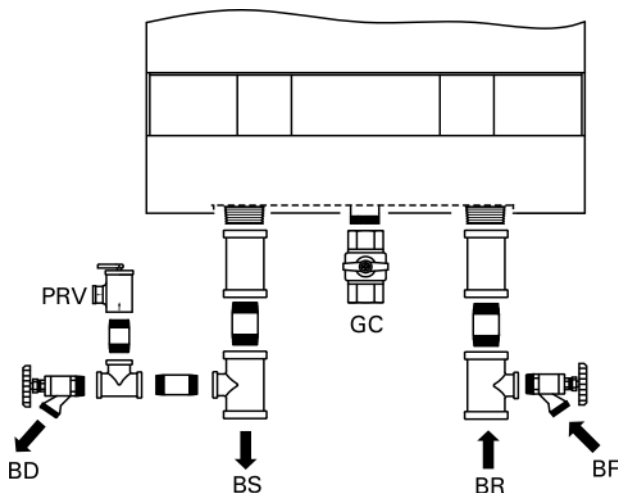

Legend

- BD Boiler Drain
- BF Boiler Fill
- BR Boiler Return
- BS Boiler Supply
- GC Gas Connection
- PRV Pressure Relief Valve

CAUTION

Unsuitable fill water increases the level of deposits and corrosion, and may lead to damage to the equipment.

- Thoroughly flush the entire heating system prior to filling with water.
- Only use water of potable quality.
- The water will have to be softened if it is harder than 8.77 grains / 150 ppm total dissolved solids.
- Inhibitors or antifreeze additives suitable for heating systems may be added manually.

1. Close gas shutoff valve.
2. Open system isolation valves at (if installed).
Note: Before filling the heating system with water, check that all necessary flow check valves are installed.
3. Check inlet pressure of the diaphragm expansion tank.
Note: If the nitrogen pressure of the precharged expansion tank is less than the static pressure of the system, inflate membrane pressure to slightly exceed pressure of system. The static pressure required at the tank is based upon the static height of the system. The system fill pressure value must be equal to the expansion tank pressure value at approximately 60°F (15.6°C).
4. To remove debris and/or sludge ensure that the system piping is flushed out. Failure to do so could cause settlement in the boiler causing overheating and damage not covered by warranty.
Note: System fill pressure must be approximately 3 psig higher than the static head when the system is cold.
5. Connect hose to boiler filling tap and other end to a fresh water supply (or heating medium).
6. Open fresh water supply valve and then the boiler filling tap slowly.
7. Fill the heating system with water at the boiler fill (BF) and fill the boiler until no more air comes out from the boiler drain (BD).
Note: Water treatment should be considered in areas where it is known that boiler feed water contains a high mineral content and hardness. In areas where freezing might occur, an antifreeze may be added to the system water to protect the system. Please adhere to the specifications given by the antifreeze manufacturer. Do not use automotive silicate-based antifreeze. Please observe that an antifreeze/water mixture may require a backflow preventer within the automatic water feed and influence components such as diaphragm expansion tanks, radiation, etc. A 40% antifreeze content will provide freeze-up protection to -10°F (-23°C). Do not use antifreeze other than specifically made for hot water heating systems. System also may contain components which might be negatively affected by antifreeze. Check total system frequently when filled with antifreeze.

Maximum operating pressure	80 psig
Minimum operating pressure.....	14 to 23 psig
Pressure relief valve.....	80 psig

Filling the Boiler Heat Exchanger

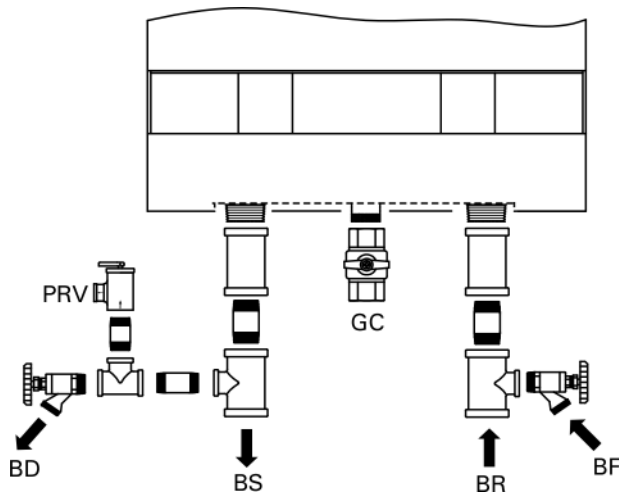



Legend

- BD Boiler Drain
- BF Boiler Fill
- BR Boiler Return
- BS Boiler Supply
- GC Gas Connection
- PRV Pressure Relief Valve

1. Close gas shutoff valve.
2. Connect hose to boiler filling tap and other end to a fresh water supply (or heating medium).
3. Connect another hose to the boiler drain and the other end to a drain.
4. Open fresh water supply valve and then the boiler filling tap slowly (system isolation valves must be closed during fill process).
5. when the discharge valve starts to discharge water without air bubbles, close Boiler drain valve, then boiler filling valve and open system shut-off valves.
6. Activate bleeding program (see next steps). Check the system pressure.
7. Activating the venting program:

Service menu

- Press OK and  simultaneously for approx. 4 sec.
 - "Service functions"
 - "Venting"
- Venting function is enabled.
Ending venting function:
- Press OK or .

8. - Check the system pressure.
- Release the air from the heating system
- Check the system pressure.
9. Remove the drain hose and the filling hose
10. Ensure an adequate fuel supply and open the gas Shut-off valve.

Designating Heating Circuits

In the delivered condition, the heating circuits are designated "Heating circuit 1", "Heating circuit 2" and "Heating circuit 3" (if installed).

If the system user prefers, the heating circuits can be designated differently to suit the specific system.

To enter names for heating circuits:



Refer to the Operating Instructions

Select Gas Type

Note: the Vitodens 200-W, B2HA boiler is factory set to operate with natural gas . See following subsection for conversion instructions to liquid propane gas.

1. Ensure that the fuel type listed on the boiler rating plate is the correct type for the installation being attempted.
2. Record fuel type in Maintenance Record on page 105.

The Vitodens 200-W boiler is for use with gases whose characteristics fall within the following ranges.

Do not use any other types of gas.

		Natural gas	Liquid propane gas
Heating value (gross)	Btu/ft ³	970 to 1100	2466 to 2542
Specific gravity		0.57 to 0.70	1.522 to 1.574
Ultimate carbon dioxide (CO ₂)	%	11.7 to 12.2	13.73 to 13.82

Convert Fuel Type to Liquid Propane Gas

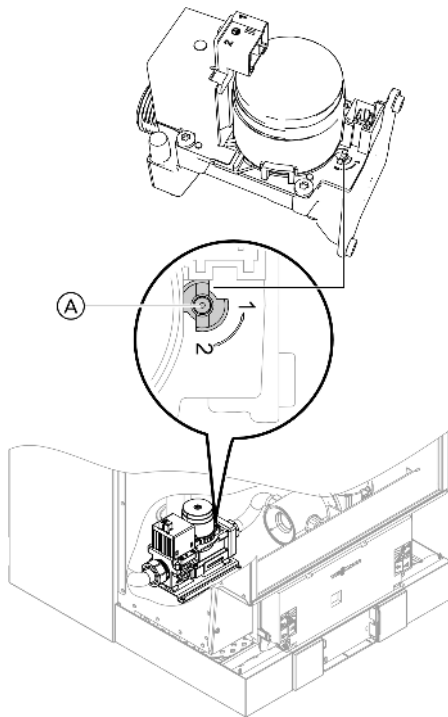

1. Set adjusting screw **(A)** at the gas valve to "2" (using a hex key, 2.5 mm).
Note: The Vitodens 200-W, B2HA boiler comes factory adjusted for operation with natural gas. Coding address "82" is set to "0" (operation with natural gas) in the factory default setting.
2. Switch ON/OFF switch **(D)** to ON.
Note: Slide the black control cover outwards to access the ON/OFF switch.
3. Call up coding level 2 (see page 45).
4. Call up "General".
5. In coding address "11" select value "9".
6. In coding address "82" select value "1" (operation with liquid propane gas).
7. Go back to coding address "11" and select any value (except "9").
8. Terminate coding level 2 and open gas shut-off valve.
9. Apply supplied fuel conversion labels.

Setting High Altitude

In the factory default setting, the boiler is equipped to operate in altitudes of up to 5,000 ft. (1,500 m).

Altitude can be set using coding address 93:
(in coding level 2 General).

- Coding 11:9 must be set in order to unlock coding 93:.
- 93:0 is reserved for altitudes up to 5000 ft. (1500 m).
- 93:6 must be set for altitudes from 5000 ft. (1500 m) to 10000 ft. (3000 m)
- Setting back to 93:0 turns off the high altitude function.

IMPORTANT

Do not set or use coding addresses 93:1 to 93:5.

- After setting coding address 93:, set coding address 11:0
- The program is automatically disabled after 20 minutes.

Measure Static Pressure and Running Pressure

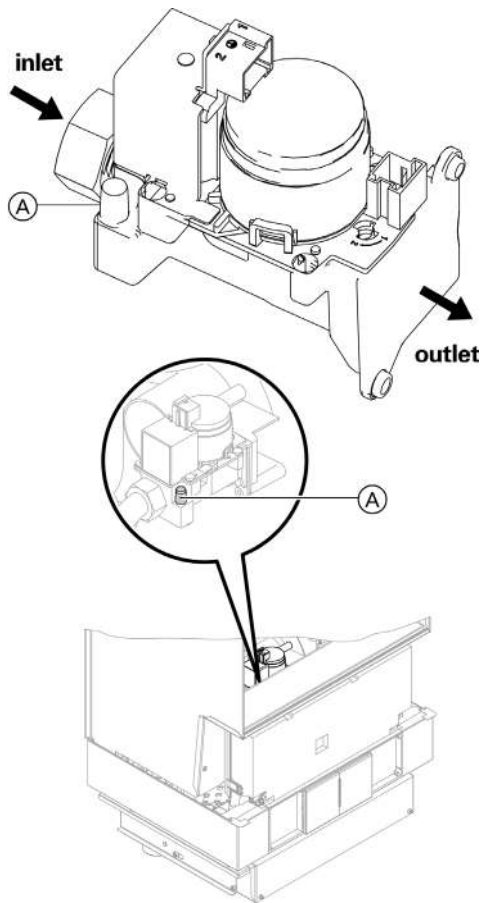

1. To measure static and/or running pressure remove boiler enclosure panel as indicated page 15 in these instructions.
2. Close gas shutoff valve.
3. Loosen screw at inlet gas pressure port (A) on the gas combination valve, do not remove completely. Connect manometer.
4. Open the gas shutoff valve.
5. Measure static pressure. Values must be:
14 "w.c. maximum for NG
14 "w.c. maximum for LPG
6. Enter measured value into Maintenance Record on page 105 in this manual.
7. Start up boiler, using the ON/OFF switch "ⓘ" on the boiler control.
Note: Slide the black control cover outwards to access the ON/OFF switch.
8. Measure the running pressure; value must be:
Note: Use suitable measuring instruments calibrated with a minimum resolution of 0.04 "w.c. for measuring the running pressure.

Running supply pressure with		Corrective action
NG	LPG	
under 4 "w.c.	under 10 "w.c.	Do not start the boiler. Notify your gas supply utility or LPG supplier.
4 to 14 "w.c.	10 to 14 "w.c.	Start up boiler.
over 14 "w.c.	over 14 "w.c.	Do not attempt adjustment. Call local gas utility to decrease pressure or install up stream gas pressure regulator. Boiler valve must not be exposed to pressure over 14 "w.c.

IMPORTANT

A CO measurement (see page 31) must be taken before and after working on gas appliances to eliminate risks to health and to guarantee the satisfactory condition of the system.

IMPORTANT

The burner is automatically ignited and starts operation after a safety time has elapsed. During initial start-up, the unit may indicate a fault because of air in the gas supply pipe (especially for liquid propane gas). After approx. 5 seconds, press the "R" button to reset the burner. The ignition procedure is repeated. This boiler employs a direct spark ignition system.



WARNING

Ensure that there is no open flame in the room.

9. Enter gas type into Maintenance Record on page 105 in this manual.
10. Switch off the ON/OFF switch "ⓘ" on the boiler control, close the gas shut-off valve, remove the manometer and re-tighten the screw at inlet gas pressure port (A).



WARNING

Never purge a gas line into a combustion chamber. Never use matches, candles, flame, or other sources of ignition for purpose of checking leakage. Use a soap and water solution to check for leakage. A failure to follow this warning could result in fire, explosion, personal injury or death.

Pressure Switches

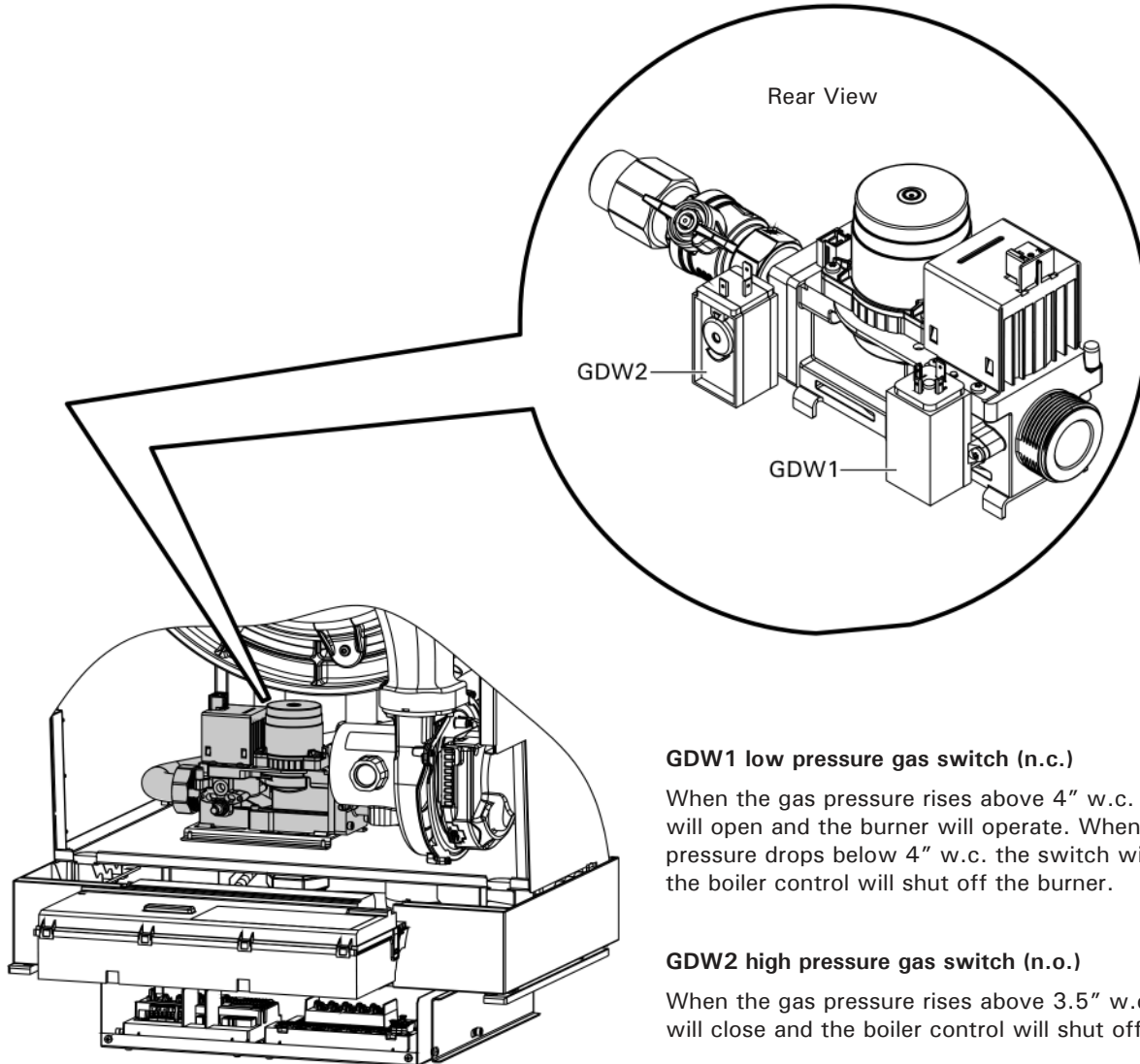

GDW1 low pressure gas switch (n.c.)

When the gas pressure rises above 4" w.c. the switch will open and the burner will operate. When the gas pressure drops below 4" w.c. the switch will close and the boiler control will shut off the burner.

GDW2 high pressure gas switch (n.o.)

When the gas pressure rises above 3.5" w.c. the switch will close and the boiler control will shut off the burner.

If either switch is activated (closed position) the burner will shut down, but no fault will be displayed on the control.

Check address 38 in coding 2, if the value is 2 then one of the switches has been activated (closed).

Sequence of Operation and Potential Faults During Each Start-up Cycle

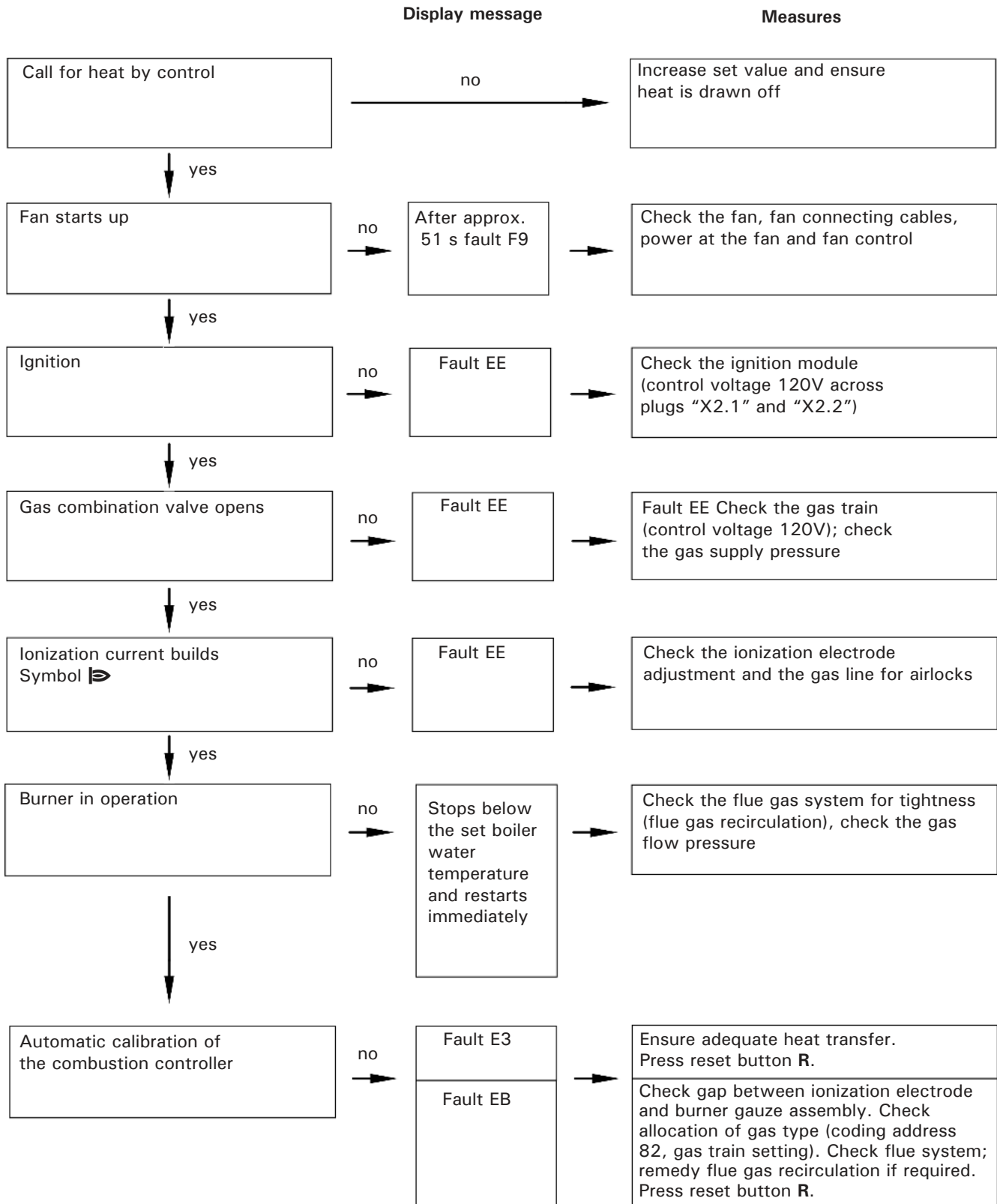

For further details regarding faults, see page 77.

Set Maximum Input

The maximum input (or output) for heating operation can be limited. The limit is set via the modulation range. The maximum adjustable heating input (or output) is limited upwards by the boiler coding card.

Note: The input for DHW production can be limited as well. To do so, change coding address "6F" in coding level 2.

1. Press OK and  simultaneously for approximately 4 seconds.
2. "Service functions"
3. "Maximum output"
4. "Change?" Select "Yes".
A value flashes on the display (e.g. "85"). In the factory setting, this value represents 100% of rated input (or output).
5. Select required value.

Check All Primary and Secondary Circuit Connections for Leaks

Check heating system and domestic hot water connections (if applicable). Ensure all connections are pressure tight. Correct any leaks found on fittings, pumps, valves, etc.

Perform Combustion Analysis

IMPORTANT

A CO measurement (see page 31) must be taken before and after working on gas appliances to eliminate risks to health and to guarantee the satisfactory condition of the system.

Record the measured combustion values in the sequence stated in the Maintenance Record on page 105 in this manual.

Check Coaxial Venting System for Leaks (circular air gap measurement)

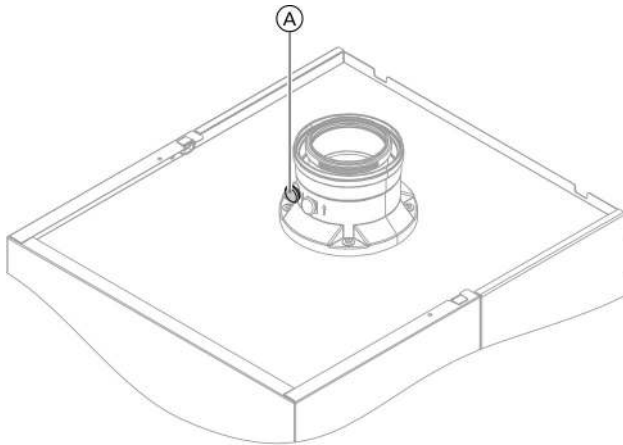

Viessmann strongly recommends that the heating contractor perform a simplified leak test during boiler start-up. For this purpose it is sufficient to measure the CO₂ concentration of the combustion air in the coaxial gap of the air intake pipe. The vent pipe is considered sufficiently leak-proof if a CO₂ concentration in the combustion air no higher than 0.2% or an O₂ concentration no lower than 20.6% is measured. If higher CO₂ values or lower O₂ values are measured, check venting system thoroughly.

Note: The vent pipe adaptor comes with two measurement ports, one for combustion air-intake measurement and one for flue gas measurement.

Remove Burner Assembly

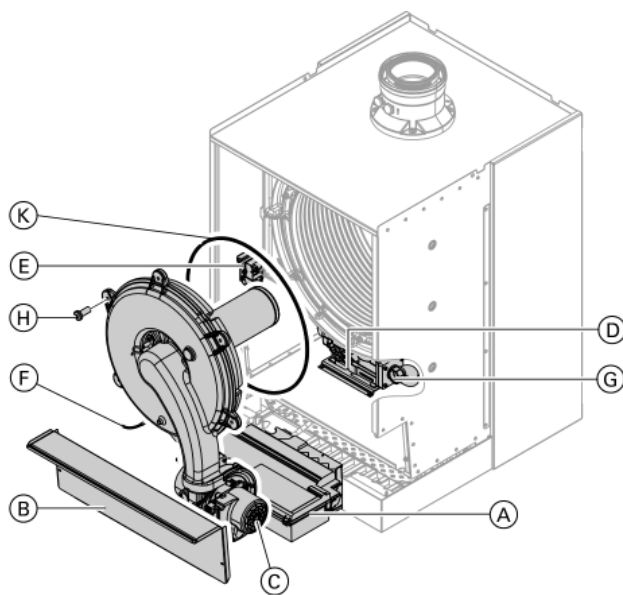

1. Switch the main power supply and the ON/OFF switch "ⓐ" on the boiler control to OFF.
Note: Slide the black control cover outwards to access the ON/OFF switch.
2. Shut off the gas valve.
3. Fold down control unit ⓐ and remove cover ⓑ.
4. Pull the cables from the fan motor ⓐ, gas valve ⓓ, ionization electrode ⓕ and ignition module ⓔ.
5. Release gas supply pipe fitting ⓖ.
Note: there is a gasket between the gas valve and the fitting.
6. Loosen the six Torx (T-30) screws ⓗ and remove burner.
7. Check burner gasket Ⓚ for damage. Generally replace the burner gasket every 2 years.

⚠ CAUTION

To avoid damage to the burner, do not lay burner on its cylindrical burner tube or touch the burner tube mesh. Failure to heed this caution may cause damage to the burner tube, which may lead to improper operation.

Reinstall Burner Assembly

IMPORTANT

Perform gas leak test.

1. Mount burner assembly and tighten screws in a diagonal pattern to a torque of 70 lb.in (8 Nm).
2. Fasten threaded connection for the gas line with a new gasket and torque to 132 lb.in (15 Nm).
3. Connect the electrical cables to the corresponding parts.

Checking the Flue Gas Flapper

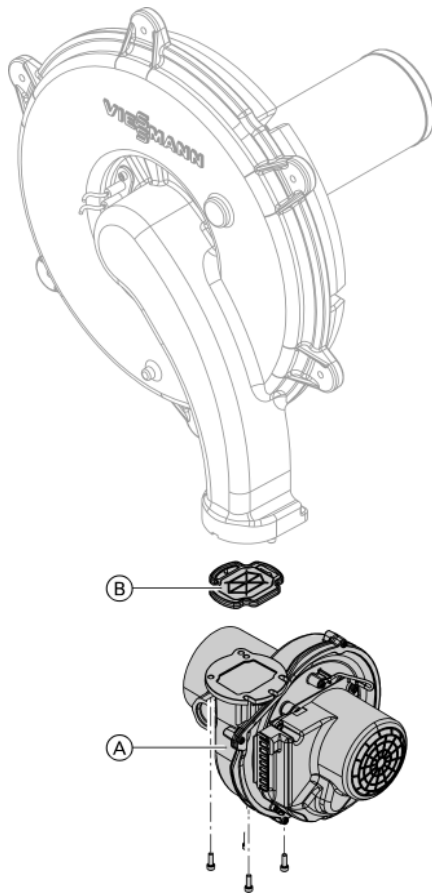

1. Undo three screws and remove fan (A).
2. Remove the flue gas flapper (B).
3. Check the flapper and gasket for dirt and damage. Replace as necessary.
4. Refit the flue gas flapper (B).
5. Refit fan (A) and secure with three screws. Torque: 2.2 lb.ft. (3.0 Nm).

Check Burner Refractory

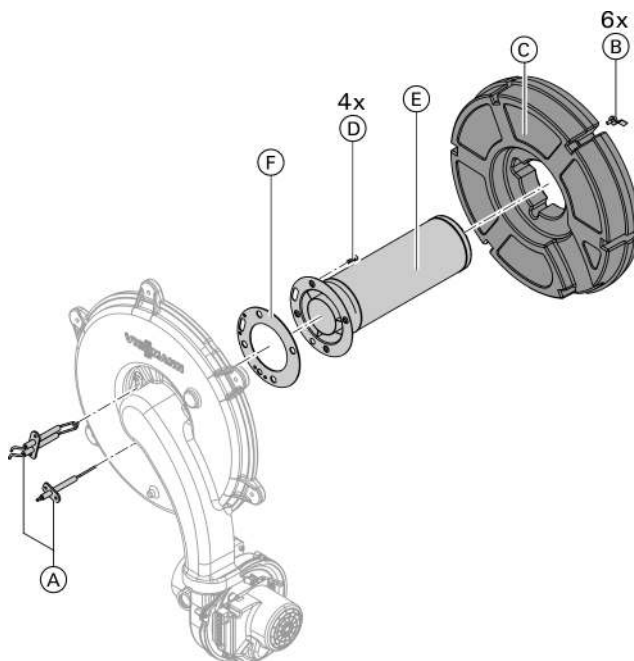

Check the burner refractory ring (C) and DHW tank burner assembly (E) for damage and replace if necessary.

1. Remove electrode block and ionization electrode (A).
2. Undo the three retaining clips (B) at the refractory ring (C) and remove refractory ring (C).
3. Loosen the four Torx screws (D) and remove DHW tank burner assembly (E) and assembly gasket (F).
4. Fit and secure new DHW tank burner assembly (E) and new assembly gasket (F). Tighten to a torque of 3.3 lb.ft. (4.5 Nm) using a calibrated torque wrench.
5. Reinstall refractory ring (C) and secure with retaining clip (B).
6. Reinstall electrode block and ionization electrode (A). Tighten to a torque of 3 lb.ft. (4 Nm) using a calibrated torque wrench.

Check and Adjust Ignition and Ionization Electrodes

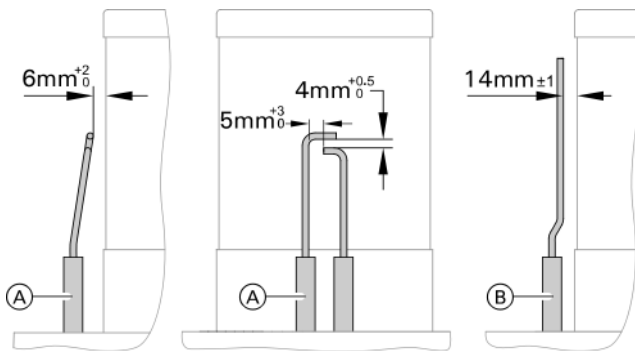

1. Check the ignition electrodes (A) and ionization electrode (B) for wear and contamination.
2. Clean electrodes with small brush (not a wire brush) or emery paper (cloth).
3. Check electrode gaps. If the gaps are not as specified, or the electrodes are damaged, replace and align the electrodes with new gaskets. Tighten the electrode fixing screws to a torque of 1.5 lb.ft. (2 Nm) using a calibrated torque wrench.

Clean Combustion Chamber/Heat Exchanger Surface

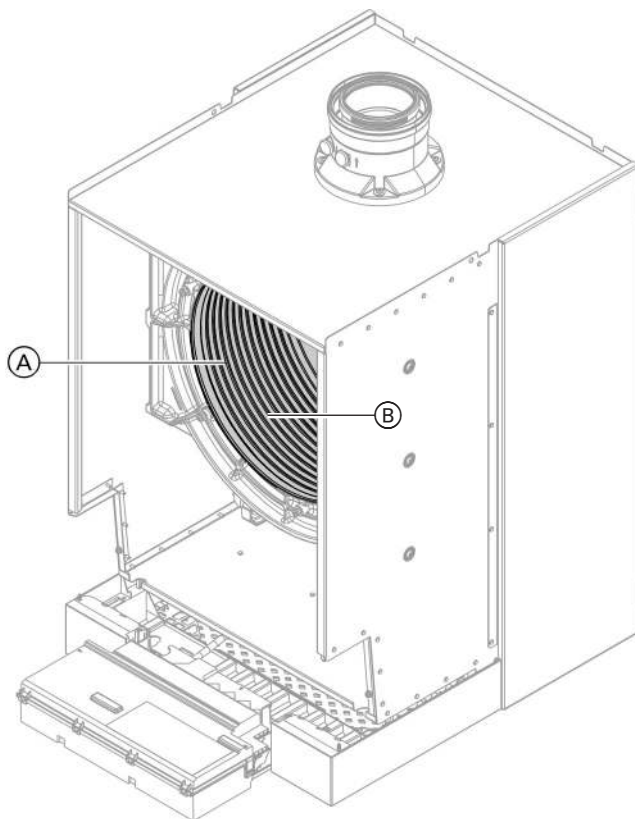

1. Remove burner assembly and reinstall upon completion of service work as per the instructions on page 24 in this manual.
2. Clean the combustion chamber (A) by vacuuming loose debris out.
3. Remove embedded sediment from the stainless steel heat exchanger surface (B) by thoroughly rinsing with water or cleaning agents such as Axiom Industries "Clean F Steel". Follow Axiom handling and application instructions when using cleaning agent.

Avoid getting the refractory wet during cleaning.

Note: Discoloration of the heat exchanger surface (B) is the normal result of the combustion process. It has no impact on the functionality or the longevity of the heat exchanger.

4. If the gaps between the heat exchanger coil windings are plugged, carefully remove debris without scratching the heat exchanger surface using the Viessmann tool specific for this purpose. Tool part number 7858492; Replacement blade part number 7840346.
5. Flush the combustion chamber (A) with water until it runs clear through the condensate trap.
6. Remove and clean out any accumulated debris from condensate trap. Reinstall condensate trap. See page 27 for details.

WARNING

Never use a metal wire brush or mechanically driven brushes.

WARNING

Follow cleaning agent manufacturer's safety instructions and wear appropriate protective equipment.

Check Condensate Drain

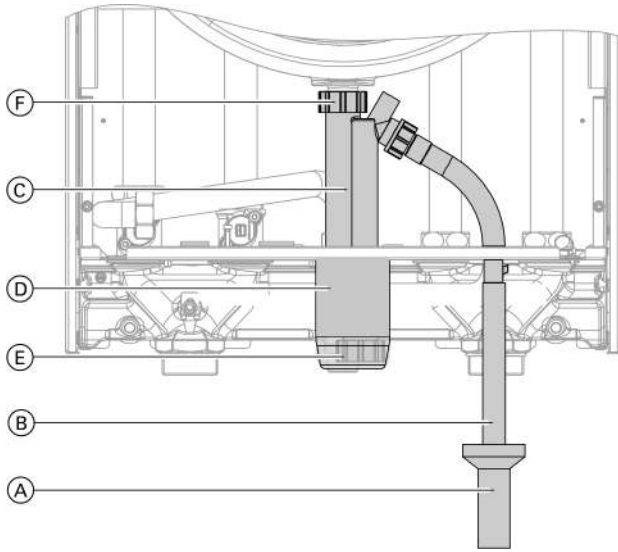

Legend

- (A) Open or vented field supplied drainage system
- (B) Flexible discharge tubing
- (C) Condensate trap
- (D) Rubber cap
- (E) Threaded cap
- (F) Union nut

Examples of condensate drain installation

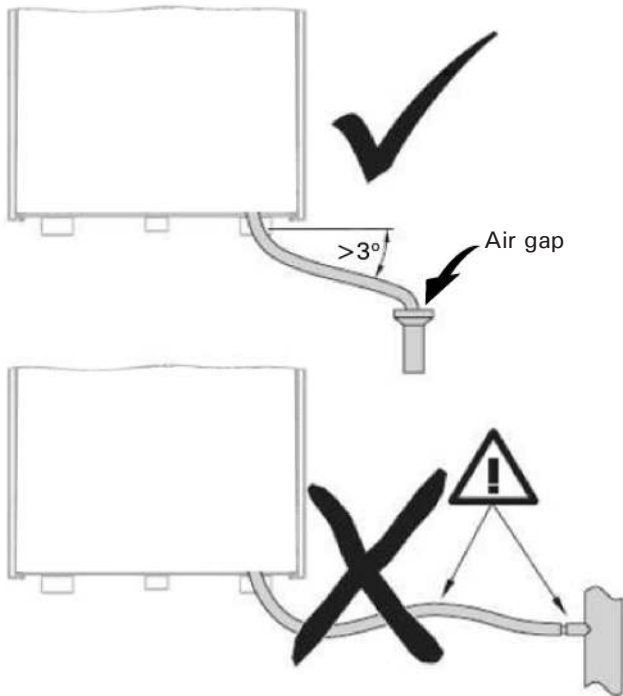

Cleaning condensate trap (during regular maintenance)

1. Remove rubber cap (D) from below the condensate trap.
2. Unscrew threaded cap (E) from the condensate trap (C).
Note: After unscrewing the threaded cap (E) it may be necessary to pry off to remove.
3. Clean out any debris from the condensate trap (C).
4. Reinstall threaded cap (E) and rubber cap (D).
5. Undo union nut (F) and pull off condensate trap (C) downwards.
6. Fill condensate trap (C) with water.
7. Reassemble in reverse order.

IMPORTANT

If the condensate does not drain freely, condensate will accumulate in bottom part of boiler resulting in a burner shut-down (fault message).

IMPORTANT

Pipe ventilation must take place between the condensate trap and the neutralization unit (if applicable).



Refer to Installation Instructions
Neutralization Unit (if applicable)

IMPORTANT

Do not connect the drain pipe from any other appliance, such as water softener backwash pipe, to Vitodens condensate drain pipe.

Check Neutralization Unit (if applicable)

1. Check the pH value of the condensate with pH measuring strip. If the pH value is less than 6.5, replace granulate.
2. If contaminated:
Rinse neutralization unit with tap water.
3. Add granulate as marked.



Refer to Installation Instructions
Neutralization Unit (if applicable)

IMPORTANT

pH measuring strip must be field supplied.

IMPORTANT

The granulate is consumed as it neutralizes the condensate. The red marking indicates the minimum filling level.

Check Diaphragm Expansion Tank and System Pressure

Perform check with the system cold.

1. Drain boiler/system and reduce pressure until the manometer reading is "0".
2. If the nitrogen pressure of the precharged expansion tank is less than the static pressure of the system, inflate membrane pressure to slightly exceed pressure of system.
The static pressure required at the tank is based upon the static height of the system. The system fill pressure value must be equal to the expansion tank pressure value at approximately 60°F (15.6°C).
Note: Static head of 33 ft. (10 m) (distance between boiler and topmost heat emitter surface) corresponds to a static pressure of 1 bar (15 psig).
3. Top up with water until filling pressure is higher than the inlet pressure of the diaphragm expansion tank.
Note: With the system cold, the filling pressure must be approximately 3 psig higher than the static pressure.
Maximum operating pressure: 80 psig
Minimum operating pressure: 14 psig
4. When starting up the system for the first time, mark this value as the minimum filling pressure on the manometer.
Note: A lower manometer reading usually indicates loss of water due to leakage. All leaks must be repaired.

Check Functioning of Safety Valves

Ensure proper operation of low water cut-off(s) (if applicable), pressure relief valve, and pump(s).

Check pressure gage, air vent and pressure relief valve. Ensure that pressure relief valve does not leak and that it operates in accordance with information provided by the manufacturer.



Refer to maintenance instructions supplied with low water cut-offs, pumps, etc.

Flush float water type low water cut-offs (if used).

Follow local regulations with respect to backflow preventers.

If oil-lubricated pumps are used, ensure proper lubrication.

If motorized zone valves are used, refer to maintenance instructions provided with zone valves.

Check Electrical Connections

Ensure all plug-in connectors and strain reliefs make positive contact and are seated properly.



Refer to the Installation Instructions

Check Gas Pipes and Fittings for Leaks



WARNING

The gas supply piping must be leak tested before placing the boiler in operation.



CAUTION

Ensure all joints of gas line are pressure tight and that gas valves do not leak when under normal operating pressure (use approved leak detection liquid).

Clock Natural Gas Meter

Clock natural gas meter to verify input.

1. Ensure all other gas equipment served by the meter is turned off during timing of gas input to the Vitodens 200-W, B2HA boiler.
2. Measure the time in seconds it takes for the boiler to use 10 ft.³ of gas. Divide 3600 x 10 by the number of seconds and you get the number of ft.³ of gas used per hour. Multiply this number by the heating value of the gas to obtain Btu per hour input.

For example:

A Vitodens 200-W, B2HA 530 boiler (530000 Btu/h input) requires 68 sec. to use 10 ft.³ of natural gas. After contacting the local utility, you will find the heating value is 1000 Btu per ft.³.

Therefore:

3,600 sec./h x 10 revolutions
 36,000/68 x 1000 = 530000 Btu/h input.
 The boiler input is correct.

Burner input formulas (for low altitude only):

INPUT = (3600t) x 1000 where
 t = TIME (sec.) for 1 ft.³
 INPUT = (3600 x .01 x 1000 x 35.31)T where
 T = TIME (sec.) for .01 m³ natural gas

IMPORTANT

A boiler underfired by 5% is acceptable. Do not overfire the boiler.

CAUTION



Always contact your gas utility to obtain the correct heating value before clocking the meter.

Check CO₂ Setting

The Vitodens 200-W, B2HA boiler is equipped with the Combustion Management System developed by Viessmann which ensures optimal combustion quality independent of gas quality and type. (For a description of the Combustion Management System, see page 34 in this manual). During initial start-up and maintenance you will only need to check the CO₂ and O₂ content at the boiler vent pipe adaptor.

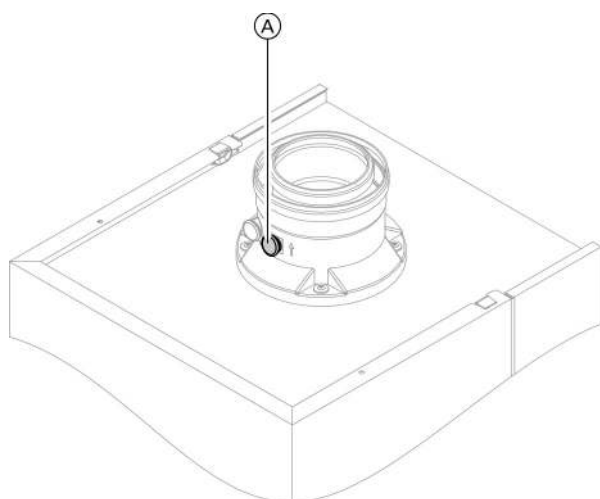
Note: The Vitodens 200-W, B2HA boiler comes factory set to operation with natural gas. (For instructions on how to convert to operation with liquid propane gas, see page 19). For high-altitude operation above 5,000 ft. (1,500 m), see page 19. The MatriX cylinder burner of this boiler is preset for the entire gas group. No adjustment or readjustment of the burner is required.



1. Connect a flue gas analyzer to test port (A) at boiler vent pipe adaptor.
2. Open gas shut-off valve, start up boiler and create heat demand.
3. Selecting low/high fire:
Service menu
- Press OK and  simultaneously for approximately 4 seconds.
- "Actuator test"
- Selecting low fire: select "Base load OFF". Then "Base load ON" appears and the burner operates in low fire.
4. Measure CO₂ and O₂ content at boiler vent pipe adaptor. If the measured values deviated by more than 1% from the ranges for the respective fuel type listed in the right column or in the table on page 34.
 - check the venting system for leaks (see subsection on page 24).
 - check that the boiler is set for the gas type used (see subsection on page 19).
 CO₂ content range:
 - 7.5 to 10.5% for natural gas
 - 9.0 to 11.3% for LPG
 O₂ content range:
 - 3.8 to 7.3% for all gas types
5. Enter measured values into the Maintenance Record on page 105. Terminate by selecting 'all actuators off'.
6. Selecting high fire: select "Full load OFF". Then "Full load ON" appears and the burner operates in high fire.
7. Measure CO₂ and O₂ content at boiler vent pipe adaptor. If the measured values deviated by more than 1% from the ranges listed in the right column or in the table on page 34.
 - check the venting system for leaks (see subsection on page 24).
 - check that the boiler is set for the gas type used (see subsection on page 19).
 CO₂ content range:
 - 7.5 to 10.5% for natural gas
 - 9.0 to 11.3% for LPG
 O₂ content range:
 - 3.8 to 7.3% for all gas types
8. Press  to exit actuator test after testing and enter measured values into the Maintenance Record on page 105.

Start-up and Shutdown



Legend

- (A) Fault indicator (red)
- (B) ON indicator (green)
- (C) Reset button
- (D) ON/OFF switch
- (E) Pressure gauge

Starting the heating system

1. Check the heating system pressure at the pressure gauge. The heating system pressure is too low if the indicator points to the area below 15 psi. In this case, top up with water or notify your local heating contractor.
2. For room air dependent operation: Check that the ventilation apertures of the installation room are open and unrestricted.

Note: With room air dependent operation, the combustion air is drawn from the boiler room.
3. For Vitodens: Open the gas shut-off valve.

Note: Ask your heating contractor to explain the positioning and handling of these components.
4. Switch ON the power supply, e.g. at a separate power switch or fuse.
5. Turn the ON/OFF switch "ⓓ" ON. After a short time, the standard menu is displayed and the green ON indicator illuminates. Your heating system and, if installed, your remote controls are now ready for operation.

Note: Slide the black control cover outwards to access the ON/OFF switch.

Menu

There are two control levels available, the "Standard menu" and the "Extended menu".

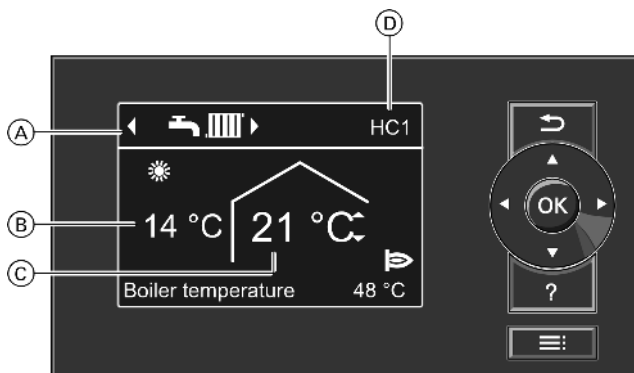

Heating circuit interface

Legend

- (A) Header (shows the heating program for displayed heating circuit ⓓ)
- (B) Current outside temperature
- (C) Set room temperature
- (D) Heating circuit which is selected for operation in the standard menu

Standard menu

Note: If your heating system has 2 or 3 heating circuits or zone circuits

You can select the heating circuit "HC1", "HC2" "HC3" "ZC1", "ZC2" or "ZC3" to be displayed in the standard menu.

If your heating system only has 1 heating circuit: No heating circuit name "HC..." is shown in the header.

In the standard menu, you can adjust and scan the most frequently used settings for the heating circuit shown in the header:

Press the following keys to set room temperature:

▲/▼ for the required value

OK to confirm

Heating programs:

⏻ Standby mode with frost protection monitoring

☀ Only DHW

🔥 Heating and DHW

Press the following keys:

▶/◀ for the required heating program

OK to confirm

Note: 2 minutes after any setting has been made, the display automatically reverts to the standard menu.

Menu *(continued)*

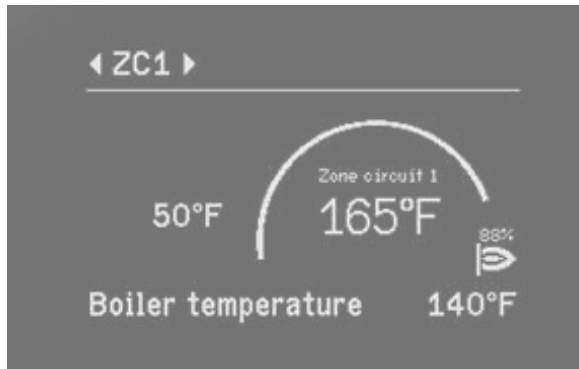

Zone control interface

Note: For any other connected heating circuits, use the settings in the extended menu.
 Call up the standard menu as follows:
 - If the screen saver is active
 - Press any key except ?.
 If you are somewhere in the menu:
 Keep pressing ↵ until the standard menu appears.

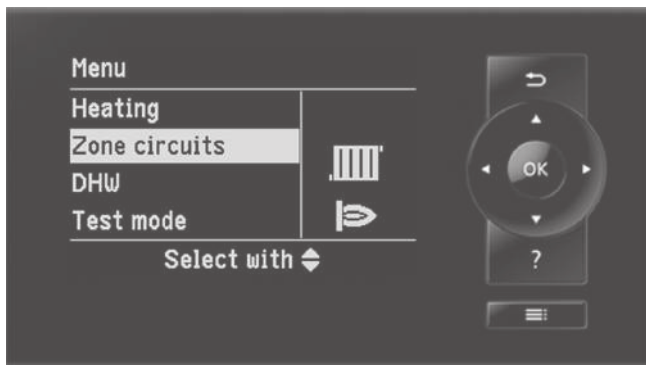

Symbols on the display

These symbols are not always displayed, but appear subject to the system version and the operating state.

Heating programs

- ☾ Standby mode with frost protection monitoring
- 🔥 Only DHW
- 🔥 III Heating and DHW

Displays

HC1 (2, 3) To display the heating circuit selected in the standard menu

To change this, see page 32

- ☁ Frost protection monitoring
- ☀ Central heating with standard temperature
- ☾ Central heating with reduced temperature
- 👤 Party mode enabled
- 🌱 Economy mode enabled

In conjunction with a solar thermal system

- ☀ Solar circuit pump running
- 🔥 Burner in operation

Messages

- 🔧 Service message
- ⚠ Fault message

Extended menu

In the extended menu, you can adjust and scan the settings from the control unit's range of functions used less frequently, (e.g. time programs and holiday programs). The menu overview can be found on page 32.

Call up the extended menu

If the screen saver is active:

Press any key except ?, and then press ≡.

If you are somewhere in the menu:

Press ≡.

How to use the controls

The screen saver will become active if you have not adjusted any settings on the programming unit for a few minutes. The display brightness is reduced.

Zone Circuit Display

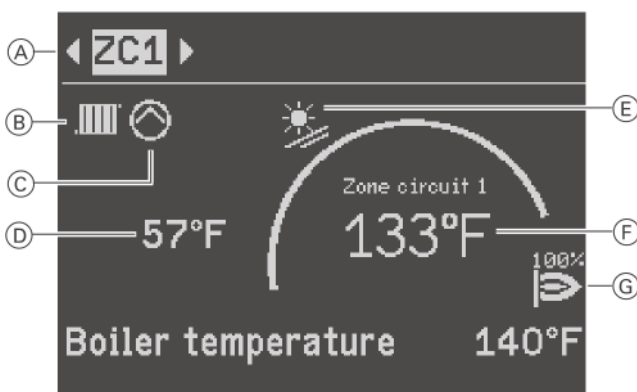

Legend

- Ⓐ Header zone circuit which is selected for operation in the standard menu.
- Ⓑ Heating
- Ⓒ Zone circuit pump output active
- Ⓓ Current outdoor temperature. Only for zone circuits with weather compensated operation.
- Ⓔ In conjunction with solar thermal system: Solar circuit pump running
- Ⓕ Set zone circuit temperature
- Ⓖ Burner in operation with modulation rate in %.

Functional Description

Space heating mode

The control unit calculates a boiler water setpoint temperature based on the outdoor or room temperature (where a room temperature dependent remote control is connected) and on the slope/shift of the heating curve. The computed boiler water setpoint temperature is transmitted to the burner control unit.

For zone circuit operation the boiler water temperature is calculated based on the slope/shift of the heating curve or programmed boiler water temperature setpoint. The boiler runs only when a signal has been received from a connected room thermostat (dry contact).

From the boiler water setpoint and the actual temperature the burner control calculates the degree of modulation required, and regulates the burner accordingly. The maximum operating boiler water temperature is limited in the burner control unit to 185°F (85°C) by the electronic temperature control. The fixed high limits of the safety chain interlock the burner control unit at 210°F (99°C) boiler water temperature.

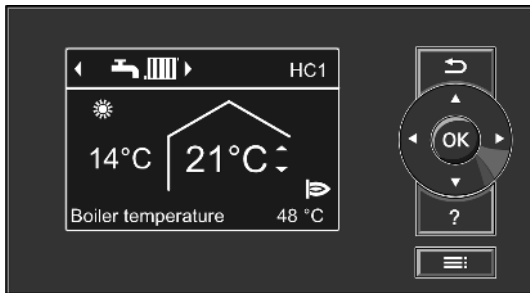

Domestic hot water supply with gas-fired space heating boiler

Domestic hot water heating is activated when the tank temperature is 4.5°F (2.5°C) below the tank temperature setpoint value. The burner and the tank DHW pump are switched on. In the factory default setting, the desired boiler water temperature is set at 36°F (20°C) above the tank temperature setpoint value. When the actual tank temperature rises 4.5°F (2.5°C) above the tank temperature setpoint value, the burner is switched off and the time delay function of the tank DHW pump is activated.

The temperature differential of 4.5°F (2.5°C) can be adjusted in coding level 2, address "59" DHW boost heating / additional heating function. This function will heat your DHW tank to a second DHW setpoint temperature within the fourth time phase. It can act as an "Anti-Legionnaire-Function" if the DHW supply is not heated to 140°F (60°C) during the regular time schedule.

You can activate this function by selecting a switching period for the fourth time phase. (See Vitodens 200-W, B2HA Operating Instructions.)

The temperature setpoint for this function is adjustable in coding address "58".

Combustion Management System

The combustion management system utilizes the physical correlation between the level of the ionization current and the air factor λ . For all gas qualities, the maximum ionization current results with air factor λ .

The ionization signal is evaluated by the combustion management system, and the air factor is adjusted to between $\lambda = 1.24$ and 1.44 . This range provides for an optimum combustion quality. Thereafter, the electronic gas valve regulates the required gas volume based on the prevailing gas quality.

To check the combustion quality, the CO₂ content or the O₂ content of the flue gas is measured. The actual values enable the prevailing air factor to be determined. The relationship between the CO₂ or O₂ content and air factor λ is illustrated in the table below.

To achieve an optimum combustion control, the system regularly performs an automatic self-calibration; also after a power failure (shutdown). For this, the combustion is briefly regulated to max. ionization current (equals air factor $\lambda = 1$). The automatic calibration is performed shortly after the burner starts and lasts approximately 5 seconds.

During the calibration, higher than normal CO emissions may occur briefly.

Air factor λ - CO₂/O₂ content

Air factor λ	O ₂ content (%)	CO ₂ content (%) for natural gas	CO ₂ content (%) for liquid propane gas
1.20	3.8	9.6	11.3
1.24	4.4	9.2	10.9
1.27	4.9	9.0	10.6
1.30	5.3	8.7	10.3
1.34	5.7	8.5	10.0
1.37	6.1	8.3	9.8
1.40	6.5	8.1	9.6
1.44	6.9	7.8	9.3
1.48	7.3	7.6	9.0

The Vitodens 200-W, B2HA boilers come equipped with Lambda Pro, the industry's first intelligent combustion management system.

Installation Examples

System type 1

System Examples for codes 00:1 and 00:2

Heating system with one heating circuit without mixing valve A1 with/without DHW heating, with/without low loss header.

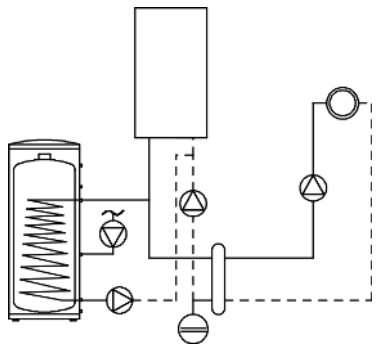
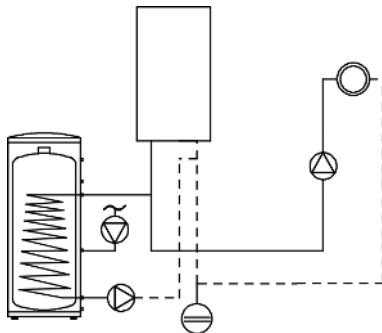

Matching the control unit to the heating system

The control unit must be matched to the equipment level of the system. Various system components are recognized automatically by the control unit and the relevant codes are adjusted automatically.

- For the selection of an appropriate type, see the following diagrams.
- For coding steps, starting on page 44.

Function/system components	Code	
	Adjust	Group
One heating circuit without mixing valve A1 (heating circuit 1), without DHW heating	00:1	General/1
One heating circuit without mixing valve A1 (heating circuit 1), with DHW heating (code is adjusted automatically)	00:2	General/1
System with low loss header	04:0	Boiler/2

Installation Examples *(continued)*

System type 2

System Examples for codes 00:3 and 00:4

Heating system with one heating circuit with mixing valve M2 with system separation, with/without DHW heating, with/without low loss header.

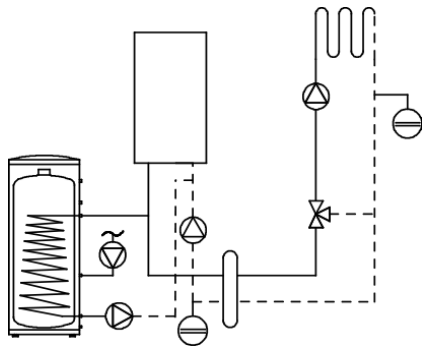
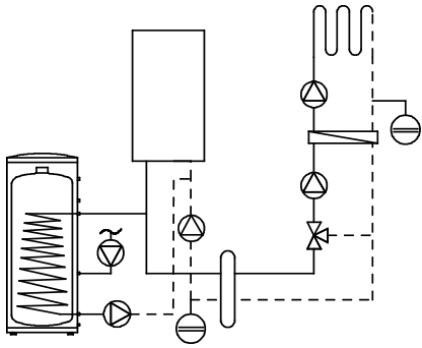

Function/system components	Code	
	Adjust	Group
Heating system with one heating circuit without mixing valve, with/without domestic hot water heating		General/1
- without DHW tank	00:3	
- with DHW tank	00:4	
System with low loss header	04:0	Boiler/2

Installation Examples *(continued)*

System type 3

System Examples for code 00:5 and 00:6

Heating system with one heating circuit without mixing valve, one heating circuit with mixing valve, one heating circuit with mixing valve and system separation, with/without domestic hot water heating (with and without low loss header).

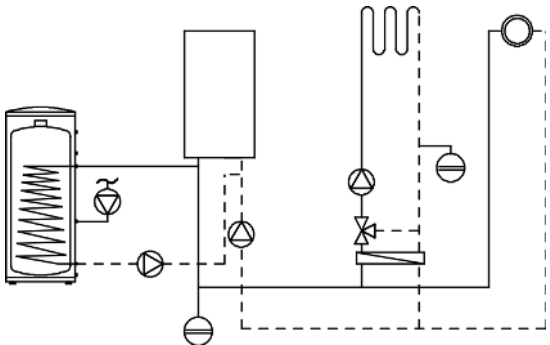
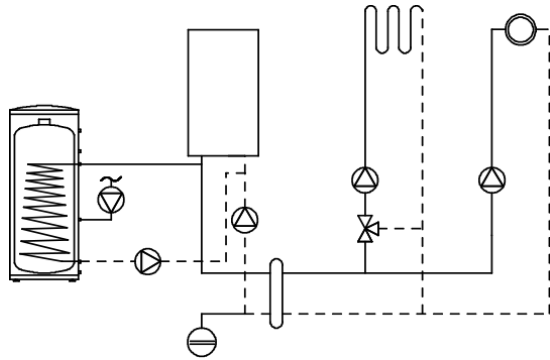
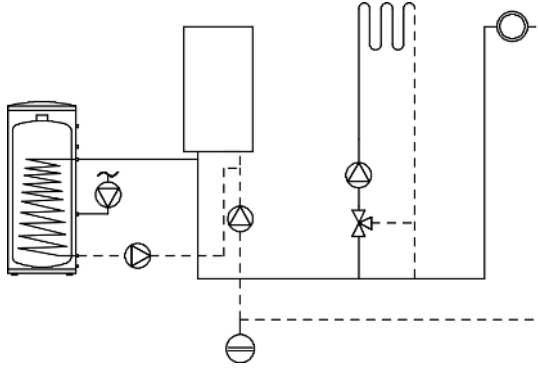

Function/system components	Code	
	Adjust	Group
System with one heating circuit without mixing valve A1 (heating circuit 1) and one heating circuit with mixing valve M2 (heating circuit 2), (code is adjusted automatically)		General/1
- without DHW heating	00:5	
- with DHW heating	00:6	
System with low loss header	04:0	Boiler/2

Installation Examples *(continued)*

System type 4

System Example for code 00:7 and 00:8

Heating system with one heating circuit with mixing valve, one heating circuit with mixing valve M2 (with extension kit), one heating circuit with mixing valve M3 (with extension kit) and low loss header (with/without DHW heating).

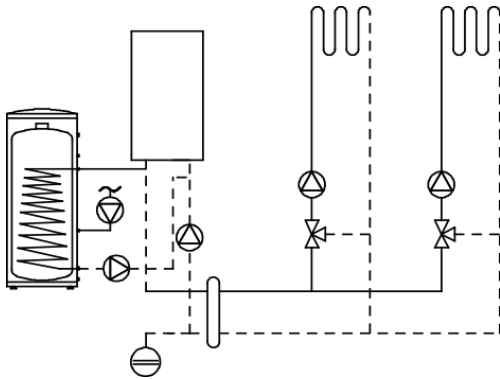

Function/system components	Code	
	Adjust	Group
System only with two heating circuits with mixing valve with extension kit for mixing valve (without unregulated heating circuit)		General/1
- with DHW tank	00:8	
- without DHW tank	00:7	
System with low loss header	04:0	Boiler/2

System type 5

System Example for code 00:9 and 00:10

Heating system with one heating circuit with mixing valve, one heating circuit with mixing valve M2 (with extension kit), one heating circuit with mixing valve M3 (with extension kit) and low loss header (with/without DHW heating).

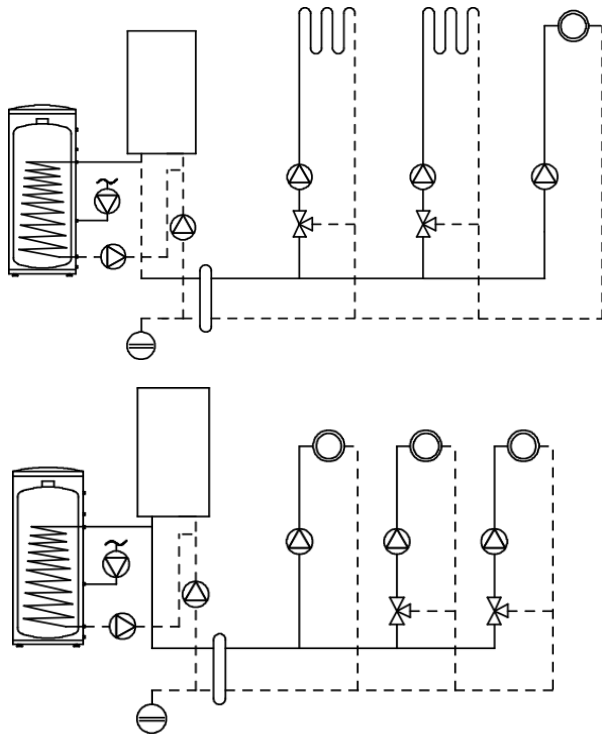

Function/system components	Code	
	Adjust	Group
System with one heating circuit without mixing valve A1 (heating circuit 1), one heating circuit with mixing valve M2 (heating circuit 2) and one heating circuit with mixing valve M3 (heating circuit 3), without DHW heating (code is adjusted automatically)		General/1
- without DHW tank	00:9	
- with DHW tank	00:10	
System with low loss header	04:0	Boiler/2

Installation Examples *(continued)*

System type 6

Heating system with three zone circuits (thermostat operated).

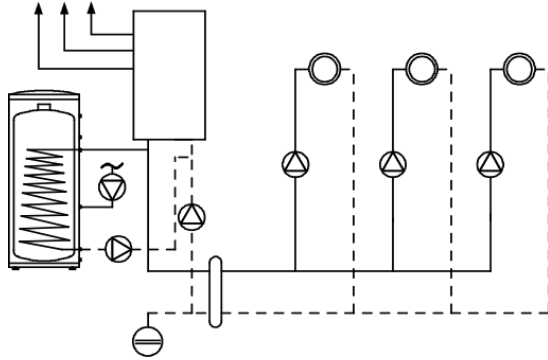

Function/system components	Code	
	Adjust	Group
Zone circuit 1 A1 (AM1)	33:5	General/2
Zone circuit 2 A2 (AM1)	34:6	
Zone circuit 3 output 157 at extension EA1	36:8	
System with low loss header	04:0	Boiler/2

Function / System components	Code	
	General 2	
Zone circuit 1		
Constant	3A:7	
Weather compensate	3A:8	
Zone circuit 2		
Constant	3B:7	
Weather compensate	3B:8	
Zone circuit 3		
Constant	3C:7	
Weather compensate	3C:8	

System Example for multiple boilers

Multi boiler system with several heating circuits with mixing valve and low loss header (with/without DHW heating)

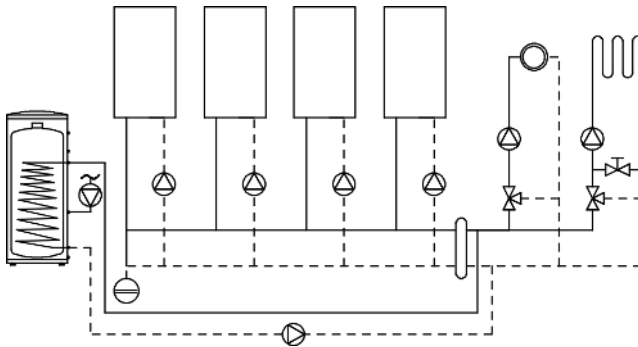

Function/system components	Code	
	Adjust	Group
Multi boiler system with Vitotronic 300-K, MW2C control	01:2	General/1
System with low loss header	04:0	Boiler/2

Note: Codes for multi boiler system, see Vitotronic 300-K, MW2C control Service Instructions.

The heating curves represent the relationship between the outdoor temperature and the boiler water or supply temperature.

Put simply: The lower the outdoor temperature, the higher the boiler water or supply temperature.

In turn, the room temperature is dependent on the boiler water or supply temperature.

If a different room temperature is set, the curves are shifted parallel to the desired room temperature axis.

The control unit regulates the boiler water temperature (= supply temperature of heating circuit without mixing valve) and the supply temperature of the heating circuit with mixing valve (in conjunction with the accessory kit for a heating circuit with mixing valve) according to the outdoor temperature. The boiler water temperature is automatically raised by 0 to 72 F / 0 to 40 K higher than the currently required set supply temperature (in the factory default setting the differential temperature is 14.4 F / 8 K). See coding address "9F" in General Group.

The supply temperature that is required to achieve a given room temperature depends on the heating system and the thermal insulation of the building that is being heated.

The adjustment of the two heating curves is used to match the boiler water temperature and the supply temperature to these conditions. The boiler water temperature is limited upwards by the fixed high limit and the temperature set for the electronic high limit.

The supply temperature cannot rise above the boiler water temperature.

Factory settings:

- slope = 1.4
- shift = 0

Note: If the heating system includes heating circuits with mixing valves, then the flow temperature of the heating circuit without mixing valve is higher by a selected differential (8 K in the factory setting) than the flow temperature of the heating circuits with mixing valves. The differential temperature can be changed at coding address 9F.

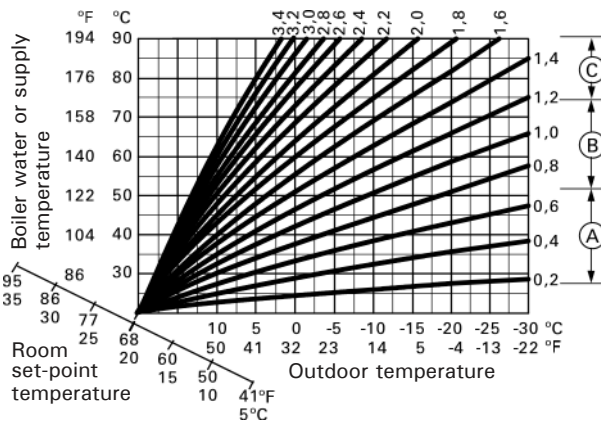

Legend

- (A) Low-temperature heating system, e.g. radiant floor heating, 0.2 - 0.7
- (B) Medium-temperature heating system, e.g. cast iron radiation, panel radiant floor heating, 0.7 - 1.2
- (C) High-temperature heating system, e.g. fintube radiation, fan coils, 1.2 - 1.5

Heating Curve Adjustment *(continued)*

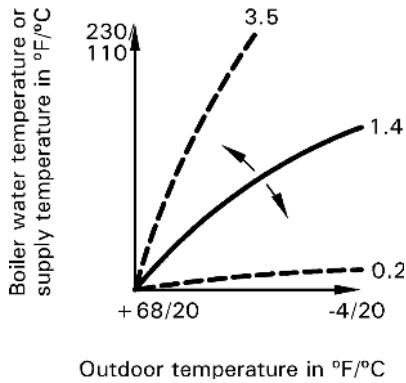

Changing the slope and level

Extended menu:

- 1.
2. Select "Heating" - **OK**
3. Heating circuit selection
4. Accept with **OK**
5. Heating curve - **OK**
6. Slope or level - **OK**
7. Change with
8. Select heating curve according to the system requirements.
9. Exit

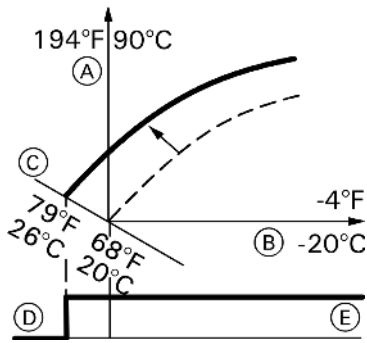

Standard Room Temperature

- 1.
2. Select "Heating"
3. Heating circuit selection
4. **OK**
5. Room temperature setpoint - **OK**
6. Change with
7. Accept with **OK**
- 8.

Example 1: Adjusting the room temperature setpoint from 68° F to 79° F (20° C to 26° C)



Refer to the Operating Instructions

Legend

- (A) Boiler water temperature / Supply temperature
- (B) Outdoor temperature
- (C) Room temperature setpoint
- (D) Heating circuit pump "OFF"
- (E) Heating circuit pump "ON"

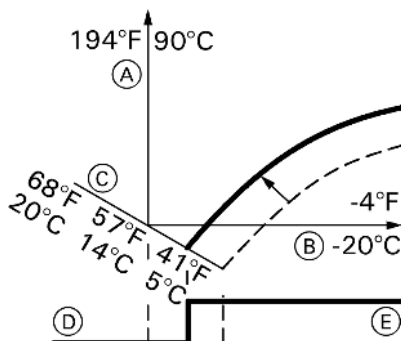

Room Temperature Setback

- 1.
2. Select "Heating"
3. Heating circuit selection
4. **OK**
5. Red room temperature setpoint - **OK**
6. Change with
7. Accept with **OK**
- 8.

Example 2: Adjusting the room temperature setback from 41° F to 57° F (5° C to 14° C)



Refer to the Operating Instructions.

Legend

- (A) Boiler water temperature / Supply temperature
- (B) Outdoor temperature
- (C) Room temperature setpoint
- (D) Heating circuit pump "OFF"
- (E) Heating circuit pump "ON"

5683 710 -34

Connecting the Boiler Control to a LON System

Updating the LON participant list

Only possible if all participants are connected and the control unit is programmed to be fault manager (coding address "79:1").

Performing a LON participant check

Communication with the system devices connected to the fault manager is tested by means of a participant check.

Preconditions:

- The control unit must be programmed as fault manager (code "79:1")
- The LON participant number must be programmed in all control units (see page 43)
- The LON participant list in the fault manager must be up to date

Performing the participant check:

1. Press OK and  simultaneously for approximately 4 seconds
2. "Service functions"
3. "Participant check"
4. Select participant (e.g. participant 10).

The participant check for the selected participant is initiated.

- Successfully tested participants are designated with "OK".
- Unsuccessfully tested participants are designated with "Not OK".

Note: To carry out a new participant check, create a new participant list with menu item "Delete list?"

Note: If the participant check is carried out by another control unit, the participant number and "Wink" are shown on the display for approximately 1 minute.

Scanning and resetting the "Service" display

After the limits specified in coding addresses "21" and "23" have been reached, the red fault indicator flashes and the following appears on the programming unit display:

- "Service" and 

Scanning and resetting service

Press **OK** to acknowledge a service message.

Note: An acknowledged service message that was not reset reappears:

- On the following Monday.

After a service has been carried out (reset service):

1. Press OK and  simultaneously for approximately 4 seconds.
2. "Service functions"
3. "Service reset"

Note: The selected service parameters for hours run and time interval restart at 0.

Instructing the system user

The system installer must hand the operating instructions to the system user and instruct the user in the operation of the system.

Connecting the Boiler Control to a LON System *(continued)*

The LON communication module (accessory) must be connected.

Note: The data transfer via the LON can take several minutes.

Single boiler system with Vitotronic 200-H, HK1B and Vitotronic 200-H, HK3B mixing valve controls and Vitocom LON communication module

Set the LON participant numbers and other functions via coding level 2 (see table below)

Note: In the same LON system, the same participant number cannot be allocated twice. Only one Vitotronic may be programmed as fault manager.

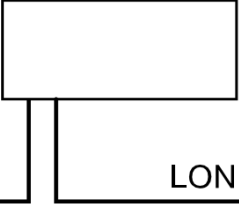
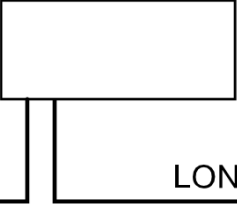
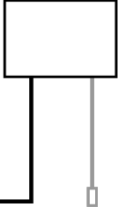

Refer to the Installation Instructions for the LON communication module

Boiler control unit	Vitotronic 200-H (e.g. HK1B mixing valve control)	Vitotronic 200-H (e.g. HK3B *1 multiple mixing valve control)	Vitocom *1 LON communication module
			
Participant no. 1 Code "77:1"	Participant no. 10 Code "77:10"	Participant no. 11 Set code "77:11"	Participant no. 99
Control unit is fault manager Code "79:1"	Control unit is not fault manager Code "79:0"	Control unit is not fault manager Code "79:0"	Device is fault manager
Control unit transmits the time Code "7B:1"	The control unit receives the time Set code "81:3"	The control unit receives the time Set code "81:3"	Device receives the time
Control unit transmits outside temperature Set code "97:2"	Control unit receives outside temperature Set code "97:1"	Control unit receives outside temperature Set code "97:1"	--
LON participant fault monitoring Code "9C:20"	LON participant fault monitoring Code "9C:20"	LON participant fault monitoring Code "9C:20"	--

*1 Refer to the separate Installation Instructions of accessories.

General

Calling up coding level 1

Note: Codes are displayed as plain text.

Codes that have no function due to the heating system equipment level or the setting of other codes are not displayed.

Heating systems with one heating circuit without mixing valve and one or two heating circuits with mixing valve:

The heating circuit without a mixing valve is designated "Heating circuit 1" and the heating circuits with mixing valve as "Heating circuit 2" or "Heating circuit 3".

If the heating circuits were given individual designations, the selected designation and "HC1", "HC2" or "HC3" appear instead:

1. Press **OK** and  simultaneously for approximately 4 seconds.

2. "Coding level 1"
3. Select group of required coding address:
 - "General"
 - "Boiler"
 - "DHW"
 - "Solar"
 - "Heating circuit 1/2/3"
 - "All codes std device"

In this group, all coding addresses from coding level 1 (except the coding addresses from the "Solar" group) are displayed in ascending order.

4. Select coding address.
5. Select value according to the following tables and confirm with **OK**.
6. If you want to reset all codes to their factory setting: Select "Standard setting" in "Coding level 1".

Note: This also resets codes from coding level 2.

Select "General"

Coding			
Coding in the factory setting		Possible change	
System design			
00:1	System type 1: One heating circuit without mixing valve A1 (heating circuit 1), without DHW heating	00:2 to 00:10	For system type, see the following table:
Value address	System type	Description	
00: ...			
2	1	One heating circuit without mixing valve A1 (heating circuit 1), with DHW heating (code is adjusted automatically).	
3	2	One heating circuit with mixing valve M2 (heating circuit 2), without DHW heating.	
4	2	One heating circuit with mixing valve (heating circuit 2), with DHW heating.	
5	3	One heating circuit without mixing valve A1 (heating circuit 1) and one heating circuit with mixing valve M2 (heating circuit 2), without DHW heating (code is adjusted automatically).	
6	3	One heating circuit without mixing valve A1 (heating circuit 1) and one heating circuit with mixing valve M2 (heating circuit 2), with DHW heating (code is adjusted automatically).	
7	4	One heating circuit with mixing valve M2 (heating circuit 2) and one heating circuit with mixing valve M3 (heating circuit 3), without DHW heating.	
8	4	One heating circuit with mixing valve M2 (heating circuit 2) and one heating circuit with mixing valve M3 (heating circuit 3), with DHW heating.	
9	5	One heating circuit without mixing valve A1 (heating circuit 1), one heating circuit with mixing valve M2 (heating circuit 2) and one heating circuit with mixing valve M3 (heating circuit 3), without DHW heating (code is adjusted automatically).	
10	5	One heating circuit without mixing valve A1 (heating circuit 1), one heating circuit with mixing valve M2 (heating circuit 2) and one heating circuit with mixing valve M3 (heating circuit 3), with DHW heating (code is adjusted automatically).	

General *(continued)*

Coding in the factory set mode		Possible change	
Internal circulation pump function			
51:0	System with low loss header: Internal circulation pump always starts when there is a heat demand	51:1	System with low loss header: When there is a heat demand, the internal circulation pump is only started if the burner is operating. Circulation pump is switched off after a 60 sec. delay.
		51:2	System with heating water buffer DHW tank: When there is a heat demand, the internal circulation pump is only started if the burner is operating. Circulation pump is switched off after a 60 sec. delay.
Participant no.			
77:1	LON participant number	77:2 to 77:99	LON participant number, adjustable from 1 to 98: 1 - 8 = Boiler 9 = Cascade 10 - 98 = Vitotronic 200-H Note: Allocate each number only once.
Detached house/apartment building			
7F:1	Detached house	7F:0	Apartment building Separate adjustment of holiday program and time program for DHW heating possible.
Lock out controls			
8F:0	Operation in the standard menu and extended menu enabled. Note: The respective code is only activated when you exit the service menu.	8F:1	Operation in standard menu and extended menu blocked. Emissions test mode can be enabled.
		8F:2	Operation enabled in the standard menu and blocked in the extended menu. Emissions test mode can be enabled.
Set flow temperature for external demand			
9B:70	Set flow temperature for external demand 158°F (70°C)	9B:0 to 9B:127	Set flow temperature for external demand adjustable from 32 to 260°F (0 to 127°C) (limited by boiler-specific parameters).

Boiler

Select "Boiler"

Coding in the factory setting		Possible change	
Single/multi boiler system			
01:1	Single boiler system	01:2	Multi boiler system with Vitotronic 300-K, control.
Boiler number			
07:1	Boiler number in multi boiler systems	07:2 to 07:8	Boiler number 2 to 8 in multi-boiler systems.
Burner service in 100 hours			
21:0	No service interval (hours run) selected	21:1 to 21:100	Number of hours run before the burner should be serviced is adjustable from 100 to 10,000 h One adjusting step $\bar{\Delta}$ 100 h.
Service interval in months			
23:0	No time interval for burner service	23:1 to 23:24	Interval adjustable from 1 to 24 months.
Service status			
24:0	No "Service" display	24:1	"Service" display (the address is automatically set and must be manually reset after a service has been carried out).
Filling/Venting			
2F:0	Venting (bleeding) program/fill program disabled	2F:1	Venting (bleeding) program enabled.
		2F:2	Fill program enabled.

DHW

Select "DHW"

Coding in the factory setting		Possible change	
Set DHW temperature reheating suppression			
67:40	For solar DHW heating: Set DHW temperature 104°F (40°C). Reheating is suppressed above the selected set temperature (boiler is only connected as backup if the rise in DHW tank temperature is too low). Cannot be adjusted on gas condensing combi-boilers.	67:0 to 67:95	Set DHW temperature adjustable from 32 to 203°F (0 to 95°C) (limited by boiler-specific parameters).
Enable DHW recirculation pump			
73:0	DHW recirculation pump: "ON" in accordance with the time program	73:1 to 73:6	"ON" from once per hour for 5 minutes up to 6 times per hour for 5 minutes during the time program.
		73:7	Constantly "ON"

Solar

Select "Solar"

Note: The solar group is only displayed if a solar control module, type SM1, is connected.

Coding

Coding in the factory setting		Possible change	
Speed control solar circuit pump			
02:0	Solar circuit pump is not speed-controlled.	02:1	Solar circuit pump is speed-controlled with wave packet control.
		02:2	Solar circuit pump is speed-controlled with PWM control.
DHW tank maximum temperature			
08:60	The solar circuit pump is switched off when the actual DHW tank temperature reaches 140 °F (60 °C) (maximum DHW tank temperature).	08:10 to 08:90	Set DHW temperature adjustable from 50 to 194 °F (10 to 90 °C).
Stagnation time reduction			
0A:5	To protect the system components and heat transfer medium, the speed of the solar circuit pump is reduced when the differential between the actual DHW tank temperature and the set DHW tank temperature is less than 5 K.	0A:0	Stagnation time reduction disabled.
		0A:1 to 0A:40	Temperature differential adjustable from 1 to 40 K.
Flow rate solar circuit			
0F:70	Solar circuit flow rate at the maximum pump speed 7 L/minute.	0F:1 to 0F:255	Flow rate adjustable from 0.1 to 25.5 L/minute; 1 step $\bar{\Delta}$ 0.1 L/minute.
Extended solar control functions			
20:0	No extended control function enabled.	20:1	Additional function for DHW heating.
		20:2	Differential temperature control 2.
		20:3	Differential temperature control 2 and auxiliary function.
		20:4	Differential temperature control 2 for central heating backup.
		20:5	Thermostat function.
		20:6	Thermostat function and auxiliary function.
		20:7	Solar heating via external heat exchanger without additional temperature sensor.
		20:8	Solar heating via external heat exchanger with additional temperature sensor.
		20:9	Solar heating of two DHW tanks.

Heating Circuit 1, 2 and 3

Select "Heating circuit ..."

Coding

Coding in the factory setting		Possible change	
Priority DHW heating			
A2:2	DHW tank priority applicable to heating circuit pump and mixing valve	A2:0	Without DHW tank priority applied to heating circuit pump and mixing valve.
		A2:1	DHW tank priority only applicable to mixing valve.
		A2:3 to A2:15	Reduced priority applied to mixing valve (the heating circuit receives a reduced amount of energy).
Economy function outside temperature			
A5:5	With heating circuit pump logic function (economy mode): Heating circuit pump "OFF" when the outside temperature (AT) is 1 K higher than the set room temperature (RTset) AT > RTset + 1 K	A5:0	Without heating circuit pump logic function.
		A5:1 to A5:15	With heating circuit pump logic function: Heating circuit pump "OFF"; see following table.

Parameter address A5:...	With heating circuit pump logic function: Heating circuit pump "OFF"
1	AT > RTset + 5 K
2	AT > RTset + 4 K
3	AT > RTset + 3 K
4	AT > RTset + 2 K
5	AT > RTset + 1 K
6	AT > RTset
7	AT > RTset - 1 K
to 15	AT > RTset - 9 K

Coding in the factory setting		Possible change	
Extended economy function adjusted outside temperature			
A6:36	Extended economy function disabled	A6:5 to A6:35	Extended economy function enabled, i.e. the burner and heating circuit pump will stop and the mixing valve close at a variable value, adjustable between 41 and 95 °F (5 and 35 °C) plus 1.8 °F (1 °C). The base value is the adjusted outside temperature. This value is based on the actual outside temperature and a time constant, which takes the cooling down of an average building into consideration.

Heating Circuit 1, 2 and 3 (continued)

Coding in the factory setting		Possible change	
Extended economy function mixing valve			
A7:0	Without mixing valve economy function	A7:1	With mixing valve economy function (extended heating circuit pump logic): Heating circuit pump also "OFF": - If the mixing valve has been attempting to close for longer than 20 minutes. Heating circuit pump "ON": - If the mixing valve changes to control function. - If there is a risk of frost.
Pump idle time, transition reduced mode			
A9:7	With pump idle time: Heating circuit pump "OFF" if the set value is altered through a change in operating mode or through a change in the set room temperature	A9:0	Without pump idle time
		A9:1 to A9:15	With pump idle time, adjustable from 1 to 15.
Economy function room temperature			
B5:0	With remote control: No room temperature dependent heating circuit pump logic function	B5:1 to B5:8	Heating circuit pump logic function, see the following table:

Parameter address	With heating circuit pump logic function:	
	Heating circuit pump "OFF"	Heating circuit pump "ON"
B5:...		
1	$RT_{actual} > RT_{set} + 5\text{ K}$	$RT_{actual} < RT_{set} + 4\text{ K}$
2	$RT_{actual} > RT_{set} + 4\text{ K}$	$RT_{actual} < RT_{set} + 3\text{ K}$
3	$RT_{actual} > RT_{set} + 3\text{ K}$	$RT_{actual} < RT_{set} + 2\text{ K}$
4	$RT_{actual} > RT_{set} + 2\text{ K}$	$RT_{actual} < RT_{set} + 1\text{ K}$
5	$RT_{actual} > RT_{set} + 1\text{ K}$	$RT_{actual} < RT_{set}$
6	$RT_{actual} > RT_{set}$	$RT_{actual} < RT_{set} - 1\text{ K}$
7	$RT_{actual} > RT_{set} - 1\text{ K}$	$RT_{actual} < RT_{set} - 2\text{ K}$
8	$RT_{actual} > RT_{set} - 2\text{ K}$	$RT_{actual} < RT_{set} - 3\text{ K}$

Heating Circuit 1, 2 and 3 *(continued)*

Coding in the factory setting		Possible change	
Minimum flow temperature heating circuit			
C5:20	Electronic minimum flow temp. limit 68°F (20°C)	C5:1 to C5:127	Minimum limit adjustable from 34 to 260°F (1 to 127°C) (limited by boiler-specific parameters).
Maximum flow temperature heating circuit			
C6:74	Electronic maximum flow temperature limit 165°F (74°C)	C6:10 to C6:127	Maximum limit adjustable from 50 to 260°F (10 to 127°C) (limited by boiler-specific parameters).
Heating program - changeover			
D5:0	The external heating program changeover changes the heating program to "Constant operation with reduced room temperature" or "Standby mode"	D5:1	The external heating program changeover changes to "Constant operation with standard room temperature" (subject to coding address 3A, 3B and 3C).
Ext. heating program changeover to heating circuit			
D8:0	No heating program changeover via extension EA1	D8:1	Heating program changeover via input DE1 at extension EA1.
		D8:2	Heating program changeover via input DE2 at extension EA1.
		D8:3	Heating program changeover via input DE3 at extension EA1.
Maximum pump speed in standard mode			
E6:... NOT USED	Maximum speed of the variable speed heating circuit pump in % of the maximum speed in standard mode. Value is specified by boiler-specific parameters	E6:0 to E6:100	Maximum speed adjustable from 0 to 100%.
Minimum pump speed			
E7:50 NOT USED	Minimum speed of the variable speed heating circuit pump: 30% of the maximum speed	E7:0 to E7:100	Minimum speed adjustable from 0 to 100% of the maximum speed.
Slab curing function			
F1:0 NOT USED	Do not adjust	--	--
Party mode time limit			
F2:8	Time limit for party mode or external heating program changeover via push button: 8 h*1	F2:0	No time limit for party mode*1.
		F2:1 to F2:12	Time limit adjustable from 1 to 12 h*1.

*1 Party mode ends automatically in the "Heating and DHW" program, when the system changes over to operation with standard room temperature.

Heating Circuit 1, 2 and 3 *(continued)*

Coding in the factory setting		Possible change	
Pump control in "Only DHW"			
F6:25	In the "Only DHW" operating mode, the circulation pump in the heating circuit connection set is permanently ON	F6:0	In the "Only DHW" operating mode, the circulation pump in the heating circuit connection set is permanently OFF.
		F6:1 to F6:24	In the "Only DHW" operating mode, the circulation pump in the heating circuit connection set will be started 1 to 24 times per day for 10 minutes each time.
Pump control in "Standby mode"			
F7:25	In the "Standby" operating mode, the circulation pump in the heating circuit connection set is permanently ON	F7:0	In the "Standby" operating mode, the circulation pump in the heating circuit connection set is permanently OFF.
		F7:1 to F7:24	In the "Standby" operating mode, the circulation pump in the heating circuit connection set will be started 1 to 24 times per day for 10 minutes each time.
Start temperature raising			
F8:-5	Temperature limit for terminating the reduced mode 23°F (-5°C); see example on page 86. Observe the setting of coding address "A3"	F8: +10 to F8:-60	Temperature limit adjustable from +50 to -76°F (+10 to -60°C).
		F8:-61	Function disabled.
End temperature raising			
F9:-14	Temperature limit for raising the reduced set room temperature 6.8°F (-14°C); see example on page 94.	F9: +10 to F9:-60	Temperature limit for raising the set room temperature to the value selected for standard mode adjustable from 50 to -76°F (10 to -60°C).
Set flow temperature heating circuit			
FA:20	Raising the set boiler water temperature or the set flow temperature when changing from operation with reduced room temperature to operation with standard room temperature, by 20%. See example on page 94.	FA:0 to FA:50	Temperature rise adjustable from 0 to 50%.
Duration set flow temperature increase			
FB:30	Duration for raising the set boiler water temperature or the set flow temperature (see coding address "FA") 60 minutes. See example on page 94.	FB:0 to FB:150	Duration adjustable from 0 to 300 minutes; 1 step ~ 2 minutes.

General

Calling up coding level 2



Note: At coding level 2, all codes are accessible, including the codes at coding level 1.

Codes that have not been assigned due to the heating system equipment level or the setting of other codes are not displayed.

Heating systems with one heating circuit without mixing valve and one or two heating circuits with mixing valve:

The heating circuit without mixing valve is designated "Heating circuit 1" and the heating circuits with mixing valve as "Heating circuit 2" or "Heating circuit 3".

If the heating circuits were given individual designations, the selected designation and "HC1", "HC2" or "HC3" appear instead:

1. Press **OK** and  simultaneously for approximately 4 seconds.
 2. Press **OK** and  simultaneously for approximately 4 seconds.
 3. "Coding level 2"
 4. Select group of required coding address:
 - "General"
 - "Boiler"
 - "DHW"
 - "Solar"
 - "Heating circuit 1/2/3"
 - "All cod. or solar"

In this group, all coding addresses (except the coding addresses from the "Solar" group) are displayed in ascending order.
 5. Select coding address.
 6. Select value according to the following tables and confirm with **"OK"**.
 7. If you want to reset all codes to their factory setting: Select "Standard setting" in "Coding level 2".
- Note:** This also resets codes at coding level 1.

Select "General"

Coding

Coding in the factory setting		Possible change	
00:1	System type 1: One heating circuit without mixing valve A1 (heating circuit 1), without DHW heating	00:2 to 00:10	For system type, see the following table:

Value address 00: ...	System type	Description
2	1	One heating circuit without mixing valve A1 (heating circuit 1), with DHW heating (code is adjusted automatically).
3	2	One heating circuit with mixing valve M2 (heating circuit 2), without DHW heating.
4	2	One heating circuit with mixing valve (heating circuit 2), with DHW heating.
5	3	One heating circuit without mixing valve A1 (heating circuit 1) and one heating circuit with mixing valve M2 (heating circuit 2), without DHW heating (code is adjusted automatically).
6	3	One heating circuit without mixing valve A1 (heating circuit 1) and one heating circuit with mixing valve M2 (heating circuit 2), with DHW heating (code is adjusted automatically).

General *(continued)*

Value address 00: ...	System type	Description
7	4	One heating circuit with mixing valve M2 (heating circuit 2) and one heating circuit with mixing valve M3 (heating circuit 3), without DHW heating.
8	4	One heating circuit with mixing valve M2 (heating circuit 2) and one heating circuit with mixing valve M3 (heating circuit 3), with DHW heating.
9	5	One heating circuit without mixing valve A1 (heating circuit 1), one heating circuit with mixing valve M2 (heating circuit 2) and one heating circuit with mixing valve M3 (heating circuit 3), without DHW heating (code is adjusted automatically).
10	5	One heating circuit without mixing valve A1 (heating circuit 1), one heating circuit with mixing valve M2 (heating circuit 2) and one heating circuit with mixing valve M3 (heating circuit 3), with DHW heating (code is adjusted automatically).

Coding in the factory setting		Possible change	
11:≠9	No access to the coding addresses for the combustion controller parameters	11:9	Access open to the coding addresses for the combustion controller parameters.
20:74	Supply temperature for zone circuit 1 164°F (74°C)	20:20 to 20:85	Supply temperature for zone circuits adjustable from 68 to 185°F (20 to 85°C) (limited by boiler specific parameters).
27:74	Supply temperature for zone circuit 2 164°F (74°C)	27:20 to 27:85	Supply temperature for zone circuits adjustable from 68 to 185°F (20 to 85°C) (limited by boiler specific parameters).
2A:0	Without wireless outside temperature sensor	2A:1	With wireless outside temperature sensor (automatic recognition).
		2A:2	Wireless outside temperature sensor not used.
2C:74	Supply temperature for zone circuit 3 164°F (74°C)	2C:20 to 2C:85	Supply temperature for zone circuits adjustable from 68 to 185°F (20 to 85°C) (limited by boiler specific parameters).
2D:0	DO NOT ADJUST	--	--
32:0	Without extension AM1	32:1	With extension AM1 (automatic recognition).

General *(continued)*

Coding in the factory setting		Possible change	
33:1	Function output A1 at extension AM1: Heating circuit pump	33:0	Function output A1: DHW recirculation pump.
		33:2	Function output A1: Circulation pump for DHW tank heating.
		33:3	No function
		33:4	No function
		33:5	Zone circuit pump 1
		33:6	Zone circuit pump 2
		33:7	Zone circuit pump 3
34:0	Function output A2 at extension AM1: DHW recirculation pump	34:1	Function output A2: Heating circuit pump.
		34:2	Function output A2: Circulation pump for DHW tank heating.
		34:3	No function
		34:4	No function
		34:5	Zone circuit pump 1
		34:6	Zone circuit pump 2
		34:7	Zone circuit pump 3
35:0	Without extension EA1	35:1	With extension EA1 (automatic recognition).
36:0	Function, output 157 at extension EA1: Fault message	36:1	Function output 157 : Feed pump.
		36:2	Function output 157 : DHW recirculation pump.
		36:3-5	No function
		36:6	Zone circuit pump 1
		36:7	Zone circuit pump 2
		36:8	Zone circuit pump 3
39:2	Function output 21 : Circulation pump for DHW tank heating	39:0	Function output 21 : DHW recirculation pump.
		39:1	Function output 21 : Heating circuit pump.

General (continued)

Coding in the factory setting		Possible change	
3A:0	Function input DE1 at extension EA1: Not assigned	3A:1	Function input DE1: Heating program - changeover.
		3A:2	Function input DE1: External demand with set flow temperature. Flow temperature setting: Coding address 9B. Internal circulation pump function: Coding address 3F.
		3A:3	Function input DE1: External blocking. Internal circulation pump function: Coding address 3E.
		3A:4	Function input DE1: External blocking with fault message input Internal circulation pump function: Coding address 3E.
		3A:5	Function input DE1: Fault message input.
		3A:6	Function input DE1: Brief operation, DHW recirculation pump (pushbutton function). DHW recirculation pump runtime adjustment: Coding address 3D.
		3A:7	Input zone circuit 1, constant
		3A:8	Input zone circuit 1, weather compensated
3B:0	Function input DE2 at extension EA1: Not assigned	3B:1	Function input DE2: Heating program - changeover.
		3B:2	Function input DE2: External demand with set flow temperature. Flow temperature setting: Coding address 9B. Internal circulation pump function: Coding address 3F.
		3B:3	Function input DE2: External blocking. Internal circulation pump function: Coding address 3E.
		3B:4	Function input DE2: External blocking with fault message input Internal circulation pump function: Coding address 3E.
		3B:5	Function input DE2: Fault message input.
		3B:6	Function input DE2: Brief operation, DHW recirculation pump (pushbutton function). DHW recirculation pump runtime adjustment: Coding address 3D.
		3B:7	Input zone circuit 2, constant
		3B:8	Input zone circuit 2, weather compensated

General *(continued)*

Coding in the factory setting		Possible change	
3C:0	Function input DE3 at extension EA1: Not assigned	3C:1	Function input DE3: Heating program - changeover.
		3C:2	Function input DE3: External demand with set flow temperature. Flow temperature setting: Coding address 9B. Internal circulation pump function: Coding address 3F.
		3C:3	Function input DE3: External blocking. Internal circulation pump function: Coding address 3E.
		3C:4	Function input DE3: External blocking with fault message input Internal circulation pump function: Coding address 3E.
		3C:5	Function input DE3: Fault message input.
		3C:6	Function input DE3: Brief operation, DHW recirculation pump (pushbutton function). DHW recirculation pump runtime adjustment: Coding address 3D.
		3C:7	Input zone circuit 3, constant
		3C:8	Input zone circuit 3, weather compensated
3D:5	DHW recirculation pump runtime for brief operation: 5 minutes	3D:1 to 3D:60	DHW recirculation pump off-delay adjustable from 1 to 60 minutes.
3E:0	Internal circulation pump stays in control mode at signal "External blocking"	3E:1	Internal circulation pump stops at signal "External blocking".
		3E:2	Internal circulation pump starts at signal "External blocking".
3F:0	Internal circulation pump stays in control mode at signal "External demand"	3F:1	Internal circulation pump stops at signal "External demand".
		3F:2	Internal circulation pump starts at signal "External demand".
4B:0	Function input 96 : Room thermostat (Vitotrol 100) for constant temperature control	4B:1	External demand.
		4B:2	External blocking.

General (continued)

Coding in the factory setting		Possible change	
51:0	System with low loss header: Boiler circuit pump is always started when there is a heat demand	51:1	System with low loss header: When there is heat demand, the boiler circuit pump will only be started if the burner is running. Circulation pump is switched off when run-on time expires.
		51:2	System with heating water buffer DHW tank: When there is a heat demand, the internal circulation pump will only be started when the burner is operational.
52:0	Without flow temperature sensor for low loss header	52:1	With flow temperature sensor for low loss header (automatic recognition).
53:1	Function connection <input type="checkbox"/> of the internal extension: DHW recirculation pump	53:0	Function connection <input type="checkbox"/> : Central fault message
		53:2	Function connection <input type="checkbox"/> : External heating circuit pump (heating circuit 1).
		53:3	Function connection <input type="checkbox"/> : External circulation pump for DHW tank heating.
		53:4	No function
		53:5	Zone circuit pump 1
		53:6	Zone circuit pump 2
		53:7	Zone circuit pump 3
54:0	Without solar thermal system	54:1	With Vitosolic 100 (automatic recognition).
		54:2	With Vitosolic 200 (automatic recognition).
		54:3	With solar control module SM1 without auxiliary function (automatic recognition).
		54:4	With solar control module SM1 with auxiliary function, e.g. central heating backup (automatic recognition).
6E:50	No correction of measured outside temperature	6E:0 to 6E:100	Outside correction in 0.1 K steps 0 to 49 = -5 K to -0.1 K 51 to 100 = 0.1 K to 5 K
76:0	Without communication module	76:1	With LON communication module (recognized automatically).
		76:2	With cascade communication module (recognized automatically; only for constant temperature control units).

General (continued)

Coding in the factory setting		Possible change	
77:1	LON participant number	77:2 to 77:99	LON participant number, adjustable from 1 to 99: 1 - 8 = Boiler 9 = Cascade 10 - 98 = Vitotronic 200-H 99 = Vitocom Note: Allocate each number only once.
79:1	With LON communication module: Control unit is fault manager	79:0	Control unit is not fault manager.
7B:1	With LON communication module: Control unit transmits the time	7B:0	Does not transmit time.
7E:0 NOT USED	Without flue gas cascade or with flue gas cascade with negative pressure (only for multi boiler systems)	7E:1	With positive pressure flue gas cascade.
7F:1	Detached house	7F:0	Apartment building Separate adjustment of holiday program and time program for DHW heating possible.
80:6	A fault message is displayed if a fault is active for at least 30 seconds	80:0	Immediate fault message.
		80:2 to 80:199	Minimum fault duration until fault message occurs, adjustable from 10 s to 995 s; 1 step $\bar{\Delta}$ 5 seconds.
81:1 NOT USED	Automatic summer/wintertime changeover	81:0	Manual summer/wintertime changeover.
		81:2	Use of the radio clock receiver (automatic recognition).
		81:3	With LON communication module: The control unit receives the time.
82:0	Operation with natural gas	82:1	Operation with LPG (only adjustable if coding address 11:9 has been set).
86:0	DO NOT ADJUST	--	--
87:0	DO NOT ADJUST	--	--
88:0	Temperature display in °C (Celsius)	88:1	Temperature display in °F (Fahrenheit).

General (continued)

Coding in the factory setting		Possible change	
8A:175 DO NOT ADJUST	--	--	--
8F:0	Operation in the standard menu and extended menu enabled Note: The respective code is only activated when you exit the service menu	8F:1	Operation in the standard menu and extended menu blocked. Emissions test mode can be enabled
		8F:2	Operation enabled in the standard menu; blocked in the extended menu. Emissions test mode can be enabled
90:128	Time constant for calculating the adjusted outside temperature 21.3 h	90:1 to 90:199	Fast (low values) or slow (high values) matching of the flow temperature, subject to the set value when the outside temperature changes; 1 step $\bar{\Delta}$ 10 minutes.
93:0	0-5000 ft.	93:1 - 93:5	NOT USED
		93:6	5000-10000 ft.
94:0	Without Open Therm extension	94:1	With Open Therm extension (automatic recognition).
95:0	Without Vitocom 100 communication interface	95:1	With Vitocom 100 communication interface (automatic recognition).
97:0	With LON communication module: The outside temperature of the sensor connected to the control unit is utilized internally	97:1	Control unit receives outside temperature.
		97:2	Control unit transmits the outside temperature to the Vitotronic 200-H.
98:1	Viessmann system number (in conjunction with monitoring several systems via Vitocom 300)	98:1 to 98:5	System number adjustable from 1 to 5.
99:0	DO NOT ADJUST	--	--
9A:0	DO NOT ADJUST	--	--
9B:70	Set flow temperature for external demand 158°F (70°C)	9B:0 to 9B:127	Set flow temperature for external demand adjustable from 32 to 260°F (0 to 127°C) (limited by boiler-specific parameters).
9C:20	Monitoring LON participants. If a participant fails to respond, the values specified inside the control unit will be used after 20 minutes. Only then will a fault message be issued.	9C:0	No monitoring
		9C:5 to 9C:60	Time adjustable from 5 to 60 minutes.
9F:8	Differential temperature 8 K; only in conjunction with mixing valve circuit	9F:0 to 9F:40	Differential temperature adjustable from 0 to 40 K.

Boiler

Select "Boiler"

Coding

Coding in the factory setting		Possible change	
01:1	Single boiler system	01:2	Multi boiler system with Vitotronic 300-K.
04:1	Minimum burner pause subject to the boiler load (specified by boiler coding card)	04:0	Minimum burner pause set permanently (specified by boiler coding card).
06:...	Maximum limit of the boiler water temperature, specified in °C by the boiler coding card	06:20 to 06:127	Maximum limit of the boiler water temperature within the ranges specified by the boiler.
07:1	Boiler number in multi boiler systems	07:2 to 07:8	Boiler number 2 to 8 in multi- boiler systems.
08:...	Maximum burner heating output in kW in the case of a multi boiler system	08:0 to 08:199	Maximum burner heating output adjustable from 0 to 199 kW (limited by boiler specific parameters) in steps of 1 kW.
0D:0	DO NOT ADJUST	--	--
0E:0	DO NOT ADJUST	--	--
13:1	DO NOT ADJUST	--	--
14:1	DO NOT ADJUST	--	--
15:1	DO NOT ADJUST	--	--
21:0	No service interval (hours run) selected	21:1 to 21:100	Number of hours run before the burner should be serviced is adjustable from 100 to 10,000 h One adjusting step $\bar{\Delta}$ 100 h.
23:0	No time interval for burner service	23:1 to 23:24	Interval adjustable from 1 to 24 months.
24:0	No "Service" display	24:1	"Service" display (the address is automatically set and must be manually reset after a service has been carried out).
28:0	No burner interval ignition	28:1 to 28:24	Interval adjustable from 1 hour to 24 hours. The burner is force started for 15 seconds (only when operating with LPG).
2E:0	DO NOT ADJUST	--	--
2F:0	Venting program/fill program disabled	2F:1	Venting program enabled.
		2F:2	Fill program enabled.
30:0	Boiler circulation pump without variable speed (for use with single boiler systems with Low Loss Header, or multi-boiler systems)	30:1	Boiler variable speed circulation pump (automatic adjustment). DO NOT ADJUST
		30:2	Boiler variable speed circulation pump with flow control. DO NOT ADJUST
		30:3	Boiler variable speed circulation pump controlled via 0-10VDC output [147] When changing from a single boiler to a multiboiler operation, the coding address may automatically reset to 30:3. To prevent continuous boiler pump operation, adjust the coding address for each boiler to 30:0.
31:...	Set speed in % of the internal circulation pump when operated as boiler circuit pump, specified by the boiler coding card	31:0 to 31:100	Set speed adjustable from 0 to 100%.
38:0	Status burner control unit: Operational (no fault)	38:≠0	Status burner control unit: Fault.

DHW

Select "DHW"

Coding

Coding in the factory setting		Possible change	
56:0	Set DHW temperature adjustable from 50 to 140°F (10 to 60°C)	56:1	Set DHW temperature adjustable from 50 to over 140°F (10 to over 60°C) Note: Maximum value subject to boiler coding card. Observe the maximum permissible DHW temperature.
58:0	Without auxiliary function for DHW heating	58:10 to 58:60	Input of a second set DHW temperature, adjustable from 50 to 140°F (10 to 60°C) (observe coding addresses "56" and "63").
59:0	DHW tank heating: Starting point -2.5 K Stopping point +2.5 K	59:1 to 59:10	Starting point adjustable from 1 to 10 K below the set value.
5b:0	DHW tank directly connected to the boiler	5B:1	DHW tank connected downstream of the low loss header.
5E:0	Circulation pump for DHW tank heating stays in control mode at signal "External blocking"	5E:1	Circulation pump for DHW tank heating stops at signal "External blocking".
		5E:2	Circulation pump for DHW tank heating starts at signal "External blocking".
5F:0	Circulation pump for DHW tank heating stays in control mode at signal "External demand"	5F:1	Circulation pump for DHW tank heating stops at signal "External demand".
		5F:2	Circulation pump for DHW tank heating starts at signal "External demand".
60:20	During DHW heating, the boiler water temperature is maximum 20 K higher than the set DHW temperature	60:5 to 60:25	The differential between the boiler water temperature and the set DHW temperature is adjustable from 5 to 25 K.
62:2	Circulation pump with 2 minutes run-on time after DHW tank heating	62:0	Circulation pump without run-on.
		62:1 to 62:15	Run-on time adjustable from 1 to 15 minutes.

DHW (continued)

Coding in the factory setting		Possible change	
63:0 NOT USED	Without auxiliary function for DHW heating	63:1	Auxiliary function: 1 x daily
		63:2 to 63:14	Every 2 days to every 14 days.
		63:15	2 x daily
65:0	Do not adjust.	--	--
67:40	For solar DHW heating: Set DHW temperature 104°F (40°C). Reheating is suppressed above the selected set temperature (boiler is only connected as backup if the rise in DHW tank temperature is too low).	67:0 to 67:95	Set DHW temperature adjustable from 32 to 203°F (0 to 95°C) (limited by boiler-specific parameters).
6C:100 NOT USED	Set speed, internal circulation pump with DHW heating 100%	6C:0 to 6C:100	Set speed adjustable from 0 to 100%.
6F:...	Maximum output for DHW heating in %, specified by the boiler coding card	6F:0 to 6F:100	Maximum output for DHW heating adjustable from minimum output to 100%.
71:0	DHW recirculation pump: "ON" in accordance with the time program	71:1	"OFF" during DHW heating to first set value.
		71:2	"ON" during DHW heating to first set value.
72:0	DHW recirculation pump: "ON" in accordance with the time program	72:1	"OFF" during DHW heating to second set value.
		72:2	"ON" during DHW heating to second set value.
73:0	DHW recirculation pump: "ON" in accordance with the time program	73:1 to 73:6	"ON" from once per hour for 5 minutes up to 6 times per hour for 5 minutes during the time program.
		73:7	Constantly "ON".

Solar

Select "Solar"

Note: The solar group is only displayed if a solar control module, type SM1, is connected.

Coding

Coding in the factory setting		Possible change	
00:8	The solar circuit pump starts when the collector temperature exceeds the actual DHW tank temperature by 8 K.	00:2 to 00:30	The differential between the actual DHW tank temperature and the start point for the solar circuit pump can be adjusted from 2 to 30 K.
01:4	The solar circuit pump is switched off when the differential between the collector temperature and the actual DHW tank temperature is less than 4 K.	01:1 to 01:29	The differential between the actual DHW tank temperature and the stop point for the solar circuit pump can be adjusted from 1 to 29 K.
02:0	Solar circuit pump (stepped) is not speed-controlled	02:1	Solar circuit pump is speed-controlled with wave packet control.
		02:2	Solar circuit pump is speed-controlled with PWM control.
03:10	The temperature differential between the collector temperature and actual DHW tank temperature is regulated to 10 K.	03:5 to 03:20	The differential temperature control between collector temperature and actual DHW tank temperature can be adjusted from 5 to 20 K.
04:4	Controller amplification of the speed control 4%/K.	04:1 to 04:10	Controller amplification adjustable from 1 to 10%/K.
05:10	Minimum speed of the solar circuit pump 10% of the maximum speed.	05:2 to 05:100	Minimum speed of the solar circuit pump is adjustable from 2 to 100%.
06:75	Maximum speed of the solar circuit pump 75% of the maximum possible speed.	06:1 to 06:100	Maximum speed of the solar circuit pump is adjustable from 1 to 100%.
07:0	Interval function of the solar circuit pump switched off.	07:1	Interval function of the solar circuit pump switched on. To capture the collector temperature more accurately, the solar circuit pump starts for short cycles.
08:60	The solar circuit pump is switched off when the actual DHW tank temperature reaches 140°F (60°C) (maximum DHW tank temperature).	08:10 to 08:90	The maximum DHW tank temperature can be adjusted from 50 to 194°F (10 to 90°C).

Solar (continued)

Coding in the factory setting		Possible change	
09:130	The solar circuit pump stops if the collector temperature reaches 266°F (130°C) (maximum collector temperature to protect the system components)	09:20 to 09:200	Temperature adjustable from 68 to 392°F (20 to 200°C).
0A:5	Temperature differential for stagnation time reduction (reduction in the speed of the solar circuit pump to protect system components and heat transfer medium) 5 K.	0A:0 to 0A:40	The differential between the set DHW tank temperature and the start point for reducing the stagnation time can be adjusted from 0 to 40 K.
0B:0	Collector frost protection function switched off	0B:1	Collector frost protection function switched on (not required with Viessmann heat transfer medium).
0C:1	Δt monitoring switched on. No flow rate captured in the solar circuit, or flow rate too low.	0C:0	Δt monitoring switched off.
0D:1	Night circulation monitoring switched on. Unintentional flow rate is captured in the solar circuit (e.g. at night).	0D:0	Night circulation monitoring switched off.
0E:1	Calculation of solar yield with Viessmann heat transfer medium	0E:2	Calculation of solar yield with water as heat transfer medium (do not select as operation is only possible with Viessmann heat transfer medium).
		0E:0	Calculation of solar yield switched off.
0F:70	The flow rate in the collector circuit at the maximum pump speed is set to 1.8 USG (7 L/minute).	0F:1 to 0F:255	Flow rate in the collector circuit adjustable from 1.6 to 6.7 USG/minute (0.1 to 25.5 L/minute).
10:0	Target temperature control switched off (see coding address "11").	10:1	Target temperature control switched on.

Solar *(continued)*

Coding in the factory setting		Possible change	
11:50	<p>Set DHW tank temperature for solar 122°F (50°C).</p> <ul style="list-style-type: none"> - Target temperature control switched on (code 10:1): Temperature at which the solar heated water in the DHW tank is to be stratified. - Extended control functions set to heat two DHW tanks (code 20:9): If the actual temperature of a DHW tank reaches the selected set DHW tank temperature, heating is switched to the second DHW tank. 	11:10 to 11:90	The set DHW tank temperature for solar can be adjusted from 50 to 194°F (10 to 90°C).
12:20	<p>Minimum collector temperature 68°F (20°C).</p> <p>The solar circuit pump is only started when the set minimum collector temperature is exceeded at the collector temperature sensor.</p>	12:0	Minimum collector temperature function switched off.
		12:1 to 12:90	Minimum collector temperature adjustable from 34 to 194°F (1 to 90°C).
20:0	No extended control functions enabled.	20:1	Auxiliary function for DHW heating.
		20:2	Differential temperature control 2.
		20:3	Differential temperature control 2 and auxiliary function.
		20:4	Differential temperature control 2 for central heating backup.
		20:5	Thermostat function.
		20:6	Thermostat function and auxiliary function.
		20:7	Solar heating via external heat exchanger without additional temperature sensor.
		20:8	Solar heating via external heat exchanger with additional temperature sensor.
22:8	Start temperature differential for central heating backup: 8 K. (code 20:4 must be selected)	22:2 to 22:30	Start temperature differential for central heating backup is adjustable from 21 to 30 K.

Solar *(continued)*

Coding in the factory setting		Possible change	
23:4	Stop temperature differential for central heating backup: 4 K. (code 20:4 must be selected)	23:2 to 23:30	Stop temperature differential for central heating backup is adjustable from 1 to 29 K.
24:40	Start temperature for thermostat function 104°F (40°C). (code 20:5 or 20:6 must be selected)	24:0 to 24:100	Start temperature for thermostat function adjustable from 0 to 100 K.
25:50	Stop temperature for thermostat function 122°F (50°C). (code 20:5 or 20:6 must be selected)	25:0 to 25:100	Start temperature for thermostat function is adjustable from 0 to 100 K.
26:1	Priority for DHW tank 1 with alternate heating. Only when setting code 20:8.	26:0	Priority for DHW tank 1 without alternate heating.
		26:2	Priority for DHW tank 2 without alternate heating.
		26:3	Priority for DHW tank 2 with alternate heating.
		26:4	Alternate heating without priority for one of the DHW tank.
27:15	Alternate heating time 15 minutes. The DHW tank without priority is heated at most for the duration of the set alternate heating time if the DHW tank with priority is heated up.	27:5 to 27:60	The alternate heating time is adjustable from 5 to 60 minutes.
28:3	Alternate pause time 3 minutes After the selected alternate heating time for the DHW tank without priority has expired, the rise in collector temperature is captured during the alternate pause time.	28:1 to 28:60	The alternate pause time is adjustable from 1 to 60 minutes.

Heating Circuit 1, 2 and 3

Select "Heating circuit ..."

Coding

Coding in the factory setting		Possible change	
A0:0	Without remote control	A0:1	With Vitotrol 200A (automatic recognition).
		A0:2	With Vitotrol 300A or Vitohome 300 (automatic recognition).
A1:0	All possible settings at the remote control can be accessed	A1:1	Only party mode can be set at the remote control (only for Vitotrol 200A).
A2:2	DHW tank priority applicable to heating circuit pump and mixing valve	A2:0	Without DHW tank priority applied to heating circuit pump and mixing valve.
		A2:1	DHW tank priority only applicable to mixing valve.
		A2:3 to A2:15	Reduced priority applied to mixing valve (the heating circuit receives a reduced amount of energy).
A3:2	Outside temperature below 34°F (1°C): Heating circuit pump "ON" Outside temperature above 37°F (3°C): Heating circuit pump "OFF"	A3:-9 to A3:15	Heating circuit pump "ON/OFF" (see following table).

Note: When selecting a value below 1°C, there is a risk of pipes outside the thermal envelope of the building freezing up. The standby mode in particular should be taken into consideration, e.g. during holidays.

Parameter address A3:...	Heating circuit pump	
	"ON"	"OFF"
-9	14°F (-10°C)	17.6°F (-8°C)
-8	15.8°F (-9°C)	19.4°F (-7°C)
-7	17.6°F (-8°C)	21.2°F (-6°C)
-6	19.4°F (-7°C)	23°F (-5°C)
-5	21.2°F (-6°C)	24.8°F (-4°C)
-4	23°F (-5°C)	26.6°F (-3°C)
-3	24.8°F (-4°C)	28.4°F (-2°C)
-2	26.6°F (-3°C)	32.2°F (-1°C)
-1	28.4°F (-2°C)	32°F (0°C)
0	32.2°F (-1°C)	33.8°F (1°C)
1	32°F (0°C)	35.6°F (2°C)
2 to 15	33.8 to 57.2°F (1 to 14°C)	37.4 to 60.8°F (3 to 16°C)

Heating Circuit 1, 2 and 3 *(continued)*

Coding in the factory setting		Possible change	
A4:0	With frost protection	A4:1	No frost protection; this setting is only possible if code "A3:9" has been selected. Note: "Important" also coding address "A3".
A5:5	With heating circuit pump logic function (economy mode): Heating circuit pump "OFF" when the outside temperature (AT) is 1 K higher than the set room temperature (RTset) $AT > RTset + 1 K$	A5:0	Without heating circuit pump logic function.
		A5:1 to A5:15	With heating circuit pump logic function: Heating circuit pump "OFF"; see following table:

Parameter address A5:...	With heating circuit pump logic function: Heating circuit pump "OFF"
1	$AT > RTset + 5 K$
2	$AT > RTset + 4 K$
3	$AT > RTset + 3 K$
4	$AT > RTset + 2 K$
5	$AT > RTset + 1 K$
6	$AT > RTset$
7	$AT > RTset - 1 K$
to 15	$AT > RTset - 9 K$

Coding in the factory setting		Possible change	
A6:36	Extended economy function disabled	A6:5 to A6:35	Extended economy function enabled, i.e. the burner and heating circuit pump will stop and the mixing valve close at a variable value, adjustable between 41 and 95°F (5 and 35°C) plus 1.8°F (1°C). The base value is the adjusted outside temperature. This value is based on the actual outside temperature and a time constant, which takes the cooling down of an average building into consideration.
A7:0	Without mixing valve economy function	A7:1	With mixing valve economy function (extended heating circuit pump logic): Heating circuit pump also "OFF": - If the mixing valve has been attempting to close for longer than 20 minutes. - Heating circuit pump "ON": If the mixing valve changes to control function. - If there is a risk of frost.

Heating Circuit 1, 2 and 3 *(continued)*

Coding in the factory setting		Possible change	
A8:1	Heating circuit with mixing valve creates a demand for the boiler circuit pump	A8:0	Heating circuit with mixing valve creates no demand for the boiler circuit pump.
A9:7	With pump idle time: Heating circuit pump "OFF" if the set value is altered through a change in operating mode or through a change in the set room temperature	A9:0	Without pump idle time.
		A9:1 to A9:15	With pump idle time, adjustable from 1 to 15.
B0:0	With remote control: Heating mode/reduced mode: (only change the code for the heating circuit with mixing valve)	B0:1	Heating mode: weather compensated. Reduced mode: with room temperature hook-up.
		B0:2	Heating mode: with room temperature hook-up. Reduced mode: weather-compensated.
		B0:3	Heating mode/reduced mode: with room temperature hook-up.
B2:8	With remote control unit and for the heating circuit, operation with room temperature hook-up must be programmed: Room influence factor 8 (change the code only for the heating circuit with mixing valve)	B2:0	Without room influence.
		B2:1 to B2:64	Room influence factor adjustable from 1 to 64.
B5:0	With remote control: No room temperature-dependent heating circuit pump logic function (only change the code for the heating circuit with mixing valve)	B5:1 to B5:8	Heating circuit pump logic function, see the following table:

Parameter address b5:...	With heating circuit pump logic function:	
	Heating circuit pump "OFF"	Heating circuit pump "ON"
1	$RT_{actual} > RT_{set} + 5\text{ K}$	$RT_{actual} < RT_{set} + 4\text{ K}$
2	$RT_{actual} > RT_{set} + 4\text{ K}$	$RT_{actual} < RT_{set} + 3\text{ K}$
3	$RT_{actual} > RT_{set} + 3\text{ K}$	$RT_{actual} < RT_{set} + 2\text{ K}$
4	$RT_{actual} > RT_{set} + 2\text{ K}$	$RT_{actual} < RT_{set} + 1\text{ K}$
5	$RT_{actual} > RT_{set} + 1\text{ K}$	$RT_{actual} < RT_{set}$
6	$RT_{actual} > RT_{set}$	$RT_{actual} < RT_{set} - 1\text{ K}$
7	$RT_{actual} > RT_{set} - 1\text{ K}$	$RT_{actual} < RT_{set} - 2\text{ K}$
8	$RT_{actual} > RT_{set} - 2\text{ K}$	$RT_{actual} < RT_{set} - 3\text{ K}$

Heating Circuit 1, 2 and 3 *(continued)*

Coding in the factory setting		Possible change	
C5:20	Electronic minimum flow temperature limit 68°F (20°C)	C5:1 to C5:127	Minimum limit adjustable from 1 to 260°F (127°C) (limited by boiler-specific parameters).
C6:74	Electronic maximum flow temperature limit 165°F (74°C)	C6:10 to C6:127	Maximum limit adjustable from 50 to 260°F (10 to 127°C) (limited by boiler-specific parameters).
D3:14	Heating curve slope = 1.4	D3:2 to D3:35	Heating curve slope adjustable from 0.2 to 3.5 (see page 40).
D4:0	Heating curve level = 0	D4:-13 to D4:40	Heating curve level adjustable from -13 to 40 (see page 40).
D5:0	The external heating program changeover changes the heating program to "Constant operation with reduced room temperature" or "Standby mode"	D5:1	The external heating program changeover changes to "Constant operation with standard room temperature" (subject to coding address 3A, 3B and 3C).
D6:0	Heating circuit pump stays in control mode at signal "External blocking"	D6:1	Heating circuit pump stops at signal "External blocking" (subject to coding addresses 3A, 3B and 3C).
		D6:2	Heating circuit pump starts at signal "External blocking" (subject to coding addresses 3A, 3B and 3C).
D7:0	Heating circuit pump stays in control mode at signal "External demand"	D7:1	Heating circuit pump stops at signal "External demand" (subject to coding addresses 3A, 3B and 3C).
		D7:2	Heating circuit pump starts at signal "External demand" (subject to coding addresses 3A, 3B and 3C).
D8:0	No heating program changeover via extension EA1	D8:1	Heating program changeover via input DE1 at extension EA1.
		D8:2	Heating program changeover via input DE2 at extension EA1.
		D8:3	Heating program changeover via input DE3 at extension EA1.
E1:1	DO NOT ADJUST	--	--
E2:50	With remote control: No display correction for the actual room temperature	E2:0 to E2:49	Display correction -5 K to Display correction -0.1 K.
		E2:51 to E2:99	Display correction +0.1 K to Display correction +4.9 K.

Heating Circuit 1, 2 and 3 (continued)

Coding in the factory setting		Possible change	
E5:0	Do not adjust	--	--
E6:... NOT USED	Maximum speed of the variable speed heating circuit pump in % of the maximum speed in standard mode. Value is specified by boiler-specific parameters	E6:0 to E6:100	Maximum speed adjustable from 0 to 100%.
E7:50 NOT USED	Minimum speed of the variable speed heating circuit pump: 30% of the maximum speed	E7:0 to E7:100	Minimum speed adjustable from 0 to 100% of the maximum speed.
E8:1 NOT USED	Minimum speed in operation with reduced room temperature subject to the setting in coding address "E9"	E8:0	Speed subject to the setting in coding address "E7".
E9:45 NOT USED	Speed of the variable speed heating circuit pump: 45% of the maximum speed during operation with reduced room temperature	E9:0 to E9:100	Speed adjustable from 0 to 100% of the maximum speed during operation with reduced room temperature.
F1:0	Do not adjust	--	--
F2:8	Time limit for party mode or external heating program changeover via pushbutton: 8 h ^{*1}	F2:0	No time limit for party mode ^{*1} .
		F2:1 to F2:12	Time limit adjustable from 1 to 12 h ^{*1} .
F5:12	Run-on time of the boiler circuit pump in heating mode: 12 minutes.	F5:0	No run-on time for the circulation pump in the heating circuit connection set.
		F5:1 to F5:20	Run-on time of the circulation pump in the heating circuit connection set adjustable from 1 to 20 minutes.
F6:25	In the "Only DHW" operating mode, the circulation pump in the heating circuit connection set is permanently ON	F6:0	In the "Only DHW" operating mode, the circulation pump in the heating circuit connection set is permanently OFF.
		F6:1 to F6:24	In the "Only DHW" operating mode, the circulation pump in the heating circuit connection set will be started 1 to 24 times per day for 10 minutes each time.

^{*1} Party mode ends automatically in the "Heating and DHW" program, when the system changes over to operation with standard room temperature.

Heating Circuit 1, 2 and 3 *(continued)*

Coding in the factory setting		Possible change	
F7:25	In the "Standby" operating mode, the circulation pump in the heating circuit connection set is permanently ON	F7:0	In the "Standby" operating mode, the circulation pump in the heating circuit connection set is permanently OFF.
		F7:1 to F7:24	In the "Standby" operating mode, the circulation pump in the heating circuit connection set will be started 1 to 24 times per day for 10 minutes each time.
F8:-5	Temperature limit for terminating the reduced mode 23°F (-5°C); see example on page 86. Observe the setting of coding address "A3".	F8: +10 to F8:-60	Temperature limit adjustable from 50 to -76°F (10 to -60°C).
		F8:-61	Function disabled.
F9:-14	Temperature limit for raising the reduced set room temperature 6.8°F (-14°C); see example on page 94.	F9: +10 to F9:-60	Temperature limit for raising the set room temperature to the value selected for standard mode adjustable from 50 to -76°F (10 to -60°C).
FA:20	Raising the set boiler water temperature or the set flow temperature when changing from operation with reduced room temperature to operation with standard room temperature, by 20%. See example on page 86.	FA:0 to FA:50	Temperature rise adjustable from 0 to 50%.
FB:30	Duration for raising the set boiler water temperature or the set flow temperature (see coding address "FA") 60 minutes. See example on page 86.	FB:0 to FB:150	Duration adjustable from 0 to 300 minutes; 1 step $\bar{\Delta}$ 2 minutes).
1B:14	Heating curve slope = 1.4	1B:2 to 1B:35	Heating curve slope adjustable from 0.2 to 3.5. Zone circuit 1
1C:0	Heating curve level = 0	1C:-13 to 1C:40	Heating curve level adjustable from -13 to 40. Zone circuit 1
68:14	Heating curve slope = 1.4	68:2 to 68:35	Heating curve slope adjustable from 0.2 to 3.5. Zone circuit 2
69:0	Heating curve level = 0	69:-13 to 69:40	Heating curve level adjustable from -13 to 40. Zone circuit 2
6A:14	Heating curve slope = 1.4	6A:2 to 6A:35	Heating curve slope adjustable from 0.2 to 3.5. Zone circuit 3
6B:0	Heating curve level = 0	6B:-13 to 6B:40	Heating curve level adjustable from -13 to 40. Zone circuit 3

Calling up the Service Level

Press OK and  simultaneously for approximately 4 seconds.

Service menu overview

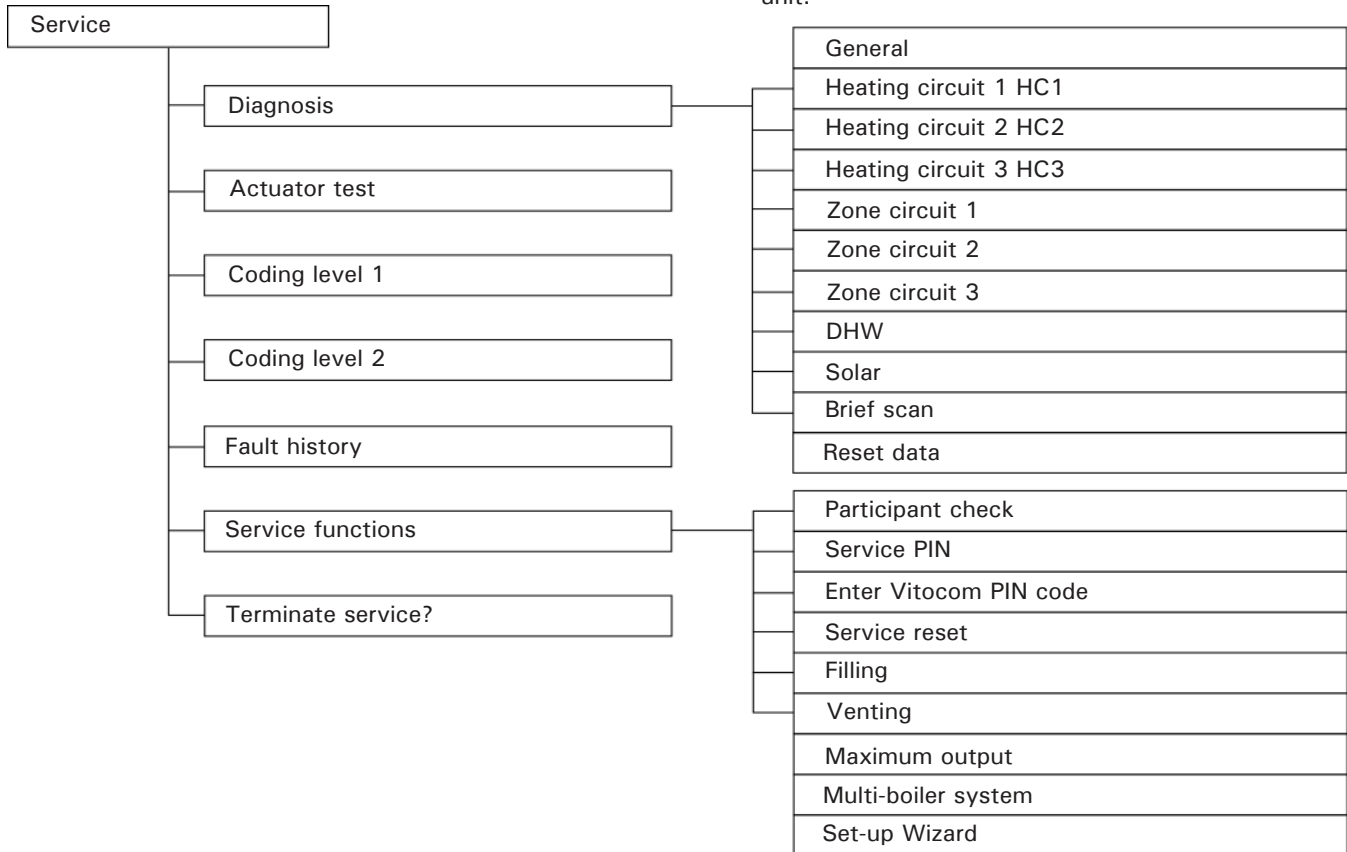

Note: Do not adjust menu item "Multi-boiler system". The menu item turns a weather-compensated control unit into a constant temperature control unit.

Exiting the service level

1. Select "Terminate service?".
2. Select "Yes".
3. Confirm with OK.

Note: The service level is automatically exited after 30 minutes.

Scanning operating data

- Operating data can be scanned in six areas. See "Diagnosis" in the service menu overview. Operating data on heating circuits with mixing valves and solar can only be scanned if the components are installed in the system. For further information on operating data, see chapter "Brief scan".

Note: "- - -" appears on the display if a sensor that has been scanned is faulty.



Refer to Operating instructions

Calling up operating data

1. Press OK and  simultaneously for approximately 4 seconds.
2. "Diagnosis"
3. Select required group, e.g. "General"

Resetting operating data

Saved operating data (e.g. hours run) can be reset to 0. The value "Adjusted outside temp" is reset to the actual value.

1. Press OK and  simultaneously for approximately 4 seconds.
2. "Diagnosis"
3. "Reset data"
4. Select required value (e.g. "Burner starts") or "All details".

Brief scan

In the brief scan, you can call up temperatures, software versions and connected components, for example.

1. Press OK and  simultaneously for approximately 4 seconds.
2. "Diagnosis"
3. "Brief scan".
4. Press OK. The display shows 9 lines with 6 fields each.

Diagnosis Brief scan					
1:	1	F	0	A	1 2
2:	0	0	0	0	0 0
3:	0	0	0	0	0 0
4:	0	0	0	0	0 0
Select with 					

Diagnosis

The following values can be scanned, depending on the system installed:

Display screen	Explanation
Slope A1*1 - shift A1 Slope M2*2 - shift M2 Outdoor temperature adjustment Outdoor temperature actual Boiler temperature setpoint Boiler temperature actual DHW temperature setpoint DHW temperature actual Supply temperature Supply temperature actual Common supply temperature setpoint Common supply temperature actual Boiler coding card Brief scan 1 to 8	The adjusted outdoor temperature can be reset to the actual outdoor temperature with "⌘". Heating circuit with mixing valve. Heating circuit with mixing valve. Low-loss header. Low-loss header.

For an explanation of the relevant values in the individual lines and fields, see the following table:

Line (brief scan)	Field					
	1	2	3	4	5	6
1:	System type 01 to 10		Software version control unit		Software version programming unit	
2:	0	0	Appliance version		Device identification ZE-ID	
3:	0		Number of KM BUS participants		Software version, solar control module SM1	
4:	Software version Burner control unit		Type Burner control unit		Burner control unit version	
5:	Internal details for calibration			0	Software version, extension AM1	Software version, extension EA1
6:	0	0	0	Flow rate sensor switching state 1: Flow rate too low or not present	0	0
7:	LON Subnet address/system number		LON Node address		0	
8:	LON SBVT configuration	LON software version communication co-processor	LON Neuron chip software version		Number of LON participants	

Diagnosis *(continued)*

For an explanation of the relevant values in the individual lines and fields, see the following table:

Line (brief scan)	Field					
	1	2	3	4	5	6
9:	Heating circuit A1 (without mixing valve)		Heating circuit M2 (with mixing valve)		Heating circuit M2 (with mixing valve)	
	Remote control 0: w/o 1: Vitotrol 200/200A/ 200 RF 2: Vitotrol 300/300A/ 300 RF or Vitohome	Software version remote control	Remote control 0: w/o 1: Vitotrol 200/200A/ 200 RF 2: Vitotrol 300/300A/ 300 RF or Vitohome	Software version remote control	Remote control 0: w/o 1: Vitotrol 200/200A/ 200 RF 2: Vitotrol 300/300A/ 300 RF or Vitohome	Software version remote control
10: (only for KM BUS circulation pumps)	Internal circulation pump		Heating circuit pump, heating circuit M2		Heating circuit pump, heating circuit M3	
	Variable speed pump 0: Without 1: Wilo 2: Grundfos	Software version, variable speed pump 0: No variable speed pump	Variable speed pump 0: Without 1: Wilo 2: Grundfos	Software version Variable speed pump 0: No variable speed pump	Variable speed pump 0: Without 1: Wilo 2: Grundfos	Software version Variable speed pump 0: No variable speed pump
11:	0	0	Software version Mixing valve extension heating circuit M2 0: No mixing valve extension	0	Software version Mixing valve extension heating circuit M3 0: No mixing valve extension	0

Checking Outputs (Relay Test)

1. Press OK and  simultaneously for approximately 4 seconds.
2. "Actuator test"

The following relay outputs can be controlled subject to system design:

Display		Explanation
All actuators	Off	All actuators are off.
Base load	On	Burner operated at minimum output; circulation pump is started.
Full load	On	Burner operated at maximum output; circulation pump is started.
Output, internal	On	Output 20 active (boiler circuit pump).
Output 21/28	On	Output 21 active (circulation pump for DHW tank heating).
Htg circ pump HC2	On	Heating circuit pump output enabled (extension to heating circuit with mixing valve).
Mixing valve HC2	Open	"Mixing valve open" output enabled (extension to heating circuit with mixing valve).
Mixing valve HC2	Close	"Mixing valve close" output enabled (extension to heating circuit with mixing valve).
Htg circ pump HC3	On	Heating circuit pump output enabled (extension to heating circuit with mixing valve).
Mixing valve HC3	Open	"Mixing valve open" output enabled (extension to heating circuit with mixing valve).
Mixing valve HC3	Close	"Mixing valve close" output enabled (extension to heating circuit with mixing valve).
Outp. int. exten. H1	On	Output at internal extension enabled.
AM1 output 1	On	Output A1 at extension AM1 enabled.
AM1 output 2	On	Output A2 at extension AM1 enabled.
EA1 output 1	On	Contact P - S at plug 157 of extension EA1 closed.
Solar circuit pump	On	Solar circuit pump output 24 on solar control module SM1 active.
Solar circuit pump minimum	On	Solar circuit pump output on solar control module SM1 switched to minimum speed.
Solar circuit pump maximum	On	Solar circuit pump output on solar control module SM1 switched to maximum speed.
SM1 output 22	On	Output 22 on solar control module SM1 active.

Fault Display

In the event of a fault, red fault indicator A flashes. "A" flashes on the display and "Fault" is shown.

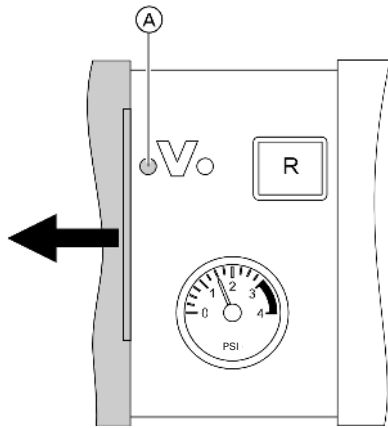

The fault code is displayed with OK. For an explanation of the fault code, see the following pages. For some faults, the type of fault is also displayed in plain text.

Acknowledging a fault

Follow the instructions on the display.

Note: The fault message is transferred to the standard menu. A fault message facility, if connected, will be switched OFF. If an acknowledged fault is not remedied, the fault message will be re-displayed the following day and the fault message facility restarted.

Calling up acknowledged faults

Select "Fault" in the standard menu.

The current faults will be displayed in a list.

Calling up fault codes from the fault memory (fault history)

The 10 most recent faults (including resolved ones) are saved and can be called up.

Faults are sorted by date.

1. Press OK and simultaneously for approximately 4 seconds.
2. "Fault history"
3. "Display?"

Fault Codes

Fault code on display	Detailed fault code *2	System behavior *1	Cause	Corrective action
0F	-	Control mode	Code "0F" is only displayed in the fault history	Service required Note: After servicing select code "24:0"
10	-	Boiler operates based on outdoor temperature of 32°F (0°C)	Short circuit on outdoor temperature sensor	Check the outdoor temperature sensor (see page 85).
18	-	Boiler operates based on outdoor temperature of 32°F (0°C)	Outdoor temperature sensor cable broken	Check the outdoor temperature sensor (see page 85).
1A	-	Burner blocked	Flow sensor 1 faulty	Replace sensor (see page 86)
1B	-	Burner blocked	Flow sensor 2 faulty	Replace sensor (see page 86)
1F	-	Burner blocked	Differential flow rate too large	Clean heat exchanger by flushing
20	-	Regulates without supply temperature sensor (low-loss header)	Short circuit on system flow temperature sensor	Check the low-loss header sensor (see page 86).
28	-	Regulates without supply temperature sensor (low-loss header)	System supply temperature sensor cable broken	Check the low-loss header sensor (see page 86). If no low loss header sensor is connected, set code 52:0.

*1 Control mode: Boiler/burner fully operational (fault code must be verified and reset).
 Burner in fault mode: Boiler control requires manual reset before burner can resume operation.
 Burner blocked: If fault cause is corrected, burner resumes operation.

*2 Detailed fault code coding address 38:xx (if available).

Fault Codes *(continued)*

Fault code on display	Detailed fault code *2	System behavior *1	Cause	Corrective action
30	140	Burner blocked	Short circuit on boiler water temperature sensor	Check the boiler water temperature sensor (see page 86).
38	140	Burner blocked	Boiler water temperature sensor cable broken	Check the boiler water temperature sensor (see page 86).
40	-	Mixing valve closes	Heating circuit 2 with mixing valve supply short circuit on temperature sensor	Check the supply temperature sensor [2] (see page 86).
44	-	Mixing valve closes	Short circuit, flow temperature sensor, heating circuit 3 (with mixing valve)	Check flow temperature sensor (see page 86).
48	-	Mixing valve closes	Heating circuit 2 with mixing valve supply temperature sensor cable broken	Check the supply temperature sensor [2] (see page 86).
4C	-	Mixing valve closes	Flow temperature sensor cable broken circuit 3 (with mixing valve)	Check flow temperature sensor (see page 86).
50	-	No DHW heating	Short circuit on DHW tank temperature sensor [5]	Check the DHW sensor [5] (see page 86).
58	-	No DHW heating	Tank temperature sensor [5] cable broken	Check the DHW sensor [5] (see page 86).
90	-	Control mode	Short circuit on temperature sensor [7]	Check sensor [7] on solar control module.
91	-	Control mode	Short circuit on temperature sensor [10]	Check sensor [10] on solar control module.
92	-	No solar DHW heating	Short circuit on collector temperature sensor [6]	Check the sensor [6] at the solar control module.
93	-	Control mode	Short circuit on collector temperature sensor [6]	Check the sensor [6] at the solar control module.
94	-	No solar DHW heating	Short circuit on tank temperature sensor [5]	Check the sensor [5] at the solar control module.
98	-	Control mode	Tank temperature sensor [7] cable broken	Check sensor [7] on solar control module.
99	-	Control mode	Temperature sensor [10] cable broken	Check sensor [10] on solar control module.
9A	-	No solar DHW heating	Collector temperature sensor [6] cable broken	Check the sensor [6] at the solar control module.
9B DO NOT USE		Control mode	Tank temperature sensor cable broken	Check temperature sensor at connection S3 to the Vitosolic solar control.

*1 Control mode: Boiler/burner fully operational (fault code must be verified and reset).
 Burner in fault mode: Boiler control requires manual reset before burner can resume operation.
 Burner blocked: If fault cause is corrected, burner resumes operation.

*2 Detailed fault code coding address 38:xx (if available).

Fault Codes *(continued)*

Fault code on display	Detailed fault code *2	System behavior *1	Cause	Corrective action
9C	-	No solar DHW heating	Tank temperature sensor [5] cable broken	Check temperature sensor [5] on solar control module.
9E	-	Control mode	No flow rate in collector circuit or flow rate too low or temperature limiter has responded	Check solar circuit pump and solar circuit. Acknowledge fault message.
9F	-	Control mode	Solar control module faulty	Replace solar control module.
A3	-	Burner blocked	Flue gas temperature sensor not properly positioned	Properly install flue gas temperature sensor.
A4 DO NOT USE	-	Control mode	Max. system pressure exceeded	Check system pressure (max. system pressure 3 bar). Check the function and sizing of the diaphragm expansion vessel. Vent the heating system
A7	-	Control mode (stays in factory default setting)	Faulty programming unit	Replace the programming unit.
B0	141	Burner blocked	Flue gas temperature sensor shorted out	Check flue gas temperature sensor (see page 86).
B1	-	Control mode (stays in factory default setting)	Communication fault; programming unit (internal)	Check connections and replace programming unit if required.
B5	-	Control mode (factory default setting)	Internal fault	Replace the control unit.
B7	-	Burner blocked	Boiler coding card missing, faulty or incorrect boiler coding card	Plug in boiler coding card or replace if faulty.
B8	141	Burner blocked	Flue gas temperature sensor cable broken	Check flue gas temperature sensor (see page 86).
BA	-	Mixing valve regulates to a flow temperature of 68°F (20°C)	Communication fault - accessory kit for heating circuit 2 with mixing valve	Check extension kit connections and code.
BB	-	Mixing valve regulates to a flow temperature of 68°F (20°C)	Communication error, extension kit for heating circuit 3 (with mixing valve)	Check extension kit connections and code.
BC	-	Control mode without remote control	Communication error, remote control Vitotrol heating circuit 1 (without mixing valve)	Check connections, cable, coding address "A0" in "Heating circuit" group and remote control unit setting.

*1 Control mode: Boiler/burner fully operational (fault code must be verified and reset).
 Burner in fault mode: Boiler control requires manual reset before burner can resume operation.
 Burner blocked: If fault cause is corrected, burner resumes operation.

*2 Detailed fault code coding address 38:xx (if available).

Fault Codes *(continued)*

Fault code on display	Detailed fault code *2	System behavior *1	Cause	Corrective action
BD	-	Control mode without remote control	Communication error, remote control Vitotrol heating circuit 2 (with mixing valve)	Check connections, cable, coding address "A0" in "Heating circuit" group and remote control unit setting.
BE	-	Control mode with out remote control	Communication error, remote control Vitotrol heating circuit 3 (with mixing valve)	Check connections, cable, coding address "A0" in "Heating circuit" group and remote control unit setting.
BF	-	Control mode	Incorrect LON communication module	Replace LON communication module.
C1	-	Control mode	Communication fault extension EA1	Check connections.
C2	-	Control mode	Communication fault - solar control unit or Vitosolic	Check solar control or Vitosolic.
C3	-	Control mode	Extension AM1 communication fault	Check connections.
C4	-	Control mode	Communication fault, Open Therm extension	Check Open Therm extension.
C5	-	Control mode, max. pump speed	Communication error, variable speed internal pump	Check setting of coding address "30"
CD DO NOT USE	-	Control mode	Communication fault, Vitocom 100 (KM-BUS)	Check connections Vitocom 100 coding address "95"
CF	-	Control mode	Communication fault - LON communication module	Replace LON communication module.
D6	-	Control mode	Input DE1 reports a fault at extension EA1	Remove fault at appliance concerned.
D7	-	Control mode	Input DE2 reports a fault at extension EA1	Remove fault at appliance concerned.

*1 Control mode: Boiler/burner fully operational (fault code must be verified and reset).
 Burner in fault mode: Boiler control requires manual reset before burner can resume operation.
 Burner blocked: If fault cause is corrected, burner resumes operation.

*2 Detailed fault code coding address 38:xx (if available).

Fault Codes *(continued)*

Fault code on display	Detailed fault Code *2	System behavior *1	Cause	Corrective action
D8	-	Control mode	Input DE3 reports a fault at extension EA1	Remove fault at appliance concerned.
DA	-	Control mode without room influence	Short circuit on room temperature sensor, heating circuit 1 without mixing valve	Check the room temperature sensor, heating circuit 1 without mixing valve.
DB	-	Control mode without room influence	Room temperature sensor, shorted out heating circuit 2 with mixing valve	Check the room temperature sensor, heating circuit 2.
DC	-	Control mode without room influence	Short circuit, room temperature sensor, heating circuit 3 (with mixing valve)	Check room temperature sensor, heating circuit 3
DD	-	Control mode without room influence	Room temperature sensor cable broken, heating circuit 1 without mixing valve	Check the room temperature sensor, heating circuit 1 and the remote control setting (see page 86).
DE	-	Control mode without room influence	Room temperature sensor cable broken, heating circuit 2 with mixing valve	Check the room temperature sensor, heating circuit 2 and the remote control settings (see page 86).
DF	-	Control mode without room influence	Room temperature sensor cable broken, heating circuit 3 (with mixing valve)	Check room temperature sensor for heating circuit 3 and remote control settings (see page 86).
E0	-	Control mode	Fault external LON participant	Check connections and LON participants.
E1	202	Burner in a fault mode	Ionization current too high during calibration	Check gap between ionization electrode and burner gauze assembly (see page 26). In open flue mode, prevent very dusty conditions for the combustion air. Press reset button R .
E2 NOT USED	201	Burner in a fault mode	Heating water flow rate too low during calibration.	Ensure adequate circulation volume. Check boiler pump flow. Remove scaling, blockage. Press reset button R .
E3	204	Burner in a fault mode	Heat transfer too low during calibration. Temperature limiter caused shutdown.	Ensure adequate heat transfer. Press reset button R .

*1 Control mode: Boiler/burner fully operational (fault code must be verified and reset).
 Burner in fault mode: Boiler control requires manual reset before burner can resume operation.
 Burner blocked: If fault cause is corrected, burner resumes operation.

*2 Detailed fault code coding address 38:xx (if available).

Fault Codes *(continued)*

Fault code on display	Detailed fault code *2	System behavior *1	Cause	Corrective action
E4	-	Burner blocked	Fault, supply voltage 24V	Replace the control unit.
E5	226	Burner blocked	Fault flame amplifier	Replace control unit.
E7	192	Burner in a fault mode	Ionization current too low during calibration	Check ionization electrode: - Distance to burner gauze assembly (see page 26). - Contamination of electrode. - Connecting lead and plug-in connections. Check flue system; remedy flue gas recirculation if required. Press reset button R .
E8	189	Burner in a fault mode	The ionization current lies outside the permissible range	Check gas supply (gas pressure and gas flow limiter), gas valve and connecting lead. Check allocation of gas type (see page 19). Check ionization electrode: - Distance to burner gauze assembly (see page 26). - Contamination of electrode Press reset button R .
EA	193	Burner in a fault mode	The ionization current lies outside the permissible range during calibration (deviation from previous level too great)	Check flue system; remedy flue gas recirculation if required In open flue mode, prevent very dusty conditions for the combustion air. Press reset button R . Following several unsuccessful reset attempts, replace boiler coding card and press reset button R .
EB	194	Burner in a fault mode	Repeated flame loss during calibration	Check gap between ionization electrode and burner gauze assembly (see page 26). Check allocation of gas type (see page 19). Check flue system; remedy flue gas recirculation if required. Press reset button R .
EC	67 or 195	Burner in a fault mode	Parameter fault during calibration	Press reset button R or Replace boiler coding card and press reset button R .
ED	191	Burner in a fault mode	Internal fault	Replace control unit.

*1 Control mode: Boiler/burner fully operational (fault code must be verified and reset).
 Burner in fault mode: Boiler control requires manual reset before burner can resume operation.
 Burner blocked: If fault cause is corrected, burner resumes operation.

*2 Detailed fault code coding address 38:xx (if available).

Fault Codes (continued)

Fault code on display	Detailed fault code *2	System behavior *1	Cause	Corrective action
EE	132	Burner in a fault mode	At burner start, flame signal is missing or too weak	Check gas supply (gas pressure and gas regulator). Check gas train. Check ionization electrode and connecting cable. Check ignition: - Connecting leads to ignition module and ignition electrode. - Ignition electrode gap and contamination (see page 26). Check condensate drain. Press reset button R .
EF	138	Burner in a fault mode	Flame is lost immediately after it has built (during the safety time)	Check gas supply (gas pressure and gas regulator). Check flue gas/ventilation air system for flue gas recirculation. Check ionization electrode (replace if required): - Distance to burner gauze assembly (see page 26). - Contamination of electrode Press reset button R .
F0	-	Burner blocked	Internal fault	Replace the control unit.
F1	135	Burner in a fault mode	Maximum flue gas temperature exceeded 230°F (110°C) limit.	Check heating system fill level. Bleed air from system. Check circulation pump. Check boiler water temperature sensor and cable. Press reset button R after vent system has cooled down.
F2	129	Burner in fault mode	Fixed high limit switch open (activated)	Check heating system fill level. Check the circulation pump. Bleed air from the system. Check fixed high limit switch and connecting cables. Press reset button R .
F3	139	Burner in fault mode	Flame signal already present at burner start	Check the ionization electrode and connecting cable. Press reset button R .
F6	-	Burner in a fault state	Boiler water temperature sensor temperature values vary too widely from one another	Replace boiler water temperature sensors
F8	148	Burner in fault mode	Gas valve closes too late	Check the gas valve. Check both control wiring/connections. Press reset button R .
F9	151 or 152	Burner in fault mode	Fan speed too low during burner start	Check the fan, the fan cables and power supply. Check the fan control. Press reset button R .

*1 Control mode: Boiler/burner fully operational (fault code must be verified and reset).
 Burner in fault mode: Boiler control requires manual reset before burner can resume operation.
 Burner blocked: If fault cause is corrected, burner resumes operation.

*2 Detailed fault code coding address 38:xx (if available).

Fault Codes *(continued)*

Fault code on display	Detailed fault code *2	System behavior *1	Cause	Corrective action
F9	151 or 152	Burner in fault mode	Fan speed too low during burner start	Check the fan, the fan cables and power supply. Check the fan control. Press reset button R .
FA	154	Burner in fault mode	Fan not at standstill	Check the fan, the fan connecting cables and fan control. Check the fan control. Press reset button R .
FC	190	Burner in fault mode	Gas valve faulty or faulty modulation valve control; or vent system blocked	Check the gas valve. Check the vent system. Press reset button R .
FD	227	Burner in a fault state and additional fault B7 is displayed	Boiler coding card is missing	Insert the boiler coding card. Press reset button R . Replace control unit if fault persists.
	-	Burner in a fault state	Fault, burner control unit	Check ignition electrodes and connecting cables. Check whether a strong interference (EMC) field exists near the appliance. Press reset button R . Replace control unit if fault persists.
FE	158, 159, 162 or 225	Burner in fault mode	Damaged or incorrect boiler coding card or main PCB	Press reset button R . If the fault persists, check the boiler coding card or replace it or the control unit.
FF	224	Burner in fault mode	Internal fault or reset button R blocked	Restart the equipment. Replace the control unit if the equipment will not restart.
N/A	2	Burner in hold/wait state, boiler not displaying fault refer to coding address 38:XX	Gas supply - no/low gas pressure detected	Check gas supply pressure
	5		Flame failure during stabilization	Check ionization electrode
	6		Boiler temperature has exceeded the monitoring limit	Check boiler temperature sensor
	8		Flue gas temperature has exceeded the monitoring limit	Check flue gas temperature sensor
	29		Open circuit at terminals 1 and L on Multi terminal of the power pump	Check connection at terminals 1 and L (jumper or installed safety equipment of the Multi terminal of the power pump module).
	33		Power supply voltage, is below minimal operation level, internal fuse failure.	Check power, replace control

*1 Control mode: Boiler/burner fully operational (fault code must be verified and reset).
 Burner in fault mode: Boiler control requires manual reset before burner can resume operation.
 Burner blocked: If fault cause is corrected, burner resumes operation.

*2 Detailed fault code coding address 38:xx (if available).

Corrective Action

Continuous boiler pump operation

When the Vitodens 200 B2HA boiler is switched from a single boiler operation to a multi-boiler operation, coding addresses 30:0 may automatically reset to 30:3. This will result in the boiler pump operating continuously. Verify that the coding address for each boiler is 30:0. Adjust to 30:0 if necessary. Refer to page 60.

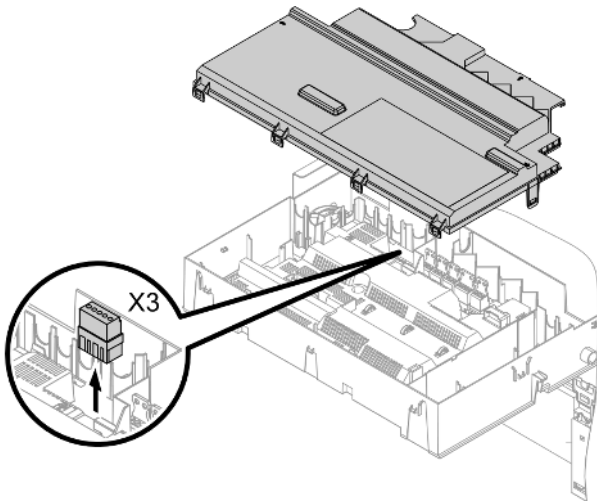

Checking the outside temperature sensor

1. Pull plug "X3" from the control unit.
2. Test the resistance of the outside temperature sensor across terminals "X3.1" and "X3.2" on the disconnected plug and compare it with the curve.
3. Where actual values deviate severely from the curve values, disconnect the wires at the sensor and repeat test on the sensor itself.
4. Depending on the result, replace the lead or the outside temperature sensor. Sensor type: NTC 10 kΩ

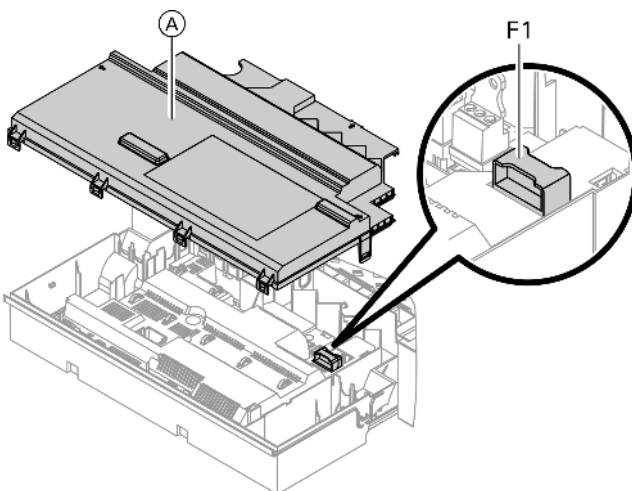
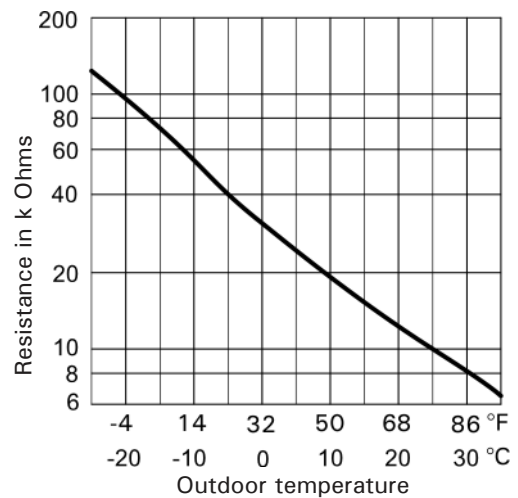

Check fuse

1. Switch OFF the power.
2. Release side latches and pivot the control unit down.
3. Remove cover (A).
4. Check fuse F1 (see wiring diagram on page 95).

Check fuses in the external accessories connection box

1. Switch OFF the power.
2. Open external accessories connection box and check fuses F1 and F2 (see wiring diagram on page 95).

Corrective Action *(continued)*

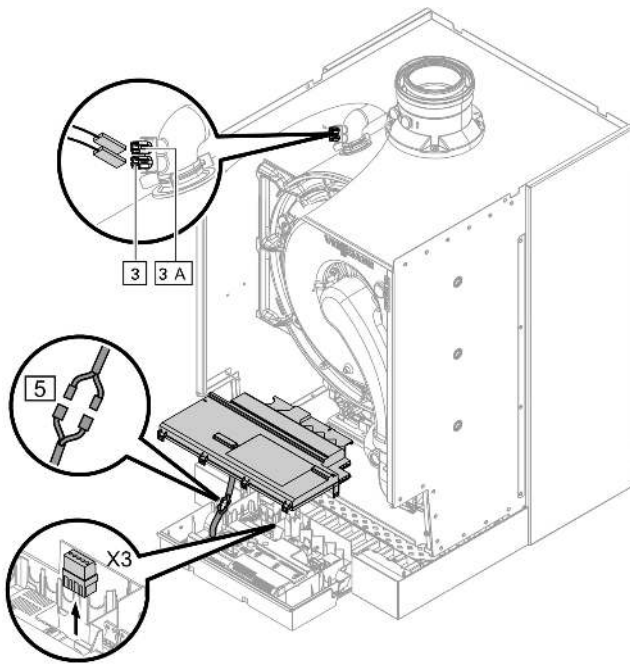

Checking the boiler temperature sensor and fixed high limit, DHW tank temperature sensor or flow temperature sensor for the low loss header

1. Boiler temperature sensor:
Remove lead to boiler water temperature sensor [3] or [3]A and check the resistance.
- DHW Tank temperature sensor:
Pull plug [5] from the cable harness at the control unit and check the resistance.
- Supply temperature sensor or Low-loss header temperature sensor [2]:
Pull plug "X3" from the control unit and check the resistance across terminals "X3.4" and "X3.5".
Note: Only one temperature sensor [2] may be used.
2. Check the sensor resistance and compare the actual values with the curve.
3. Replace the sensor in the case of severe deviation.
Sensor type: NTC 10 kΩ

WARNING

The boiler water temperature sensors are immersed in the heating water (risk of scalding). Drain the boiler before replacing the sensor.

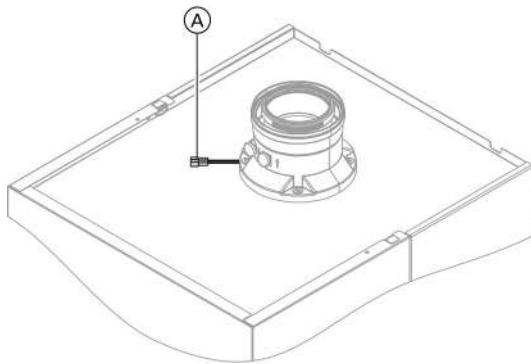

Check the flue gas temperature sensor

The flue gas temperature sensor locks out the boiler when the permissible flue gas temperature is exceeded. Reset the interlock after the flue system has cooled down by pressing reset button R.

1. Pull leads from flue gas temperature sensor (A).
2. Check the sensor resistance and compare it with the curve.
3. Replace the sensor in the case of severe deviation.
Sensor type: NTC 10 kΩ

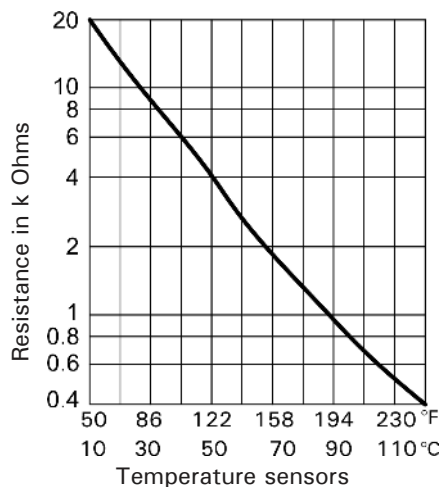

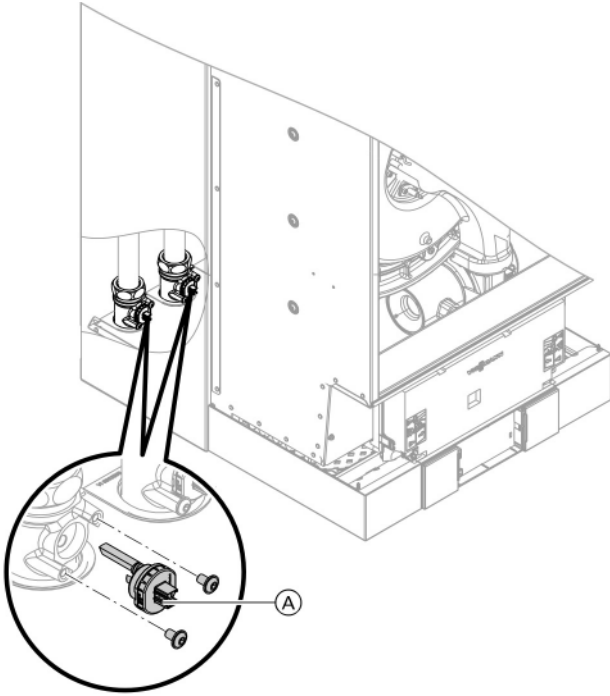

Corrective Action *(continued)***Replacing the flow rate sensor**

Note: In the event of a fault, both sensors need to be replaced.

1. Drain the boiler on the heating water side.
2. Pull leads from flow rate sensor (A).
3. Undo screws and remove faulty flow rate sensor (A).
4. Install new flow rate sensor (A) and secure with the screws.

Corrective Action *(continued)*

Heating circuit	Rotary selector S1 setting
Heating circuit with mixing valve M2 (heating circuit 2)	2 
Heating circuit with mixing valve M3 (heating circuit 3)	4 

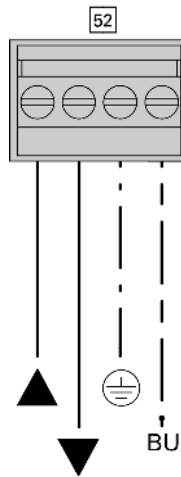

Extension kit for heating circuit with mixing valve

Checking the setting of rotary selector S1:

The rotary selector on the PCB of the extension kit defines the assignment to the relevant heating circuit.

Note: The rotational direction of the mixing valve motor during its self-test. Then set the mixing valve manually to “Open”.

Note: The flow temperature sensor must now capture a higher temperature. If the temperature drops, either the motor is turning in the wrong direction or the mixing valve set is incorrectly fitted.

Checking the rotational direction of the mixing valve motor

After being switched on, the boiler implements a self-test. During this, the mixing valve is opened and closed again.

Changing the rotational direction of the mixing valve motor (if required)

1. Remove the upper casing cover of the extension kit.

⚠ WARNING

 Electric shock hazard indicates an imminently hazardous situation which, if not avoided, may result in loss of life, serious injury or substantial product / property damage. Before opening the boiler, disconnect main power.

2. At plug 52, switch the cores at terminals “▲” and “▼”.
3. Refit the casing cover.

Checking the Vitotronic 200-H (accessories)

The Vitotronic 200-H is connected to the control unit via the LON. To test the connection, carry out a participant check at the boiler control unit (see page 43).

External Extensions AM1 (accessory)

Functions

One of the following circulation pumps can be connected to each of the connections A1 and A2:

- Heating circuit pump for the heating circuit without mixing valve, zone circuit pump
- Circulation pump for DHW tank heating
- DHW recirculation pump

Select the output functions by means of the codes on the boiler control unit.

Function assignment

Function	Code ("General" group)	
	Output A1	Output A2
DHW recirculation pump 28	33:0	34:0 (delivered condition)
Heating circuit pump 20	33:1 (delivered condition)	34:1
Circulation pump for DHW tank heating 21	33:2	34:2
Zone circuit pump 1	33:5	33:5
Zone circuit pump 2	33:6	33:6
Zone circuit pump 3	33:7	33:7

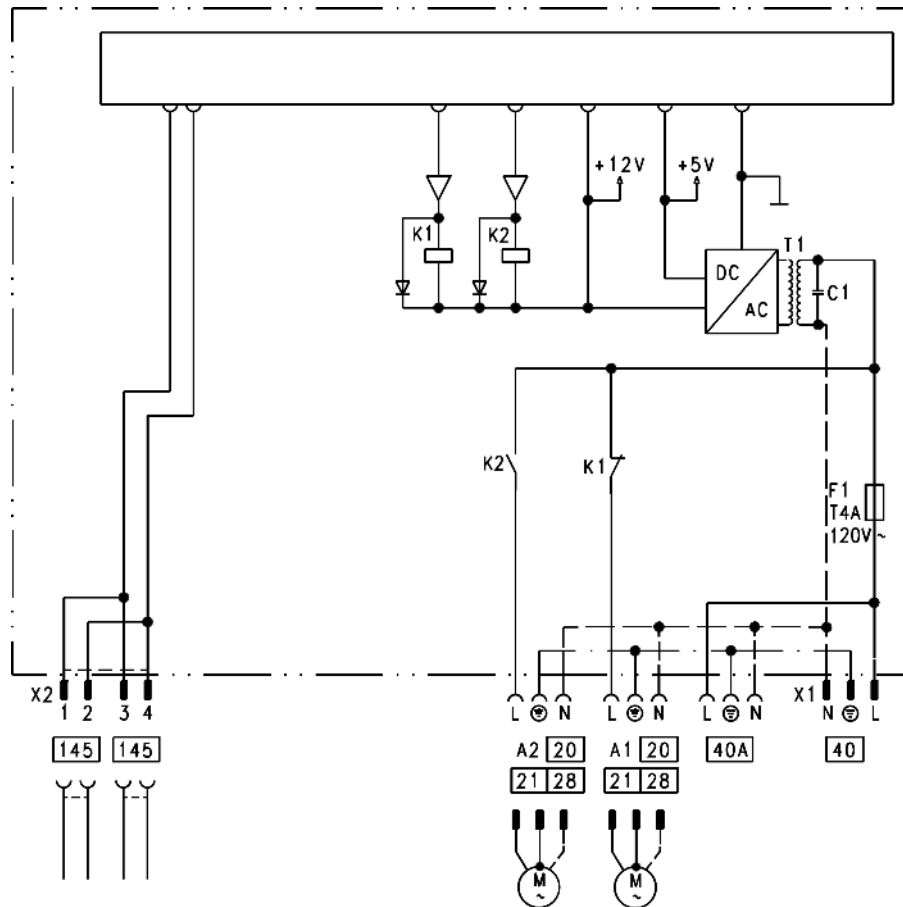

Legend

- A1 Circulation pump
- A2 Circulation pump
- 40 Power supply
- 40A A Power supply for additional accessories
- 145 KM BUS



Refer to the AM1 module Installation Instructions.

Internal Extensions EA1

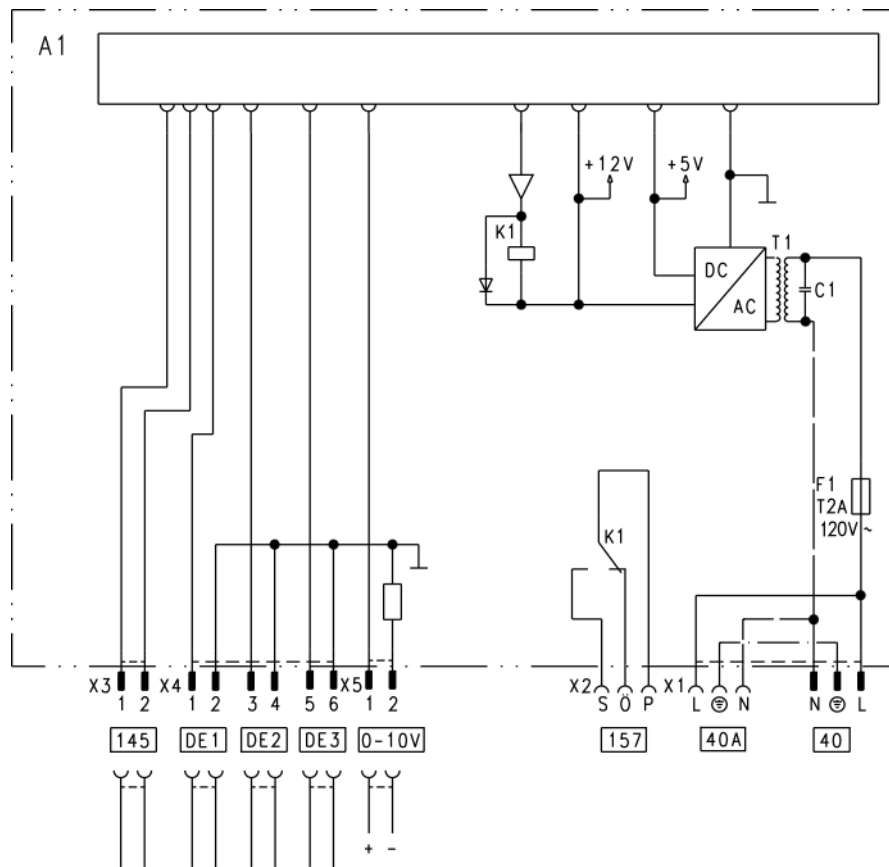

Legend

- A1 PCB
- F1 Fuse
- DE1 Digital input 1
- DE2 Digital input 2
- DE3 Digital input 3
- 0 – 10V 0 - 10V input
- 40 Power supply
- 40 Power supply for additional accessories
- 157 Central fault message/ feed pump/DHW recirculation pump (potential-free)
- 145 KM BUS

Refer to main wiring diagram on page 95.

Internal Extensions EA1 *(continued)*

Digital data inputs DE1 to DE3

The following functions can be connected alternatively:

- External heating program changeover for each heating circuit
- External blocking
- External blocking with fault message input
- External demand with minimum boiler water temperature
- Fault message input
- Brief operation of the DHW recirculation pump
- Operation of zone circuit pump

External contacts must be floating.
 When connecting external contacts, observe the requirements of safety category II, i.e. 8.0 mm air and creep path or 2.0 mm insulation thickness to 'live' parts.

Input function assignment

Select the input functions by means of codes in the "General" group at the boiler control unit:

- DE1: Coding address 3A
- DE2: Coding address 3B
- DE3: Coding address 3C

Assigning the heating program changeover function to the heating circuits

Select the heating program changeover function for the respective heating circuit via coding address D8 in the "Heating circuit" group at the boiler control unit:

- Changeover via input DE1: Code D8:1
- Changeover via input DE2: Code D8:2
- Changeover via input DE3: Code D8:3

The effect of the heating program changeover is selected via coding address D5 in the "Heating circuit" group.
 The duration of the changeover is set via coding address F2 in the "Heating circuit" group.

Effect of the external blocking function on the pumps

The effect on the internal circulation pump is selected in coding address 3E in the "General" group.
 The effect on the respective heating circuit pump is selected in coding address D6 in the "Heating circuit" group.
 The effect on a circulation pump for DHW tank heating is selected in coding address 5E in the "DHW" group.

Effect of the external demand function on the pumps

The effect on the internal circulation pump is selected in coding address 3F in the "General" group.
 The effect on the respective heating circuit pump is selected in coding address D7 in the "Heating circuit" group.
 The effect on a circulation pump for DHW tank heating is selected in coding address 5F in the "DHW" group.

DHW recirculation pump runtime for brief operation

The DHW recirculation pump is started by closing the contact at DE1, DE2 or DE3 by means of a pushbutton.
 The runtime is adjusted via coding address "3D" in the "General" group.

Analog input 0 - 10V

The 0 - 10V hook-up provides an additional set boiler water temperature:
 0 - 1V taken as "no default for set boiler water temperature"
 1V $\bar{\wedge}$ set value 10°C
 10V $\bar{\wedge}$ set value 100°C
 Ensure DC separation between the ground conductor and the negative pole of the on-site voltage source.

Output 157

The following functions can be connected to output 157:

- DHW recirculation pump
or
- Fault message facility
or
- Zone circuit pump

Function assignment

Select the function of output 157 via coding address "36" in the "General" group at the boiler control unit.

Assigning zone circuit

Zone Circuit	Coding
zone circuit 1 DE1	3A:7 Constant
	3A:8 Weather compensate
zone circuit 2 DE2	3B:7 Constant
	3B:8 Weather compensate
zone circuit 3 DE3	3C:7 Constant
	3C:8 Weather compensate

Control Functions

External heating program changeover

The “External heating program changeover” function is connected via input “EA1” in the EACB.

You can select which direction the heating program changeover takes in coding address “D5”:

The “External heating program changeover” function is connected via extension EA1. There are 3 inputs available at extension EA1 (DE1 to DE3).

The function is selected via the following codes:

Heating program changeover	Coding
Input DE1	3A:1
Input DE2	3B:1
Input DE3	3C:1

Assign the heating program changeover function for the respective heating circuit with code D8 at the boiler control unit:

Heating program changeover	Coding
Changeover via input DE1	D8:1
Changeover via input DE2	D8:2
Changeover via input DE3	D8:3

You can select which direction the heating program changeover takes in coding address “D5”.

Heating program changeover	Coding
Changeover towards “Permanently reduced” or “Permanent standby” mode (based on the selected setpoint)	D5:0
Changeover towards “Constant heating mode”	D5:1

The duration of the heating program changeover can be adjusted in coding address “F2”:

Heating program changeover	Coding
No changeover	F2:0
Duration of the heating program changeover 1 to 12 hours	F2:1 to F2:12

The heating program changeover stays enabled for as long as the contact remains closed, but at least as long as the duration selected in coding address “F2”.

External blocking

The “External blocking” and “External blocking and fault message input” functions are connected via extension EA1. There are 3 inputs available at extension EA1 (DE1 to DE3).

The function is selected via the following codes:

External blocking	Coding
Input DE1	3A:3
Input DE2	3B:3
Input DE3	3C:3
External blocking and fault message input	Coding
Input DE1	3A:4
Input DE2	3B:4
Input DE3	3C:4

The effect on the internal circulation pump is selected with code 3E. Select the effect on the respective heating circuit pump with code D6.

External demand

The “External demand” function is connected via extension EA1. There are 3 inputs available at extension EA1 (DE1 to DE3).

The function is selected via the following codes:

External demand	Coding
Input DE1	3A:2
Input DE2	3B:2
Input DE3	3C:2

The effect on the internal circulation pump is selected with code 3F. The effect on the respective heating circuit pump is selected with code D7.

The minimum set boiler water temperature in case of external demand is selected in coding address “9B”.

Control Functions *(continued)*

Venting program

During the venting program, the circulation pump will be alternately switched on and off for 30 seconds respectively over a period of 20 minutes. The burner is switched off during the venting program. Activate venting program: See "Venting the heating system".

Bleeding air program

During the bleeding air program, the circulation pump will be alternately switched on and off for 30 seconds respectively over a period of 20 minutes. The burner is switched off during the venting program. Activate venting program: See "Venting the heating system".

Fill program

If the system is to be filled with the control unit switched ON, code "2F:2" starts the pump. The burner shuts down if this function is enabled via coding address "2F". The program is automatically disabled after 20 minutes and coding address "2F" is reset to "0".

Reducing the heat-up time

During the transition from operation with reduced room temperature to operation with standard room temperature, the boiler water or supply temperature will be raised in accordance with the selected heating curve. The boiler water or supply temperature can be automatically increased. The value and duration of the additional increase of the set boiler water temperature or supply temperature can be adjusted in coding addresses "FA" and "FB".

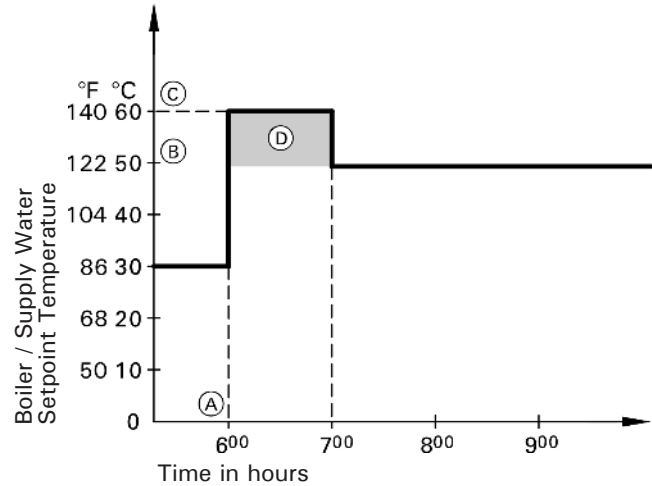

- (A) Start of operation with standard room temperature
- (B) Boiler water / supply temperature based on selected heating curve
- (C) Boiler water / supply temperature based on coding address "FA": $50^{\circ}\text{C} + 20\% = 60^{\circ}\text{C}$
- (D) Duration of operation with raised boiler water / supply temperature based on coding address "FB": 60 minutes

Control Functions *(continued)*

Raising the reduced room temperature

During operation with reduced room temperature, the reduced room setpoint temperature can be automatically raised based on the outdoor temperature.

The temperature is raised in accordance with the selected heating curve, but no higher than the standard room temperature setpoint. The outdoor temperature limits for the start and end of the temperature raising can be adjusted via coding addresses "F8" and "F9".

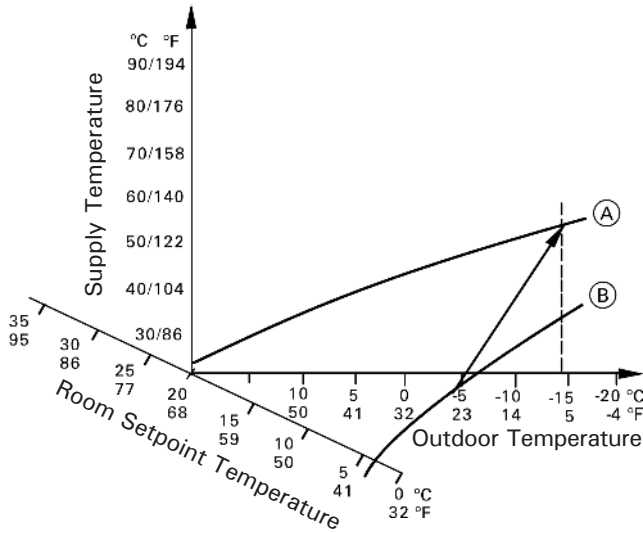

- (A) Heating curve for operation with standard room temperature
- (B) Heating curve for operation with reduced room temperature

Allocating heating circuits to the remote control

The heating circuit allocation must be configured when commissioning the Vitotrol 200A or Vitotrol 300A.

Heating circuit	Configuration	
	Vitotrol 200A	Vitotrol 300A
The remote control affects the heating circuit without mixing valve A1	H1	HC1
The remote control affects the heating circuit with mixing valve M2	H2	HC2
The remote control affects the heating circuit with mixing valve M3	H3	HC3

Note: One heating circuit can be allocated to the Vitotrol 200A. Up to three heating circuits can be allocated to the Vitotrol 300A. Up to 2 remote controls may be connected to the control unit. If the heating circuit allocation is later cancelled, reset coding address A0 for this heating circuit to 0 (fault message BC, BD, BE).

Wiring Diagram

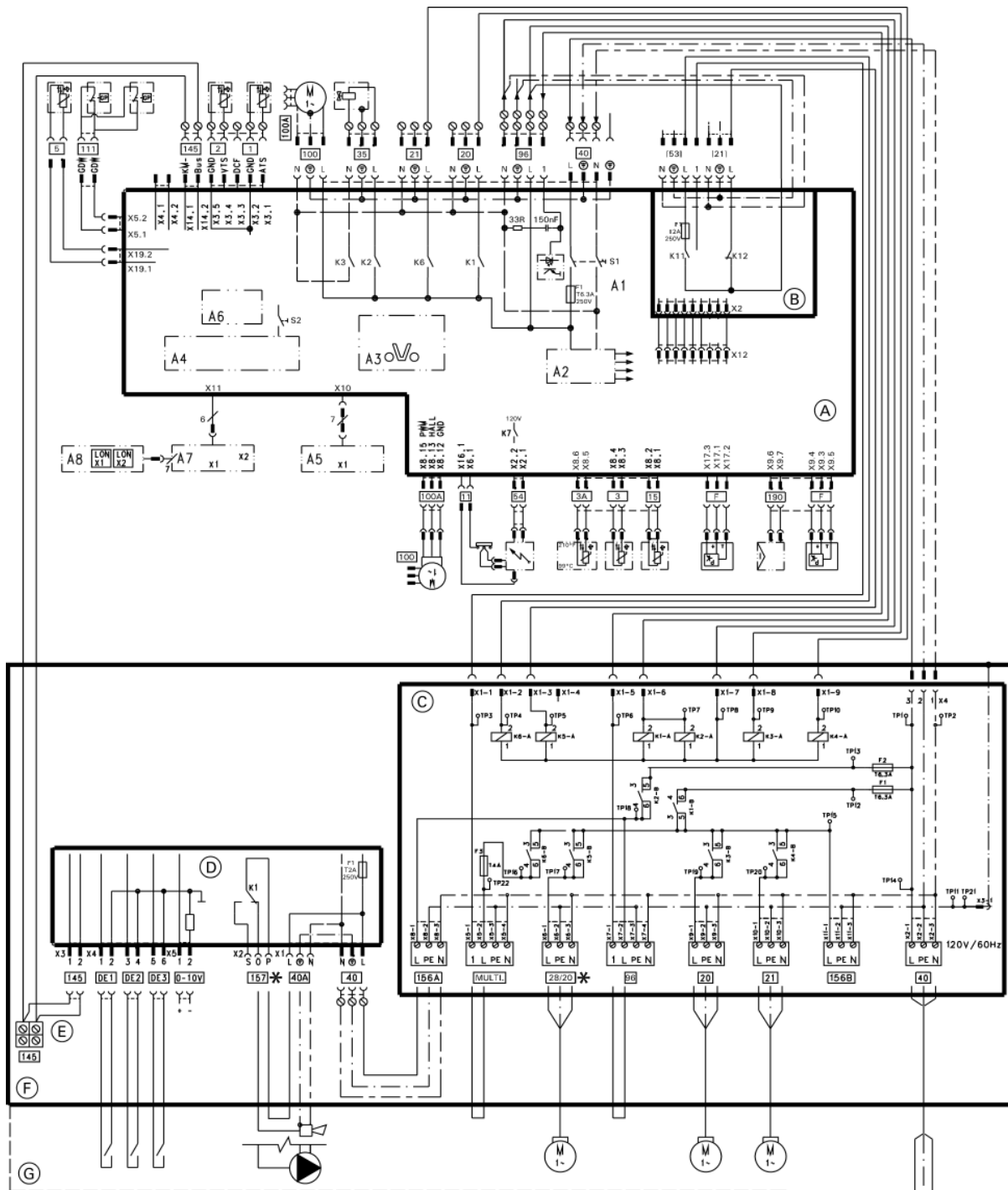

⚠ WARNING
DISCONNECT POWER BEFORE SERVICING BOILER.

If any of the original wires as supplied with the appliance must be replaced, it must be replaced with the exact equivalent.

⚠ CAUTION
 Label all wires prior to disconnection when servicing controls. Wiring errors can cause improper and dangerous operation. Verify proper operation after servicing.

* Only one function/accessory may be assigned to each connection.

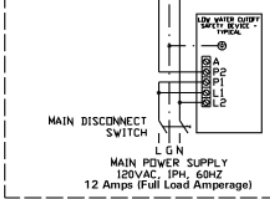

Wiring Diagram *(continued)***Legend**

1	Outdoor Temperature Sensor
2	Supply Temperature Sensor/Low Loss Header
3	Boiler Temperature Sensor/High Limit Sensor
3A	Boiler Temperature Sensor/High Limit Sensor
5	DHW Temperature Sensor
11	Ionization Electrode
15	Flue Gas temperature Sensor
20	Boiler Pump
21	DHW Pump
[21]	Pump Output Connection
28/20	Programmable Pump Output / zone circuit pump output*
35	Gas Valve
40	Power Supply
40A	Accessory Power Output
[53]	Powered Accessory Connection
54	Ignition Transformer
96	Powered Accessory Connection
100	Fan Motor
100A	Fan Motor Control
111	Low and High Pressure Gas Switches
145	KM BUS
Multi	Powered Accessory Connection
156A	Switched Output F2
156B	Switched Output F1
DE1	Digital Input 1 (Dry Contact)
DE2	Digital Input 2 (Dry Contact)
DE3	Digital Input 3 (Dry Contact)
0-10V	0-10VDC Input
157	Fault Alarm/DHW Recirc. Pump / zone circuit pump output*
190	Gas Modulation Coil
F	Flow Sensor

* See wiring diagram

- Ⓐ Boiler Control
- Ⓑ External Accessory Connection Board
- Ⓒ Pump Connection Interface
- Ⓓ Extension Module EA1
- Ⓔ KM-BUS for External Devices
- Ⓕ Electrical Junction Box
- Ⓖ Field Wiring Connections
- A1 Main Board
- A2 Internal Power Supply Unit
- A3 Optolink
- A4 Burner Control Unit
- A5 Programming Unit
- A6 Coding Card
- A7 Connection Adaptor
- A8 LON Communication Module
- S1 ON/OFF Switch
- S2 Reset Button
- X.. Electrical Interface

IMPORTANT

Electrical installations must comply with the latest edition of:

- In the U.S.A., the National Electrical Code (NEC), ANSI/NFPA 70 and any other state, local codes and/or regulations.
- In Canada, the Canadian Electrical Code (CEC), CSA C22.1 Part 1 and any other province, territory, local codes and/or regulations.

Burner Program Sequence of Operation

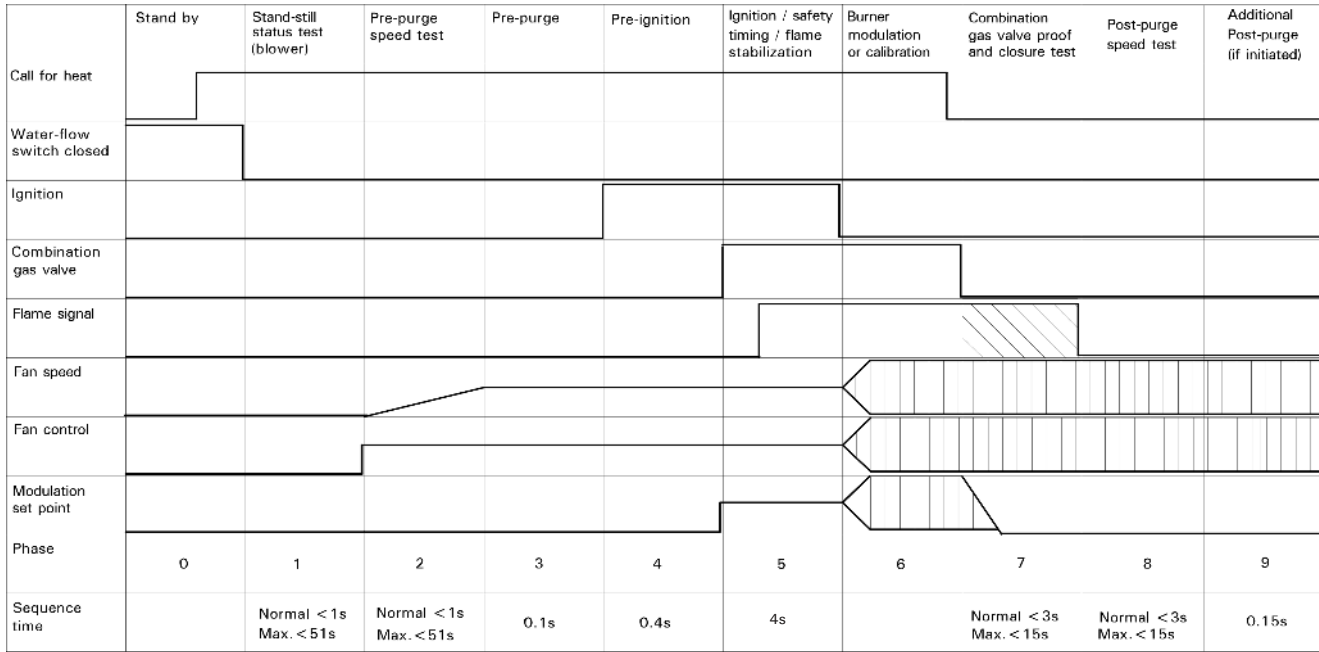

Modulation range Transition

Phase 0: Stand-by

Complete shutdown until the next call for heat. In this phase both the combination gas valve and the blower are not energized.

Phase 1: Stand-still status test (blower)

A call for heat initiates internal blower sensory communications to confirm that the blower is truly in stand-still position. Blower speed measured must be < 300 rpm within a 51 second period.

Phase 2: Pre-purge speed test

Controller sends and receives signal to / from fan speed controller to verify maximum rpm of the blower.

Phase 3: Pre-purge

Pre-purge cycle starts within the pre-programmed timing. Pre-purge timing is in addition to previous phase (2). The fan speed must be greater than and within the range of rpm requested by the controller.

Phase 4: Pre-ignition

The ignition spark is initiated and controlled.

Phase 5: Ignition / safety timing / flame stabilization

The gas valve opens during the safety timing period (4 seconds). If a flame is detected, this phase ends immediately in < 1.5 seconds. If the flame is not established after 3 trials, the burner will lock out and will require a manual reset. Controller required time for flame stabilization.

Phase 6: Burner modulation operation or calibration

At the end of the flame stabilization period (4.5 seconds), a release for modulation occurs and the burner temperature controller will take over from the flame safeguard. Forced shutdown after 24 hours continuous operation. Automatic calibration may be initiated by the controller.

Phase 7: Combination gas valve proof of closure test

If during the normal operation of the burner a controlled (or uncontrolled) shut-down occurs, a complete mechanical and electrical gas valve proof of closure test will be performed by the flame safeguard. After a successful mechanical and electrical proof of closure test, the flame safeguard will expect that the flame is not present. If, however, the flame existed for a period of > 15 seconds, the flame safeguard will go into permanent lock-out.

Phase 8: Post-purge speed test

Both gas valves are closed during this phase. End call for heat. Post-purge occurs during the programmed period.

Phase 9: Additional post-purge

If the fixed high limit trips during normal operation, the blower will purge for 15 minutes to cool the heat exchanger.

Parts Lists

Model No.	Serial No.
B2HA 112, 399 Boiler	7510835□□□□□□□□
	7550393□□□□□□□□
B2HA 150, 530 Boiler	7510836□□□□□□□□
	7550394□□□□□□□□

Ordering Replacement Parts:

Please provide model no. from rating plate (A) and serial no. when ordering replacement parts. Order replacement components from your Viessmann distributor.

Parts for Main Enclosure Assembly

- 0001 Cover panel
- 0002 Control housing
- 0003 Mounting rail, left
- 0004 Mounting rail, right
- 0005 Cover panel for electronics
- 0006 Support bracket, left
- 0007 Support bracket, right
- 0008 Cover panel
- 0009 Mounting clip (Set of 2)
- 0010 Nameplate
- 0011 Electrical box
- 0012 Electrical box cover
- 0013 Support bracket for panel
- 0014 Grommet for p-trap
- 0015 Wall-mount bracket

Other Parts (not illustrated)

- 0401 Touch-up spray paint "Vitowhite"
- 0402 Touch-up paint stick "Vitowhite"
- 0403 Lubricant 6g

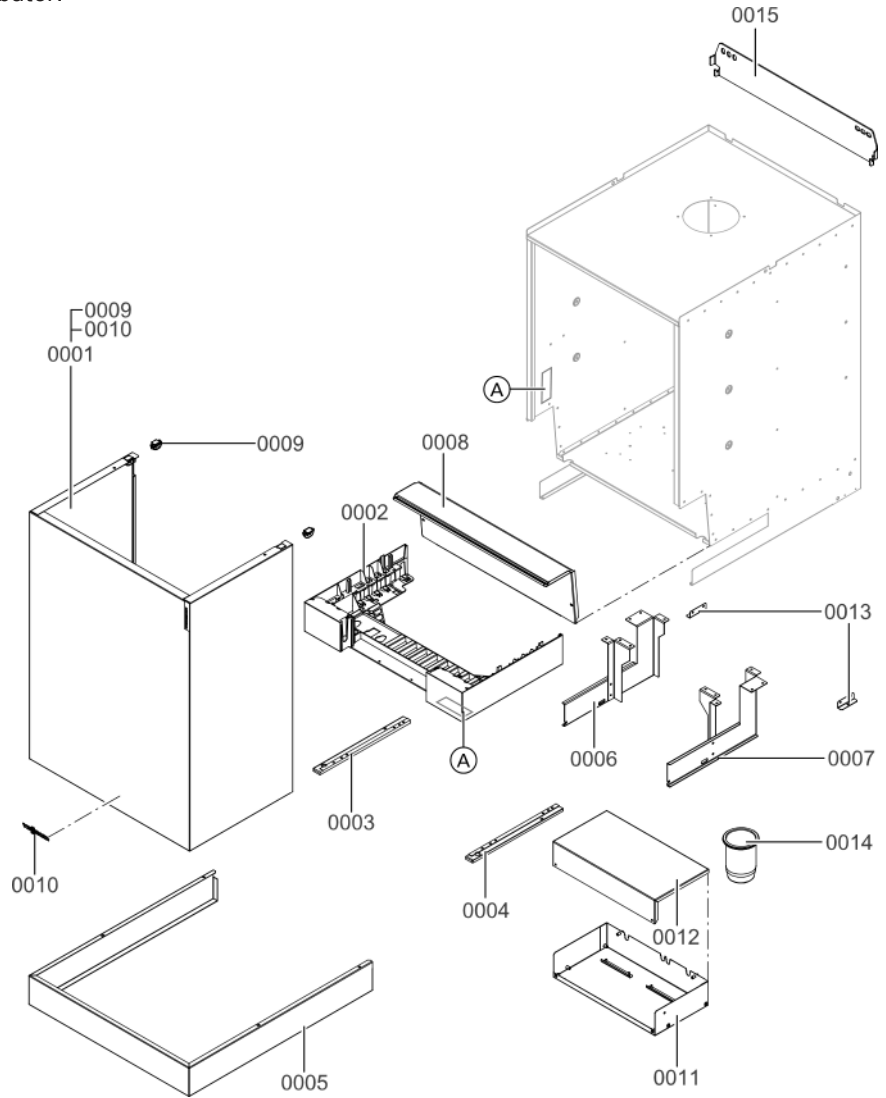

Parts Lists *(continued)*

Model No.	Serial No.
B2HA 112, 399 Boiler	7510835□□□□□□□□
	7550393□□□□□□□□
B2HA 150, 530 Boiler	7510836□□□□□□□□
	7550394□□□□□□□□

Ordering Replacement Parts:

Please provide model no. from rating plate and serial no. when ordering replacement parts. Order replacement components from your Viessmann distributor.

Parts for Pressure Vessel Assembly

- 0001 Heat exchanger assembly with piping
- 0002 Gas valve CES-Big, 120/1/60
- 0003 MatriX cylinder burner assembly
- 0004 Vent pipe adaptor 110/150
- 0005 Flue gas sensor
- 0006 Combustion chamber door refractory
- 0007 Gasket, D = 150 mm for air intake
- 0008 Gasket, DN110 for flue gas
- 0009 Connection flange with gas ball valve
- 0010 Grommet, DN110 for flue gas
- 0011 Test port cap (Set of 2)
- 0012 P-Trap
- 0013 Condensate drain kit
- 0014 Flex pipe for gas
- 0015 Gas connection pipe
- 0016 Condensate hose
- 0017 Gasket, A32x44x2 mm (Set of 5)
- 0018 Gasket 1 in. (Set of 5)
- 0019 Gasket, 1 ¼ in. (Set of 5)

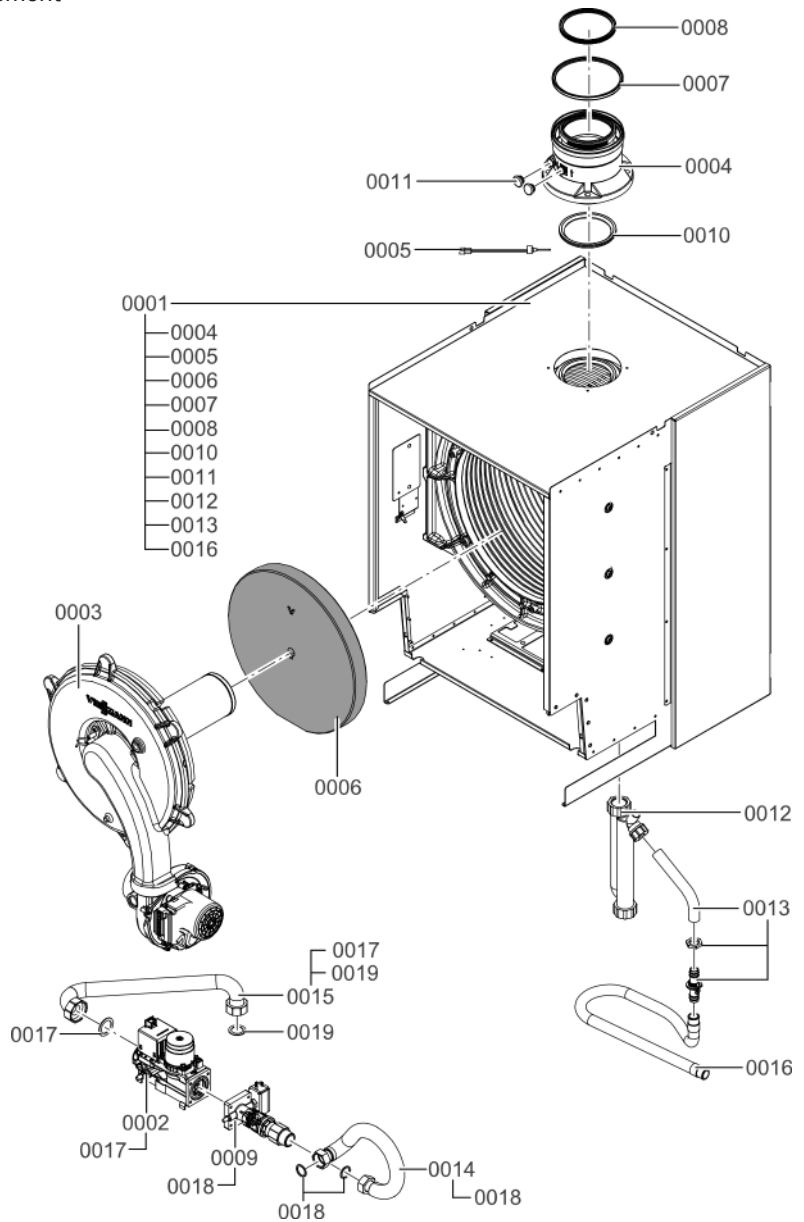

Parts Lists *(continued)*

Model No.	Serial No.
B2HA 112, 399 Boiler	7510835□□□□□□□□
	7550393□□□□□□□□
B2HA 150, 530 Boiler	7510836□□□□□□□□
	7550394□□□□□□□□

Ordering Replacement Parts:

Please provide model no. from rating plate and serial no. when ordering replacement parts. Order replacement components from your Viessmann distributor.

Parts for Burner Assembly

- 0001 Burner gasket, D408 mm
- 0002 Combustion chamber door refractory
- 0003 Burner tube, NG/LP
- 0004 Gasket for burner tube
- 0005 Burner mounting flange assembly
- 0006 Radial fan, NRG137
- 0007 Ionization electrode
- 0008 Ignition electrode with gasket
- 0009 Gasket for ignition electrode
- 0010 Gasket for ionization electrode
- 0011 Flapper
- 0012 Bracket (Set of 6)
- 0013 Ignition module

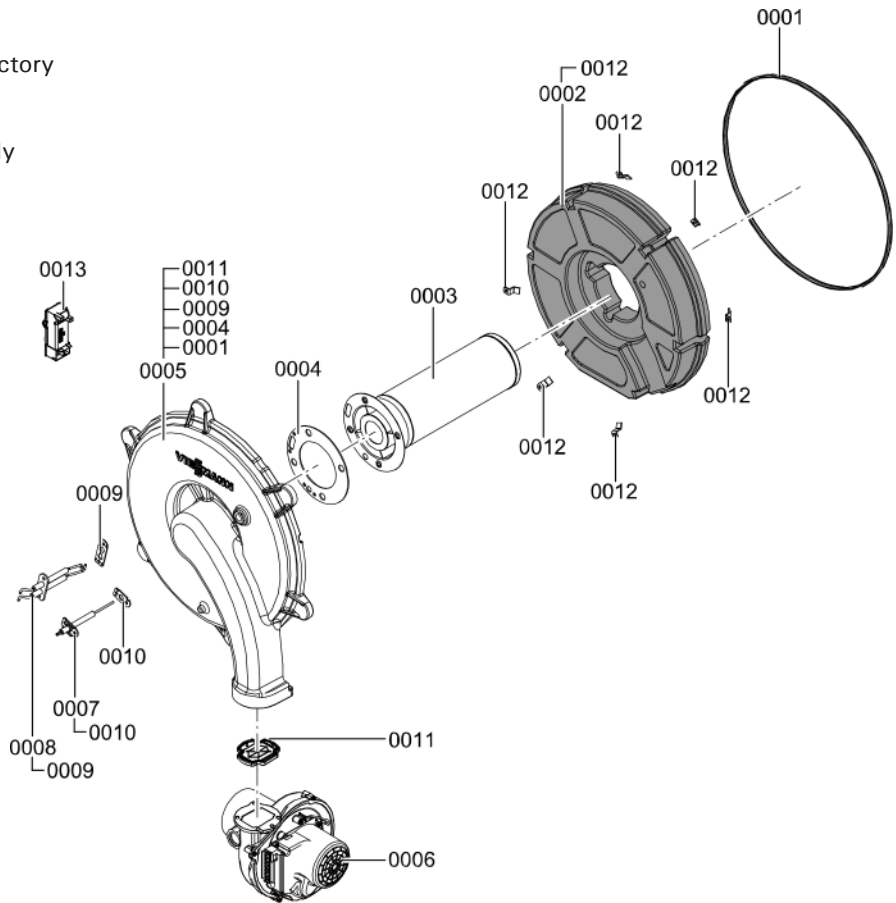

Parts Lists *(continued)*

Model No.	Serial No.
B2HA 112, 399 Boiler	7510835□□□□□□□□□□
	7550393□□□□□□□□□□
B2HA 150, 530 Boiler	7510836□□□□□□□□□□
	7550394□□□□□□□□□□

Ordering Replacement Parts:

Please provide model no. from rating plate and serial no. when ordering replacement parts. Order replacement components from your Viessmann distribut

Parts for Control Assembly

- 0001 Control console
- 0002 Control housing, rear
- 0003 Coding plug
- 0004 Fuse, 6.3A/250V (Pkg of 10)
- 0005 Fuse holder
- 0007 Vitotronic 200 HO1B
- 0008 LON communication module HO1B
- 0009 Circuit board (LON module adaptor)
- 0010 Cable harness X8/X9/ioniz.
- 0011 Cable harness 100/35/54/PE
- 0012 Cable harness GDW1/GDW2
- 0013 Counter plug, Neptune
- 0014 Cable strain relief (Set of 10)
- 0015 Locking assembly (left/right)
- 0016 Outdoor temperature sensor, NTC
- 0017 Circuit board for internal expansion
- 0020 Power/pump control module
- 0021 Extension module EA1, 120/1/60
- 0022 Fuse, 2.0A/250V (Pkg of 10)
- 0023 Harness set, ppc module

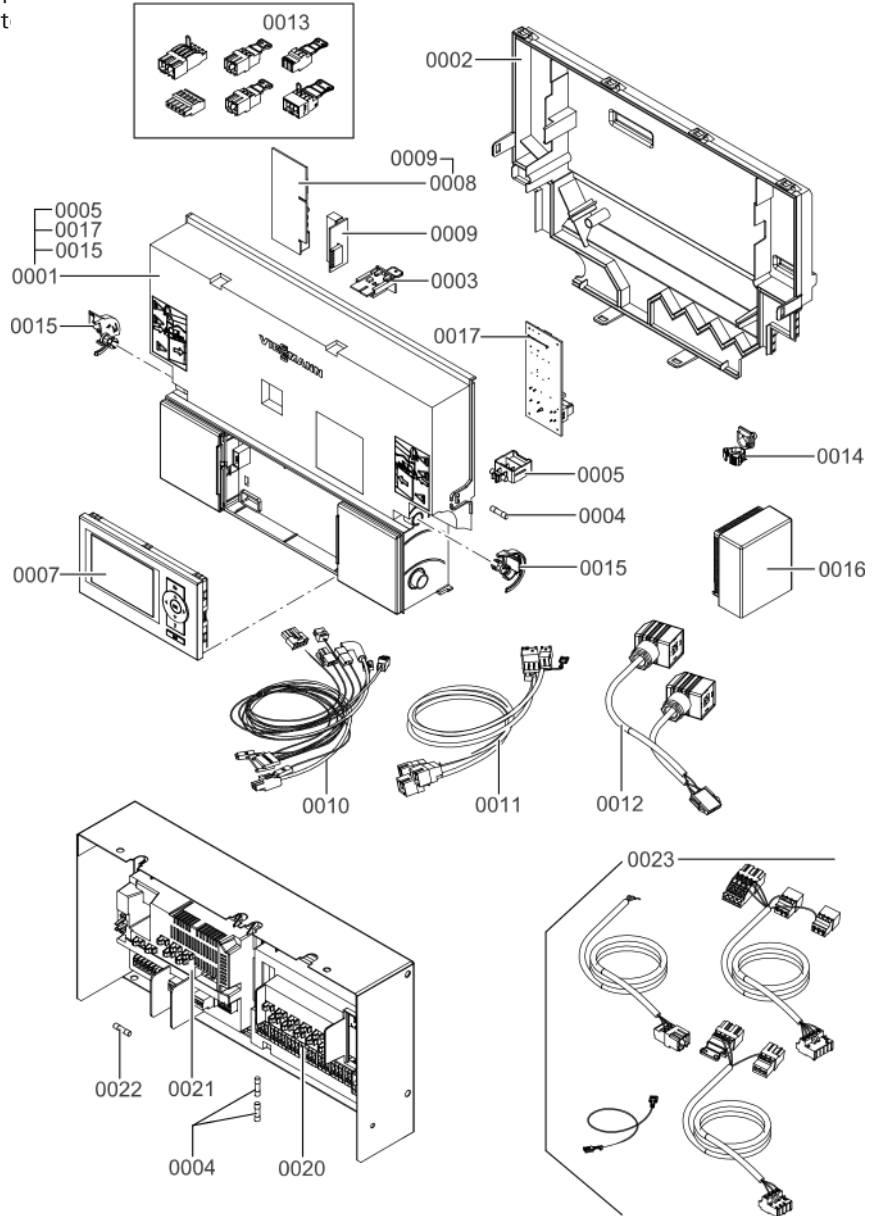

Parts Lists *(continued)*

Model No.	Serial No.
B2HA 112, 399 Boiler	7510835□□□□□□□□
	7550393□□□□□□□□
B2HA 150, 530 Boiler	7510836□□□□□□□□
	7550394□□□□□□□□

Ordering Replacement Parts:

Please provide model no. from rating plate and serial no. when ordering replacement parts. Order replacement components from your Viessmann distributor.

Parts for Hydronic Assembly

- 001 Clip D8 mm (Set of 5)
- 002 Boiler temperature sensor (Set of 2)
- 003 Pressure gage with clip and gasket
- 004 Flow sensor

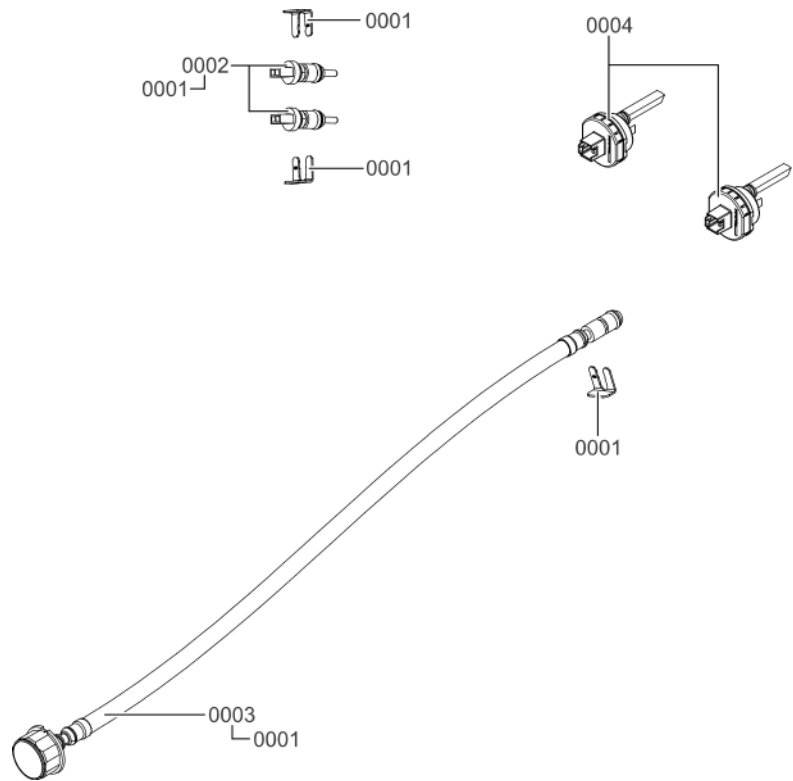

Technical Data

Boiler Model No. B2HA		112, 399	150, 530 *A
CSA input Natural Gas (NG)	MBH (kW)	113-399 (33-117)	113-530 (33-155)
CSA input Liquid Propane Gas (LPG)	MBH (kW)	113-399 (33-117)	113-530 (33-155)
CSA output NG *3	MBH (kW)	103-375 (30-110)	103-495 (30-145)
CSA output LPG *3	MBH (kW)	103-375 (30-110)	103-495 (30-145)
DOE/AHRI Gross output	MBH (kW)	371 (109)	490 (144)
Net AHRI Rating *B	MBH (kW)	323 (95)	426 (125)
Heat exchanger surface area	ft. ² (m ²)	36.78 (3.41)	36.78 (3.41)
Min. gas supply pressure			
Natural gas	"w.c.	4	4
Liquid propane gas	"w.c.	10	10
Max. gas supply pressure *1			
Natural gas	"w.c.	14	14
Liquid propane gas	"w.c.	14	14
ANSI Z21, 13/CSA 4.9			
Thermal efficiency	%	93.9	93.5
AHRI, BTS-2000 *C			
Combustion efficiency	%	93.5	93.0
Thermal efficiency	%	93.0	92.5
Weight	lbs (kg)	298 (135)	298 (135)
Boiler water content	USG (L)	4 (15)	4 (15)
Boiler max. flow rate *2	GPM (L/h)	38 (8600)	38 (8600)
Max. operating pressure at 210° F (99° C)	psig (bar)	80 (5.5)	80 (5.5)
Boiler water temperature			
- Adjustable high limit (AHL) range space heating (steady state)	°F (°C)	68 to 185 (20 to 85)	68 to 185 (20 to 85)
DHW production	°F (°C)	185 (85)	185 (85)
- Fixed high limit (FHL)	°F (°C)	210 (99)	210 (99)
Boiler connections			
Boiler heating supply and return	NPTM	2 in.	2 in.
Pressure relief valve	NPTF	¾ in.	¾ in.
Drain valve	(male thread)	¾ in.	¾ in.
Boiler supply/return for indirect-fired DHW storage tank (field supplied)	NPT	2 in.	2 in.
Gas valve connection	NPTF	1 in.	1 in.

*A For high altitude installations 5,000 - 10,000 ft. (1500 m - 3000 m), the input for model B2HA 150, 530 will have an altitude de-rating of 14% for 5,000 ft. (1500 m) and 29% for 10,000 ft. (3000 m) average of 2.8% / 1,000 ft. (305 m). The input for model B2HA 112, 399 at 10,000 ft. (3000 m) will have an input de-rate of 13%.

*B Net AHRI rating based on piping and pick-up allowance of 1.15.

*C Tested to AHRI, BTS-2000 Testing Standard Method to Determine Efficiency of Commercial Heating Boilers.

*1 If the gas supply pressure exceeds the maximum gas supply pressure value, a separate gas pressure regulator must be installed upstream of the heating system.

*2 See "Waterside Flow" in the Installation Instructions.

*3 Output based on 180°F (82°C), 80°F (26°C) system supply/return temperature.

Technical Data *(continued)*

Boiler Model No. B2HA		112, 399	150, 530 *A
Dimensions			
Overall depth	inches (mm)	27.1 (689)	27.1 (689)
Overall width	inches (mm)	23 ⁵ / ₈ (600)	23 ⁵ / ₈ (600)
Overall height	inches (mm)	44½ (1128) *8	44½ (1128) *8
Flue gas *4			
Temperature (at boiler return temperature of 86°F (30°C)			
- at rated full load	°F (°C)	124 (51)	140 (60)
- at rated partial load	°F (°C)	102 (39)	102 (39)
Temperature (at boiler return temperature of 140°F (60°C)	°F (°C)	158 (70)	165 (74)
Max. condensate flow rate *5 for NG and LPG T _S /T _R = 104/86°F (40/30°C)			
	USG/h (L/h)	4.35 (16.5)	5.28 (20.0)
Condensate connection *6			
	hose nozzle Ø in.	¾-1	¾-1
Boiler flue gas connection *7			
	Ø in. (mm)	4 ³ / ₈ (110)	4 ³ / ₈ (110)
Combustion air supply connection (coaxial)			
	outer Ø in. (mm)	6 (150)	6 (150)
Sound Rating			
- at maximum input	dB	57	61
- at minimum input	dB	40	40
NOx @ 3% O ₂		< 20 PPM *9	

*A For high altitude installations 5,000 - 10,000 ft. (1500 m - 3000 m), the input for model B2HA 150, 530 will have an altitude de-ration of 14% for 5,000 ft. (1500 m) and 29% for 10,000 ft. (3000 m) average of 2.8% / 1,000 ft. (305 m). The input for model B2HA 112, 399 at 10,000 ft. (3000 m) will have an input de-rate of 13%.

*4 Measured flue gas temperature with a combustion air temperature of 68°F (20°C).

*5 Based on maximum input rate.

*6 Requires 1 inch (25 mm) tubing. See the Installation Instructions of the Vitodens 200-W, B2HA for details.

*7 For side wall vent installations (coaxial system):
Do not exceed max. equivalent length specified in the Installation Instructions of the Vitodens 200-W, B2HA Venting System.
Do not attempt to common-vent Vitodens 200-W with any other appliance.
Side wall co-axial vent installation must include Viessmann protective screen!
For details refer to the Installation Instructions for the Vitodens 200-W, B2HA Venting System.

*8 Add approximately 2½ inches (65 mm) for coaxial vent pipe transition adaptor.

*9 Optional low NOx certified by SCAQMD Natural Gas models available.

For information regarding other Viessmann System Technology componentry, please reference the documentation of each respective product.

Maintenance Record

Measurements		Service date: by:	Service date: by:	Service date: by:	Service date: by:	Service date: by:	Service date: by:	Setpoint value
Static pressure	"w.c.							max. 14 "w.c.
Running pressure (supply pressure)								
<input type="checkbox"/> Natural gas	"w.c.							4-14 "w.c.
<input type="checkbox"/> LPG	"w.c.							10-14 "w.c.
<i>Check gas type</i>								
Carbon dioxide content CO₂								
<input checked="" type="checkbox"/> at lower end of rated input range	vol.-%							
<input checked="" type="checkbox"/> at upper end of rated input range	vol.-%							
Oxygen content O₂								
<input checked="" type="checkbox"/> at lower end of rated input range	vol.-%							
<input checked="" type="checkbox"/> at upper end of rated input range	vol.-%							
Carbon monoxide content CO								
<input checked="" type="checkbox"/> at lower end of rated input range	ppm							50 ppm air-free*
<input checked="" type="checkbox"/> at upper end of rated input range	ppm							
Ionization current	µA							

*Fuel type, altitude, venting and other site parameters may change

Lighting and Operating Instructions

FOR YOUR SAFETY READ BEFORE OPERATING

W A R N I N G: If you do not follow these instructions exactly, a fire or explosion may result causing property damage, personal injury or loss of life.

- A. This appliance does not have a pilot. It is equipped with an ignition device which automatically lights the burner. Do not try to light the burner by hand.
- B. **BEFORE OPERATING** smell all around the appliance area for gas. Be sure to smell next to the floor because some gas is heavier than air and will settle on the floor.
WHAT TO DO IF YOU SMELL GAS
- Do not try to light any appliance.
 - Do not touch any electric switch; do not use any phone in your building.
 - Immediately call your gas supplier from a neighbor's phone. Follow the gas supplier's instructions.
 - If you cannot reach your gas supplier, call the fire department.
- C. Use only your hand to push in or turn the gas control knob. Never use tools. If the knob will not push in or turn by hand, don't try to repair it, call a qualified service technician. Force or attempted repair may result in a fire or explosion.
- D. Do not use this appliance if any part has been under water. Immediately call a qualified service technician to inspect the appliance and to replace any part of the control system and any gas control which has been under water.

OPERATING INSTRUCTIONS

1. **STOP!** Read the safety information above on this label.
2. Set thermostat or other operating control to lowest setting.
3. Turn off all electric power to the appliance.
4. This appliance is equipped with an ignition device which automatically lights the burner. Do not try to light the burner by hand.
5. Close main gas shut-off valve.
6. Wait five (5) minutes to clear out any gas. Then smell for gas, including near the floor. If you smell gas, **STOP!** Follow "B" in the safety information above on this label. If you don't smell gas, go to the next step.
7. Open main gas shut-off valve.
8. Turn on all electric power to the appliance.
9. Set thermostat or other operating control to desired setting.
10. If the appliance will not operate, follow the instructions "To Turn Off Gas To Appliance" and call your service technician or gas supplier.

Manual gas shutoff

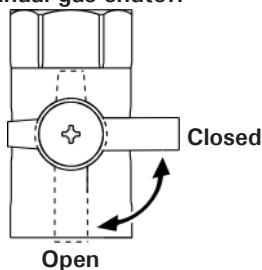

TO TURN OFF GAS TO APPLIANCE

1. Set thermostat or other operating control to lowest setting.
2. Turn off all electric power to the appliance if service is to be performed.
3. Close main gas shut-off valve.

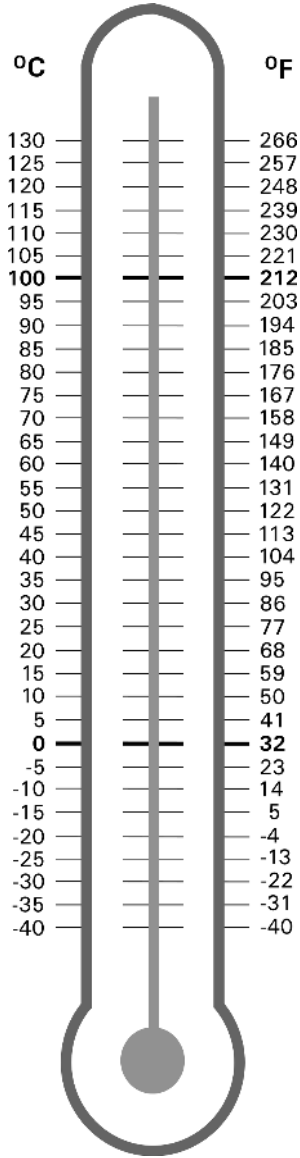

Technical information subject to change without notice.

Viessmann Manufacturing Company Inc.
750 McMurray Road
Waterloo, Ontario • N2V 2G5 • Canada
TechInfo Line 1-888-484-8643
1-800-387-7373 • Fax (519) 885-0887
www.viessmann.ca • info@viessmann.ca

Viessmann Manufacturing Company (U.S.) Inc.
45 Access Road
Warwick, Rhode Island • 02886 • USA
TechInfo Line 1-844-649-5886
1-800-288-0667 • Fax (401) 732-0590
www.viessmann-us.com • info@viessmann-us.com