



**GAS CONDENSING TECHNOLOGY**

High output gas condensing boilers  
**VITODENS 200-W**



**VITODENS 200-W**

- 5 year warranty for Viessmann Trained Installers
- Option to increase to 10 years
- Vitodens 200-W 60 kW reviewed as a Which? Best Buy



# VIESSMANN



The Vitodens 200-W is a wall hung gas condensing boiler for commercial applications, available in 49, 60, 80, 99, 120, 150 kW models. This brochure contains information about the individual boilers, cascade solutions, boiler controls and the accessories needed for a successful and efficient installation.



Vitodens 200-W 49-99 kW

from page 4



Vitodens 200-W 120 and 150 kW

from page 6



Cascade packages

from page 8



Flue options

page 11



Boiler controls

page 18

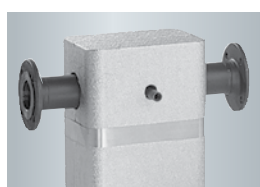

Boiler accessories

from page 20



Heating circulation pumps

page 22



Divicons

from page 22

High output gas  
condensing boilers

**VITODENS 200-W**  
49 to 99 kW, cascade up to 594 kW



**VITODENS 200-W**  
60 kW System

The Vitodens 200-W high output gas condensing boiler is one of the most efficient and reliable boilers for commercial use. High efficiency pumps are now available as standard. Available in cascade solutions up to 594 kW with 6 units.

The 49 to 99 kW range of Vitodens 200-W gas condensing boilers feature easy installation, optional cascade, weather compensation and high efficiency pump as standard.

#### Take advantage of these benefits

- Gross efficiency up to 98%
- NOx credit rating 4 (<39mg/kWh) according to BREEAM
- Noise emission of less than 39dB (A)
- Cascade up to 594 kW with 6 units
- Additional fuel savings of up to 15% with optional weather compensation
- Up to 4Bar operating pressure
- High efficiency pumps available as standard

#### MatriX cylinder burner

- Modulation range of 1:5
- Patented technology manufactured by Viessmann
- Low NOx and CO emissions
- Stainless steel MatriX mesh ensures long term reliability

#### Inox-Radial heat exchanger

- Excellent corrosion resistance through high grade stainless steel (type SS 1.4571)
- Self-cleaning smooth stainless steel surface
- 10 year warranty against corrosion

#### Lambda Pro combustion controller

- No nozzle change when converting to LPG
- Consistently high efficiency even with fluctuating gas composition and air pressure
- Constantly clean combustion
- Low combustion noise through low fan speed
- Optimised efficiency throughout its life
- Simple and failsafe commissioning of the boiler

#### Controls

- Vitotronic 200
- Remote data communication and monitoring
- Solar / heat pump interface
- Safety monitor sensors
- Automatic commissioning functions
- Optional weather compensation

#### NEW pump connection sets

- Smaller connection sets for single boiler use
- Connection set includes low loss header
- Quick and easy installation
- Reduced hydraulic intersections
- Higher installation flexibility due to less space needed and installation frame with left/right wall/frame installation options
- Made and patented by Viessmann

#### Warranties

- 2 year comprehensive warranty as standard
- 5 year comprehensive warranty if fitted by a Viessmann Trained Installer
- 10 year extended warranty option when registered through the Viessmann Installer Portal ([www.viessmanninstallerportal.co.uk](http://www.viessmanninstallerportal.co.uk)) for 49 & 60 kW models. For 80 to 150 kW models please contact your Area Business Manager.

#### Training courses

- The Vitodens 200-W commercial course is over one day. Accommodation and lunch can be provided on request at Telford.
- Vitodens 200-W range and controls
  - Commercial applications including wiring systems, using mixers & low loss headers and cascade controls

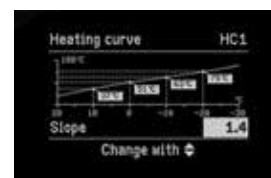

Example: Vitotronic 200 HO1B heating curve

### 10 Year Warranty

on all stainless steel heat exchangers for gas condensing boilers up to 150 kW

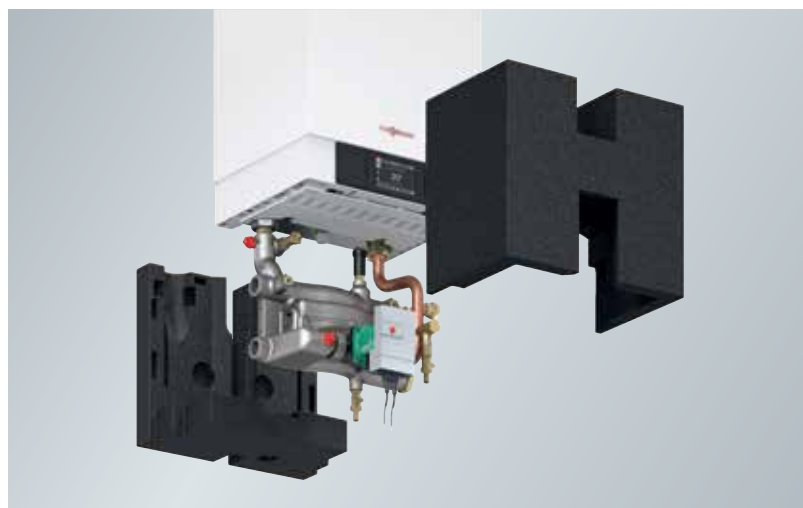

Vitodens 200-W with new pump connection set, for single boilers from 49 to 150 kW

High output gas  
condensing boilers

**VITODENS 200-W**  
120 to 150 kW, cascade up to 900 kW



The new Vitodens 200-W B2HA models, with output from 120 to 150 kW. A high performance range with output up to 900 kW with a 6 unit cascade. High efficiency pumps are now available as standard.

The Vitodens 200-W is loaded with features and functions to make installation, fault-finding and servicing easy.

Featuring compact design, quiet operation and easy installation, the 120 and 150 kW units offer a new level in performance for commercial applications.

#### Take Advantage of these benefits

- Gross efficiency up to 98%
- NOx credit rating 4 (<39mg/kWh) according to BREEAM
- Noise emission of less than 40dB (A)
- Cascade up to 900 kW with 6 units
- Additional fuel savings of up to 15% with optional weather compensation
- Up to 6Bar operating pressure
- High efficiency pumps available as standard
- Compact design – 150 kW on 0.50m<sup>2</sup> footprint
- Suitable for buildings with up to 18 floors

#### MatriX cylinder burner

- Modulation range of 1:5
- Patented technology manufactured by Viessmann
- Low NOx and CO emissions
- Stainless steel MatriX mesh ensures long term reliability and service life
- Patented technology, manufactured by Viessmann
- Optimum matching of heat exchanger and burner

#### Inox-Radial heat exchanger

- Excellent corrosion resistance through high grade stainless steel (type SS 1.4571)
- Self-cleaning smooth stainless steel surface
- 10 year warranty against corrosion

#### Lambda Pro combustion controller

- No nozzle change when converting to LPG
- Consistently high efficiency even with fluctuating gas composition and air pressure
- Constantly clean combustion
- Low combustion noise through low fan speed
- Optimised efficiency throughout its life
- Simple and failsafe commissioning of the boiler

#### Controls

- Vitotronic 200
- Remote data communication and monitoring
- Solar / heat pump interface
- Safety monitor sensors
- Automatic commissioning functions
- Optional weather compensation

#### NEW pump connection sets

- Smaller connection sets for single boiler use
- Connection set includes low loss header
- Quick and easy installation
- Reduced hydraulic intersections
- Higher installation flexibility due to less space needed and installation frame with left/right wall/frame installation options
- Made and patented by Viessmann

#### Warranties

- 2 year comprehensive warranty as standard
- 5 year comprehensive warranty if fitted by a Viessmann Trained Installer
- 10 year extended warranty option when registered through the Viessmann Installer Portal ([www.viessmanninstallerportal.co.uk](http://www.viessmanninstallerportal.co.uk)) for 49 & 60 kW models. For 80 to 150 kW models please contact your Area Business Manager.

#### Training courses

The Vitodens 200-W commercial course is over one day. Accommodation and lunch can be provided on request at Telford.

- Vitodens 200-W range and controls
- Commercial applications including wiring systems, using mixers & low loss headers and cascade controls



Inox-Radial heat exchanger

### 10 Year Warranty

on all stainless steel heat exchangers for gas condensing boilers up to 150 kW

High output gas  
condensing boilers

## VITODENS 200-W

Compact cascade system



Cascade frame for 49 to 99 kW models



Cascade frame for 120 & 150 kW models

Fitting Viessmann commercial boilers has never been easier, thanks to the new Vitodens 200-W compact cascade system. Available on the 49, 60, 80 and 99 kW Vitodens 200-W models, the compact cascade system saves significant space within the plant room and halves installation time.

Now 30% smaller than the previous cascade configuration, it is perfect for plant rooms with lower footprints or with a small headroom, as the boiler height can be adjusted on the frame. Suitable for row, block or even corner installations, the compact cascade can be wall mounted or simply fitted with a free-standing frame for 2,3,4,5 or 6 boiler units at a time. This can deliver a maximum output of 594 kW with a 6 boiler cascade.

The easy to assemble cascade will save up to 50% on the installation time thanks to a refined design and brand new fully preassembled heating circuit connection set. This integrates the flow and return cascade, 4 bar safety valve, ball cocks and draining all within a single connection set, which can be easily fitted to the frame or wall mount.

Additional 120 and 150 kW Vitodens 200-W models are also available with a separate cascade system.

- 30% smaller than previous configurations
- Adjustable boiler height on cascade frame
- Save up to 50% on installation time
- New preassembled heating circuit connection set
- Available on 49 - 99 kW Vitodens 200-W models
- Cascade 2,3,4,5 or 6 boilers up to 594 kW

Watch the installation guide on the  
'Viessmann Installer' YouTube channel

#### Vitodens 200-W, Cascade - New mounting frame with height adjustment

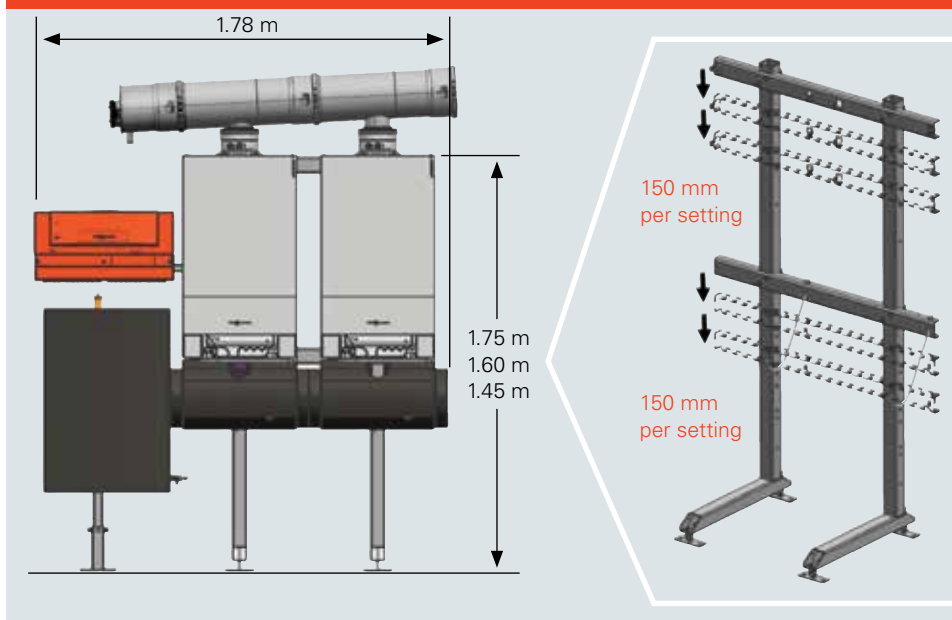

## High output gas condensing boilers

The Vitodens 200-W can be cascaded with up to 6 units, offering outputs up to 594 kW. Viessmann's comprehensive cascade packages are designed for easy installation on all applications.

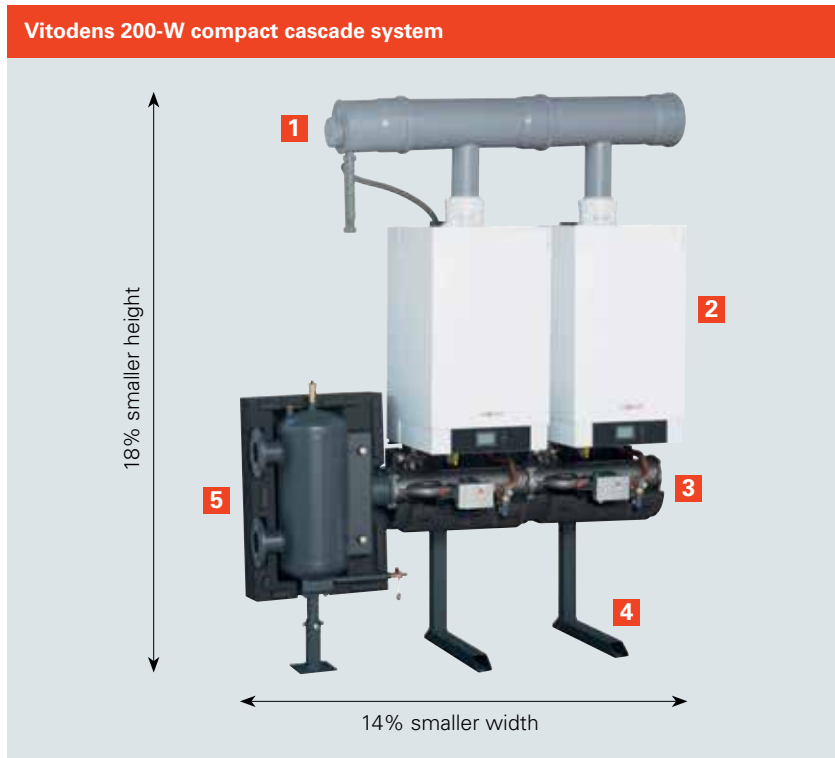

### Vitodens 200-W compact cascade system

- 1 Flue gas cascade
- 2 Vitodens 200-W gas condensing boiler
- 3 Heating circuit connection set
- 4 Cascade frame or wall bracket
- 5 Low loss header

### Cascade Specifications

- Maximum installed flue height  
With frame and gas header: 2 metres  
Without frame: 1.8 metres
- Minimum installed flue height  
With frame and gas header: 1.7 metres  
Without frame: 1.5 metres

Watch the installation guide on the  
'Viessmann Installer' YouTube channel

Number of boilers			2	3	4	5	6
<b>Heating circuit connection</b>							
Low loss header		PN6/DN	80	80	80	80	80
Cascade module adaptor		PN6/DN	100	100	100	100	100
<b>Boiler connection</b>							
		G	1½	1½	1½	1½	1½
<b>Max. flow rate</b>							
	<b>t</b>						
- 49 kW	15 K	m <sup>3</sup> /h	5.6	8.4	11.2	14.0	16.8
- 60 kW	15 K	m <sup>3</sup> /h	6.9	10.3	13.8	17.2	20.6
- 80 kW	20 K	m <sup>3</sup> /h	6.9	10.3	13.7	17.2	20.6
- 99 kW	20 K	m <sup>3</sup> /h	8.5	12.8	17.0	21.3	25.5
<b>Circulation pump</b>							
		Type		Vi Para 25/1-11			
Rated voltage		V		230			
Max. power consumption		W		140			
Min. power consumption		W		8			

INDIVIDUAL BOILER FLUE INFORMATION

	Output	Flue diameter (mm)	Max. flue length (m)					
			Balanced flue diameter (mm)	Duct open flue	Roof outlet	Ext. wall terminal	Routing over ext. wall	Duct balanced flue
<b>Concentric flue</b>	49 kW		80/125		10	10	12	20
	60 kW		80/125		6	6	12	15
	80 kW		100/150		15	15	20	20
	99 kW		100/150		15	15	20	20
	120 kW		100/150		8	8	18	8
	150 kW		100/150		5	5	15	5
<b>Conventional flue</b>	49 kW	80		25				
	60 kW	80		15				
	80 kW	100		20				
	99 kW	100		20				
	120 kW	100		20				
	150 kW	100		20				

CASCADE FLUE INFORMATION

Flue gas cascade type each kit comprising: Flue gas non-return device, flue pipe, terminal with condensate drain and boiler coding card.

	Diagram	49 - 60 kW		80 - 99 kW		120 - 150 kW	
		Dia. (mm)	Max. flue length (mm)	Dia. (mm)	Max. flue length (mm)	Dia. (mm)	Max. flue length (mm)
<b>Flue gas cascade twin</b>		80/160	30	100/200	30	110/250	30
<b>Flue gas cascade triple</b>		80/160	30	100/200 110/250	30	100/250	30
<b>Flue gas cascade quad</b>		80/200	30	100/200	30	100/250	16
<b>Flue gas cascade five</b>		80/250	30	100/250	30		
<b>Flue gas cascade six</b>		80/250	30	100/250	30	100/250	9
<b>Flue gas cascade quad block</b>		80/200	30	100/250	30		
<b>Flue gas cascade six block</b>		80/250	30	100/250	30		

Wall mounting with low loss header

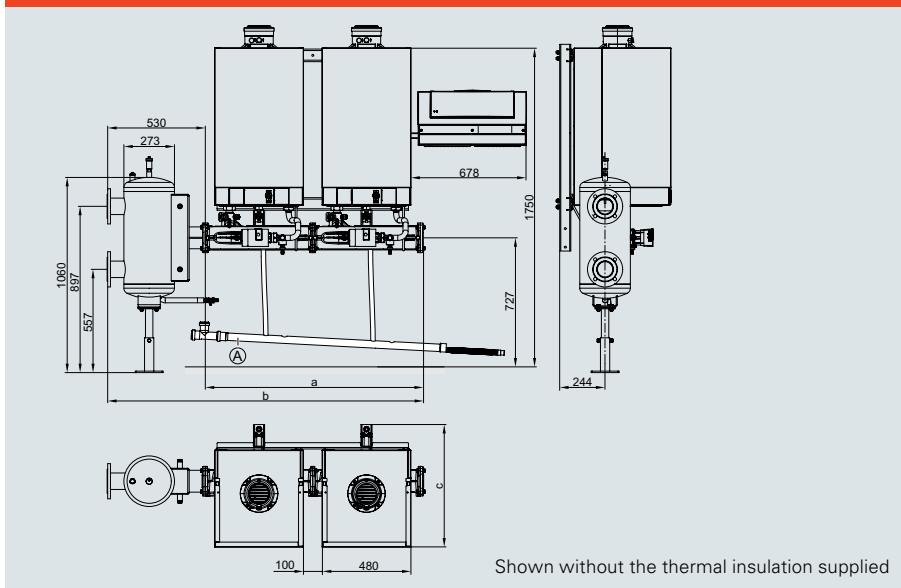

Ⓐ CONDENSATE HEADER (ACCESSORIES)

Number of boilers		2		3		4		5		6	
Rated heating output	kW	49 - 60	80 - 99	49 - 60	80 - 99	49 - 60	80 - 99	49 - 60	80 - 99	49 - 60	80 - 99
a	mm	1190	1190	1770	1770	2350	2350	2930	2930	3510	3510
b	mm	1720	1720	2300	2300	2880	2880	3460	3460	4040	4040
c	mm	511	661	511	661	511	661	511	661	511	661

**Note**

The height dimensions can be reduced by max. 150 mm. In this case, the fixing profiles must be installed accordingly.

Wall mounting with a cascade module adaptor (without low loss header)

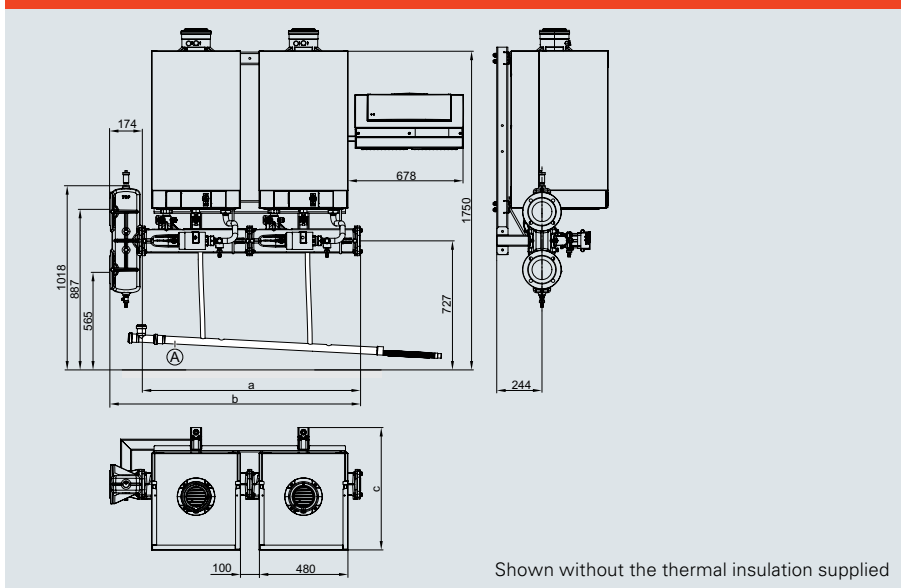

Ⓐ CONDENSATE HEADER (ACCESSORIES)

Number of boilers		2		3		4		5		6	
Rated heating output	kW	49 - 60	80 - 99	49 - 60	80 - 99	49 - 60	80 - 99	49 - 60	80 - 99	49 - 60	80 - 99
a	mm	1190	1190	1770	1770	2350	2350	2930	2930	3510	3510
b	mm	1364	1364	1944	1944	2524	2524	3104	3104	3684	3684
c	mm	511	661	511	661	511	661	511	661	511	661

**Note**

The height dimensions can be reduced by max. 300 mm. In this case, the fixing profiles must be installed accordingly.

**Frame mounted installation in series with low loss header**

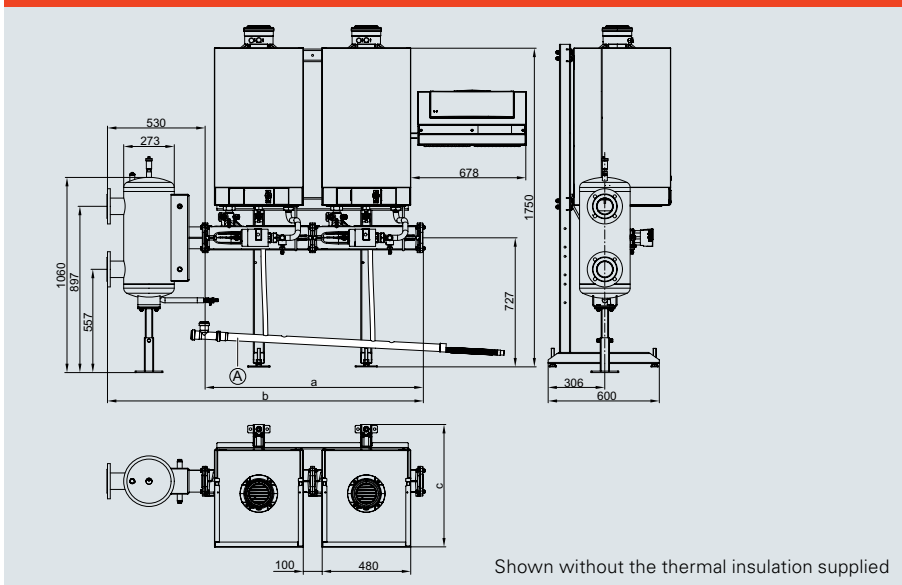

**(A) CONDENSATE HEADER (ACCESSORIES)**

Number of boilers		2		3		4		5		6	
Rated heating output	kW	49 - 60	80 - 99	49 - 60	80 - 99	49 - 60	80 - 99	49 - 60	80 - 99	49 - 60	80 - 99
a	mm	1190	1190	1770	1770	2350	2350	2930	2930	3510	3510
b	mm	1720	1720	2300	2300	2880	2880	3460	3460	4040	4040
c	mm	511	661	511	661	511	661	511	661	511	661

**Note**

The height dimensions can be reduced by 150 or 300 mm if using a mounting frame for installation. In this case, the fixing profiles must be installed accordingly.

**Installation in block formation with a low loss header**

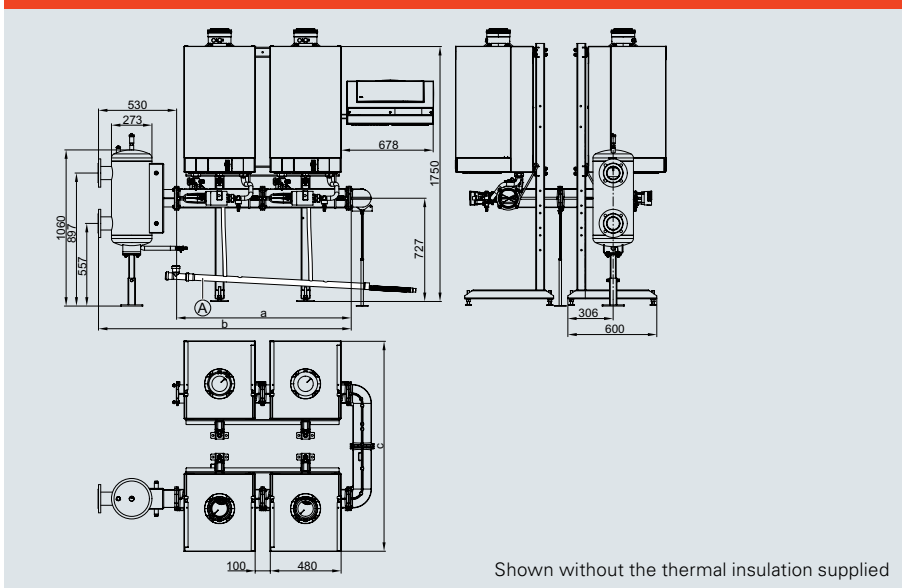

**(A) CONDENSATE HEADER (ACCESSORIES)**

Number of boilers		2 x 2		2 x 3		2 x 3		2 x 3	
Rated heating output	kW	49 - 60		80 - 99		49 - 60		80 - 99	
a	mm	1190	1190	1770	1770	1770	1770	1770	1770
b	mm	1720	1720	2300	2300	2300	2300	2300	2300
c	mm	1350	1422	1422	1422	1350	1350	1350	1422

**Note**

The height dimensions can be reduced by 150 or 300 mm if using a mounting frame for installation. In this case, the fixing profiles must be installed accordingly.

Installation in series with a cascade module adaptor (without low loss header)

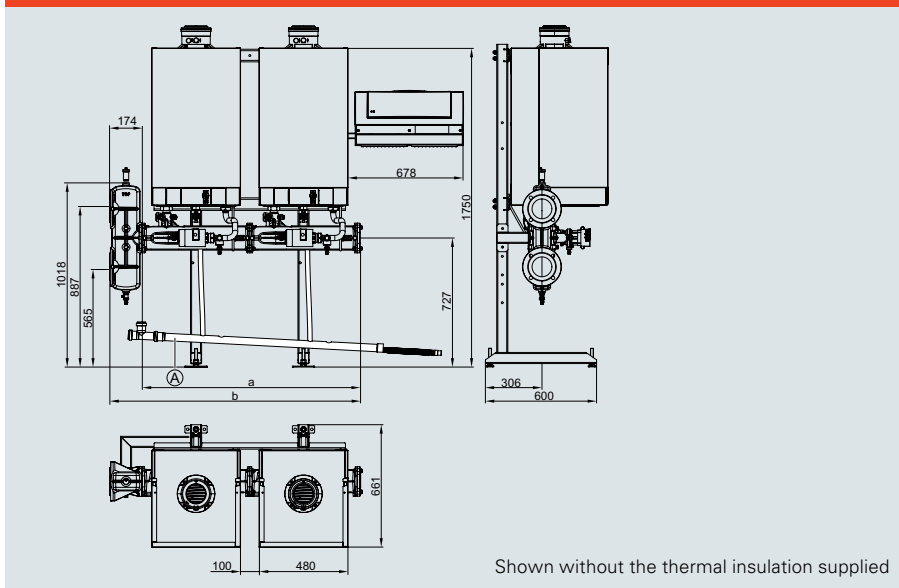

Ⓐ CONDENSATE HEADER (ACCESSORIES)

Number of boilers		2		3		4		5		6	
Rated heating output	kW	49 - 60	69 - 99	49 - 60	69 - 99	49 - 60	69 - 99	49 - 60	69 - 99	49 - 60	69 - 99
a	mm	1190	1190	1770	1770	2350	2350	2930	2930	3510	3510
b	mm	1364	1364	1944	1944	2524	2524	3104	3104	3684	3684
c	mm	511	661	511	661	511	661	511	661	511	661

**Note**

The height dimensions can be reduced by 150 or 300 mm if using a mounting frame for installation. In this case, the fixing profiles must be installed accordingly.

Installation in block formation with a cascade module adaptor (without low loss header)

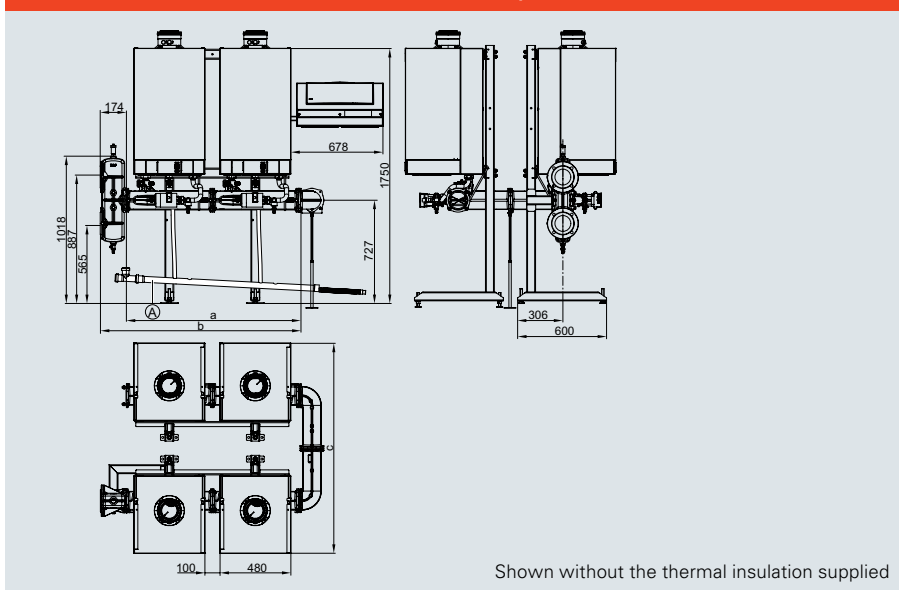

Ⓐ CONDENSATE HEADER (ACCESSORIES)

Number of boilers		2 x 2		2 x 3		2 x 3		2 x 3	
Rated heating output	kW	49 - 60		69 - 99		49 - 60		69 - 99	
a	mm	1190		1190		1770		1770	
b	mm	1364		1364		1944		1944	
c	mm	1350		1422		1350		1422	

**Note**

The height dimensions can be reduced by 150 or 300 mm if using a mounting frame for installation. In this case, the fixing profiles must be installed accordingly.

**Corner installation, multi boiler system**

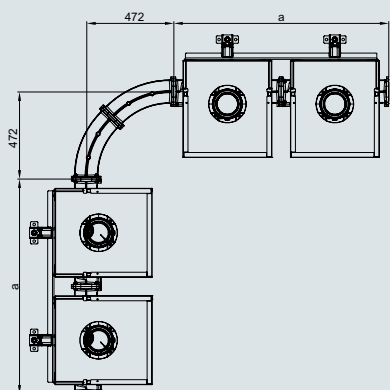

<b>Number of boilers</b>		<b>2</b>	<b>3</b>	<b>4</b>	<b>5</b>	<b>6</b>
<b>Rated heating output</b>	<b>kW</b>	<b>49 - 99</b>	<b>49 - 99</b>	<b>49 - 99</b>	<b>49 - 99</b>	<b>49 - 99</b>
<b>a</b>	<b>mm</b>	1160	1740	2320	2900	3480

**Corner installation, low loss header in a multi boiler system**

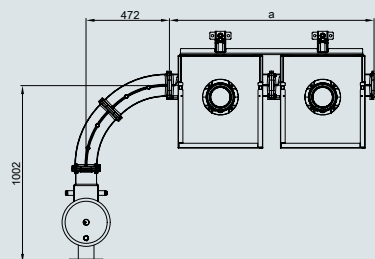

<b>Number of boilers</b>		<b>2</b>	<b>3</b>	<b>4</b>	<b>5</b>	<b>6</b>
<b>Rated heating output</b>	<b>kW</b>	<b>49 - 99</b>	<b>49 - 99</b>	<b>49 - 99</b>	<b>49 - 99</b>	<b>49 - 99</b>
<b>a</b>	<b>mm</b>	1160	1740	2320	2900	3480

**Corner installation, cascade module adaptor in a multi boiler system**

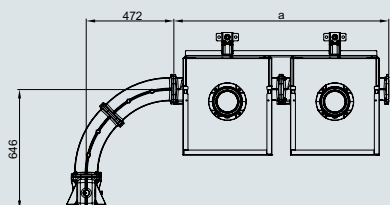

<b>Number of boilers</b>		<b>2</b>	<b>3</b>	<b>4</b>	<b>5</b>	<b>6</b>
<b>Rated heating output</b>	<b>kW</b>	<b>49 - 99</b>	<b>49 - 99</b>	<b>49 - 99</b>	<b>49 - 99</b>	<b>49 - 99</b>
<b>a</b>	<b>mm</b>	1160	1740	2320	2900	3480

Flue gas cascade - Series installation

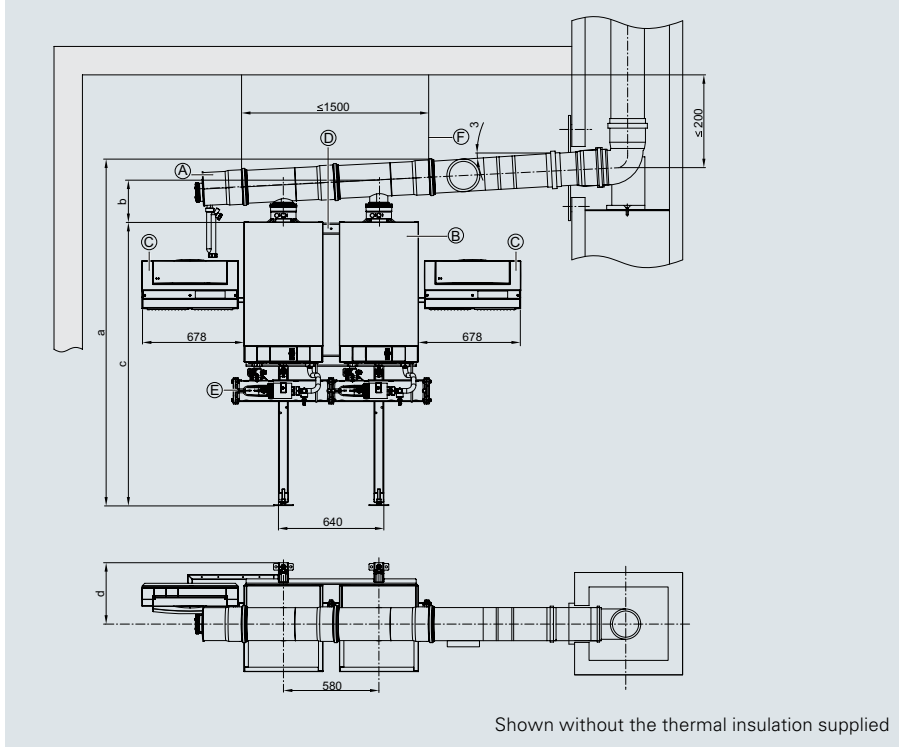

- Ⓐ Flue gas cascade
- Ⓑ Vitodens
- Ⓒ Vitotronic 300-K (can be fitted either to the left or the right)
- Ⓓ Mounting frame or pre-plumbing jig
- Ⓔ Hydraulic cascade
- Ⓕ Ceiling mounting for flue gas cascade

**Note**

Secure the flue gas cascade with suitable means. Suspension from the ceiling is recommended. Observe the max. distance between fixing points F.

Number of boilers		2 x 49 kW	2 x 80 kW	3 x 49 kW	3 x 80 kW	4 x 49 kW	4 x 80 kW	5 x 49 kW	5 x 80 kW	6 x 49 kW	6 x 80 kW
		2 x 60 kW	2 x 99 kW	3 x 60 kW	3 x 99 kW	4 x 60 kW	4 x 99 kW	5 x 60 kW	5 x 99 kW	6 x 60 kW	6 x 99 kW
a	mm	2111	2136	2141	2166	2196	2196	2251	2251	2281	2281
b	mm	231	256	261	286	316	316	371	371	401	401
c	mm	1750	1750	1750	1750	1750	1750	1750	1750	1750	1750
d	mm	291	373	291	373	291	373	291	373	291	373

**Note**

Height dimension "c" can be reduced by 150 mm in conjunction with a low loss header and by 300 mm in conjunction with a cascade module adaptor. In this case, the fixing profiles must be installed accordingly. For installation directly onto a wall, these dimensions should also be adhered to.

**Block formation**

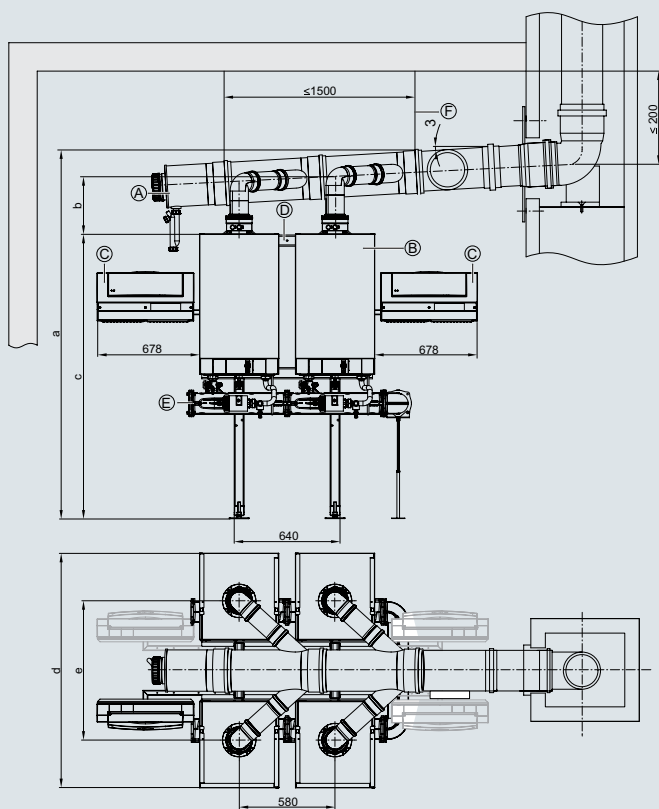

Shown without the thermal insulation supplied

- (A) Flue gas cascade
- (B) Vitodens
- (C) Vitotronic 300-K (can be fitted either to the left or the right)
- (D) Mounting frame or pre-plumbing jig
- (E) Hydraulic cascade
- (F) Ceiling mounting for flue gas cascade

**Note**

Secure the flue gas cascade with suitable means. Suspension from the ceiling is recommended. Observe the max. distance between fixing points F.

Boiler		(2 x 2) 49 kW	(2 x 2) 80 kW	(2 x 3) 49 kW	(2 x 3) 80 kW
		(2 x 2) 60 kW	(2 x 2) 99 kW	(2 x 3) 60 kW	(2 x 3) 99 kW
a	mm	2111	2136	2141	2166
b	mm	176	207	176	207
c	mm	1750	1750	1750	1750
d	mm	1350	1422	1350	1422
e	mm	680	843	680	843

**Note**

Height dimension "c" can be reduced by 150 mm in conjunction with a low loss header and by 300 mm in conjunction with a cascade module adaptor. In this case, the fixing profiles must be installed accordingly.

# High output gas condensing boilers

## Vitodens 200-W cascade system

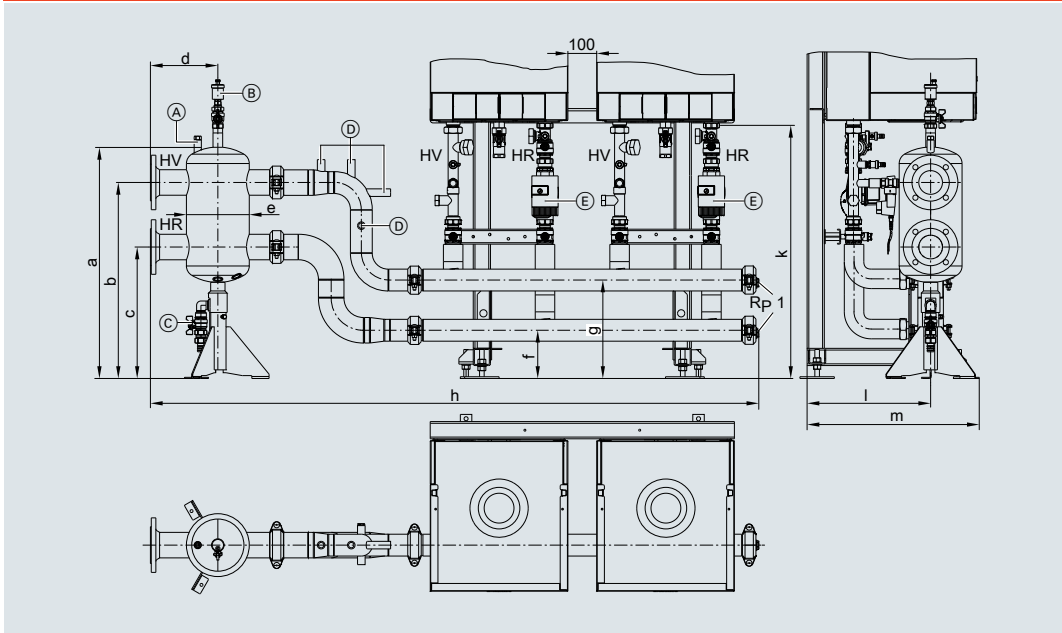

- Ⓐ Sensor well for flow temperature sensor
- Ⓑ Air vent valve
- Ⓒ Drain
- Ⓓ Connectors for safety equipment Rp ½
- Ⓔ Connection accessories with circulation pump
- HR Heating return
- HV Heating flow

### SERIES CASCADE

Boiler	Number	2 x 120 kW 2 x 150 kW	3 x 120 kW 3 x 150 kW	4 x 120 kW 4 x 150 kW	6 x 120 kW 6 x 150 kW
Heating circuit connection	PN6/DN	100	100	150	150
Boiler connection	G	2"	2"	2"	2"
Max. flow rate	m <sup>3</sup> /h	17.2	25.8	34.4	51.6
Dimensions	a mm	1218	1218	1218	1218
	b mm	972	972	972	972
	c mm	520	520	520	520
	d mm	380	380	380	380
	e mm	219	219	219	219
	f mm	168	168	168	168
	g mm	343	343	343	343
	h mm	2461	3159	3974	5372
k mm	1025	1025	1025	1025	
l mm	520	520	520	520	
m mm	710	710	710	710	

## Controls

Viessmann controls are easy to install, maintain and operate; and benefit from fault logging and diagnostic systems. They range from controlling a single boiler to a whole plant room and are available in constant temperature or weather compensated models. All Vitodens boilers will operate with Viessmann and third party external controls.

		<b>VITOTRONIC 100</b> (constant temperature)	<b>VITOTRONIC 200</b> (weather compensation)
<b>ROOM TEMPERATURE CONTROL UNITS</b>			
<b>VITOTROL 100</b> (type UTA) <ul style="list-style-type: none"> <li>Room thermostat with switching output</li> <li>Analogue time switch &amp; day program</li> </ul>		7170149	-
<b>VITOTROL 100</b> (type UTDB) <ul style="list-style-type: none"> <li>Digital room temperature controller with switching output</li> <li>Individual day and seven-day programs</li> <li>Independent of main power supply</li> </ul>		Z007691	-
<b>VITOTROL 100</b> (type UTDB-RF) <ul style="list-style-type: none"> <li>Room temperature controller with integral wireless transmitter and separate receiver</li> <li>With switching output (two point output)</li> <li>With battery operation 3 V, receiver with mains voltage</li> </ul>		Z007692	-
<b>REMOTE CONTROL UNITS</b>			
<b>VITOTROL 200A</b> KM BUS For setting one heating circuit <ul style="list-style-type: none"> <li>Set room temperature and operating program</li> <li>Display to show outside temperature, room temperature and operating conditions</li> <li>Room temperature sensor for room temperature hook-up</li> </ul>		-	Z008341
<b>VITOTROL 300A</b> KM BUS For setting one, two or three heating circuits <ul style="list-style-type: none"> <li>Set room temperature and reduced set room temperature, DHW temperature</li> <li>Time program for the heating circuits, DHW cylinder and DHW circulation pump</li> </ul>		-	Z008342
<b>WIRELESS CONTROL UNITS</b>			
<b>VITOTROL 100</b> Monitor and control your heating system from your mobile or tablet <ul style="list-style-type: none"> <li>Easy set up – all it takes is one message</li> <li>No landline required</li> <li>Easy to retrofit</li> </ul>		-	Z011224
<b>VITOTROL 200 RF</b> Remote control with integral wireless transmitter. For setting one heating circuit <ul style="list-style-type: none"> <li>Set room temperature and operating program</li> <li>Display to show outside temperature, room temperature and operating conditions</li> </ul>		-	Z011219
<b>VITOTROL 300 RF</b> Remote control with integral wireless transmitter. For setting one, two or three heating circuits <ul style="list-style-type: none"> <li>Set room temperature and reduced set room temperature, DHW temperature</li> <li>Time program for the heating circuits, DHW cylinder and DHW circulation pump</li> <li>Integral room temperature sensor</li> </ul>		With table-top dock	Z011410
		With wall mounting bracket	Z011412
<b>Wireless outdoor temperature sensor</b> Wireless, light-activated outside temperature sensor with integral wireless transmitter for operation with the wireless base station and the control unit.			7455213
<b>Wireless base station</b> Required with wireless units Vitotrol 200 RF and Vitotrol 300 RF <ul style="list-style-type: none"> <li>Vitotrol 200 RF wireless remote control</li> <li>Vitotrol 300 RF wireless remote control</li> <li>Wireless outside temperature sensor</li> </ul>			Z011413
<b>Wireless repeater</b> Mains operated repeater to increase the wireless range and for use in areas where wireless communication is difficult. <ul style="list-style-type: none"> <li>For preventing over-diagonal angle of penetration of the radio signals through iron reinforced concrete ceilings and/or multiple walls</li> <li>For circumventing large metallic objects situated between the wireless components</li> </ul> No more than 1 wireless repeater per Vitotronic.			7456538

# High output gas condensing boilers

## HEATING CIRCUIT AND DHW CYLINDER

Only for single boiler 49 to 150 kW

	<b>Part number</b>
<p><b>Heating circuit connection set without circulation pump</b></p> <p>For the Vitodens 200-W with 49 and 60 kW. For combination with external system separation or heating water buffer cylinder.</p> <ul style="list-style-type: none"> <li>■ Tee with ball valve</li> <li>■ BDF valve</li> <li>■ Safety valve 4 bar (0.4 MPa)</li> <li>■ Straight-through gas valve with integral, thermally activated safety shut-off valve</li> </ul>	7245738
<p><b>Connection set with variable speed high efficiency circulation pump - comprising:</b></p> <ul style="list-style-type: none"> <li>■ Tee with ball valve / Check valve / Fill and drain valve / Built-in non return valve</li> <li>■ Thermal insulation</li> <li>■ Straight-through gas valve with integral thermally activated safety shut off valve</li> <li>■ Safety valve</li> <li>■ Circulation pump (high efficiency)</li> </ul>	7501311
<p><b>Connection set for DHW cylinder - comprising:</b></p> <ul style="list-style-type: none"> <li>■ Ball valve / Check valve / Built-in non return valve</li> <li>■ Cylinder primary pump</li> <li>■ Cylinder temperature sensor (3.75m long)</li> <li>■ H1 internal extension</li> </ul> <p>For integration into thermal insulation of connection set for heating circuit with circulation pump</p>	ZK00657
<p><b>Connection set for heating circuit with high efficiency circulation pump and low loss header</b></p> <p>For the Vitodens 200-W with 49 and 60 kW.</p> <ul style="list-style-type: none"> <li>■ Safety valve 4 bar (0.4 MPa)</li> <li>■ Variable speed high efficiency circulation pump</li> <li>■ Straight-through gas valve with integral, thermally activated safety shut-off valve</li> <li>■ Low loss header with immersion temperature sensor</li> <li>■ Thermal insulation</li> </ul> <p><i>Wall mounting bracket or mounting frame must also be ordered.</i></p>	ZK03663
<p><b>DHW cylinder connection set</b></p> <p>2 x Tee G 1½</p>	ZK03669
<p><b>Connection set with variable speed high efficiency circulation pump - comprising:</b></p> <ul style="list-style-type: none"> <li>■ Tee with ball valve / Check valve / BDF valve / Safety valve</li> <li>■ Straight-through gas valve with integral thermally activated safety shut off valve</li> <li>■ Ball valve (2 pce)</li> <li>■ Thermal insulation</li> <li>■ Circulation pump (high efficiency)</li> </ul>	7501318
<p><b>Connection set for DHW cylinder - comprising:</b></p> <ul style="list-style-type: none"> <li>■ Cylinder flow and return</li> <li>■ Fittings G 1.25"</li> <li>■ Cylinder temperature sensor</li> <li>■ H1 internal extension</li> </ul>	7348934
<p><b>Connection set for heating circuit with high efficiency circulation pump and low loss header</b></p> <p>For the Vitodens 200-W with 80 and 99 kW.</p> <ul style="list-style-type: none"> <li>■ Safety valve 4 bar (0.4 MPa)</li> <li>■ Variable speed high efficiency circulation pump</li> <li>■ Straight-through gas valve with integral, thermally activated safety shut-off valve</li> <li>■ Low loss header with immersion temperature sensor</li> <li>■ Thermal insulation</li> </ul> <p><i>Wall mounting bracket or mounting frame must also be ordered.</i></p>	ZK03831
<p><b>DHW cylinder connection set</b></p> <p>2 x Tee G 1½</p>	ZK03669

**Heating circuit connection set with variable speed high efficiency circulation pump - comprising:**

7501325

- Circulation pump
- 2 ball valves with adaptors Ø 54 mm (locking ring fitting)
- Tee with ball valve
- Non-return valve
- Boiler drain & fill valve
- Safety valve
- Gas shut-off valve with integral thermally activated safety shut-off valve
- Thermal insulation
- Connection G1 for expansion vessel

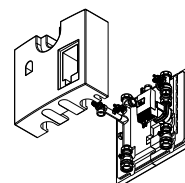

**Connection set for DHW cylinder - comprising:**

7501325

- Connecting lines for flow and return
- Fittings
- Cylinder temperature sensor

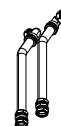

**Connection set with low loss header – comprising:**

ZK03664

- For the Vitodens 200-W with 120 and 150 kW.
- Boiler drain & fill valve
  - Safety valve 6 bar (0.6 MPa)
  - Variable speed high efficiency circulation pump
  - Straight-through gas valve with integral, thermally activated safety shut-off valve Rp 1
  - Low loss header with immersion temperature sensor
  - Quick-action air vent valve
  - Connection G 1 (male thread) for diaphragm expansion vessel
  - Thermal insulation

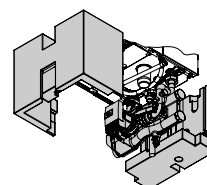

**Connection set for DHW cylinder for 120 & 150 kW – comprising:**

ZK03670

- Connecting lines for flow and return
- Fittings
- Cylinder temperature sensor

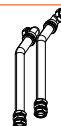

**Mounting frame for 49 to 150 kW**

For self-supporting boiler installation in a room.  
With adjustable feet for levelling and securing to the floor.

ZK03678

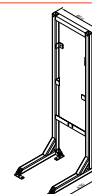

**Wall hanging bracket**

ZK03677

**Dual sensor well for combining Vitodens 200-W with a heat pump:**

For installation in the heating circuit connection set, for positioning a second flow temperature sensor.

ZK03672



**ACCESSORIES FOR CASCADE KITS**

**Hydraulic adapter cascade module**

DN100



**Part number** ZK02628

**Transition flange**

DN80 to R2



**Part number** ZK03678

**Transition flange**

DN100 to R2



**Part number** ZK02629

**Pipe elbows set**

90°



**Part number** ZK02630

**CONDENSATE COLLECTOR PIPES**

**2 boiler cascade**

**Part number** ZK02631



**3 boiler cascade**

**Part number** ZK02632



**4 boiler cascade**

**Part number** ZK02633



**5 boiler cascade**

**Part number** ZK02634



**6 boiler cascade**

**Part number** ZK02635



## Heating circulation pumps

Heating pumps are, due to their high annual operating hours, among the largest power-consuming appliances in buildings.

After the compressor, the circulation pump is the biggest consumer of electrical power and is therefore the major efficiency factor for the entire application. Automatic pump performance control helps drastically to reduce power consumption in heating pumps. Compared to standard pumps, high-efficiency pumps can even save up to 80% electricity costs.

From 2013 onwards, the European Eco-Design directive (EC ordinance 641/2009) for 'energy related products' will impose increasingly stricter requirements for the energy efficiency of pumps. Due to the ErP directive, only extremely power saving high efficiency pumps may be used.

An energy class A pump requires on average only around 33% of the electrical energy consumed by a class D pump. Viessmann high efficiency pumps use the same highly efficient motor technology with energy efficiency class A.

These pumps are included in the Vitodens 200-W range, which not only produces environmentally friendly results, but provides lower electricity bills for the building owner. This can be up to £105 for a single boiler, per year.



## Divicons

### ROOM TEMPERATURE CONTROL UNITS

#### Divicon heating circuit distributor with mixer

- Heating circuit pump (variable speed high efficiency circulation pump, compliant with Energy Label A), fully wired
- Check valve
- 2 ball valves with thermometer.
- Thermal insulation
- Extension kit for one heating circuit with mixer, including connecting cable (3.5 m long)



DN20 - ¾"

DN25 - 1"

DN32 - 1¼"

#### Fully fitted Divicon heating circuit distributor

With mixer-3 and extension kit  
With mixer PCB and mixer motor  
With circulation pump Wilo Stratos Para 25/1-7

7521285

7521286

7369520

Cable kit (with plugs 40 and 145)

To replace the connecting cable supplied in the standard delivery for linking the two mixer PCBs, in the case of 2 heating circuits with mixer.

7424960

7424960

7424960

#### Divicon heating circuit distributor without mixer

- Heating circuit pump (variable speed high efficiency circulation pump, compliant with Energy Label A), fully wired
- Check valve
- 2 ball valves with thermometer
- Thermal insulation



7521287

7521288

7369522

#### Fully fitted Divicon heating circuit distributor

Without mixer circulation pump Wilo Stratos Para 25/1-7

#### Note

Actuator for mixer to be ordered separately – see price guide

# Divicons

Vitodens 200-W divicons are part of a local circuit pump assembly, with or without a mixer. One or more may be used to control parts of a larger system with weather compensated control.

## HEATING CIRCUIT – MODULAR-DIVICON

	<b>Part number</b>
<b>Manifold</b> for 2 Modular-divicon – wall mounted with thermal insulation (black) (wall mounting to be ordered separately) 	DN20 - ¾" & DN25 - 1" - 7460638 DN32 - 1¼" - 7466337 (also order 7465439)
<b>Manifold</b> for 3 Modular-divicon – wall mounted with thermal insulation (black) (wall mounting to be ordered separately) 	DN20 - ¾" & DN25 - 1" - 7460643 DN32 - 1¼" - 7466340 (also order 7465439)
<b>Low loss header</b> Volume flow up to 4.5m <sup>3</sup> /h connection to the manifolds with thermal insulation (black) with integral sensor well 50mm long	7460649
Volume flow up to 7.5 m <sup>3</sup> /h with thermal insulation with integral sensor with integrated deaerator	7460648
<b>Immersion temperature sensor</b> for measuring the temperature in the low loss header for Vitodens 200-W with 49 and 60 kW (for multi boiler systems with Vitotronic 300-K and Vitodens 200-W with 80 and 99 kW in the heating circuit set connection set standard delivery)	7179488

## DHW HEATING

Only for single boiler

	<b>Part number</b>
<b>Cylinder temperature sensor</b> part of the standard delivery with part no Z007620 and 7348934	7179114
<b>Sensor well (for cylinder temperature sensor)</b> part of the standard delivery for Viessmann Vitocell 300 cylinders	7819693

**GAS BOILER, TYPE B AND C, CATEGORY II<sub>2N3P</sub>**

Rated heating output range

49 and 60 kW: Details to EN 15502-1.

80 to 150 kW: Details to EN 15417.

**Gas condensing boiler**

		<b>12.0-49.0</b>	<b>12.0-60.0</b>	<b>20.0-80.0</b>	<b>20.0-99.0</b>	<b>32.0-120.0</b>	<b>32.0-150.0</b>
<b>T<sub>F</sub>/T<sub>R</sub> = 50/30 °C when operating with natural gas</b>	<b>kW</b>	<b>12.0-49.0</b>	<b>12.0-60.0</b>	<b>20.0-80.0</b>	<b>20.0-99.0</b>	<b>32.0-120.0</b>	<b>32.0-150.0</b>
<b>T<sub>F</sub>/T<sub>R</sub> = 80/60 °C when operating with natural gas</b>	<b>kW</b>	<b>10.9-45.0</b>	<b>10.9-55.2</b>	<b>18.2-74.1</b>	<b>18.2-90.9</b>	<b>29.1-110.9</b>	<b>29.0-136.0</b>
<b>T<sub>F</sub>/T<sub>R</sub> = 50/30 °C when operating with LPG P</b>	kW	17.0-49.0	17.0-60.0	30.00-80.0	30.0-99.0	32.0-120.0	32.0-150.0
<b>T<sub>F</sub>/T<sub>R</sub> = 80/60 °C when operating with LPG P</b>	kW	15.5-45.0	15.5-55.2	27.3-74.1	27.3-90.9	29.1-110.9	29.0-136.0
<b>Rated heat input when operating with natural gas</b>	kW	11.2-45.7	11.2-56.2	18.8-75.0	18.8-92.9	30.0-113.3	30.0-142.0
<b>Rated heat input when operating with LPG P</b>	kW	16.1-45.7	16.1-56.2	28.1-75.0	28.1-92.9	30.3-113.3	30.0-142.0
<b>Type</b>		B2HA	B2HA	B2HA	B2HA	B2HA	B2HA
<b>Product ID</b>		CE-0085CN0050					
<b>IP rating</b>		IP X4 to EN 60529					
<b>Gas supply pressure</b>							
Natural gas	mbar	17	17	17	17	17.4	17.4
LPG	mbar	32	32	32	32	32	32
<b>Max. permissible gas supply pressure*1</b>							
Natural gas	mbar	25.0	25.0	25.0	25.0	25.0	25.0
LPG	mbar	57.5	57.5	42.5	42.5	57.5	57.5
<b>Sound power level</b>							
(Details to EN ISO 15036-1)							
At partial load	dB(A)	39	39	39	39	40	40
At rated heating output	dB(A)	58	67	56	59	54	60
<b>Power consumption (delivered condition)</b>	W	48	69	45	66	73	88
<b>Weight</b>	kg	65	65	83	83	130	130
<b>Heat exchanger capacity</b>	l	7.0	7.0	12.8	12.8	15.0	15.0
<b>Max. flow temperature</b>	°C	81	81	81	81	85	85
<b>Max. flow rate</b>	l/h	3500	3500	5700	5700	7165	8600
Limit for the use of hydraulic separation							
<b>Nominal circulation water volume at T<sub>F</sub>/T<sub>R</sub> = 80/60 °C</b>	l/h	1748	2336	3118	3909	4900	5850
<b>Permiss. operating pressure</b>	bar	4	4	4	4	6	6
	MPa	0.4	0.4	0.4	0.4	0.6	0.6
<b>Dimensions</b>							
Length	mm	380	380	530	530	690	690
Width	mm	480	480	480	480	600	600
Height	mm	850	850	850	850	900	900
<b>Gas connection</b>	R	¾	¾	1	1	1	1
<b>Connection values</b>							
Relative to max. load							
With gas							
Natural gas E	m <sup>3</sup> /h	4.47	5.95	7.94	9.93	12.49	15.03
Natural gas LL	m <sup>3</sup> /h	5.19	6.91	9.23	11.54	14.51	17.47
LPG	kg/h	3.30	4.39	5.86	7.33	9.23	11.10

**GAS BOILER, TYPE B AND C, CATEGORY II<sub>2N3P</sub>**

Rated heating output range

49 and 60 kW: Details to EN 15502-1.

80 to 150 kW: Details to EN 15417.

**Gas condensing boiler**

		<b>12.0-49.0</b>	<b>12.0-60.0</b>	<b>20.0-80.0</b>	<b>20.0-99.0</b>	<b>32.0-120.0</b>	<b>32.0-150.0</b>
<b>T<sub>F</sub>/T<sub>R</sub> = 50/30 °C when operating with natural gas</b>	<b>kW</b>	<b>12.0-49.0</b>	<b>12.0-60.0</b>	<b>20.0-80.0</b>	<b>20.0-99.0</b>	<b>32.0-120.0</b>	<b>32.0-150.0</b>
<b>T<sub>F</sub>/T<sub>R</sub> = 80/60 °C when operating with natural gas</b>	<b>kW</b>	<b>10.9-45.0</b>	<b>10.9-55.2</b>	<b>18.2-74.1</b>	<b>18.2-90.9</b>	<b>29.1-110.9</b>	<b>29.0-136.0</b>
<b>Flue gas parameters*2</b>							
Flue gas category to G 635/G 636		G <sub>52</sub> /G <sub>51</sub>	G <sub>52</sub> /G <sub>51</sub>	G <sub>52</sub> /G <sub>51</sub>	G <sub>52</sub> /G <sub>51</sub>	G <sub>52</sub> /G <sub>51</sub>	G <sub>52</sub> /G <sub>51</sub>
Temperature (at a return temperature of 30 °C)							
- At rated heating output	°C	62	66	46	57	51	60
- At partial load	°C	39	39	37	37	39	39
Temperature (at a return temperature of 60 °C)	°C	75	80	68	72	70	74
Mass flow rate							
Natural gas							
- At rated heating output	kg/h	78	104	139	174	210	253
- At partial load	kg/h	30	30	52	52	53	53
LPG							
- At rated heating output	kg/h	74	99	132	165	231	278
- At partial load	kg/h	28	28	49	49	59	59
Available draught	Pa	250	250	250	250	250	250
	bar	2.5	2.5	2.5	2.5	2.5	2.5
<b>Max. amount of condensate</b>							
To DWA-A 251	l/h	6.3	8.41	12	14.0	17.5	21.0
<b>Condensate connection (hose nozzle)</b>	Ømm	20-24	20-24	20-24	20-24	20-24	20-24
<b>Flue gas connection</b>	Ømm	80	80	100	100	100	100
<b>Ventilation air connection</b>	Ømm	125	125	150	150	150	150
<b>Standard seasonal efficiency [to DIN] at</b>							
T <sub>F</sub> /T <sub>R</sub> = 40/30 °C		%Up to 98 (H <sub>2</sub> ) [gross cv] / 109 (H <sub>2</sub> ) [net cv]					
<b>Energy efficiency class</b>	A	A—					

\*1 If the gas supply pressure is higher than the maximum permissible value, install a separate gas pressure governor upstream of the system.

\*2 Calculation values for sizing the flue system to EN 13384. Flue gas temperatures as actual gross values at 20 °C combustion air temperature.

The flue gas temperature at a return temperature of 30 °C is significant for the sizing of the flue system.

The flue gas temperature at a return temperature of 60 °C is used to determine the application range of flue pipes with maximum permissible operating temperatures.



- Ⓐ Inox-Radial heat exchanger made from stainless steel – for high operational reliability and a long service life. High heating output on a very small footprint
- Ⓑ Modulating Matrix cylinder burner for extremely clean combustion and quiet operation
- Ⓒ Variable speed combustion fan for quiet and economical operation
- Ⓓ Gas and water connections
- Ⓔ Digital boiler control unit

Vitodens 200-W, 49 to 60 kW with low loss header

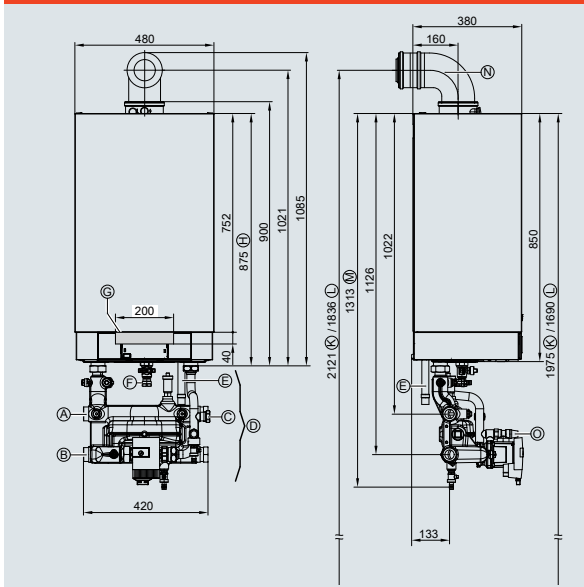

Vitodens 200-W, 49 to 60 kW without low loss header

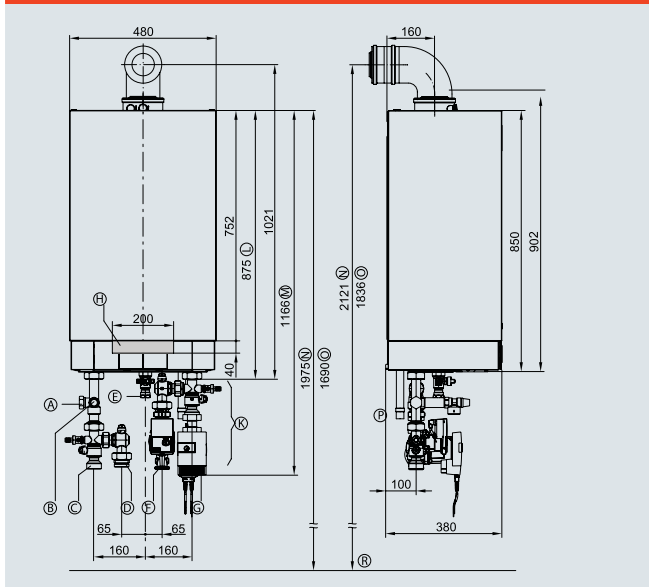

- Ⓐ Expansion vessel connection G 1
- Ⓑ Safety valve
- Ⓒ Heating flow G 1½
- Ⓓ Cylinder flow G 1½
- Ⓔ Gas connection R ¾
- Ⓕ Cylinder return G 1½
- Ⓖ Heating return G 1½
- Ⓗ Cable entry area at the back
- Ⓚ Connection sets (accessories)  
Shown without thermal insulation (standard delivery)
- Ⓛ Without connection sets
- Ⓜ With connection sets
- Ⓝ Recommended dimension for a single boiler system
- Ⓞ Recommended dimension for a multi boiler system
- Ⓟ Condensate drain
- Ⓡ Top edge finished floor

**Note**

The heating circuit connection set must be ordered separately. Lay all required supply cables on site and route them into the boiler in the specified area.

**Variable speed high efficiency circulation pump in the heating circuit connection set (accessories)**

The highly efficient circulation pump uses significantly less power compared to conventional pumps. Matching the pump rate of the circulation pump to the individual system conditions reduces the power consumption of the heating system.

**Circulation pump VI Para 25/1-11**

Rated voltage	V ~	230
Power consumption	W Max.	140
	W Min.	8

Vitodens 200-W, 80 to 99 kW

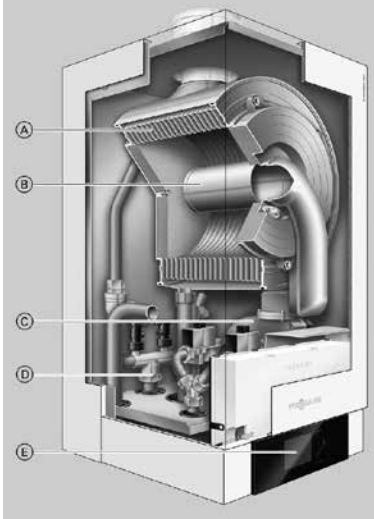

- Ⓐ Inox-Radial heat exchanger made from stainless steel – for high operational reliability and a long service life. High heating output on a very small footprint
- Ⓑ Modulating Matrix cylinder burner for extremely clean combustion and quiet operation
- Ⓒ Variable speed combustion fan for quiet and economical operation
- Ⓓ Gas and water connections
- Ⓔ Digital boiler control unit

Vitodens 200-W, 80 to 99 kW with low loss header

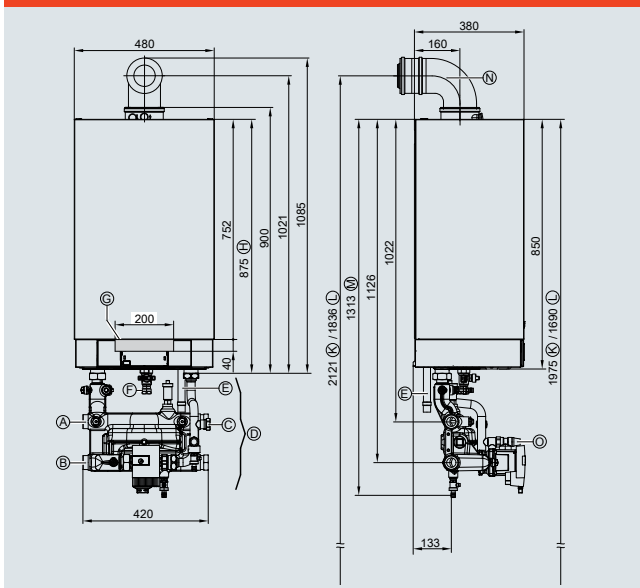

Vitodens 200-W, 80 to 99 kW without low loss header

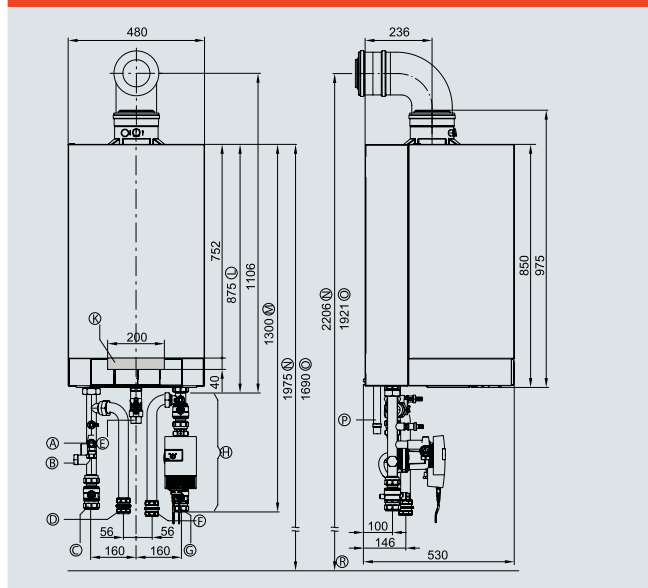

- Ⓐ Safety valve
- Ⓑ Expansion vessel connection G 1
- Ⓒ Boiler flow Ø 42 mm
- Ⓓ Cylinder flow Ø 35 mm
- Ⓔ Gas connection R 1
- Ⓕ Cylinder return Ø 35 mm
- Ⓖ Boiler return Ø 42 mm
- Ⓗ Connection sets (accessories)  
Shown without thermal insulation (standard delivery)
- Ⓚ Cable entry area at the back
- Ⓛ Without connection set (accessories)
- Ⓜ With connection set (accessories)
- Ⓝ Recommended dimension (single boiler system)
- Ⓞ Recommended dimension (multi boiler system)
- Ⓟ Condensate drain
- Ⓡ Top edge finished floor

**Note**

The heating circuit connection set must be ordered separately. Lay all required supply cables on site and route them into the boiler in the specified area.

**Variable speed high efficiency circulation pump in the heating circuit connection set (accessories)**

The highly efficient circulation pump uses significantly less power compared to conventional pumps. Matching the pump rate of the circulation pump to the individual system conditions reduces the power consumption of the heating system.

**Circulation pump VI Para 25/1-12**

Rated voltage	V ~	230
Power consumption	W Max.	310
	W Min.	16

Vitodens 200-W, 120 to 150 kW

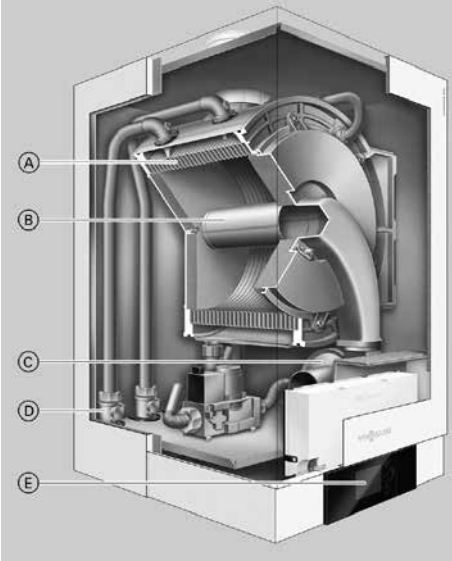

- Ⓐ Inox-Radial heat exchanger made from stainless steel – for high operational reliability and a long service life. High heating output on a very small footprint
- Ⓑ Modulating MatriX cylinder burner for extremely clean combustion and quiet operation
- Ⓒ Variable speed combustion fan for quiet and economical operation
- Ⓓ Gas and water connections
- Ⓔ Digital boiler control unit

Vitodens 200-W, 120 to 150 kW with low loss header

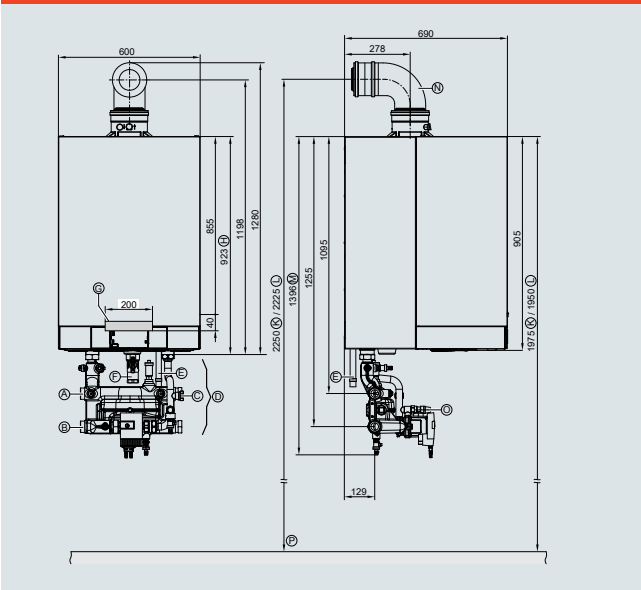

Vitodens 200-W, 120 to 150 kW without low loss header

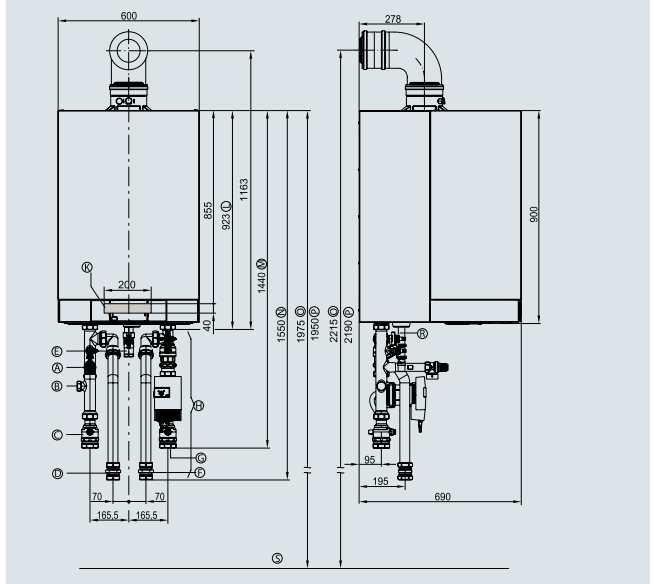

- Ⓐ Safety valve
- Ⓑ Expansion vessel connection G 1
- Ⓒ Boiler flow Ø 54 mm
- Ⓓ Cylinder flow Ø 42
- Ⓔ Gas connection R 1
- Ⓕ Cylinder return Ø 42 mm
- Ⓖ Boiler return Ø 54 mm
- Ⓗ Connection sets (accessories)  
Shown without thermal insulation (standard delivery)
- Ⓚ Cable entry area at the back
- Ⓛ Without connection set (accessories)
- Ⓜ With heating circuit connection set (accessories)
- Ⓝ With DHW cylinder connection set (accessories)
- Ⓞ Recommended dimension (single boiler system without mounting frame)
- Ⓟ Recommended dimension (multi boiler system or single boiler system with mounting frame)
- Ⓡ Condensate drain
- Ⓢ Top edge finished floor

**Note**

The heating circuit connection set must be ordered separately. Lay all required supply cables on site and route them into the boiler in the specified area.

**Variable speed high efficiency circulation pump in the heating circuit connection set (accessories)**

The highly efficient circulation pump uses significantly less power compared to conventional pumps. Matching the pump rate of the circulation pump to the individual system conditions reduces the power consumption of the heating system.

**Circulation pump VI Para 30/1-12**

Rated voltage	V ~	230
Power consumption	W Max.	310
	W Min.	16

Viessmann Limited  
Hortonwood 30, Telford  
Shropshire, TF1 7YP  
Tel: 01952 675000  
Fax: 01952 675040  
**[www.viessmann.co.uk](http://www.viessmann.co.uk)**

Your trade partner: