

virtu~~fit~~fit

Elite FDR 2.5i Semi-Pro Crosstrainer

User manual

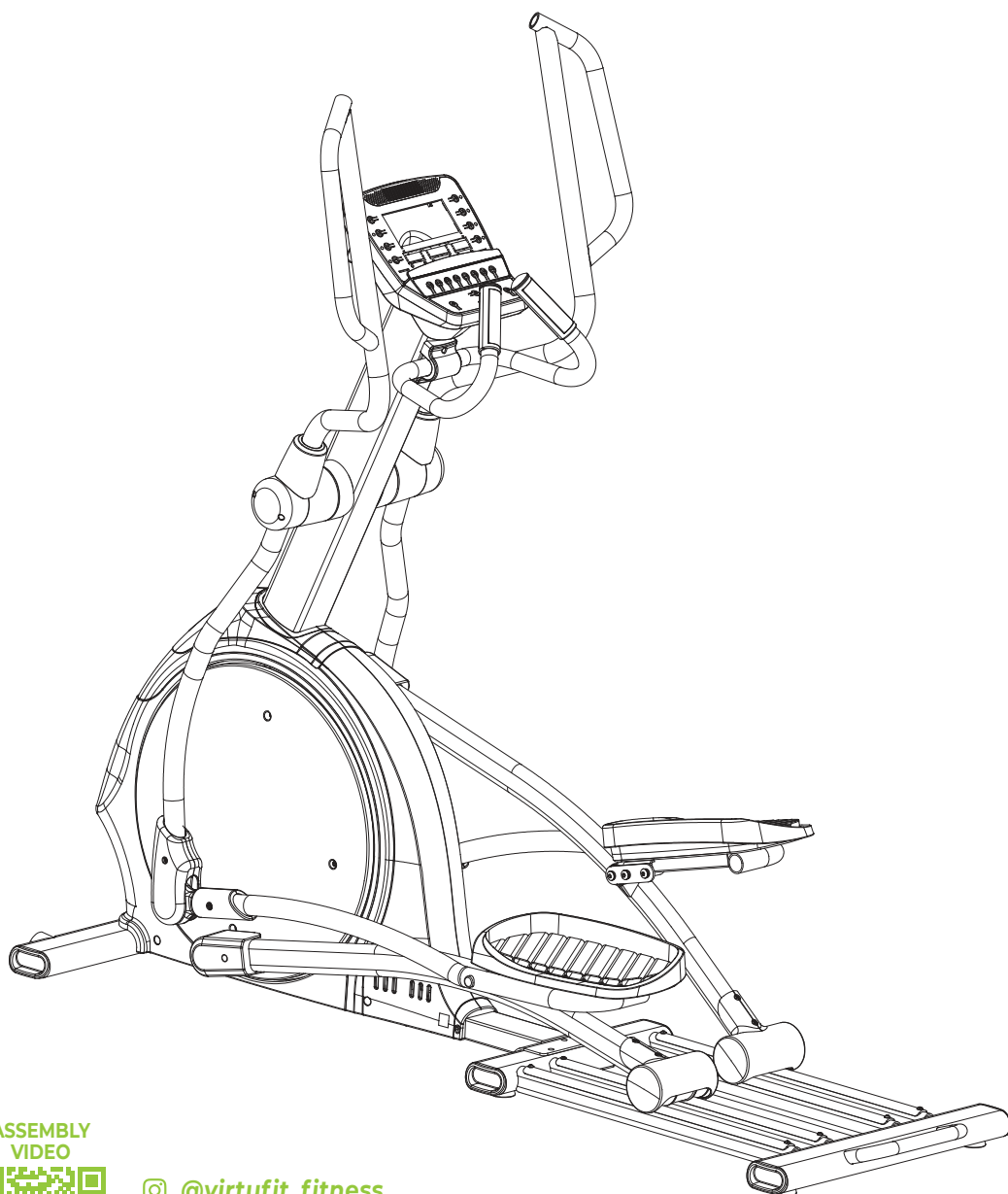

HOW TO
RECYCLE



ASSEMBLY
VIDEO



Instagram icon [@virtufit_fitness](#)

YouTube icon [VirtuFit](#)

Globe icon www.virtufit.com

SAFETY INSTRUCTIONS	3 - 4
CHECKLIST	5 - 6
ASSEMBLY INSTRUCTIONS	7 - 10
ADJUSTMENTS GUIDE	11
MOVING	12
MAINTENANCE	13
TROUBLE SHOOTING	14
CONTROL PANEL	15 - 22
EXPLODED DRAWING	23 - 24
PARTS LIST	25 - 26
APP INSTRUCTIONS	27
TRAINING INSTRUCTIONS	28

WARNING:

Before beginning any exercise program consult your physician. This is especially important for people who are over 35 years old or who have pre-existing health problems. Read all instructions before using any fitness equipment. Do not operate this device without properly fitted guards, as the moving parts can present a risk of serious injury if exposed.

ATTENTION

- It is important to read this entire manual before assembling and using the device. Safe and effective use can only be achieved if the device is assembled, maintained and used properly. It is your responsibility to ensure that all users of the device are informed of all warnings and precautions.
- Before starting any exercise program, you should consult your doctor to determine if you have any medical or physical conditions that could put your health and safety at risk, or prevent you from using the device properly. Your doctor's advice is essential if you are taking medication that affects your heart rate, blood pressure or cholesterol level.
- Be aware of your body's signals. Incorrect or excessive exercise can damage your health. Stop exercising if you experience any of the following symptoms: pain, tightness in your chest, irregular heartbeat, extreme shortness of breath, lightheadedness, dizziness or feelings of nausea. If you do experience any of these conditions you should consult your doctor before continuing with your exercise program.
- Keep children and pets away from the device. The device is designed for adult use only.
- Use the device on a solid, flat level surface with a protective cover for your floor or carpet. To ensure safety, the device should have at least 0.5 metres of free space all around it.
- Before using the device, check that the nuts and bolts are securely tightened.
- The safety of the device can only be maintained if it is regularly examined for damage and/or wear and tear.

- Always use the device as indicated. If you find any defective components while assembling or checking the device, or if you hear any unusual noises coming from the device during use, stop immediately. Do not use the device until the problem has been rectified.
- Wear suitable clothing while using the device. Avoid wearing loose clothing that may get caught in the device or that may restrict or prevent movement.
- The max user weight is 165 KGS. Braking ability is independent of speed.
- The device is not suitable for therapeutic use.
- Care must be taken when lifting or moving the device so as not to injure your back. Always use proper lifting techniques and/or seek assistance if necessary.
- Please keep the space at least 1 to 2 meter at the end of base frame to escape any accidents!
- Place the device on a clean and flat surface. Do not place the device on a thick carpet.
- The device is for indoor use and not for outdoor use to prevent damage. Keep the storage location dry, clean and flat. It is forbidden to use the device for purposes other than training.
- Only use the machine in an environment with an ambient temperature between 10 °C and 35 °C. Only store the device at an ambient temperature between 5 °C and 45 °C.

Warranty claim is excluded if the cause of the defect is the result of:

- Maintenance assembly and repair work not carried out by an official dealer.
- In the event of improper use, neglect and / or poor maintenance.
- Failure to maintain the device in accordance with the manufacturer's instructions (see the enclosed manual).

TOOLKIT

When you open the carton, and you will find the below parts in the carton.

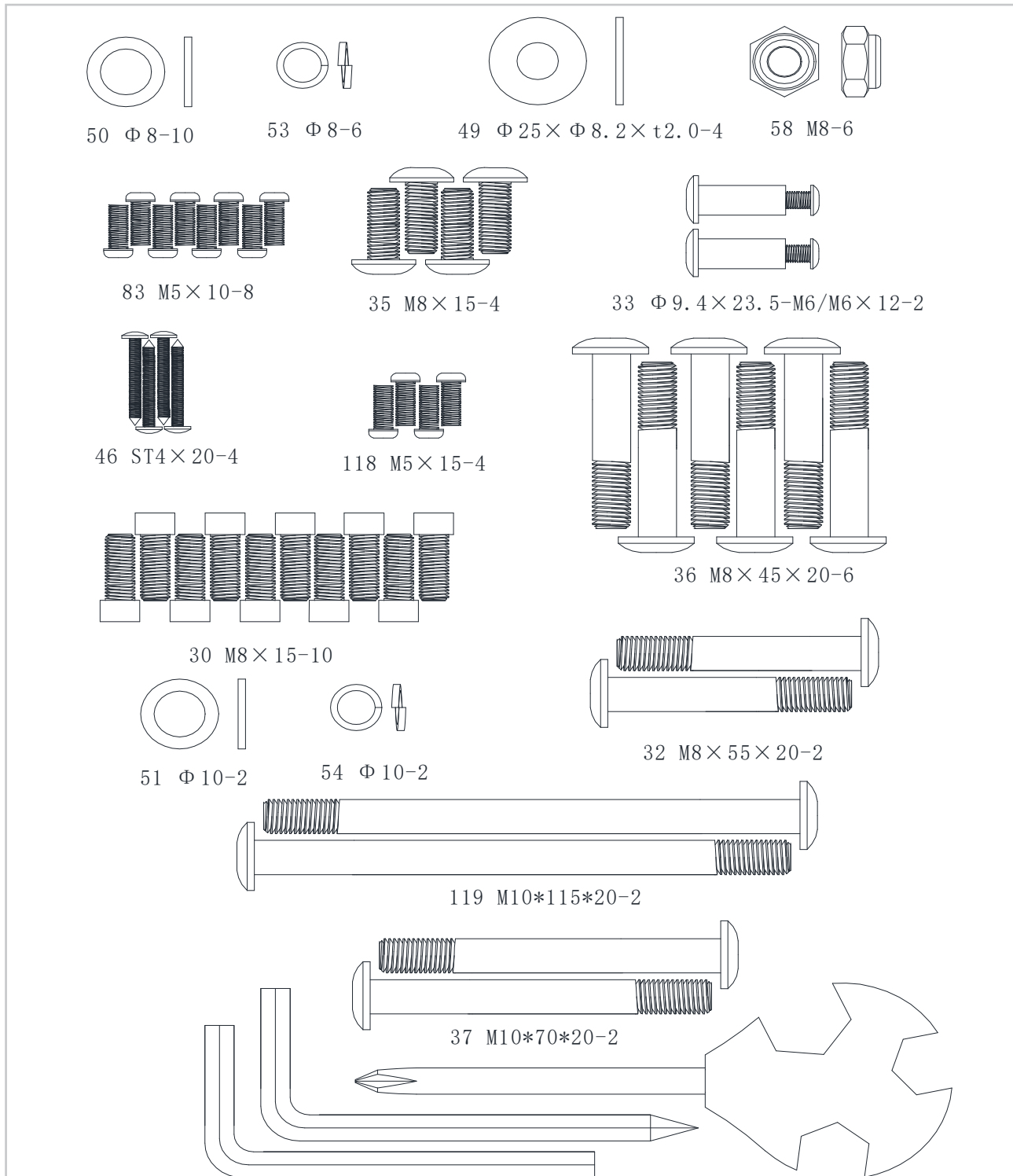

Missing parts: If you think you are missing certain parts in your package, carefully check the styrofoam and the device. Some parts (bolts, screws, etc.) are already attached to/in the device.

Error message: Ensure that all cables are carefully attached. The aluminum legs are very sensitive and must remain straight. Do you receive an error message after mounting your device? Then you have to straighten these aluminum legs again, this may cause the error message to disappear.

Socket screws: The device contains socket screws, make sure that the allen key is firmly in the bolt before you apply force to the key. In this way you prevent the head of the socket head screw from being rotated.

NOTE! *The transport wheels must be mounted on the front of the appliance.*

STEP 1

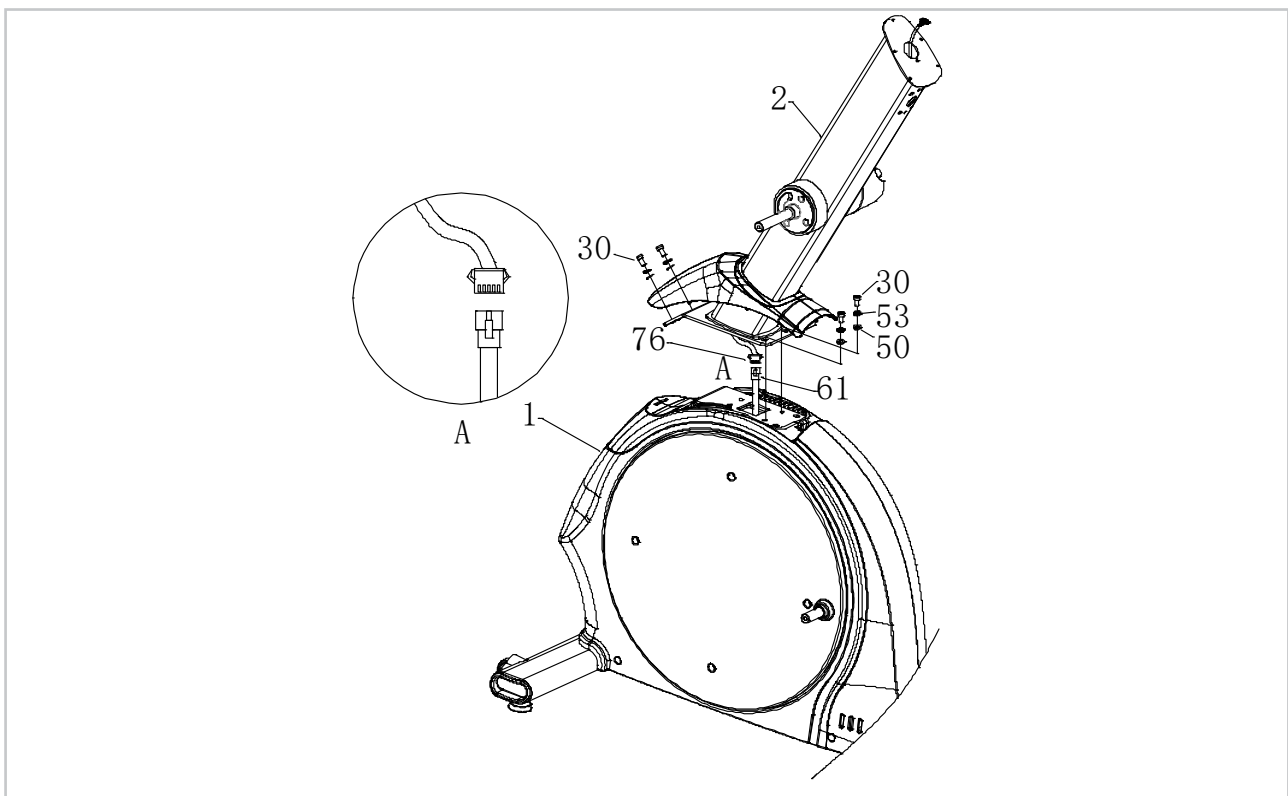

- Connect the motor communication wire (61) with Upright post communication wire (76).
- Attach the upright post (2) to the main frame (1) with Allen cylinder head full thread screw (30), Flat washer (50) and Spring washer (53).

STEP 2

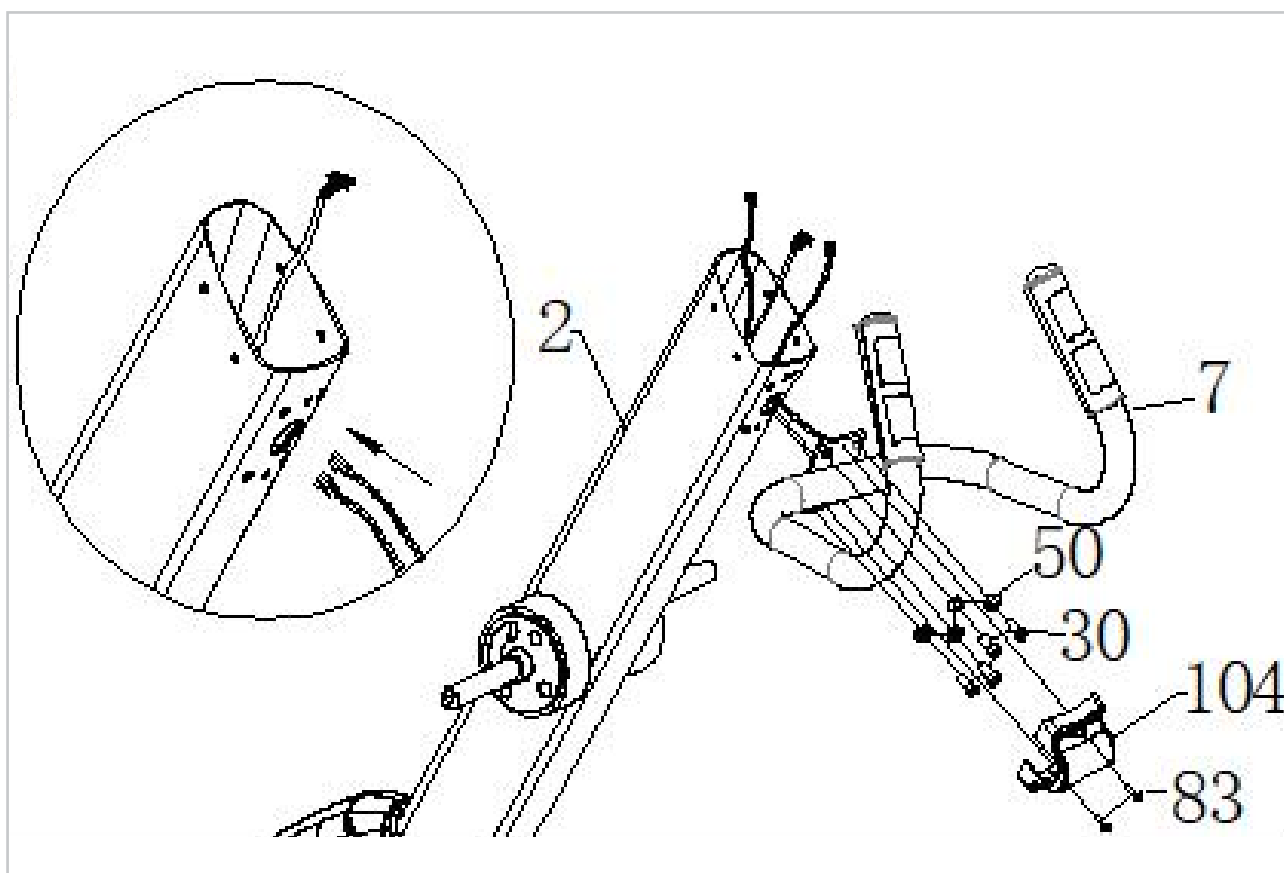

- Attach the pulse circular tube (7) to the upright post (2) with Allen cylinder head full thread screw (30), Flat washer (50).
- Assemble the handlebar cover (104) with Philips pan head full thread screw (118).

STEP 3

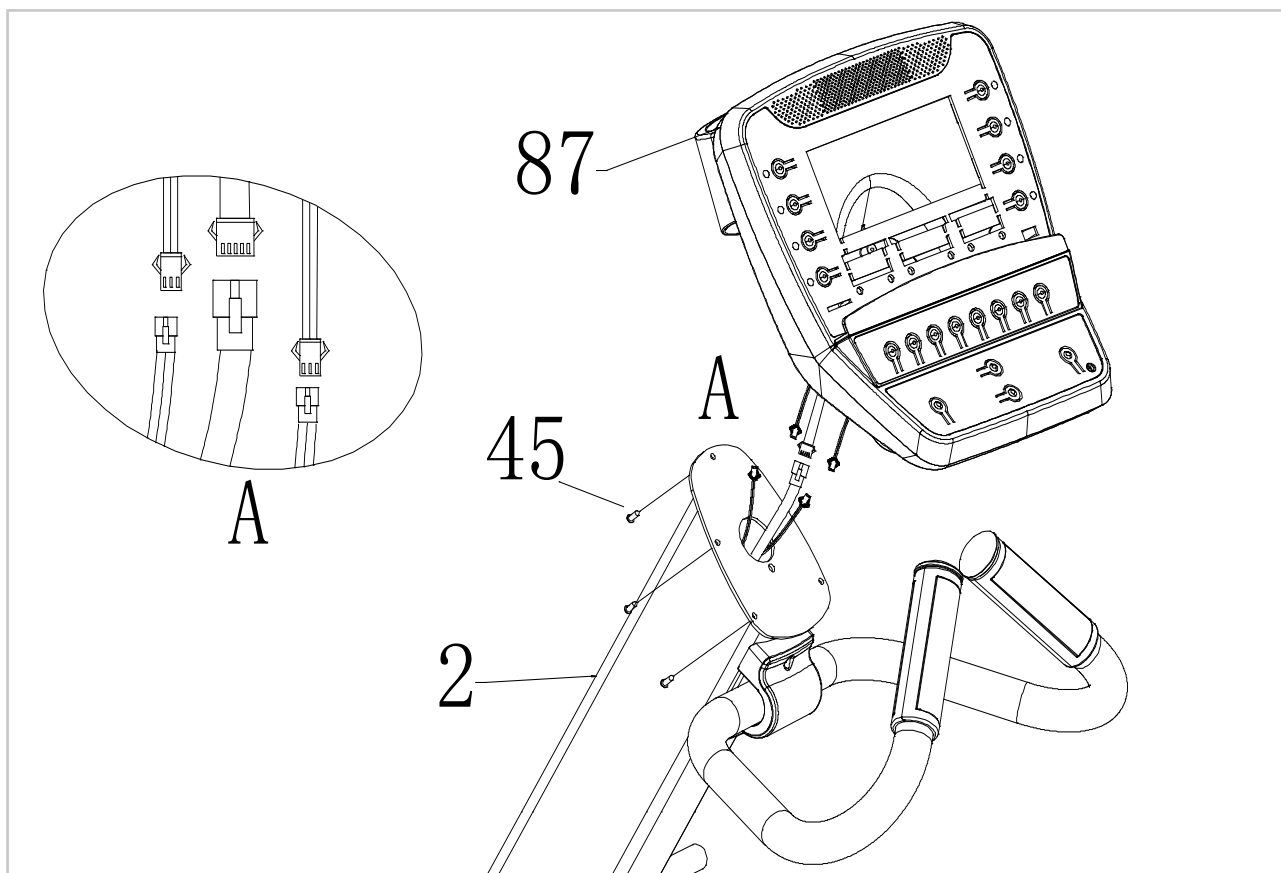

- Connect upright post (2) with console (87) communication wire.
- Attach the console (87) to upright post (2) with the Philips C.K.S. self-tapping screw (45).

STEP 4

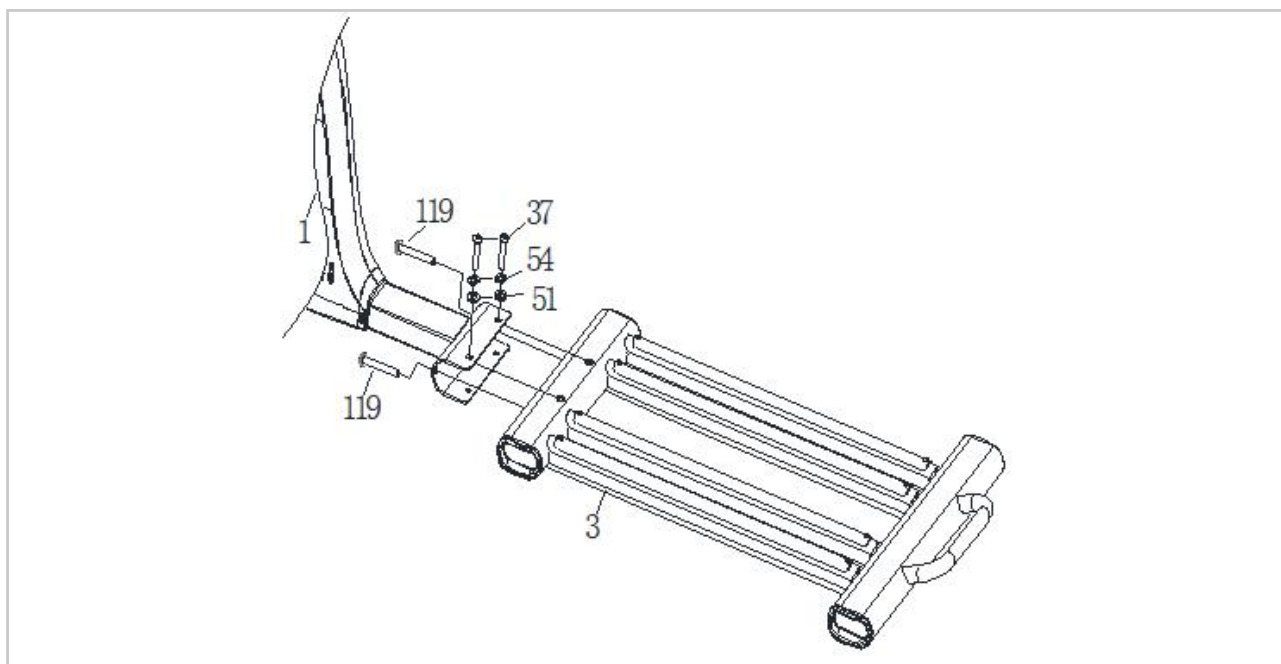

- Assemble Sliding rail group (3) and main frame (1) together, with screw (37) and (119), flat washer (51) and Spring washer (54).

STEP 5

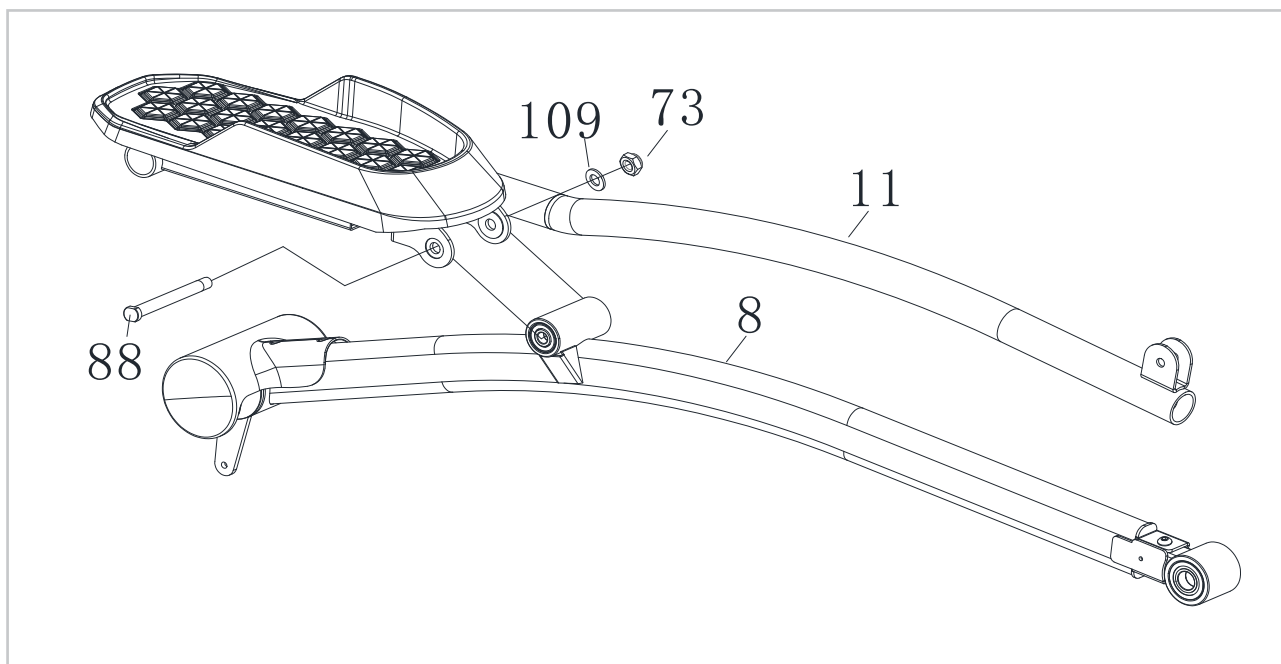

- Assemble swing arm left (11) and body arm left (8) together, with pedal axis (88), flat washer (109) and nut (73).
- Assemble swing arm right (10) and body arm right (9) together, in the same way.

STEP 6

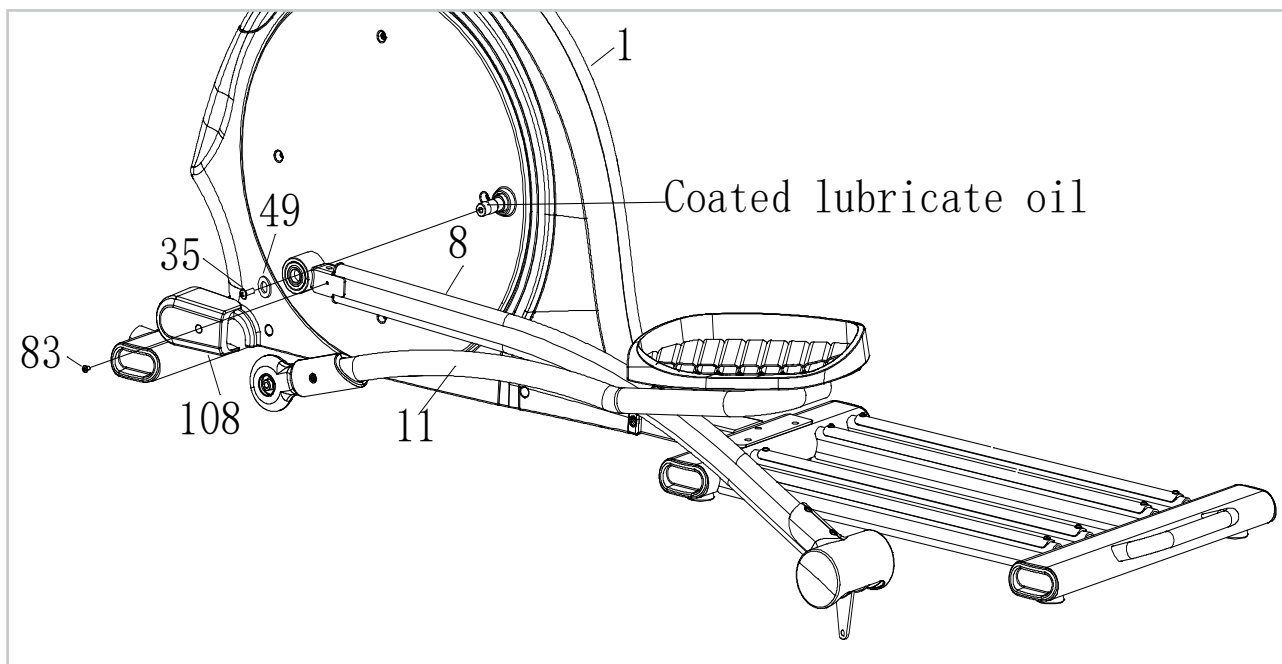

- First apply the lubricating oil to the axis, Attach the left swing arm (8) to main frame (1) with Allen pan head full thread screw (35), Flat washer (49) and decorative cover (108) with Philips pan head full thread screw (83).
- Assemble the right swing arm in the same way.

STEP 7

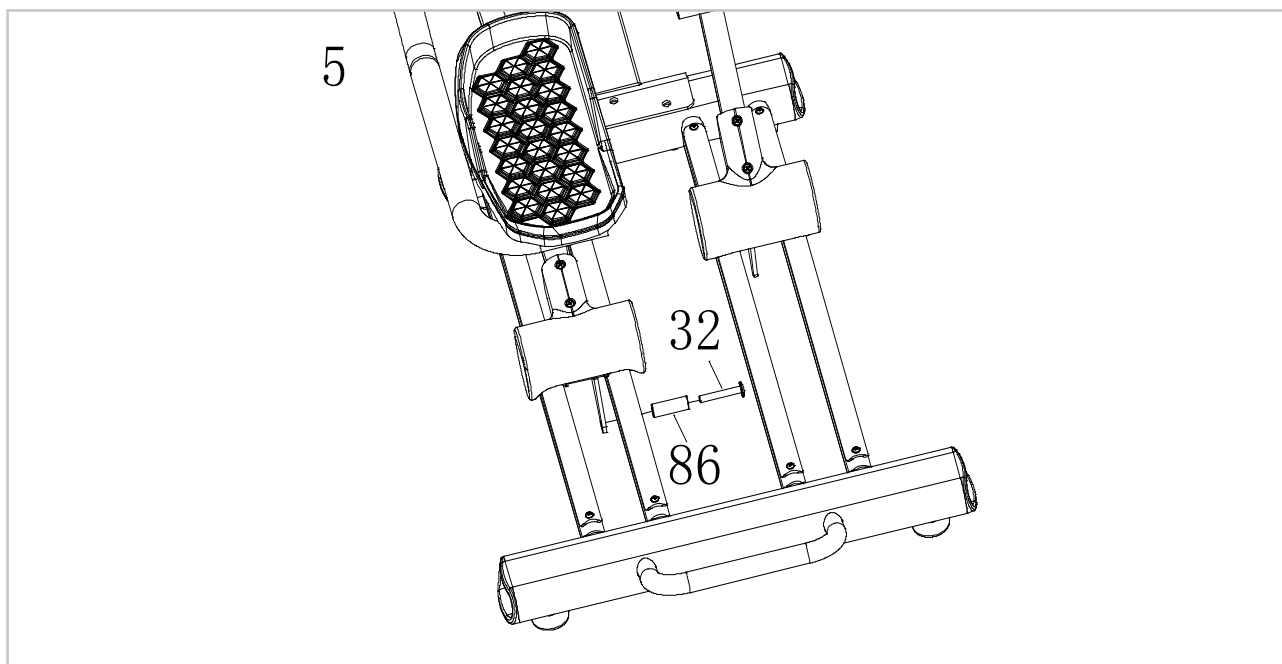

- Attach the Pulley limited sleeve(86) to the swing arm and lock with Allen C.K.S. full thread screw (32).

STEP 8

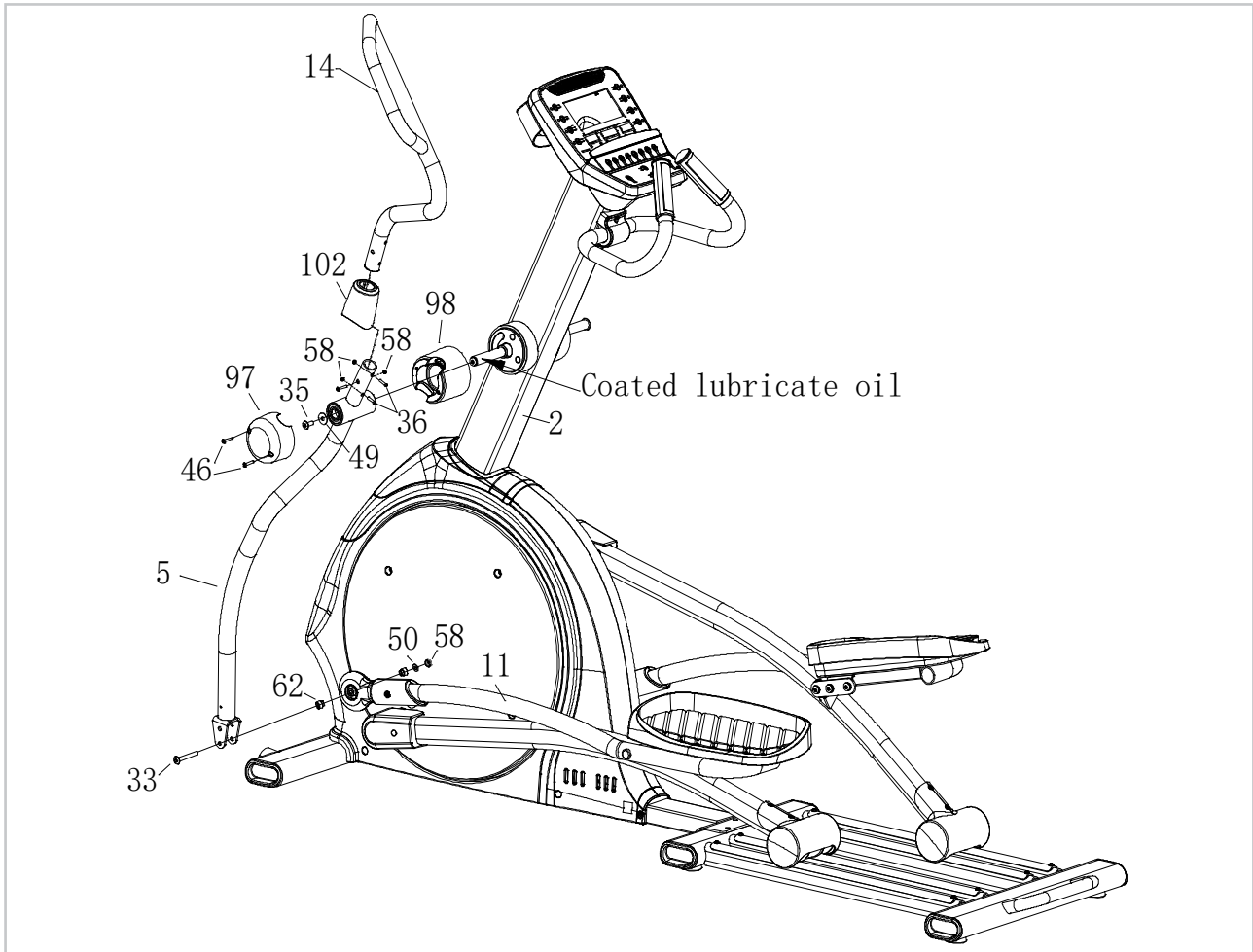

- Assemble left down handlebar (5). First apply the lubricating oil to the axis, then insert the decorative cover (98) into the axis. Then attach the left down handlebar (5) to the axis of upright post (2) with Allen C.K.S. Full thread screw (35), and flat washer (49). **NOTE: The convex side must go forward.**
- Connect the left down handlebar (5) and left swing arm (11) with Allen C.K.S. Full thread screw (33), powder metallurgy case (62), flat washer (50) and Hex self-locking nut (58).
- Assemble the handlebar outer cover (97) with Philips C.K.S. self-locking screw (46).
- Insert the handlebar decorative cover (102) into left upper handlebar (14). Then attach left upper handlebar (14) to left down handlebar (5) with Allen C.K.S. half thread screw (36) and Hex self-locking nut (58).
- Assemble the right down handlebar in the same way.

STEP 9

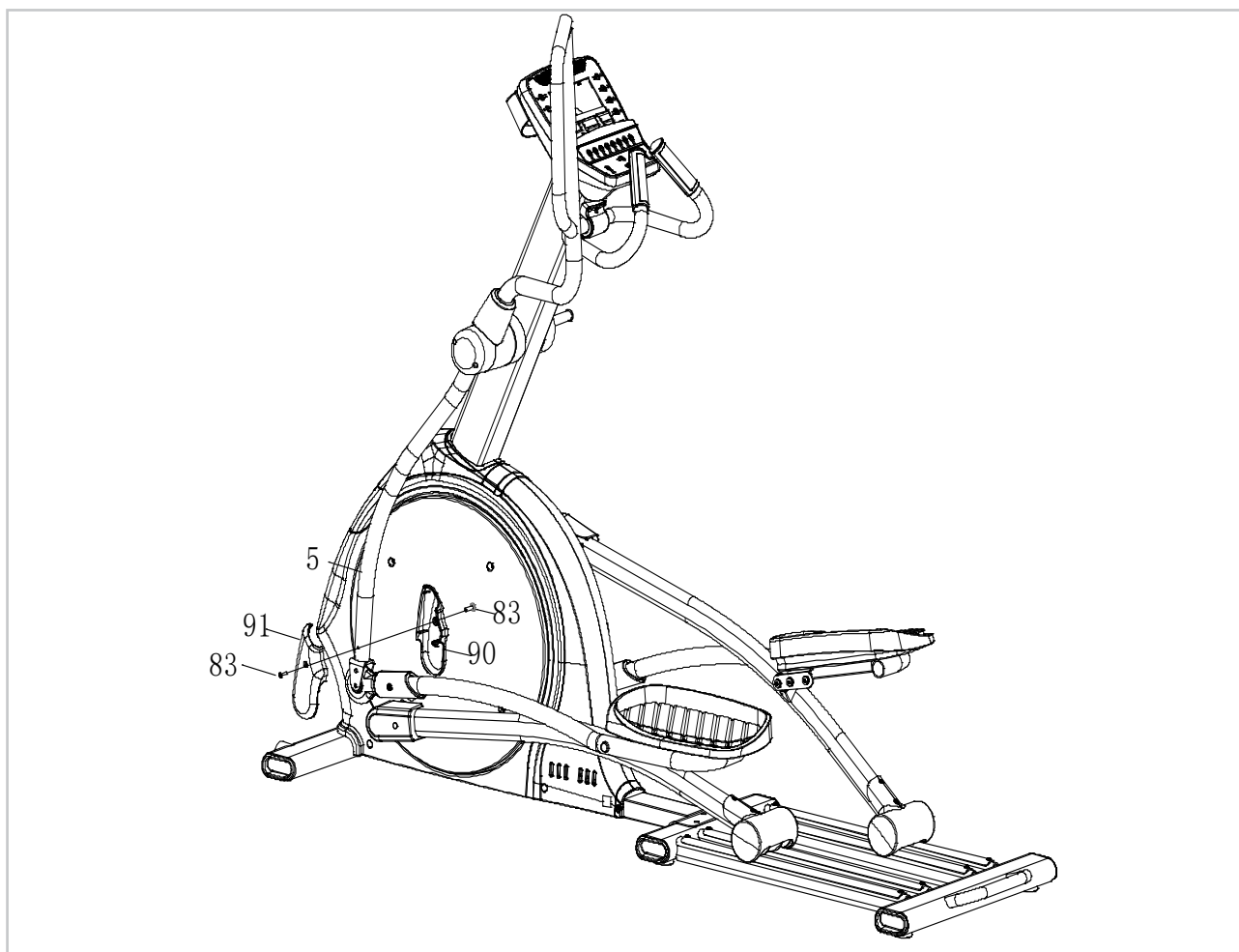

- Assemble left down handlebar cover A (90), B (91). Attach the down handlebar cover A, B to left down handlebar (5) with Philips Pan head full thread screw (83).
- Assemble the right side in the same way.

ADAPTER CONNECTION



- The adapter connection is located on the back of the device (see illustration). Attach the adapter to the adapter connection and connect to the power supply.
- You can now use the elliptical trainer.

Safe and effective use can only be achieved if the device will be assembled and maintained well. It is your responsibility to ensure that the equipment is regularly maintained. Parts that are already used and / or damaged must be replaced before continuing using. The rower machine may only be used indoors and stored away, prolonged exposure to weathering and changes in temperature / humidity can have a serious impact on the electrical components and moving parts of the device.

DAILY MAINTENANCE

- Clean and remove sweat after each use Do not use aggressive cleaning agents and ensure that the device remains free of moisture.
- Check that the rail and the wheels under the seat are free from dust and dirt.

SEMI-ANNUAL MAINTENANCE

- Inspect all bolts and nuts in connection with moving parts of the device, tighten as required.
- Check the mobility of moving parts and components of the use equipment, silicone spray if necessary.

Display shows no values

If the display does not show any values, you can try to check the sensor cables and the cables in the back of the display. If this still does not work, you can move the sensor slightly.

The device beeps

If necessary, lubricate parts with silicone spray. Check that all nuts and bolts are tightened. It may be that a screw is too loose or too tight, this creates friction and makes the device appear to beep. If this is the case, try to find out exactly where the beep comes from and then tighten or loosen this screw. It must always be possible to loosen the screws with your hands. If this is not possible, the screw is too tight.

No resistance

First check whether you can hear the motor running. You will hear the motor running briefly when you increase or decrease the resistance. If you hear the engine running, all electronics are in order, but the V-belt is probably over. You can then open the housing and put the V-belt back on it. If you do not hear the motor running, it is possible that the motor or the display is defective. First check whether the cable running upwards in the pipe is still properly connected.

Ticking sound

It is possible that the flywheel (in the housing) comes against a cable with each pedaling movement. This may be disturbing but will not permanently damage your crosstrainer. To fix this, open the housing and move the cable or fix it with for example a tie wrap.

Heart rate display is not functioning

There can be various reasons for this:

- The sensor cables that run from the heart rate sensor to the display are not properly installed or have become detached during use.
- The sensors may become damp, dirty or greasy. So you have to clean them regularly.

The console is not working

If there is no signal when pedaling, check if the cable is properly attached.

CONSOLE



BUTTON	FUNCTION
MODE/ENTER	Confirm the setting of a training value.
UP/DOWN	Increase or decrease the resistance level.
RESET	<ul style="list-style-type: none"> • Press the button for 2 seconds. The computer will restart at from the setting of the user. • Return to the main menu while setting one training value or during stop mode.
START/STOP	Start or stop the workout.
RECOVERY	Test the heart rate.
BODYFAT	Test body fat and BMI.

FUNCTIONS

FUNCTION	DESCRIPTION
TIME	Displays the training time. Range 0:00 ~ 99:59.
SPEED	Displays the training speed. Range 0.0 ~ 99.9.
DISTANCE	Displays the training distance. Range 0.0 ~ 99.9.
CALORIES	The total calories from the beginning to the end of the workout are shown.
PULSE	<ul style="list-style-type: none"> • Displays the pulse (BPM). • Alarm sounds when the pulse is higher than the preset value.
RPM	Rotation per minute. Range 0 ~ 999.
WATT	Displays the wattage (energy consumption of the workout).
MANUAL	Manual training mode.
PROGRAM	BeginnerX4, AdvancedX4 and SportyX4, 12 programs for selection.
CARDIO	Target HR training mode.

OPERATION

POWER ON

Plug in power supply, computer will power on and display all segments on LCD for 2 seconds. After 4 minutes without pedaling or pulse input, console will enter into power saving mode. Press any key may wake the console up.

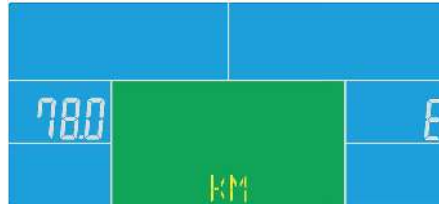
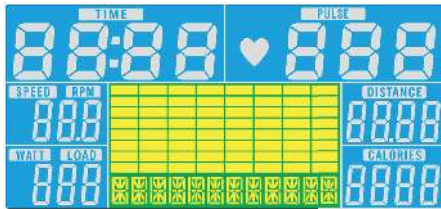

WORKOUT SELECTION

Press UP and Down to select workout Manual - Beginner - Advance - Sporty - Cardio - Watt.

MANUAL MODE

Press START in main menu may start workout in manual mode.

1. Press UP or DOWN to select workout program, choose Manual and press Mode to enter.
2. Press UP or DOWN to preset TIME, DISTANCE, CALORIES, PULSE and press MODE to confirm.
3. Press START/STOP keys to start workout. Press UP or DOWN to adjust load level.
4. Press START/STOP keys to pause workout. Press RESET to reverse to main menu.



BEGINNER MODE

1. Press UP or DOWN to select BEGINNER program, choose BEGINNER 1 ~ 4 and press Mode to enter.
2. Press UP or DOWN to preset TIME.
3. Press START/STOP key to start workout. Press UP or DOWN to adjust load level.
4. Press START/STOP key to pause workout. Press RESET to reverse to main menu.



ADVANCE MODE

1. Press UP or DOWN to select ADVANCE program, choose ADVANCE 1 ~ 4 and press Mode to enter.
2. Press UP or DOWN to preset TIME.
3. Press START/STOP key to start workout. Press UP or DOWN to adjust load level.
4. Press START/STOP key to pause workout. Press RESET to reverse to main menu.



SPORTY MODE

1. Press UP or DOWN to select SPORTY program, choose SPORTY 1 ~ 4 and press Mode to enter.
2. Press UP or DOWN to preset TIME.
3. Press START/STOP key to start workout. Press UP or DOWN to adjust load level.
4. Press START/STOP key to pause workout. Press RESET to reverse to main menu.

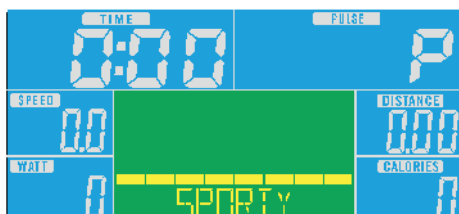

CARDIO MODUS

1. Press UP or DOWN to select workout program, choose CARDIO and press Mode to enter.
2. Press UP or DOWN to set user AGE.
3. Press UP or Down to select 55%.75%.90% or TAG (TARGET H.R.) (default: 100).
4. Press UP or DOWN to preset workout TIME.
5. Press START/STOP key to start or stop workout. Press RESET to reverse to main menu.

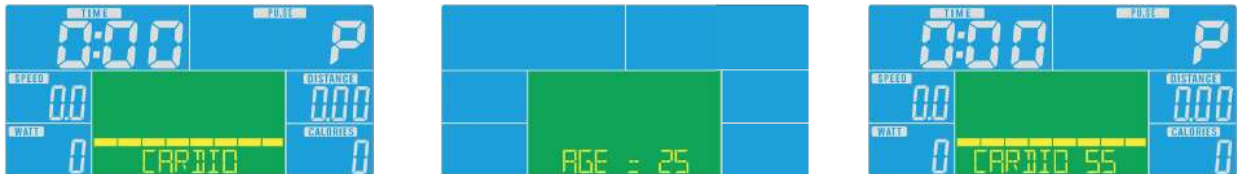

WATT MODUS

1. Press UP or DOWN to select workout program, choose WATT and press Mode to enter.
2. Press UP or DOWN to preset WATT target. (default: 120)
3. Press UP or DOWN to preset TIME.
4. Press START/STOP key to start workout. Press UP or DOWN to adjust Watt level.
5. Press START/STOP key to pause workout. Press RESET to reverse to main menu.



RECOVERY MODE

- After exercising for a period of time, keep holding on hand grips and press "RECOVERY" button. All function display will stop except "TIME" starts counting down from 00:60 to 00:00.
- Screen will display your heart rate recovery status with the F1, F2...to F6. F1 is the best, F6 is the worst. User may keep exercising to improve the heart rate recovery status. Press the RECOVERY button again to return the main display.

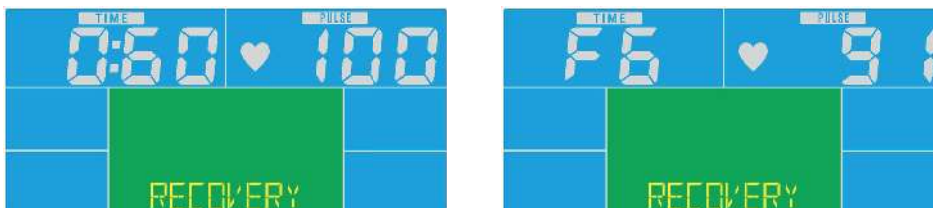

BODY FAT MODE

1. In STOP mode, press the BODY FAT button to start body fat measurement.
2. Then selected user (U1~U4) will blinking for 2 seconds. Then start measuring.
3. During measuring, users have to hold both hands on the handgrip. And the LCD will display "--" for 8 seconds until computer finish measuring.
4. LCD will display BODY FAT advice symbol, BODY FAT percentage, BMI for 30 seconds.
 - "E-1" - Occurs when there is no heart rate signal input detected or user not hold hand grips correctly.
 - "E-4" - Occurs when FAT% exceed setting range (5.0%~ 50%).

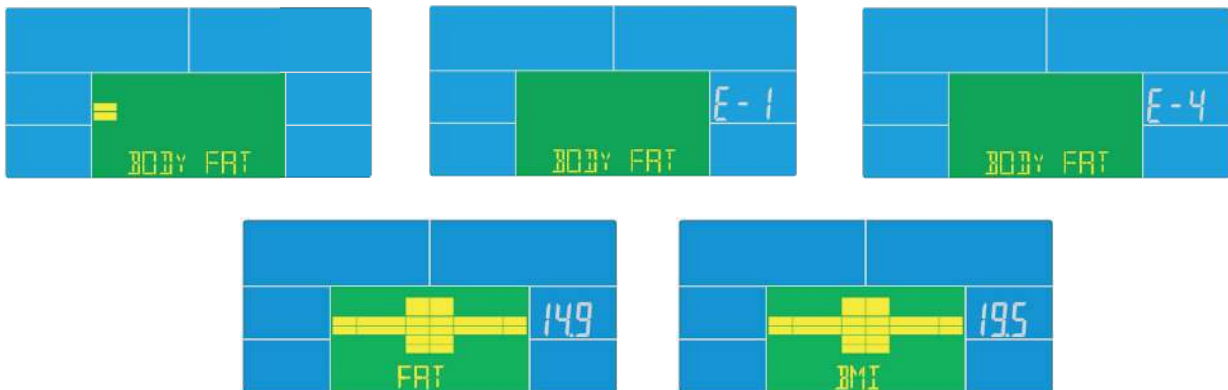

MP3 FUNCTION

The console is with speaker, user can connect mobile or music player to console with an audio cable for MP3 function. Then click the player, console will play music.

REMINDER: Console only has the function of power amplifier but not read memory card.

NOTE:

- After 4 minutes without pedaling or pulse input, console will enter into power saving mode. Press any key may wake the console up.

INSTRUCTION

1. QR code scanner app is required to scan the QR code with an Android or IOS phone or tablet. This app can be downloaded in the App Store or Google Play Store.
2. Scan one of the QR codes below to go directly to the place in the App Store or Google Play Store where the app is located and can be downloaded.
3. Scan the QR code on the right to go to the user manual of the app. The manual describes step by step how the app should be connected to the device, how the app works and what the options are.

ICONSOLE+

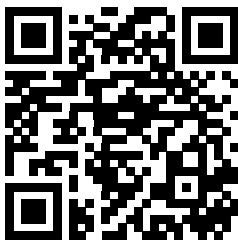

APP STORE
ICONSOLE+



GOOGLE PLAY
ICONSOLE+

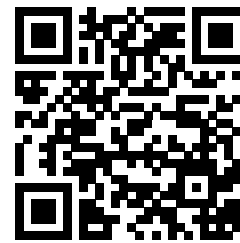

USER MANUAL
ICONSOLE+

KINOMAP

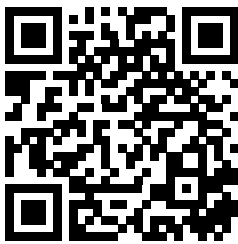

APP STORE
KINOMAP



GOOGLE PLAY
KINOMAP

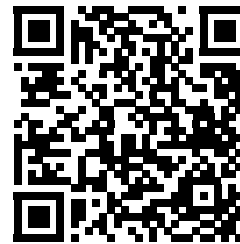

USER MANUAL
KINOMAP

VirtuFit does not provide service for third-party fitness apps such as Kinomap, iConsole, FitShow etc.. If you encounter any troubles with a third-party fitness app, please contact the app developer.

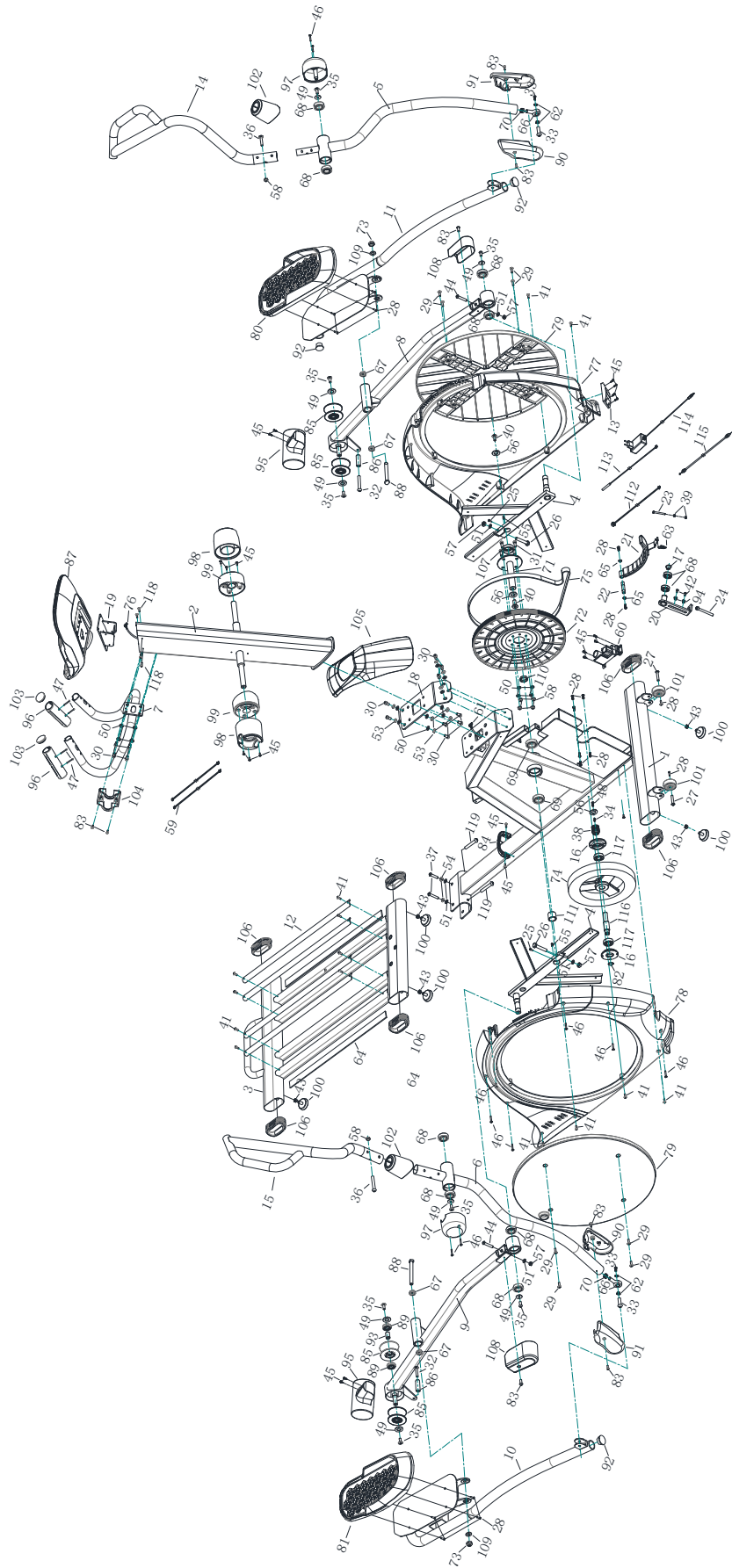

#	DESCRIPTION	QTY
1	Main frame	1
2	Upright post	1
3	Sliding rail	1
4	Crank	2
5	Left lower handlebar	1
6	Right lower handlebar	1
7	Pulse circular tube	1
8	Body arm left	1
9	Body arm right	1
10	Swing arm left	1
11	Swing arm right	1
12	Sliding rail aluminium plate	4
13	Cover decoration	1
14	Left upper handlebar	1
15	Right upper handlebar	1
16	Bearing base	2
17	Circlip for shaft Φ 20	1
18	Upright post connection plate	1
19	Console frame group	1
20	Bearing base	1
21	Magnet fix	1
22	Magnet control fixed axis Φ 12X50	1
23	Screw M5*60	1
24	Screw M10*100*50	1
25	Screw M6*15	2
26	Screw M10*75*20	2
27	Screw Φ 8*33*M6*15	2
28	Screw M6*15	18
29	Screw M6*10	8
30	Screw M8*15	13

#	DESCRIPTION	QTY
31	Screw M8*20	4
32	Screw M8*55*20	2
33	Screw M8*50*20	2
34	Flat key 5*5*20	1
35	Allen CSK full thread screw M8*20	8
36	Screw M8*45*20	6
37	Allen CSK full thread screw M10*70*20	2
38	Small belt pulley	1
39	Hex nut M5	2
40	Allen sunk full thread bolt M8*15	2
41	Screw M5*15	18
42	Screw M5*15	2
43	Hex nut M10	6
44	Screw M10*50*20	2
45	Screw ST4*16	21
46	Screw ST4*20	13
47	Screw ST3*30	4
48	Screw M6*115	1
49	Flat washer Φ 8.2* Φ 25*T2.0	8
50	Flat washer Φ 8	16
51	Flat washer Φ 10	7
52	Spring washer Φ 6	2
53	Spring washer Φ 8	18
54	Spring washer Φ 10	2
55	Flat key 8*10*18	2
56	Flat washer Φ 6* Φ 30*T3.0	3
57	Hex nut M10	4
58	Hex nut M8	11
59	Handle pulse connecting wire	2
60	Engine cable	1

#	DESCRIPTION	QTY
61	Main frame communication cable	1
62	Handlebar connection powder case	4
63	Brake tension spring $\Phi 11.5 \times \Phi 1.2 \times 13$	1
64	EVA washer	4
65	Spring washer $\Phi 12$	2
66	Bearing M12	2
67	Deep groove ball bearing 6201ZZ	4
68	Deep groove ball bearing 6004ZZ	8
69	Deep groove ball bearing 6005ZZ	2
70	Hex nut M12*P1.75	2
71	Belt pulley axle	1
72	Belt pulley	1
73	Hexagon locked nut M12	2
74	Flywheel	1
75	Motor belt	1
76	Connection cable	1
77	Outer cover-left	1
78	Outer cover-right	1
79	Crank cover	2
80	Pedal left	1
81	Pedal right	1
82	Circlip for shaft $\Phi 17$	1
83	Pan head tread screw M5*10	12
84	Outer cover end plug	1
85	Pulley	4
86	Pulley limited sleeve	2
87	Console	1
88	Pedal axis	2
89	Deep groove ball bearing R10ZZ	4
90	Down handlebar cover A	2
91	Down handlebar cover B	2

#	DESCRIPTION	QTY
92	Body arm A	4
93	Body arm B	2
94	Belt clam powder set	2
95	Wheels decoration cover	2
96	Handle pulse set	2
97	Handle outer cover	2
98	Handle middle cover	2
99	Handle inner cover	2
100	Foot pads	6
101	Wheels	2
102	Handlebar decorative cover	2
103	End cap	2
104	Handlebar cover	1
105	Upright post cover	1
106	Elliptical tube plug	6
107	Crank clearance set three	1
108	Body arm cover	2
109	Flat washer $\Phi 12$	2
110	Crank clearance 1	1
111	Crank clearance 2	1
112	Power communication wire	1
113	Magnetic sensor	1
114	Power adapter	1
115	Brake line	1
116	Flywheel axis	1
117	Deep groove bearing (TPI) 6203ZZ	2
118	Pan head full thread screw M5*15	4
119	Allen CKS half thread bolt M10*115*20	2

A successful exercise program consists of a warm-up, aerobic exercise, and a cool-down. Do the entire program at least two and preferably three times a week, resting for a day between workouts. After several months, you can increase your workouts to four or five times per week.

WARMING UP

The purpose of warming up is to prepare your body for exercise and to minimize injuries. Warm up for two to five minutes before strength-training or aerobic exercising. Perform activities that raise your heart rate and warm the working muscles. Activities may include brisk walking, jogging, jumping jacks, jump rope, and running in place.

STRETCHEN

Stretching while your muscles are warm after a proper warm-up and again after your strength or aerobic training session is very important. Muscles stretch more easily at these times because of their elevated temperature, which greatly reduces the risk of injury. Stretches should be held for 15 to 30 seconds.

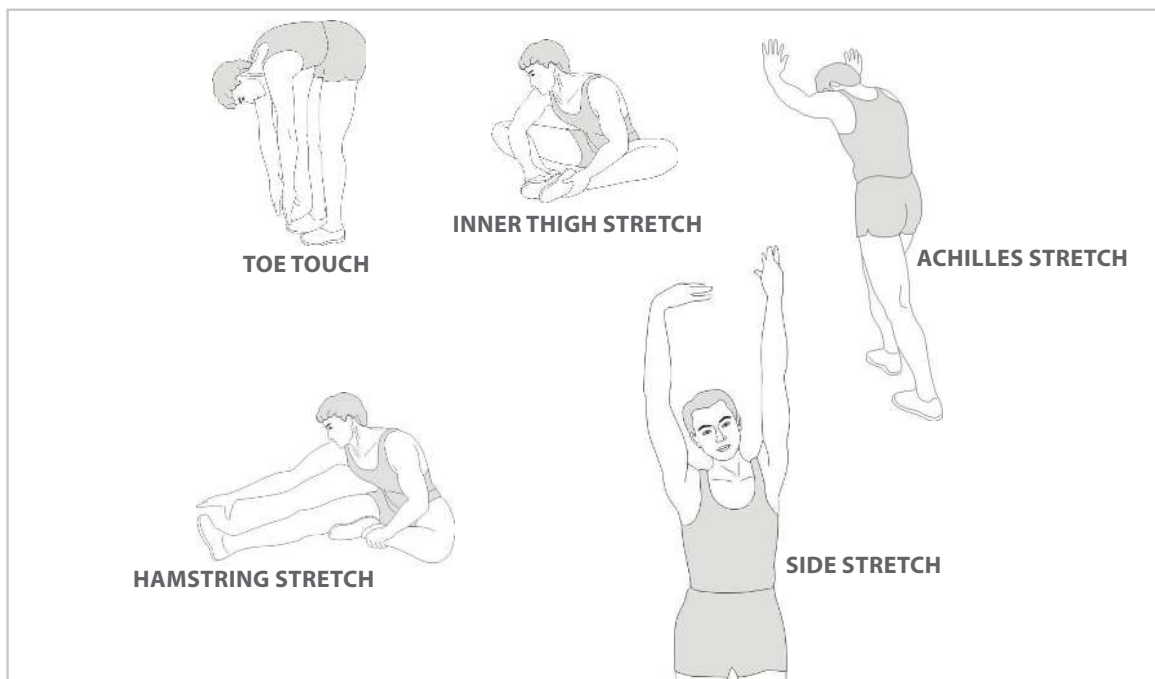

COOLING DOWN

The purpose of cooling down is to return the body to its normal or near normal, resting state at the end of each exercise session. A proper cool-down slowly lowers your heart rate and allows blood to return to the heart.

DECLARATION OF THE MANUFACTURER

VirtuFit hereby declares that this product complies with the following standards and directives:

- EN ISO 20957
- EMC (2014/30/EU)
- Low Voltage Directive (2014/35/EU)
- Radio Equipment Directive (2014/53/EU)
- RoHS (2011/65/EU and 2015/863)

As a result, the product is CE-certified.

The logo for VirtuFit features the brand name in a bold, lowercase, sans-serif font. The letters are a vibrant green color. A thick, white, curved line sweeps across the middle of the text, starting from the left and ending on the right, creating a sense of motion and energy.

For questions or missing parts please contact your dealer.