

N625P307348Z/N625P307349Z

Product manual
Gebrauchsanweisung
Manuel du produit
Manual del producto
Manuale del prodotto

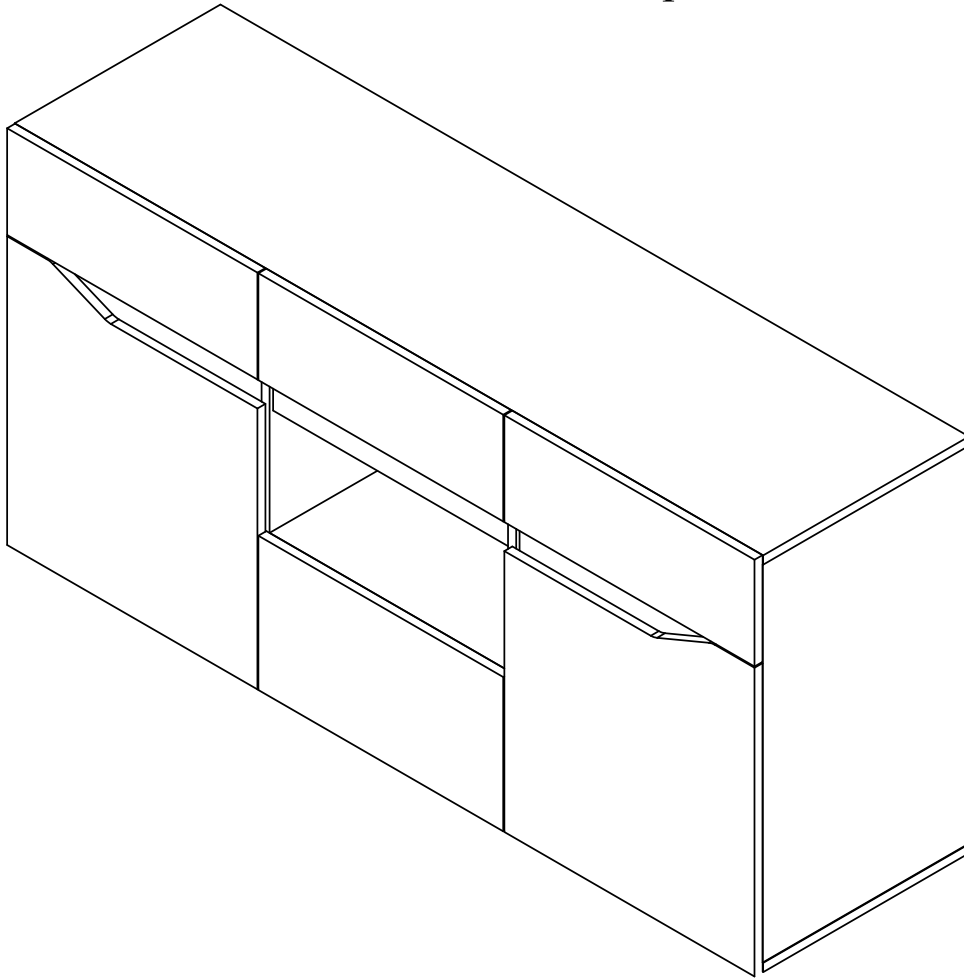

EN:Our product will be delivered to you in 2 packages.The delivery times of these 2 packages may differ, please be patient and thank you for your understanding

FR:Notre produit vous sera livré en 2 colis.Les delais de livraison de ces 2 colis peuvent différer, soyez patient et merci de votre compréhension.

DE:Unser Produkt wird Ihnen in 2 Paketen geliefert.Die Lieferzeiten dieser 2 Paketekönnenabweichen,bitte haben Sie etwas Geduld und vielen Dank für Ihr Verständnis

IT:I nostri prodotti vengono trasportati in due pacchetti. I tempi di consegna dei due pacchetti sono diversi abbiate pazienza e vi ringrazio per la vostra comprensione.

ES:Nuestro producto se entrega en dos paquetes. El tiempo de entrega de estos dos paquetes es diferente. Por favor sea paciente. Gracias por su comprensión.



2PERS



45 MIN

Tool Required Not Provided

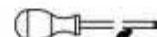
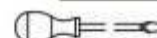



[DE]

Warnung: Lesen Sie diese Anleitung vor dem Zusammenbau bitte vollständig durch. Überprüfen Sie, ob Sie alle auf den Seiten aufgeführten Komponenten und Werkzeuge haben. Bewahren Sie die Anleitung zum späteren Nachschlagen auf. Teile des Zusammenbaus lassen sich mit 2 Personen leichter durchführen. Suchen Sie bei Bedarf professionelle Hilfe.

Warnung: Legen Sie alle Teile auf eine ebene Fläche. Legen Sie eine weiche Decke oder Ähnliches darunter, um sie vor Kratzern oder Flecken zu schützen. Vermeiden Sie es, Komponenten über den Boden zu ziehen oder zu schieben.

Warnung: Überprüfen Sie regelmäßig alle Beschläge und Befestigungen, um sicherzustellen, dass sie sicher sind und um Unfälle zu vermeiden. Wenn Teile fehlen, kaputt, beschädigt oder abgenutzt sind, verwenden Sie das Produkt nicht weiter, bis es mit vom Hersteller autorisierten Teilen repariert wurde.

Warnung: Lassen Sie Kinder nicht auf die Möbel klettern, da dies zum Umkippen und zu schweren Verletzungen führen kann. Bauen Sie die Möbel außerhalb der Reichweite von Kindern zusammen.

Warnung: Stellen Sie die Möbel nicht in die Nähe von Feuerquellen oder heißen Gegenständen, um Brandgefahr zu vermeiden.

Warnung: Reinigen Sie die Möbel mit einem feuchten Tuch oder Alkohol. Verwenden Sie keine Reinigungsmittel mit ätzenden Chemikalien.

Warnung: Dieses Produkt ist mit einer Kippenschutzvorrichtung ausgestattet. Bitte installieren Sie diese Vorrichtung unbedingt, um unnötige Verletzungen durch Umkippen zu vermeiden.

[EN]

Warning: Please read these instructions fully before starting assembly. Check you have all the components and tools listed on pages. Keep the instructions for later reference. Parts of the assembly will be easier with 2 people. Seek professional assistance if necessary.

Warning: Please place all parts on a flat surface. Place a soft blanket or similar underneath to protect against scratches or stains. Avoid dragging or sliding components across the floor.

Warning: Regularly check all fittings and fastenings to ensure they are secure and to prevent accidents. If any parts are missing, broken, damaged, or worn, discontinue use of the product until repairs have been made using factory authorized parts.

Warning: Do not allow children to climb on the furniture as this may result in tipping and serious personal injury. Assemble the furniture away from the reach of children.

Warning: Do not place furniture close to fire sources or high-temperature objects to avoid the risk of fire. Do not place furniture in damp environments to prevent material damage.

Warning: Clean furniture with a damp cloth or alcohol, avoid using cleaning agents containing corrosive chemicals.

Warning: This product is equipped with an anti-tilt device. Please be sure to install this device to prevent unnecessary injuries caused by tipping.

[FR]

Avertissement : Veuillez lire attentivement ces instructions avant de commencer l'assemblage. Vérifiez que vous disposez de tous les composants et outils répertoriés sur les pages. Conservez les instructions pour référence ultérieure. Certaines parties de l'assemblage seront plus faciles à 2 personnes. Demandez l'aide d'un professionnel si nécessaire.

Avertissement : Veuillez placer toutes les pièces sur une surface plane. Placez une couverture douce ou similaire en dessous pour les protéger des rayures ou des taches. Évitez de faire glisser les composants sur le sol.

Avertissement : Vérifiez régulièrement tous les raccords et fixations pour vous assurer qu'ils sont bien fixés et pour éviter les accidents. Si des pièces manquent, sont cassées, endommagées ou usées, cessez d'utiliser le produit jusqu'à ce que des réparations aient été effectuées à l'aide de pièces autorisées par l'usine.

Avertissement : Ne laissez pas les enfants grimper sur les meubles car cela pourrait entraîner un basculement et des blessures graves. Assemblez les meubles hors de portée des enfants.

Avertissement : Ne placez pas les meubles à proximité de sources de feu ou d'objets à haute température pour éviter tout risque d'incendie.

Avertissement : Nettoyez les meubles avec un chiffon humide ou de l'alcool, évitez d'utiliser des produits de nettoyage contenant des produits chimiques corrosifs.

Avertissement : Ce produit est équipé d'un dispositif anti-basculement. Assurez-vous d'installer ce dispositif pour éviter les blessures inutiles causées par un basculement.

[IT]

Attenzione: leggere attentamente queste istruzioni prima di iniziare il montaggio. Verificare di avere tutti i componenti e gli strumenti elencati nelle pagine. Conservare le istruzioni per riferimento futuro. Alcune parti del montaggio saranno più facili con 2 persone. Se necessario, chiedere assistenza professionale.

Attenzione: posizionare tutte le parti su una superficie piana. Posizionare una coperta morbida o simile sotto per proteggere da graffi o macchie. Evitare di trascinare o far scivolare i componenti sul pavimento.

Attenzione: controllare regolarmente tutti i raccordi e i dispositivi di fissaggio per assicurarsi che siano sicuri e per prevenire incidenti. Se alcune parti sono mancanti, rotte, danneggiate o usurate, interrompere l'uso del prodotto fino a quando non siano state eseguite le riparazioni utilizzando parti autorizzate dalla fabbrica.

Attenzione: non consentire ai bambini di arrampicarsi sui mobili poiché ciò potrebbe causare ribaltamenti e gravi lesioni personali. Montare i mobili lontano dalla portata dei bambini.

Attenzione: non posizionare i mobili vicino a fonti di fuoco o oggetti ad alta temperatura per evitare il rischio di incendio

Attenzione: pulire i mobili con un panno umido o alcol, evitare di utilizzare detergenti contenenti sostanze chimiche corrosive.

Attenzione: questo prodotto è dotato di un dispositivo antiribaltamento. Assicurarsi di installare questo dispositivo per prevenire lesioni inutili causate dal ribaltamento.

[ES]

Advertencia: Lea estas instrucciones completamente antes de comenzar el montaje. Compruebe que tiene todos los componentes y herramientas que se enumeran en las páginas. Conserve las instrucciones para consultarlas más adelante. El montaje de algunas partes será más sencillo con 2 personas. Busque ayuda profesional si es necesario.

Advertencia: Coloque todas las piezas sobre una superficie plana. Coloque una manta suave o algo similar debajo para protegerlas de rayones o manchas. Evite arrastrar o deslizar los componentes por el piso.

Advertencia: Verifique regularmente todos los accesorios y fijaciones para asegurarse de que estén seguros y evitar accidentes. Si falta alguna pieza, está rota, dañada o desgastada, deje de usar el producto hasta que se hayan realizado las reparaciones con piezas autorizadas de fábrica.

Advertencia: No permita que los niños se suban a los muebles, ya que esto puede provocar que se vuelquen y lesiones personales graves. Monte los muebles fuera del alcance de los niños.



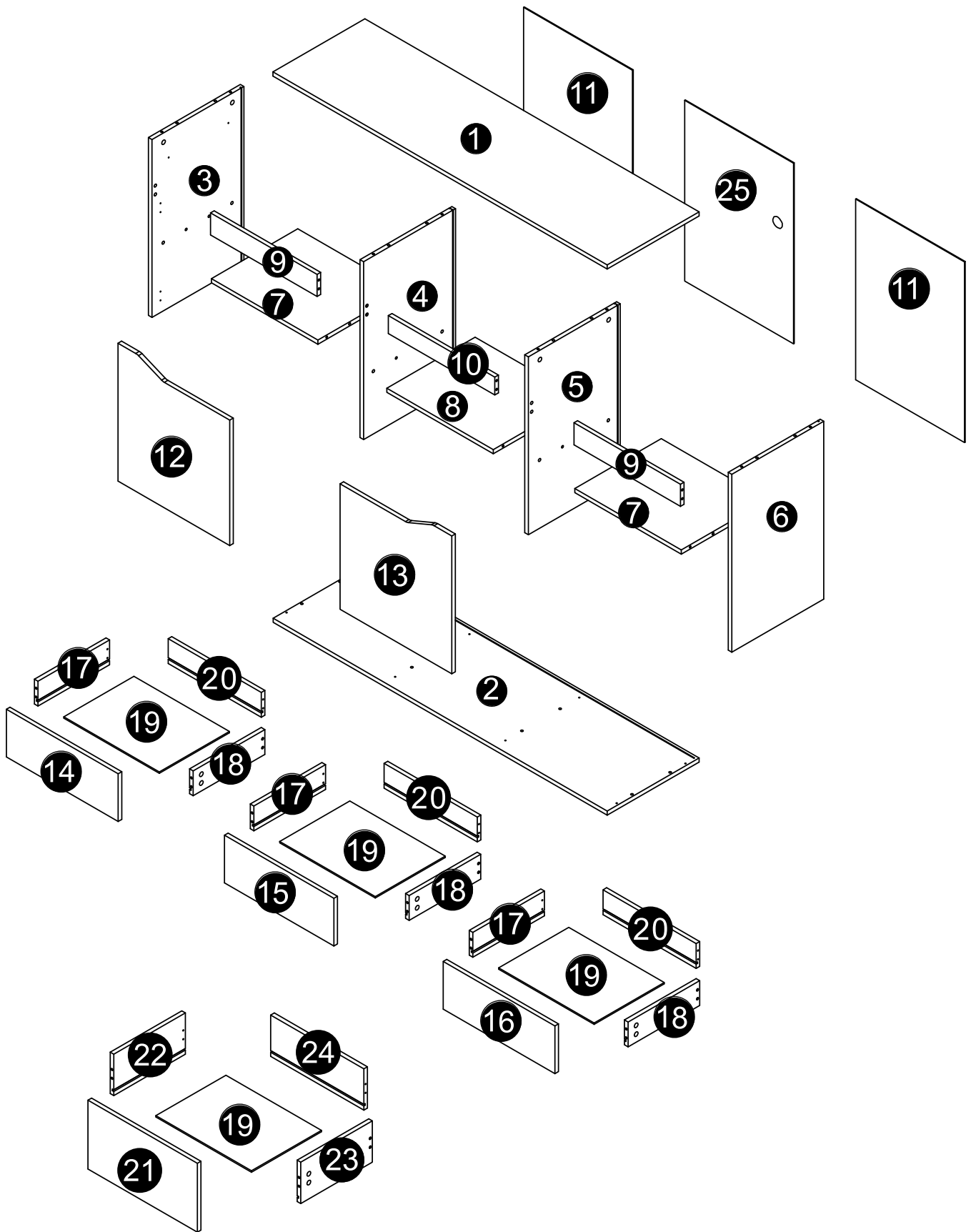

Advertencia: No coloque los muebles cerca de fuentes de fuego u objetos de alta temperatura para evitar el riesgo de incendio.

Advertencia: Limpie los muebles con un paño húmedo o alcohol, evite usar agentes de limpieza que contengan químicos corrosivos.

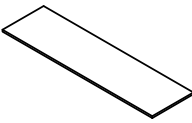
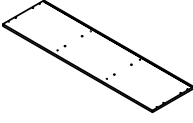
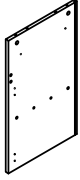

Advertencia: Este producto está equipado con un dispositivo antivuelco. Asegúrese de instalar este dispositivo para evitar lesiones innecesarias causadas por vuelcos.







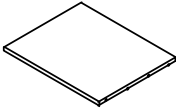
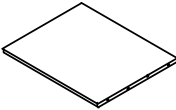
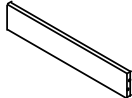
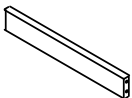

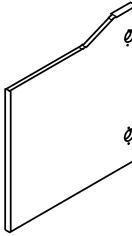
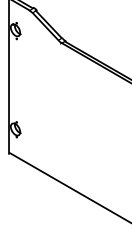
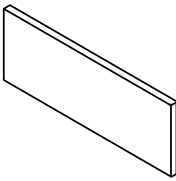
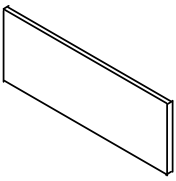
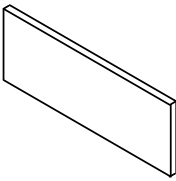
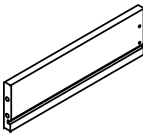
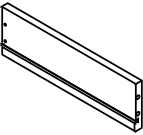
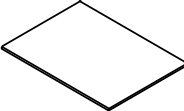
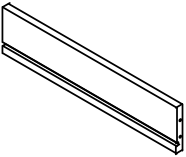
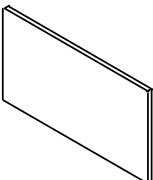
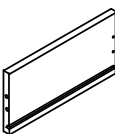
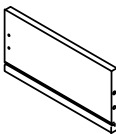
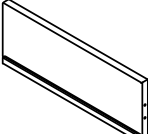
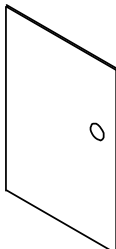



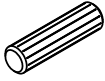
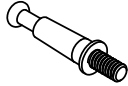

DE:Teilleiste für / EN:Parts List for / FR:Liste des pièces pour / IT:Elenco delle parti per /ES:Lista de piezas para
N625P307348Z

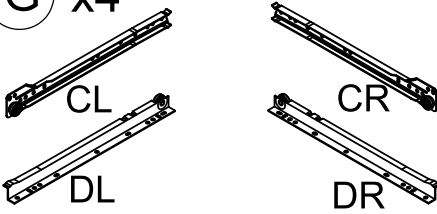
						
① x1	② x1	③ x1	④ x1	⑤ x1	⑥ x1	

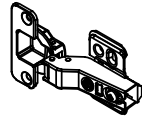
DE:Teilleiste für / EN:Parts List for / FR:Liste des pièces pour / IT:Elenco delle parti per /ES:Lista de piezas para
N625P307349Z

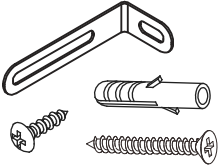
						
⑦ x2	⑧ x1	⑨ x2	⑩ x1	⑪ x2	⑫ x1	⑬ x1
						
⑭ x1	⑮ x1	⑯ x1	⑰ x3	⑱ x3	⑲ x4	⑳ x3
						
⑳ x1	㉑ x1	㉒ x1	㉓ x1	㉔ x1		

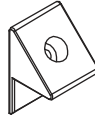
DE:Hardwareliste für / EN:Hardware List for / FR:Liste du matériel pour / IT:Elenco hardware per / ES:Lista de hardware para N625P307349Z

<p>A x28</p> 	<p>B x48</p> 	<p>C x48</p> 	<p>D x12</p> 	<p>E x24</p> 	<p>F x56</p> 
<p>φ8*40</p>			<p>φ4*25</p>	<p>φ3.5*35</p>	<p>φ3.5*14</p>
<p>G x4</p> 		<p>H x6</p> 	<p>I x4</p> 	<p>J x48</p> 	<p>K x2</p> 
<p>300mm</p>					
<p>L x1</p> 		<p>M x12</p> 	<p>N x12</p> 	<p>P x5</p> 	
<p>440mm</p>		<p>φ3.5*14</p>			

EN:If you find that the white glue particles on the board are missing, please press part P into the board.
 DE:Sollten Sie feststellen, dass die weißen Gummipartikel auf der Platine fehlen, drücken Sie bitte Teil P in die Platine.
 FR:Si vous constatez qu'il manque des particules de caoutchouc blanc sur le tableau, veuillez enfoncer la partie P dans le tableau.
 IT:Se trovi che mancano le particelle di gomma bianca sulla tavola, premi la parte P sulla tavola.
 ES:Si descubre que faltan las partículas de goma blancas en el tablero, presione la parte P en el tablero.

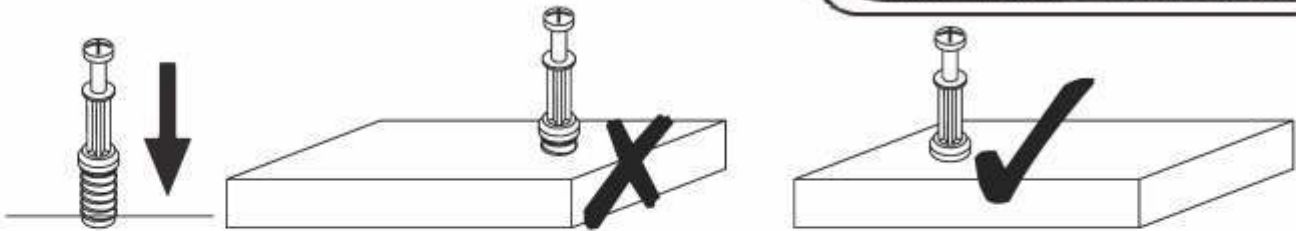

EN_QUICKFIT: Tighten quickfit until shoulder is flush with panel. Do not overtighten or undertighten.

FR_RACCORD RAPIDE: Faites serrer le raccord rapide jusqu'à ce que l'épaulement soit parfaitement encastré dans le panneau. Il ne faut ni trop serrer ni insuffisamment serrer.

ES_QUICKFIT: Apriete quickfit hasta que el hombro se descargue con el panel. NO lo sobreapriete ni lo apriete poco.

DE_QUICKFIT: Ziehen Sie den Quickfit fest, bis die Schulter mit der Platte bündig ist. Bitte nicht zu fest oder zu schwach anziehen.

IT_MONTAGGIO RAPIDO: Stringere il montaggio rapido fino a quando la spalla è a filo con il pannello, non stringere troppo o troppo poco.



EN_CAM LOCK: When fitting cam lock, ensure starting position is correct before you insert connecting quickfit.

FR_SERRURE BATTEUSE: Avant d'insérer la serrure batteuse, veillez à la bonne orientation avant d'insérer le raccord rapide.

ES_CIERRE DE LA CÁMARA: Cuando instale el cierre de la cámara, asegúrese de que la posición de inicio es correcta antes de que inserte el quickfit conector.

DE_CAM-LOCK: Achten Sie bei der Montage des Cam-Locks auf die richtige Ausgangsposition, bevor Sie den Quickfit einsetzen.

IT_BLOCCAGGIO A CAMMA: Quando si monta il bloccaggio a camma, assicurarsi che la posizione iniziale sia corretta prima di inserire il montaggio rapido di collegamento.

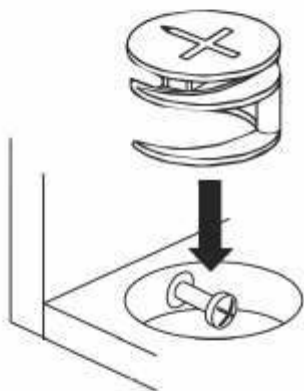

EN_Quickfit head should be in the centre of the cam lock when the two panels are joined.

Cam lock should be inserted before quickfit.

FR_Lorsque les deux panneaux sont assemblés, la tête du raccord rapide doit reposer au centre de la serrure batteuse. Il faut insérer la serrure batteuse avant le raccord rapide.

ES_El cabezal del quickfit debe estar en el centro del cierre de la cámara cuando se unan los dos paneles.

Se debe insertar el cierre de la cámara antes que el quickfit.

DE_Der Quickfit-Kopf sollte sich in der Mitte des Cam-Locks befinden, wenn die beiden Platten zusammengefügt sind.

Der Cam-Lock sollte vor dem Quickfit eingesetzt werden.

IT_La testa del montaggio rapido deve trovarsi al centro del bloccaggio a camma quando i due pannelli sono uniti.

Il Bloccaggio a Camma deve essere inserito prima del montaggio rapido.

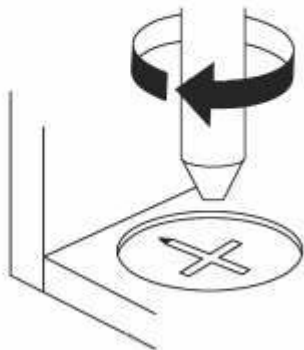

EN_Turn cam lock clockwise to tighten.

FR_Faites tourner la serrure batteuse dans le sens des aiguilles d'une montre pour la resserrer.

ES_Gire el cierre de la cámara en sentido horario para apretarlo.

DE_Drehen Sie den Cam-Lock im Uhrzeigersinn, um ihn festzuziehen.

IT_Ruotare il bloccaggio a camma in senso orario per stringere.

EN It may be necessary to adjust the hinges so that the doors align. Use the instructions below as a guide.

FR Il est parfois nécessaire d'ajuster les charnières pour un meilleur alignement des portes. Servez-vous des instructions ci-dessous comme guide.

ES Puede que sea necesario ajustar los quicios de forma que se alineen las puertas. Use las instrucciones que aparecen debajo como guía.

DE Möglicherweise müssen Sie die Scharniere so einstellen, dass die Türen ausgerichtet sind. Verwenden Sie die nachstehenden Anweisungen als Leitfaden.

IT Potrebbe essere necessario regolare le cerniere in modo che le porte siano allineate. Per fare ciò attenersi alle istruzioni sottostanti.

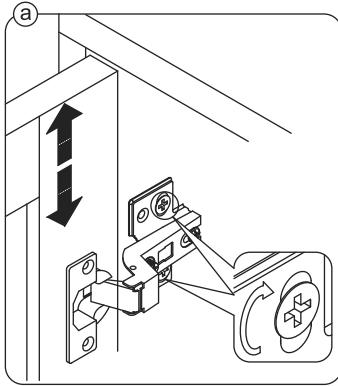

EN To adjust the door vertically loosen the screw as shown and move up and down as needed.

FR Si vous souhaitez régler la porte **verticalement**, desserrez la vis comme indiqué et déplacez la porte de haut en bas selon les besoins.

ES Para ajustar la puerta **verticalmente** afloje el tornillo tal y como se muestra y muévalo hacia arriba o hacia abajo según sea necesario.

DE Um die Tür **vertikal** auszurichten, lösen Sie die Schraube wie abgebildet und bewegen Sie sie nach Bedarf nach oben oder nach unten.

IT Per allineare la porta **verticalmente** allentare la vite come mostrato e spostarla in alto o in basso secondo necessità.

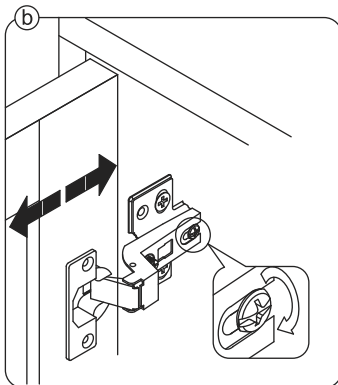

EN To adjust the gap from the door to the main frame turn the screw clockwise or anti-clockwise as needed.

FR Si vous souhaitez ajuster l'**écart** entre la porte et le cadre principal, tournez la vis dans le sens des aiguilles d'une montre ou dans le sens inverse, si nécessaire.

ES Para ajustar el **espacio** desde la puerta al marco principal, gire el tornillo en sentido horario o antihorario, según se necesite.

DE Um den **Abstand** von der Tür zum Hauptrahmen auszurichten, drehen Sie die Schraube je nach Bedarf im oder gegen den Uhrzeigersinn.

IT Per regolare lo **spazio** tra la porta e il telaio principale, avvitare o svitare la vite secondo necessità.

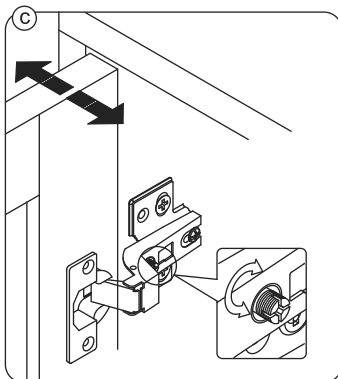

EN To adjust the door laterally adjust the screw as shown by turning clockwise or anti-clockwise.

FR Si vous souhaitez ajuster la porte **latéralement**, ajustez la vis comme indiqué en tournant dans le sens des aiguilles d'une montre ou dans le sens inverse des aiguilles d'une montre.

ES Para ajustar la puerta **lateralmente** ajuste el tornillo tal y como se muestra girándolo en sentido horario y antihorario.

DE Um die Tür **seitlich** auszurichten, stellen Sie bitte die Schraube wie abgebildet durch Drehen im oder gegen den Uhrzeigersinn ein.

IT Per allineare la porta **lateralmente** regolare la vite come mostrato, avvitandola o svitandola.

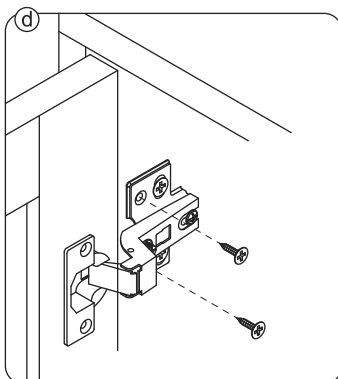

EN Please fix other screws

FR Merci de serrer les autres vis.

ES Fije los demás tornillos

DE Befestigen Sie bitte die anderen Schrauben

IT Fissare le altre viti

01

Ax12



Bx24

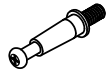

$\phi 8 \times 40$

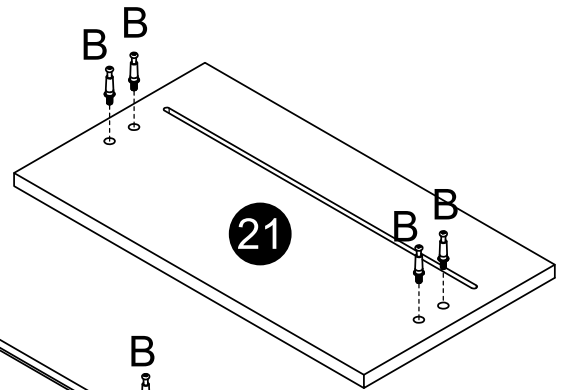
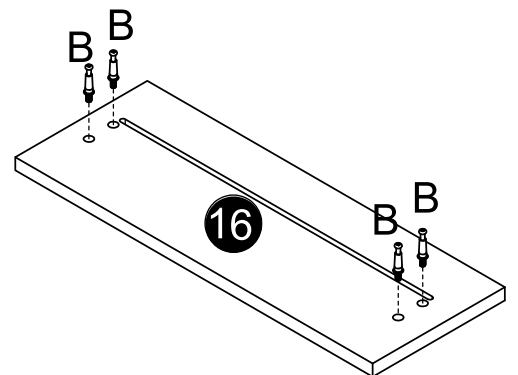
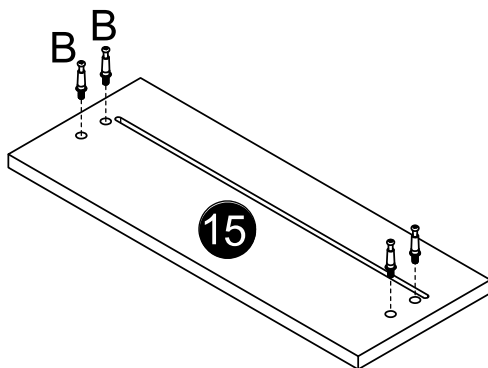
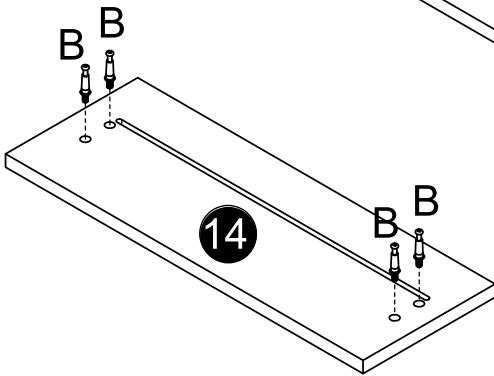
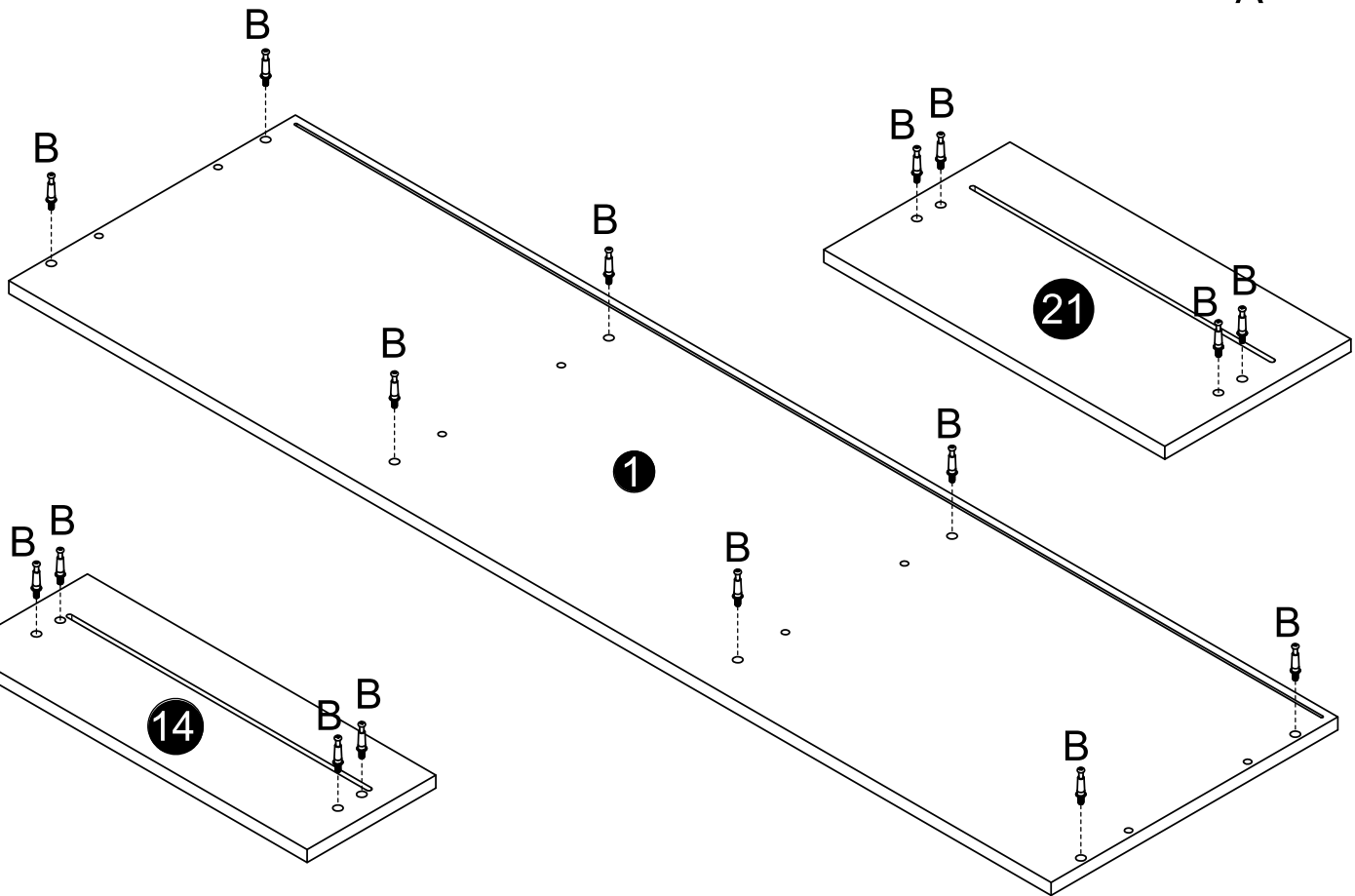
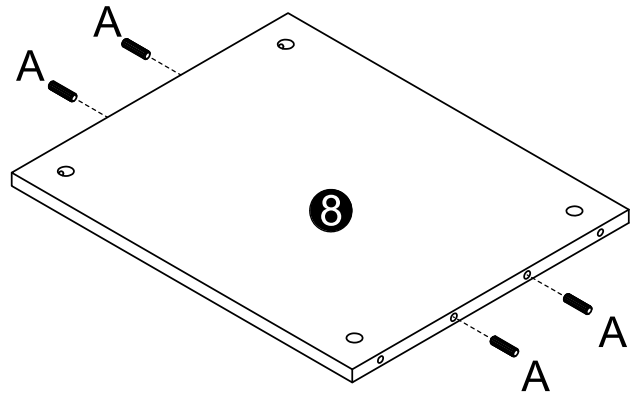
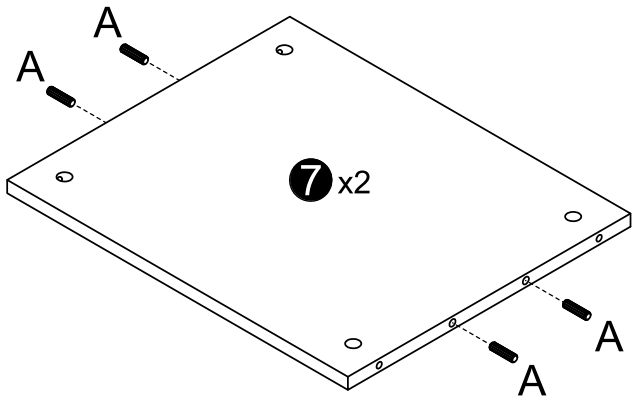

02

Ax8



$\phi 8 \times 40$

Bx8



Fx4



$\phi 3.5 \times 14$

G1x1



CL

G2x1

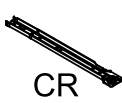



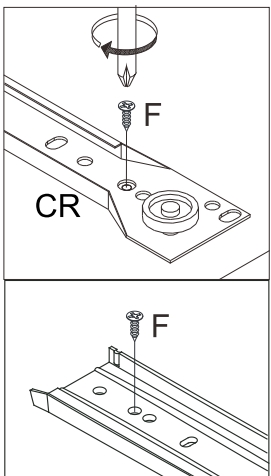
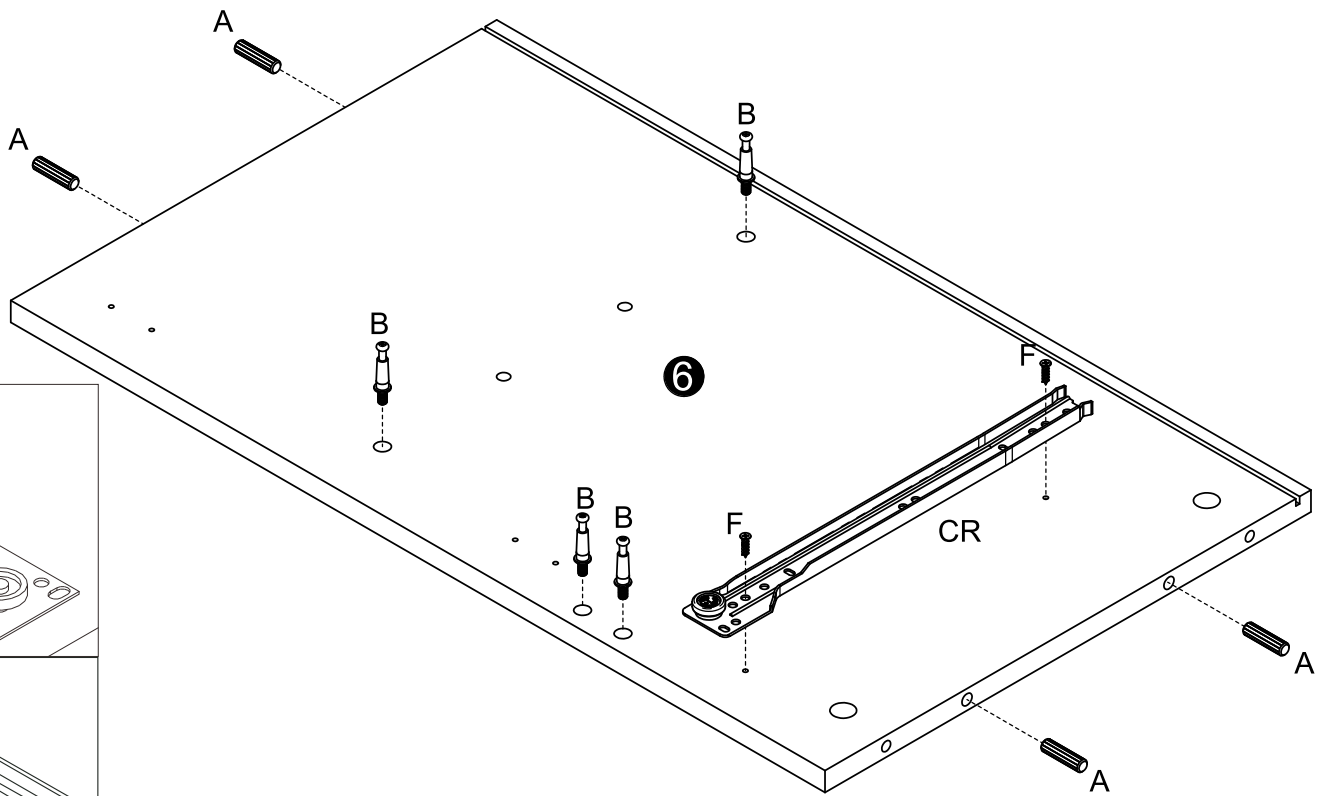
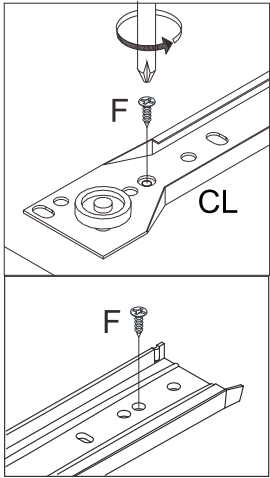
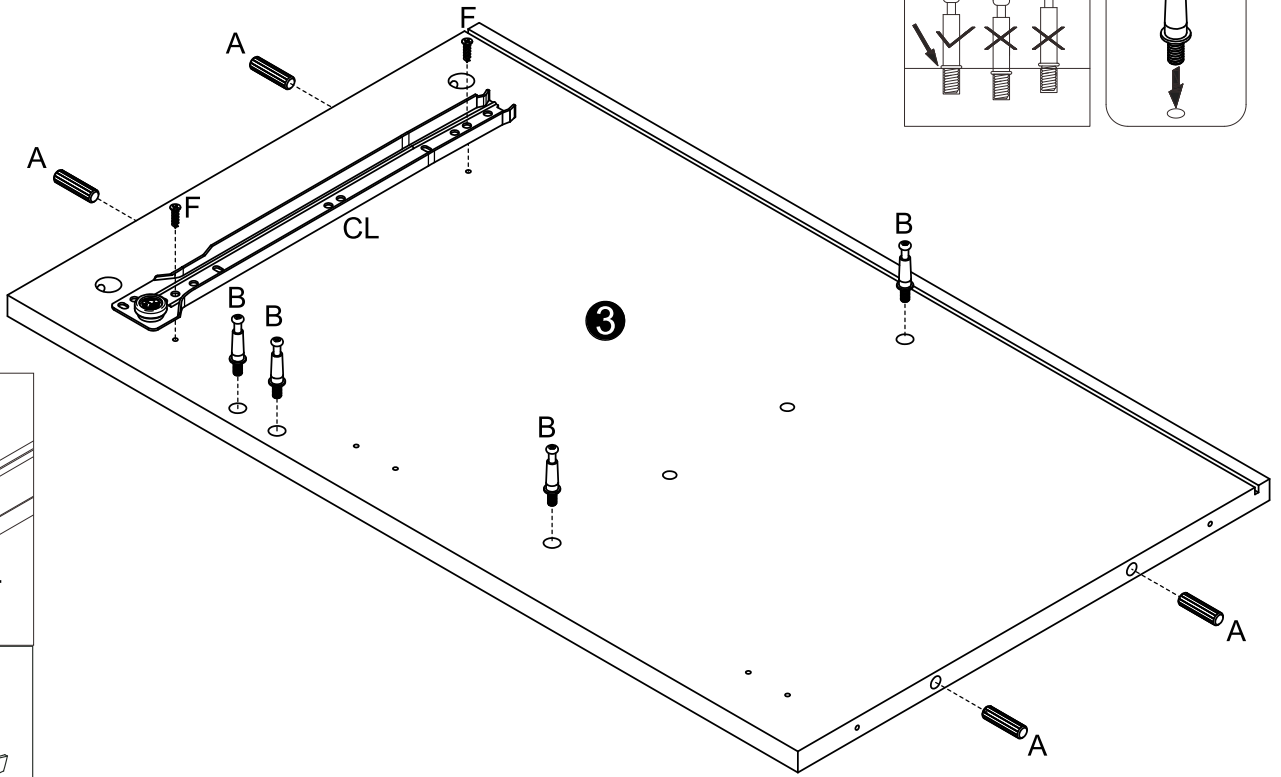
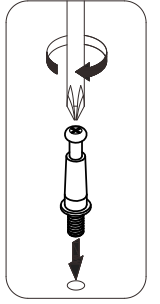
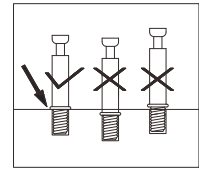

CR

B





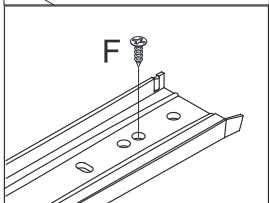
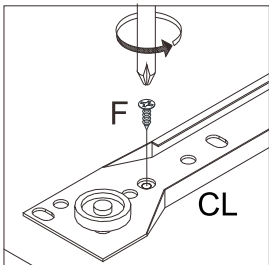
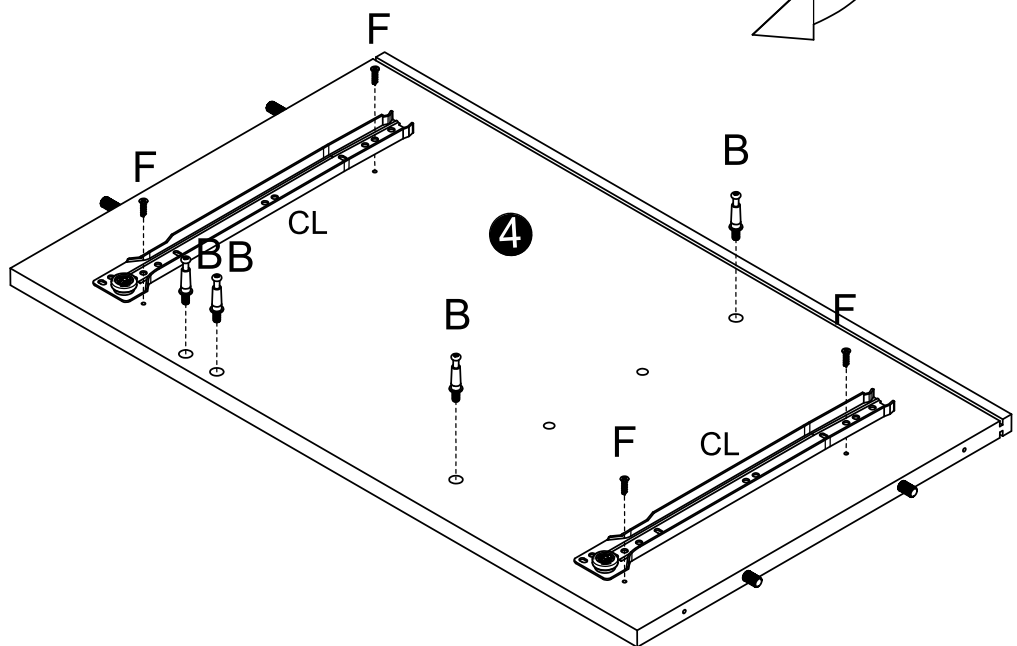
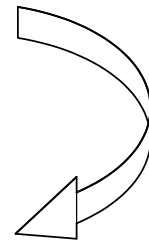
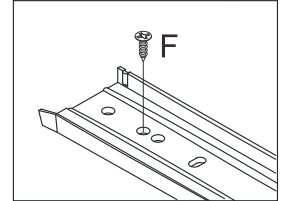
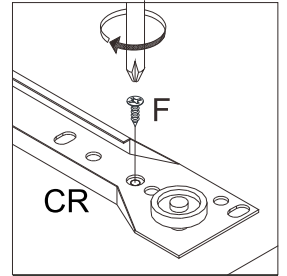
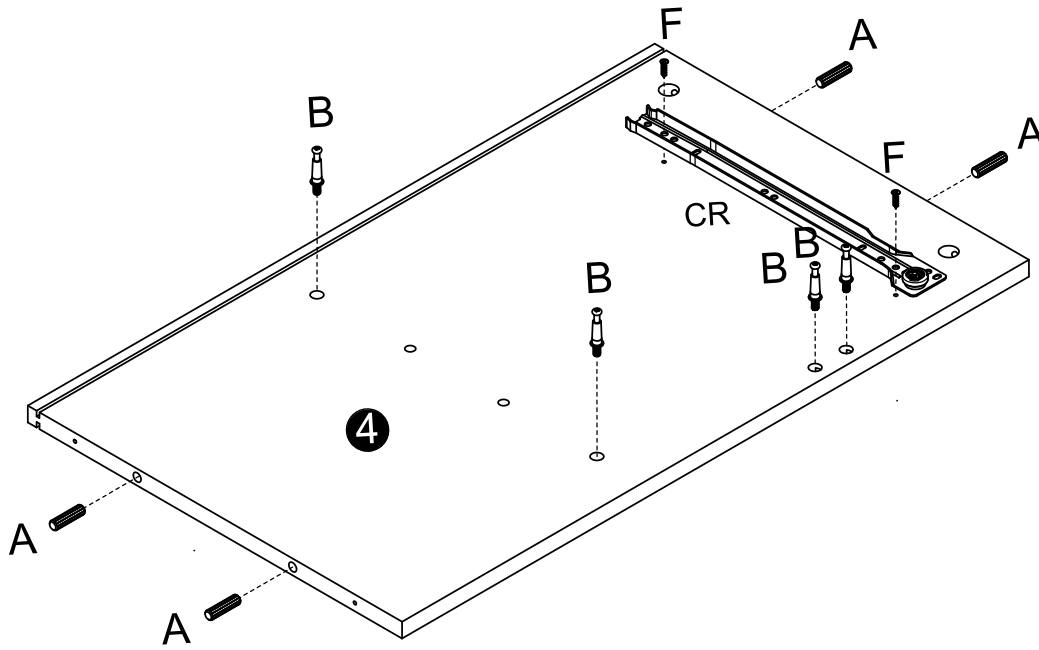
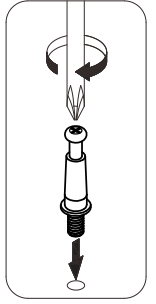
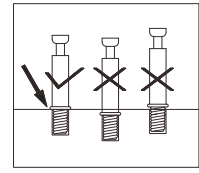

03

Ax4 	Bx8 	G1x2 CL 	G2x1 CR 	Fx6 
$\phi 8 \times 40$				$\phi 3.5 \times 14$

B



04

Ax4 	Bx8 	G1x1 CL 	G2x2 CR 	Fx6 
$\phi 8 \times 40$				$\phi 3.5 \times 14$

B

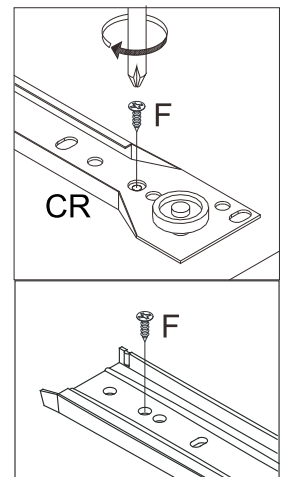
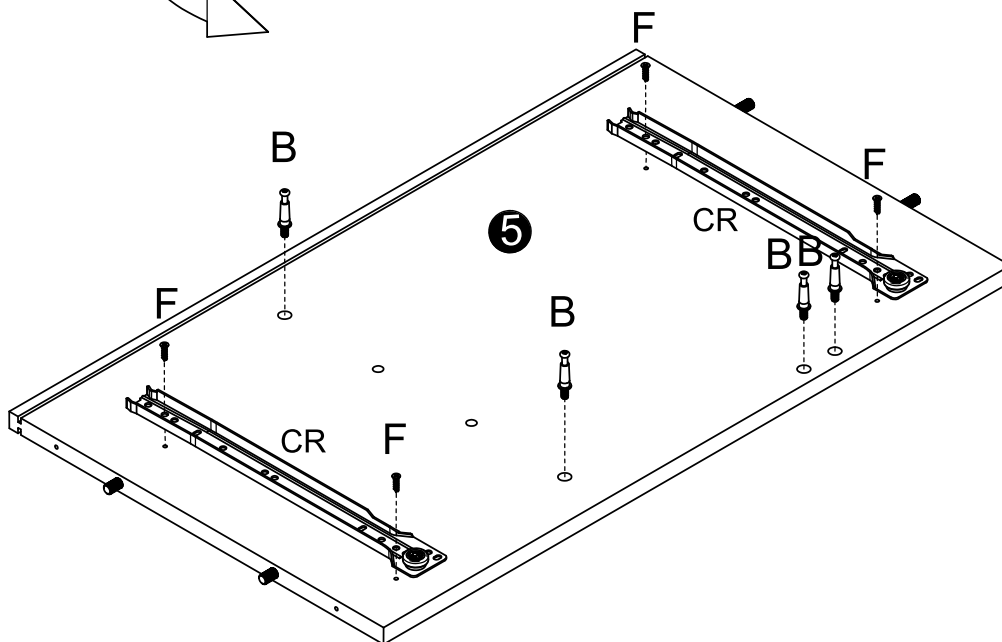
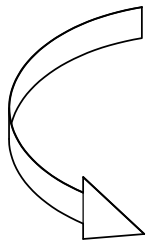
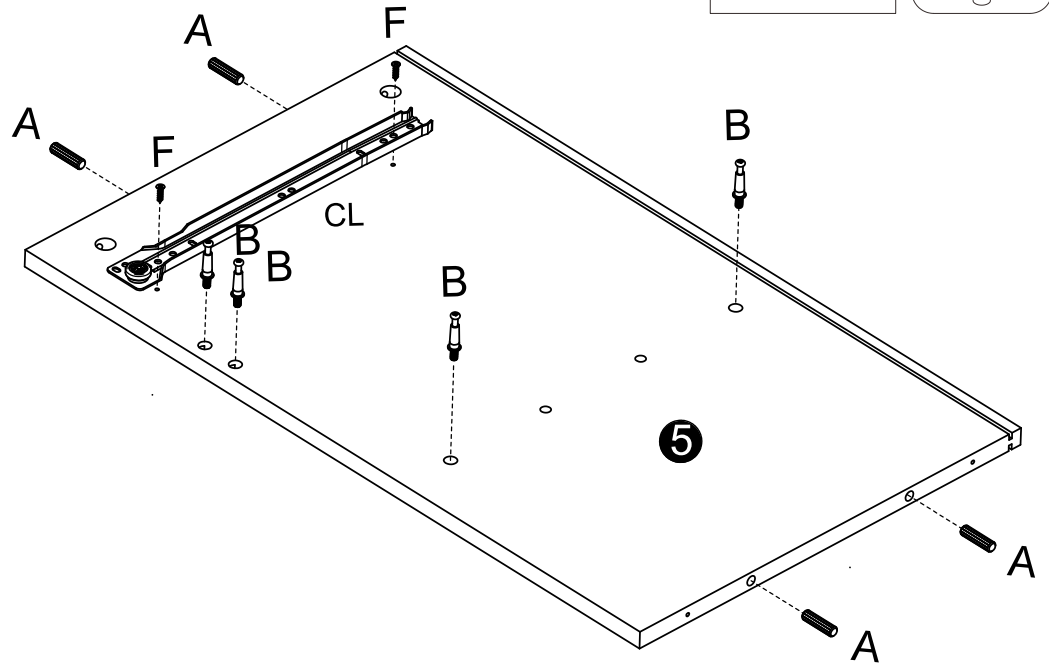
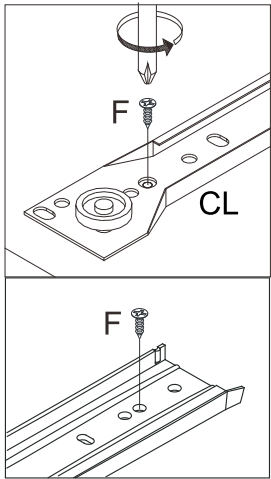
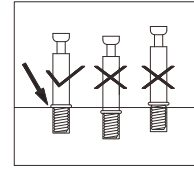
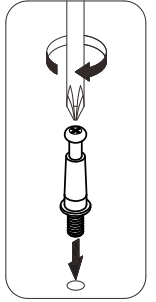

05

Cx16

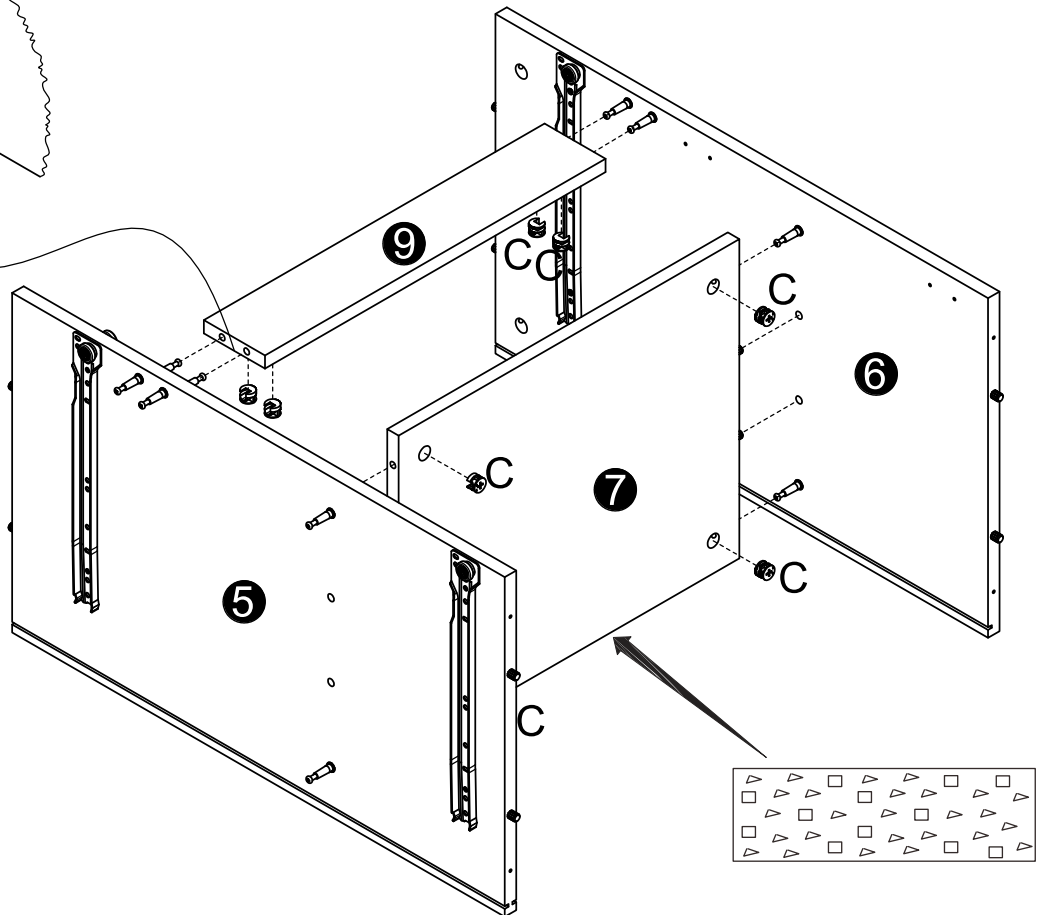
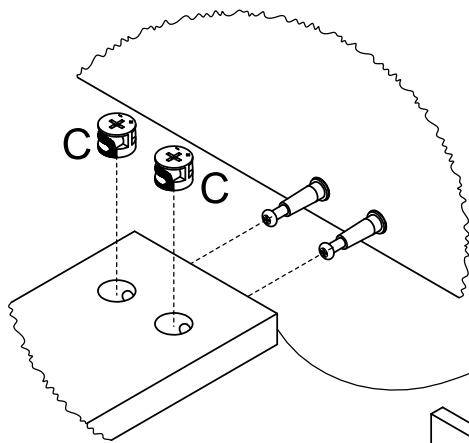
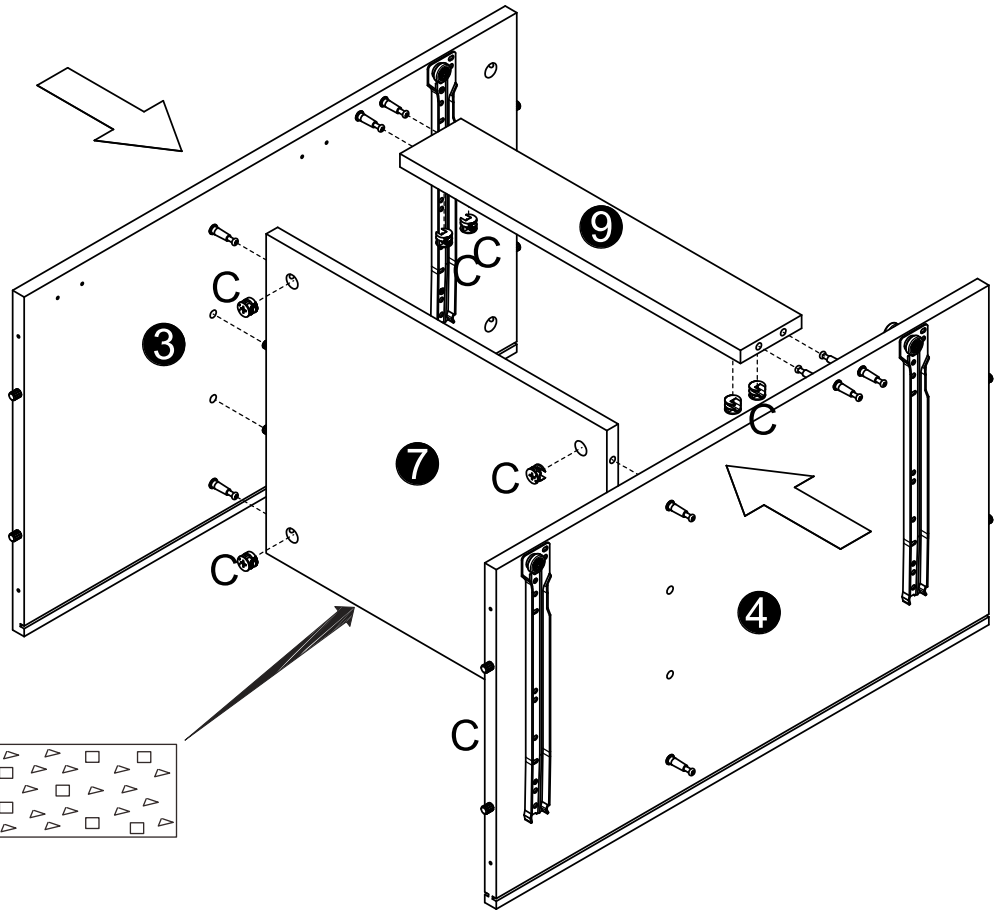

06

Cx8

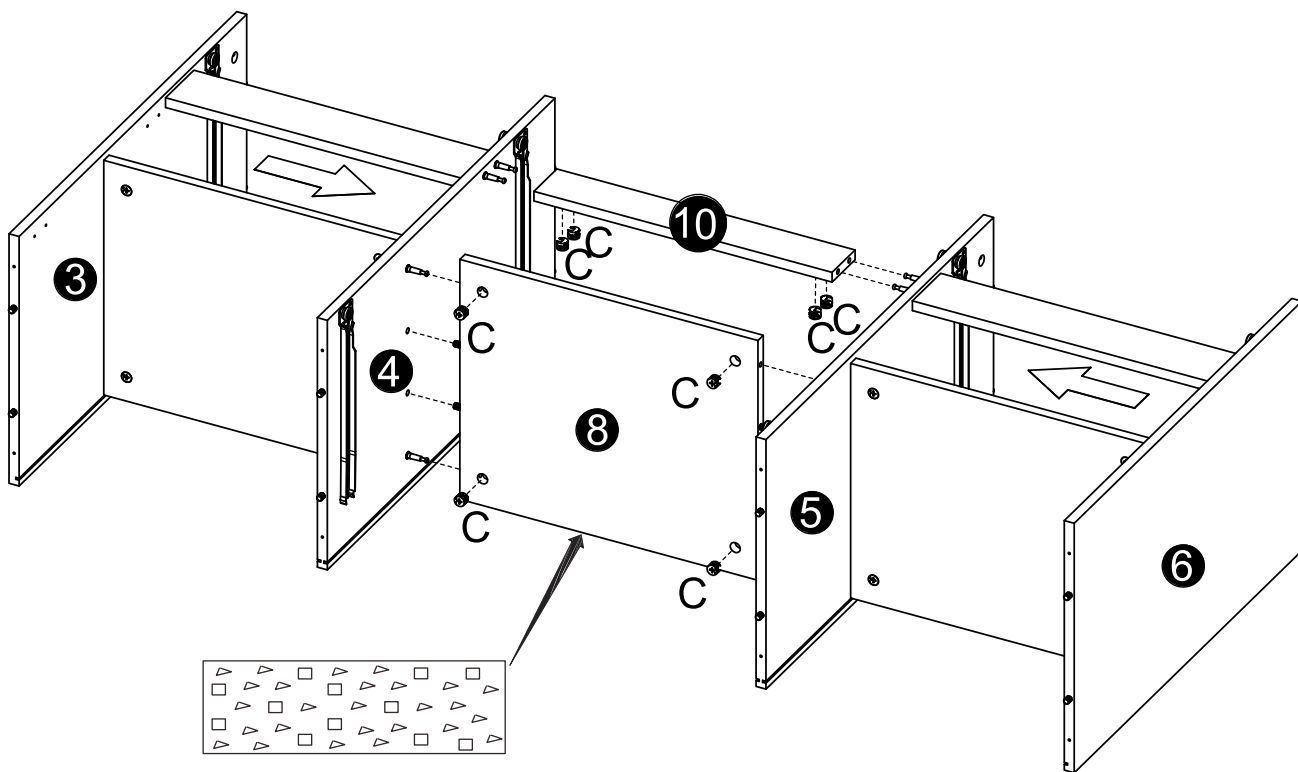

07

Cx8

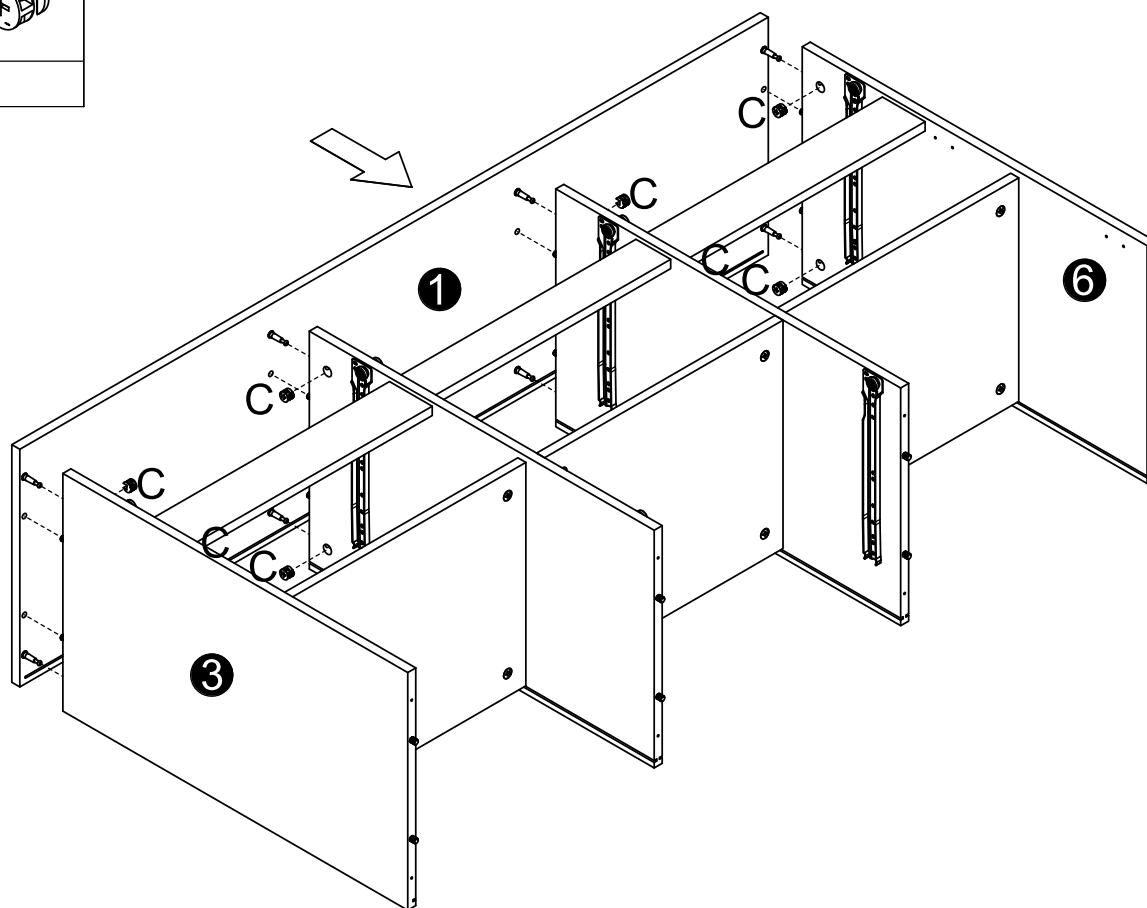

08

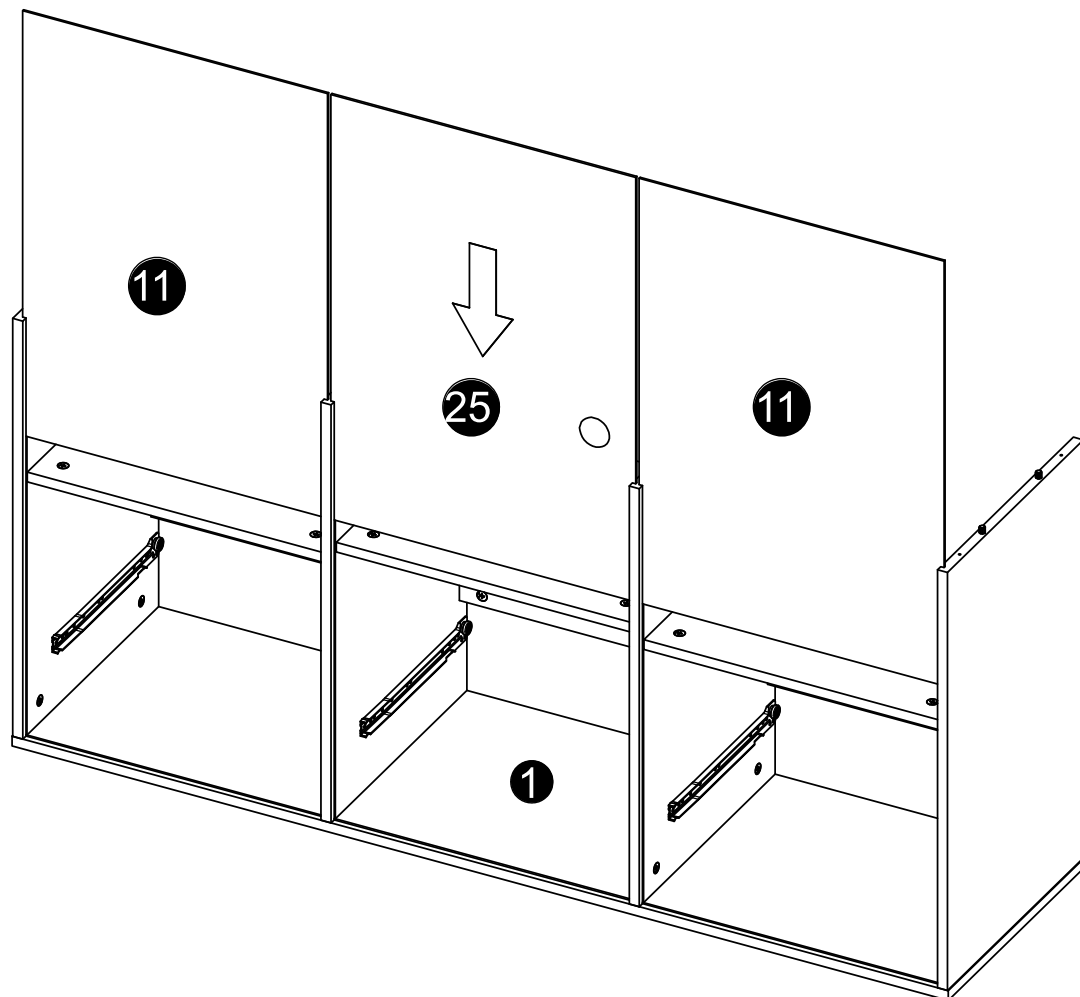

09

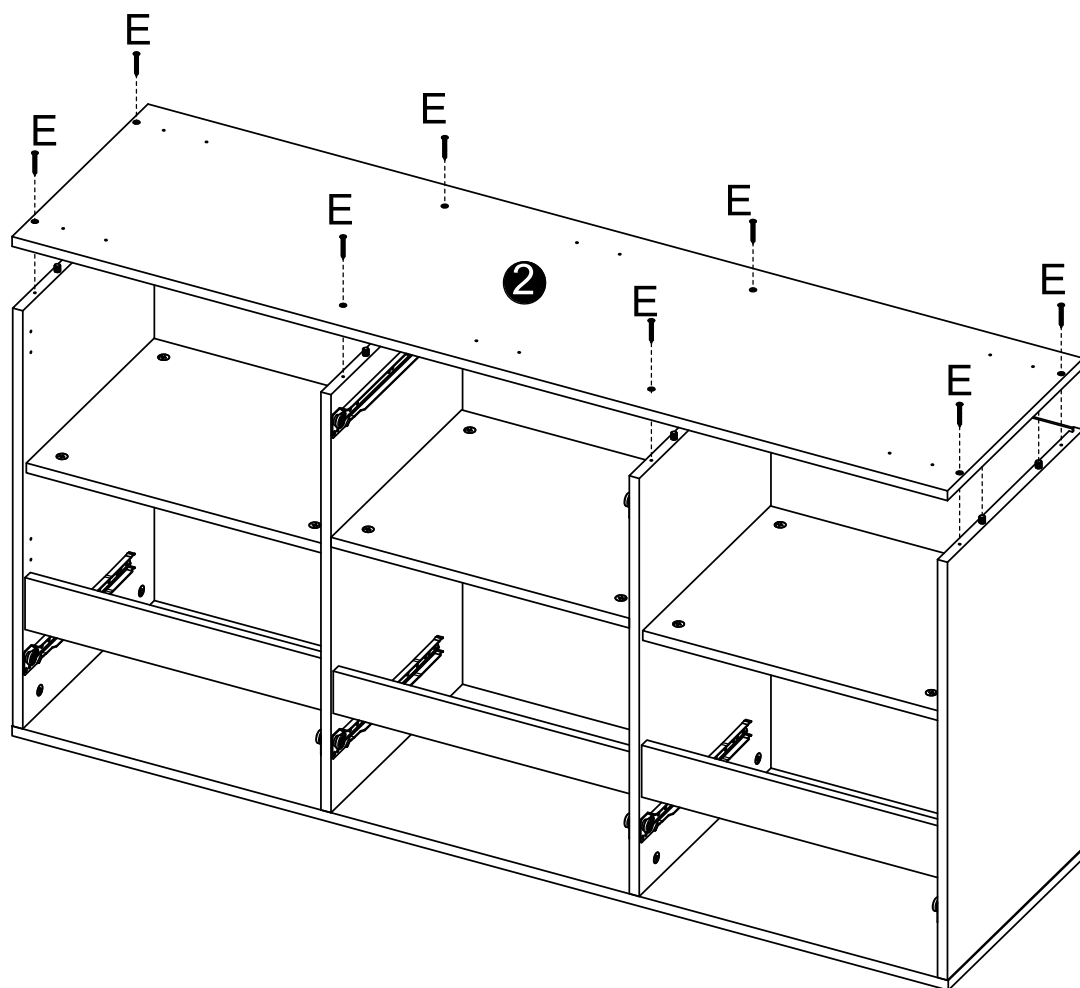
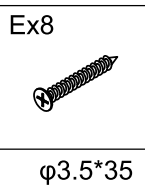

10

Dx12

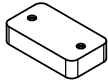
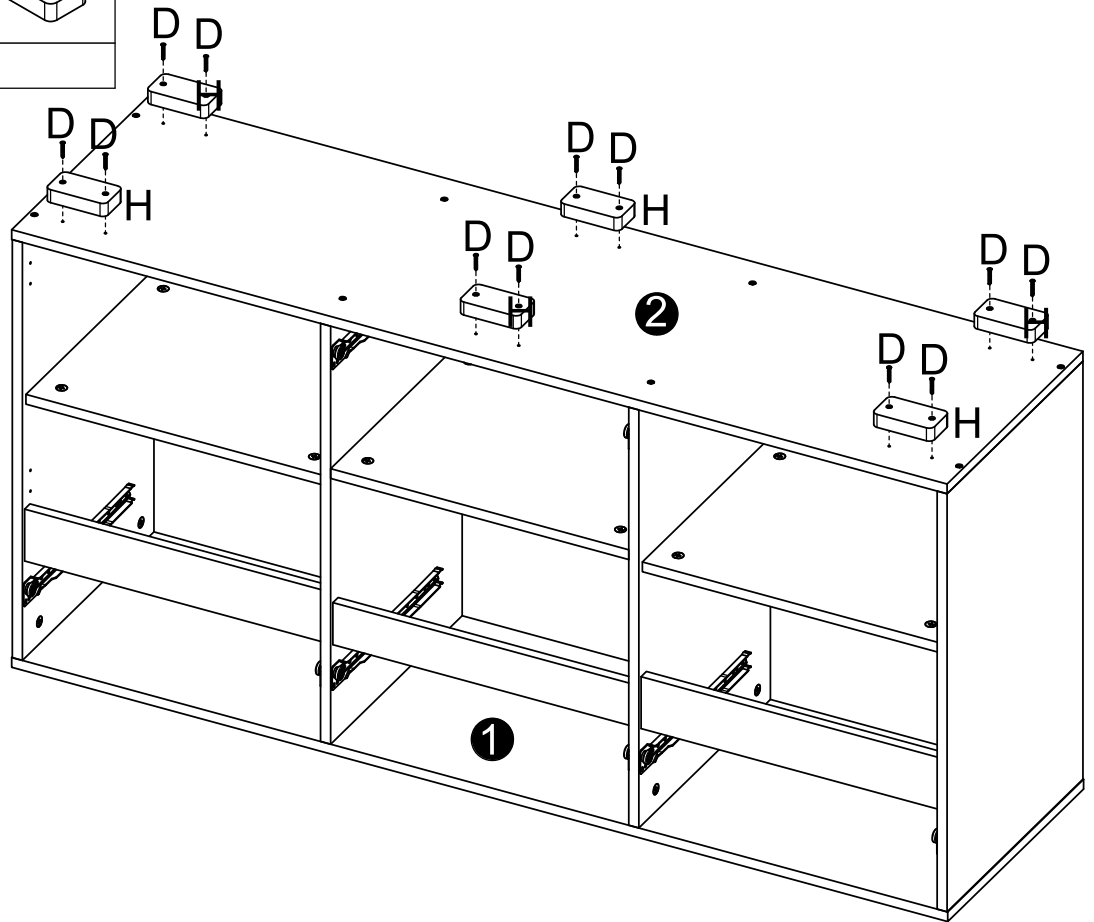

Hx6

 $\phi 4 \times 25$ **11**



F x 8

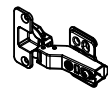
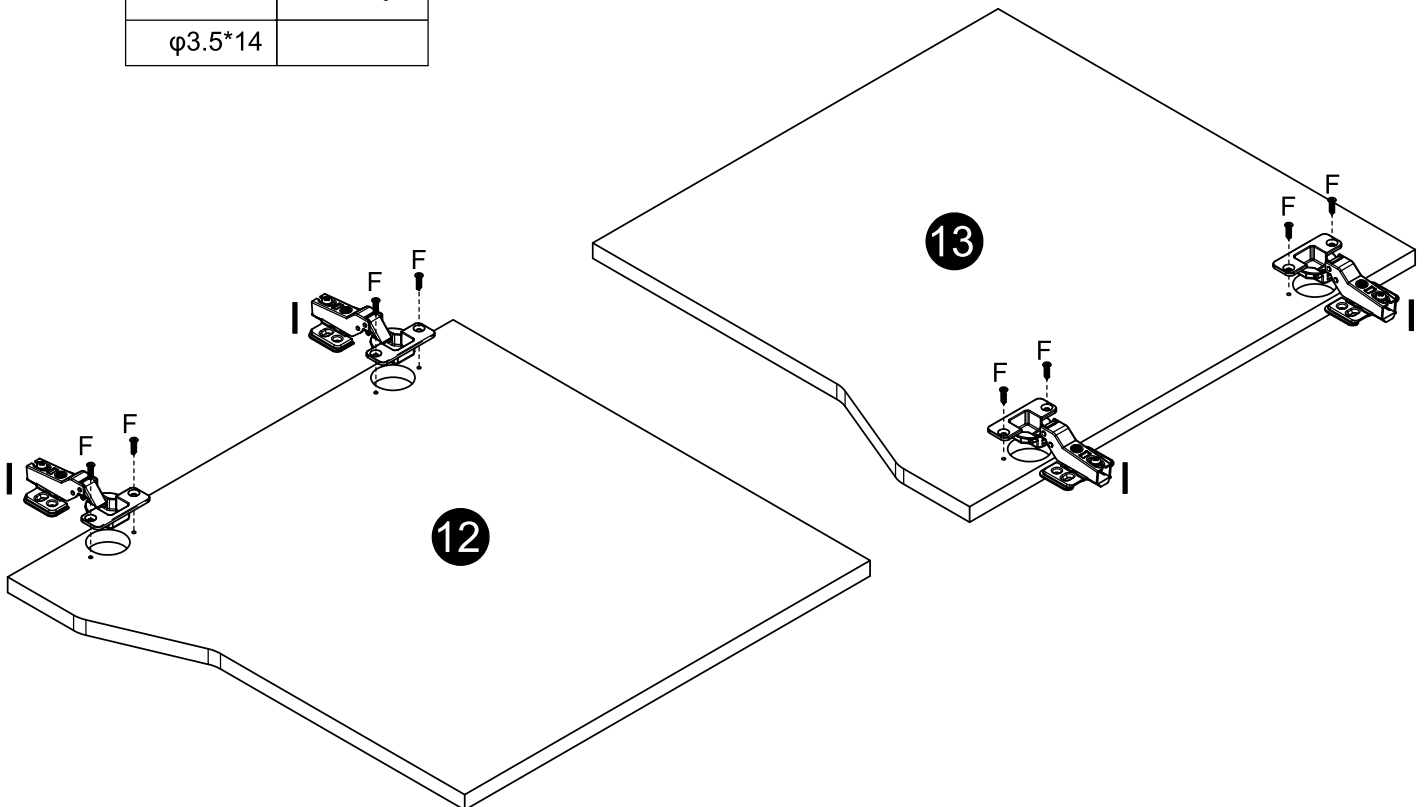

I x 4

 $\phi 3.5 \times 14$ 

12

F x16 	Lx1 
φ3.5*14	

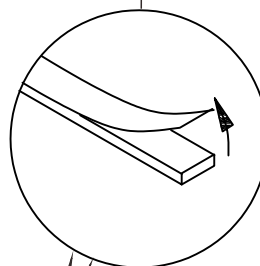
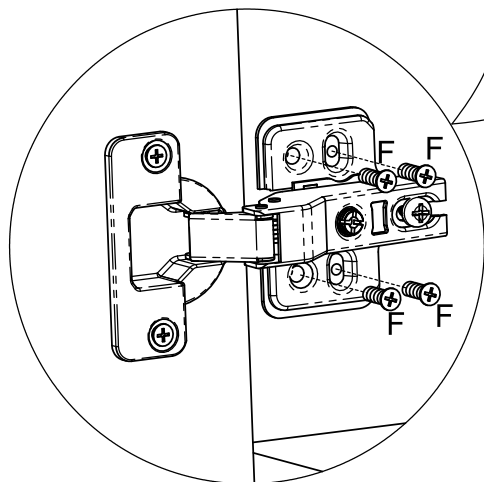
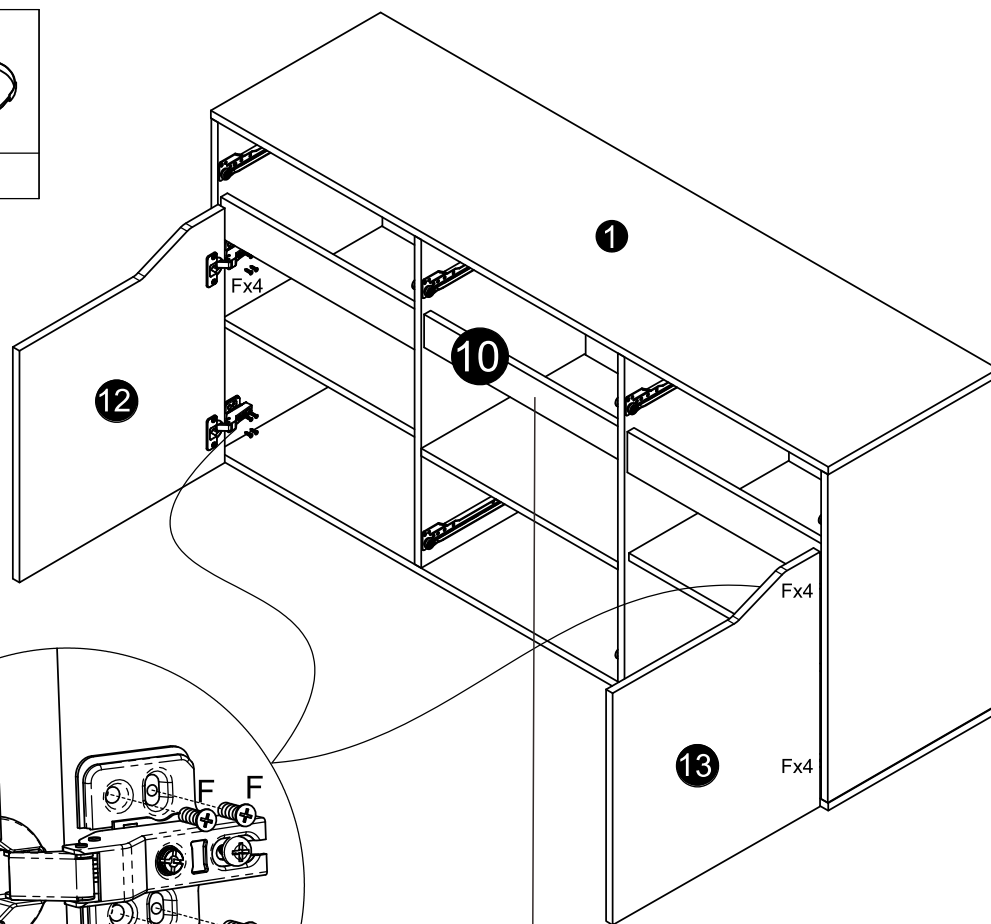



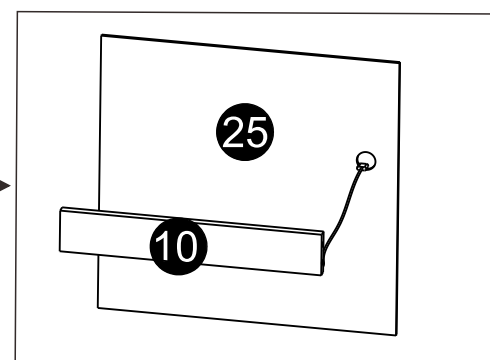
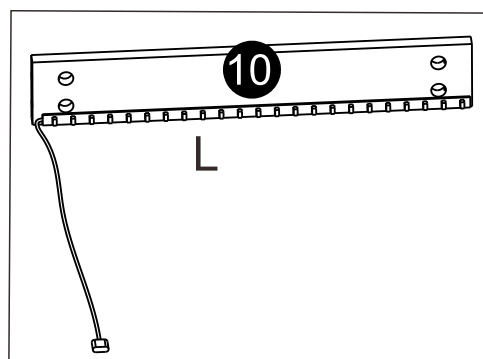

EN: Tear off the back tape
 FR: Déchirer le ruban adhésif arrière
 DE: Reiß das hintere Band ab
 IT: Rimuovere il nastro posteriore
 ES: Arrancar la cinta trasera



DE: Scannen Sie den QR-Code, um die App zur Steuerung des LED-Lichts herunterzuladen.
 EN: Scan the QR code to download the app to control the LED light.
 IT: Scansiona il codice QR per scaricare l'app per controllare la luce LED.
 FR: Scannez le code QR pour télécharger l'application afin de contrôler la lumière LED.
 ES: Escanea el código QR para descargar la aplicación y controlar la luz LED.



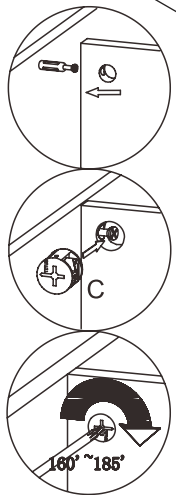
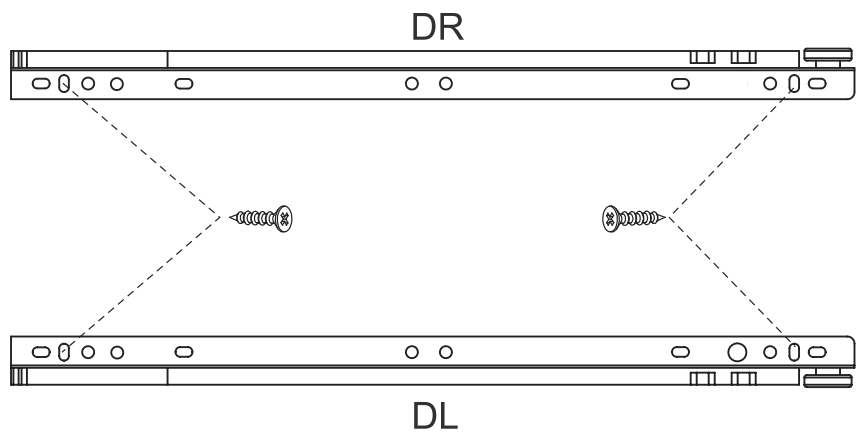
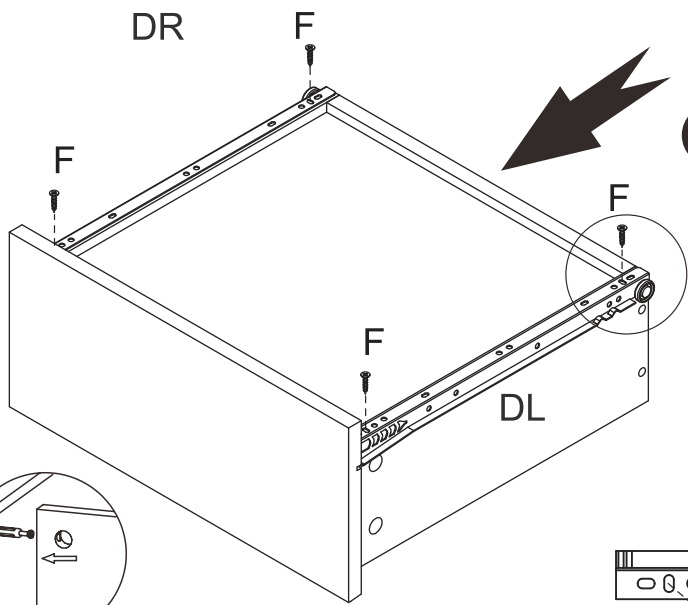
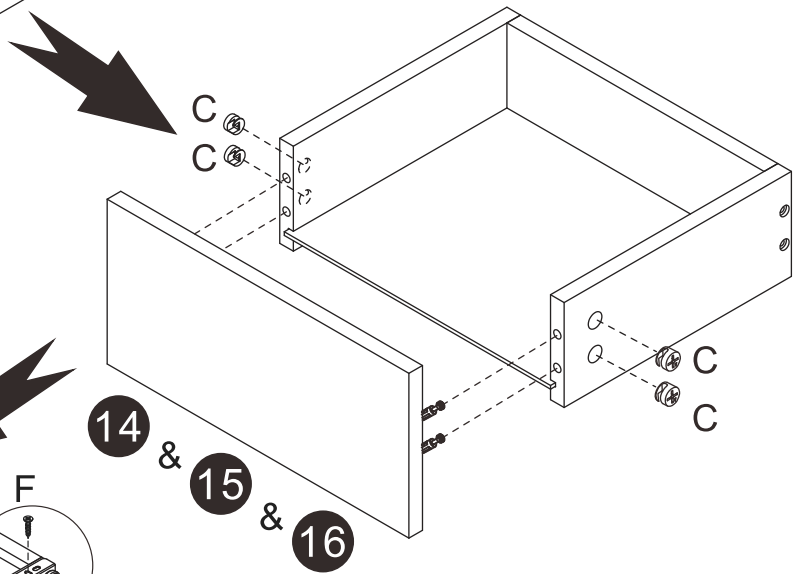
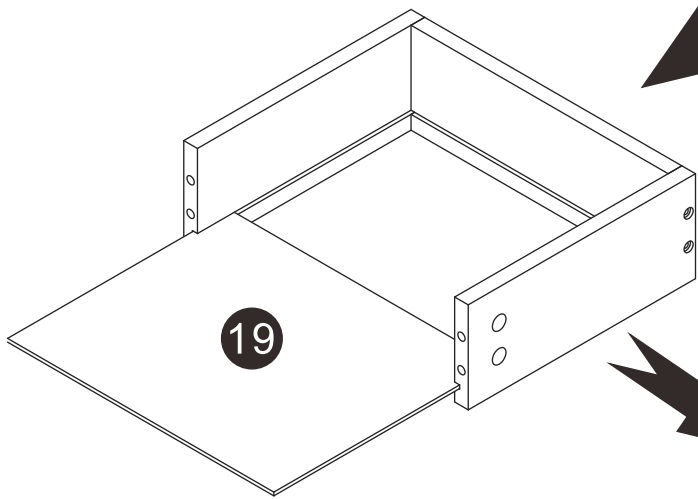
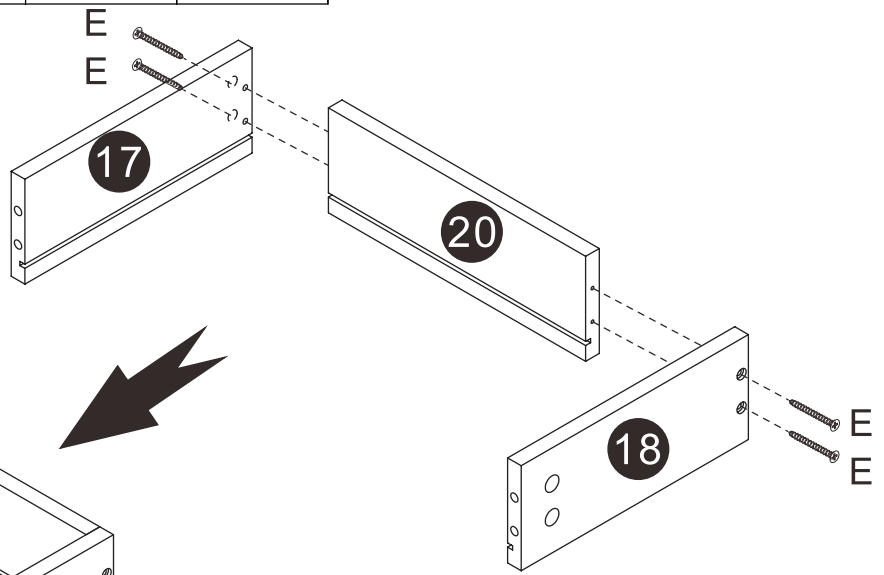

13

Ex12 	Cx12 	G3x3  DL	G4x3  DR	F x12 
φ3.5*35				φ3.5*14



x3

14

Ex4  φ3.5*35	Cx4 	G3x1 DL 	G4x1 DR 	F x4  φ3.5*14
---	--	---	---	--

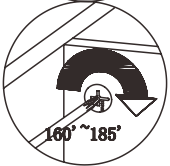
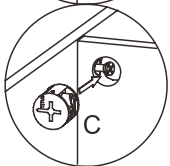
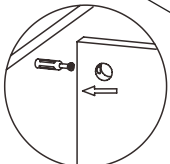
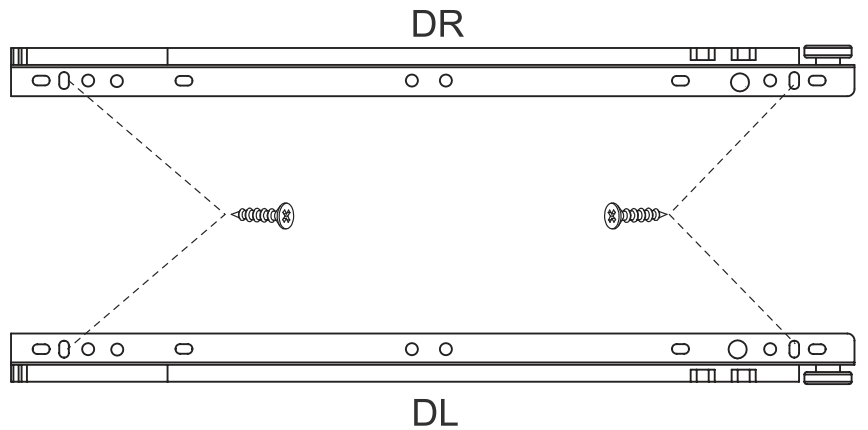
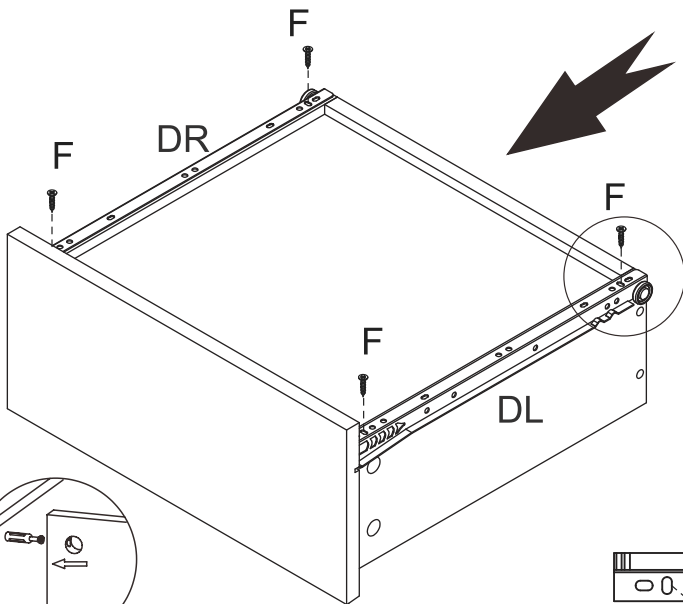
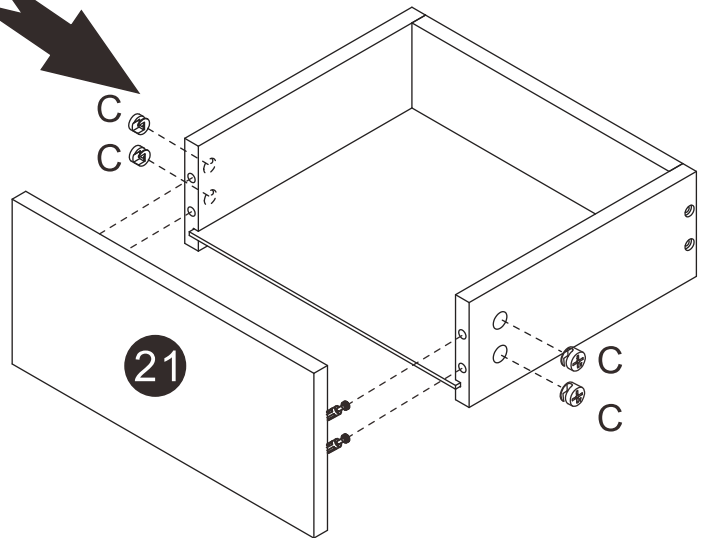
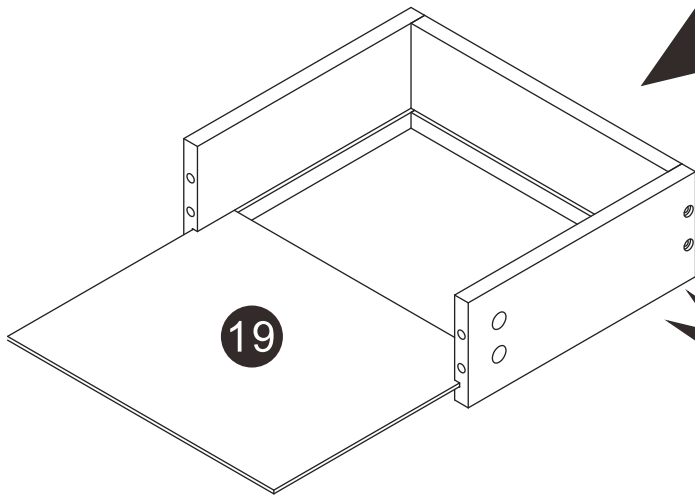
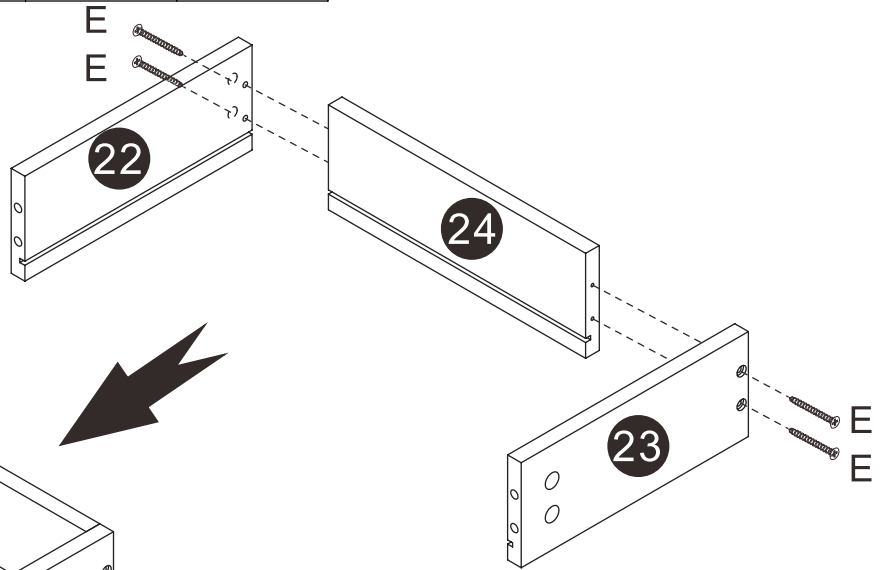

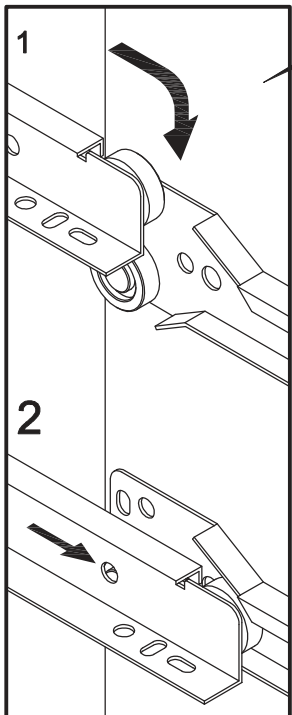
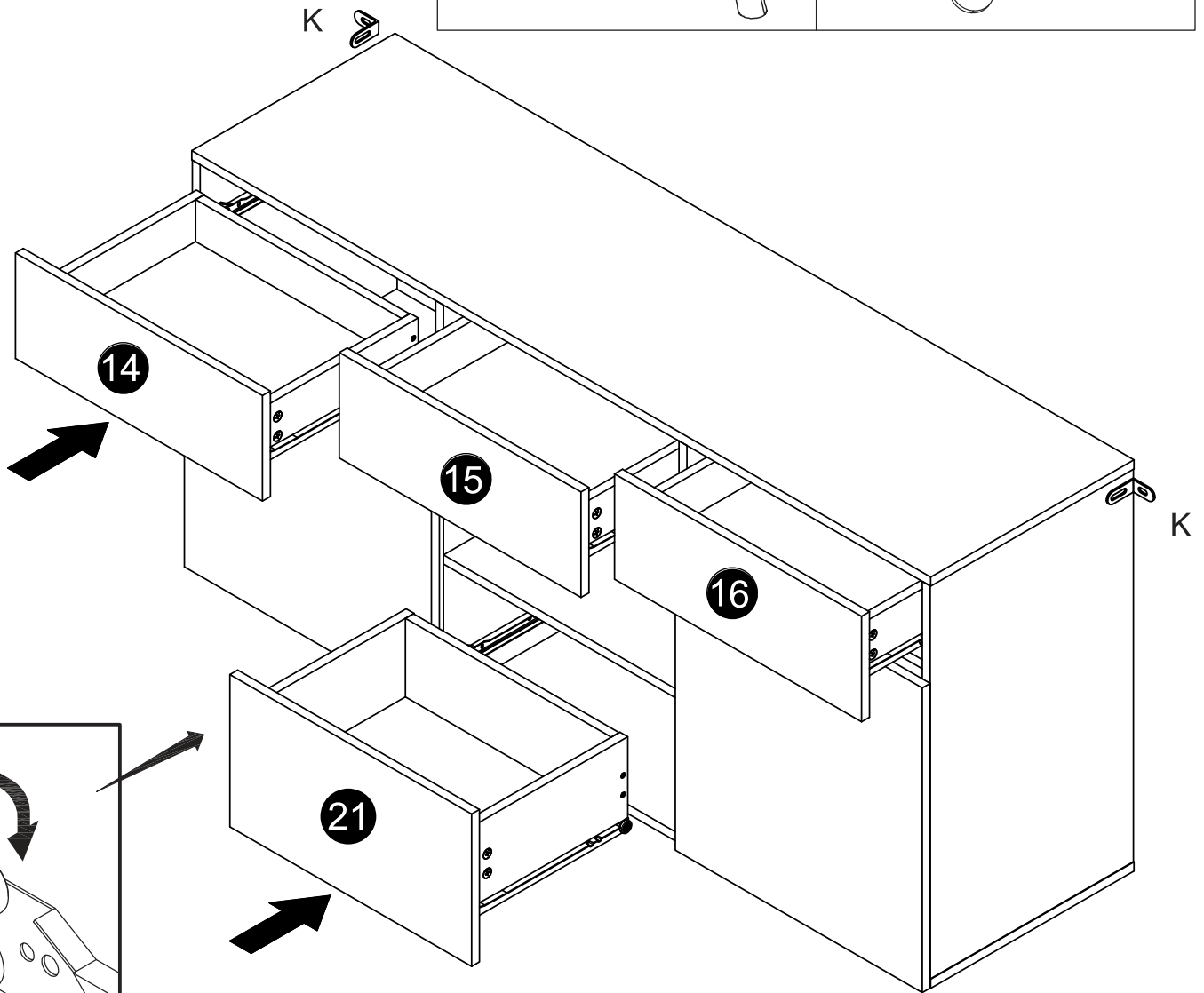
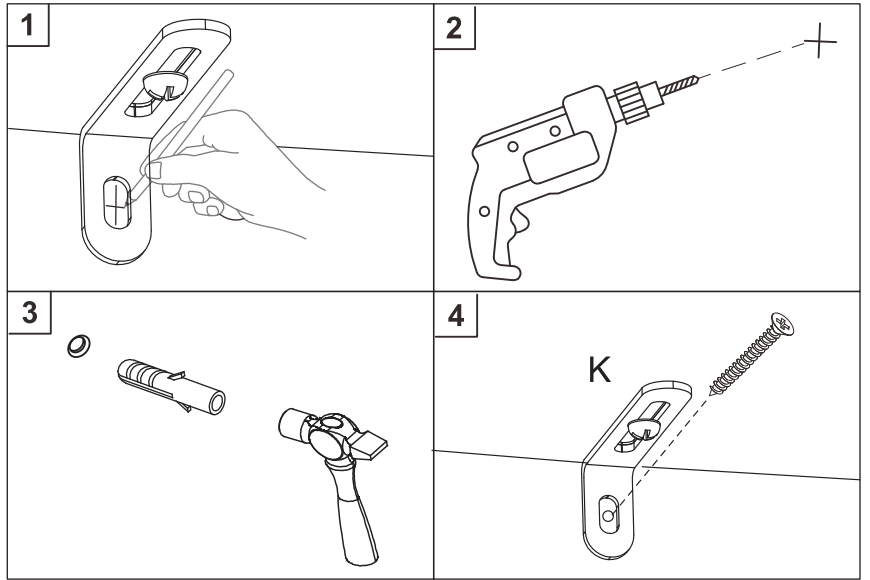
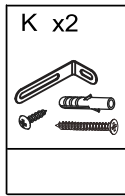

180° ~ 185°

15



16

Mx12 	Nx12 
$\phi 3.5 \times 14$	

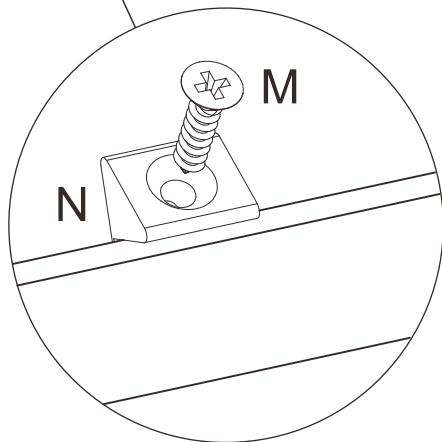
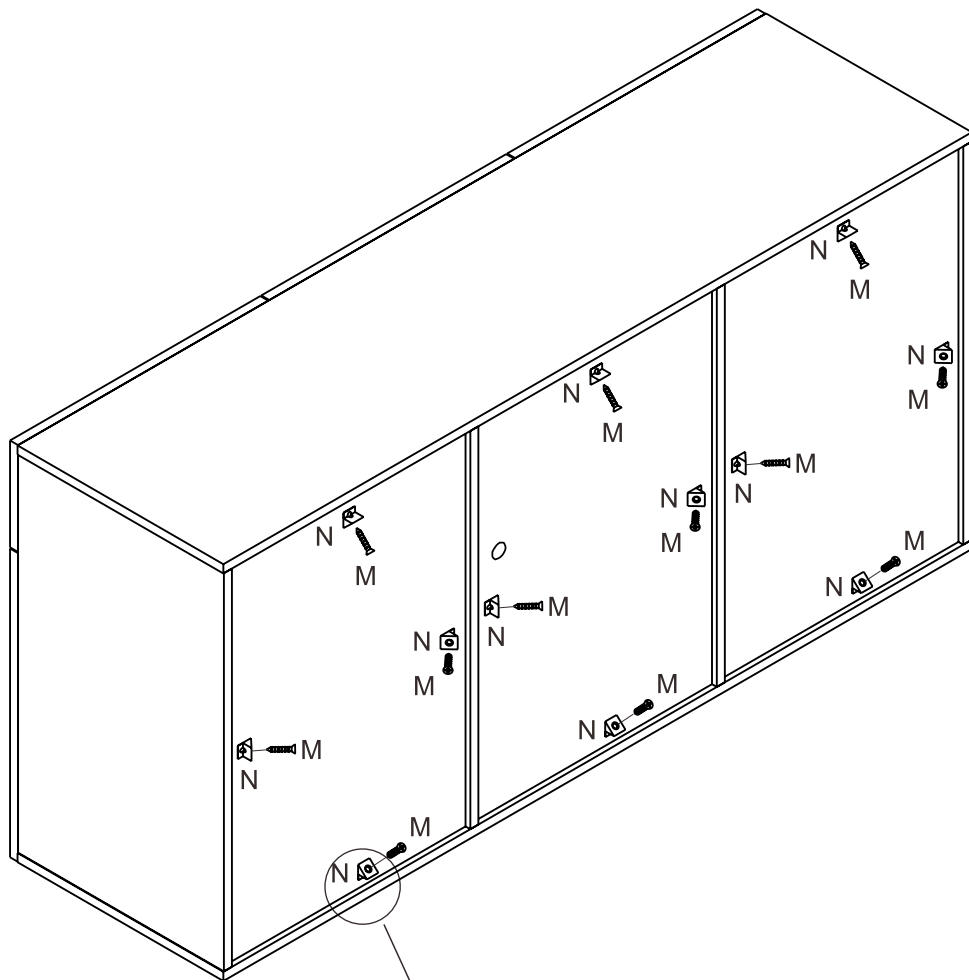

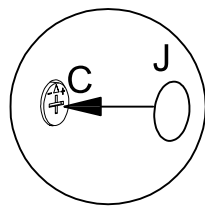
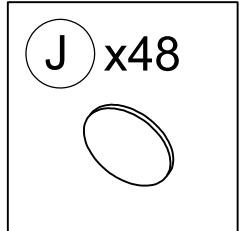
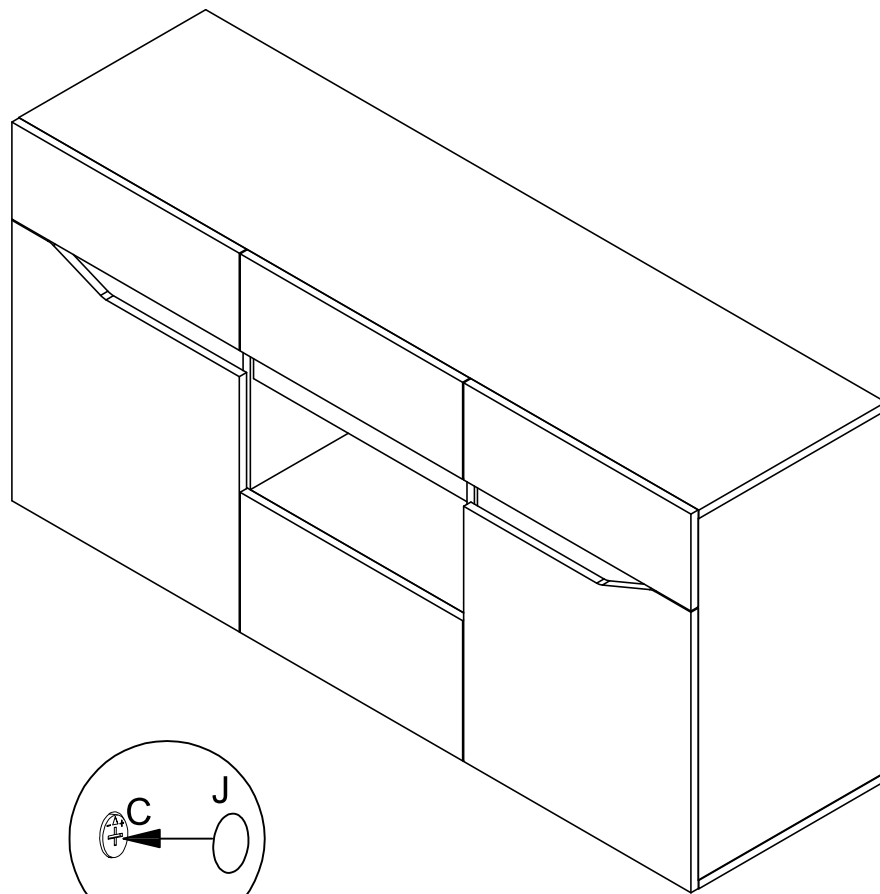

UK: After installing the product, stick the number J on the perforated position

FR: Une fois le produit installé, collez le numéro J à l'endroit où il y a des trous

DE: Nach der Installation des Produkts kleben Sie die Nummer J auf die perforierte Position

IT:Dopo l'installazione del prodotto, fissare il numero J sulla posizione perforata

ES:Después de instalar el producto, pegue el número J en la posición perforada

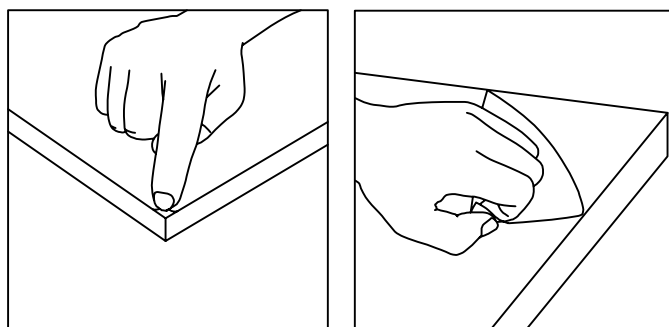

[DE]

BITTE BEACHTEN: Teilenummer 12.13.14.15.16.21 ist mit einer dichten Kunststoffschutzfolie überzogen. Wenn das Produkt nach der Demontage Kratzer aufweist, machen Sie sich bitte keine Sorgen, es handelt sich nicht um einen Produktschaden. Bitte ziehen Sie die schützende Kunststoffolie langsam entlang der Kante von der Oberfläche ab. Nach dem Abziehen wird das Produkt glatt und sauber.

[EN]

PLEASE NOTE: Part number 12.13.14.15.16.21 are covered with a tight plastic protective film. If there are scratches on the product after disassembly, please don't worry, it's not product damage. Please slowly tear off the protective plastic film on the surface along the edge. After peeling off, the product becomes smooth and clean.

[FR]

REMARQUE : les pièces numéro 12.13.14.15.16.21 sont recouvertes d'un film protecteur en plastique étanche. Si le produit présente des rayures après le démontage, ne vous inquiétez pas, il ne s'agit pas d'un dommage au produit. Retirez lentement le film protecteur en plastique sur la surface le long du bord. Une fois décollé, le produit devient lisse et propre.

[IT]

NOTA BENE: il numero di parte 12.13.14.15.16.21 è coperto da una pellicola protettiva in plastica stretta. Se ci sono graffi sul prodotto dopo lo smontaggio, non preoccuparti, non è un danno al prodotto. Strappare lentamente la pellicola protettiva in plastica sulla superficie lungo il bordo. Dopo averla staccata, il prodotto diventa liscio e pulito.

[ES]

NOTA: La pieza número 12.13.14.15.16.21 está cubierta con una película protectora de plástico. Si hay rayones en el producto después de desmontarlo, no se preocupe, no se trata de daños en el producto. Retire lentamente la película protectora de plástico de la superficie a lo largo del borde. Después de despegarla, el producto quedará liso y limpio.

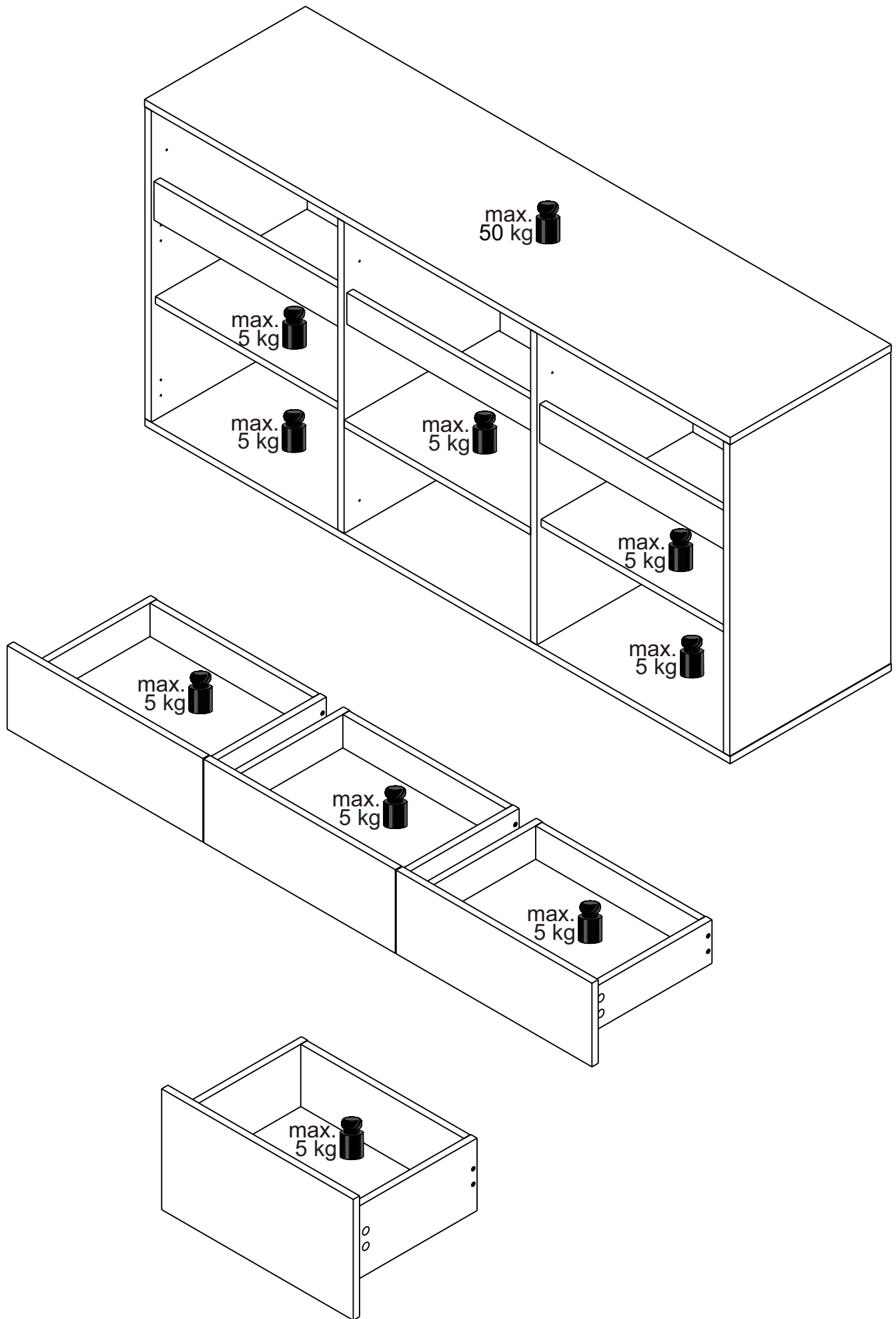

APP-PROGRAMMANWENDUNG



HINWEIS:

Detaillierte Anleitung im Menü "Guide"

PRODUKTPARAMETER

- Bluetooth: BLEVA 2
- Eingangsspannung: 4.5~26V
- Betriebstemperatur: -25~75 °C
- Abmessungen: 43×22×11 mm
- Gewicht: 30g
- Max. Leistung: 144W (24V)

VERBINDUNGSSCHRITTE

- ① LED-Farbstreifen & Controller verbinden, Controller einschalten
- ② QR-Code scannen zum App-Download:



- ③ App starten, Controller suchen & verbinden
- ④ Bluetooth-Drahtlossteuerung genießen

PRODUKTMERKMALE

- Direkte Handy-Steuerung (20m Reichweite)
- Automatische Verbindung in 5 Sekunden
- Musikrhythmus-Synchronisation
- Gruppensteuerung
- Helligkeits-/Geschwindigkeitsregelung
- Unterstützt bis 10m RGB(W)-Streifen
- Automatische Sprachumschaltung (DE/EN)

ANIMATIONSEFFEKTE

- Farbverläufe
- Einfarbige/ Zweifarbige Gradienten
- Monochrome/Bunte Blinkereffekte
- Farbspringen
- Musikresponsive Effekte

APP PROGRAM USAGE



Scan two-dimensional code download APP

①Connect LED color strip and controller, power on controller

②Scan two-dimensional code download APP:



③Start APP, search and connect controller

④Enjoy the Bluetooth wireless control experience



Notes:

detailed operating instructions, enter the menu "Guide":

Product Parameters:

- Bluetooth:BLEV4.2
- Input Voltage:4.5~26V
- Working Temp:-25~75°C
- Size:43*22*11mm
- Weight:30g
- Max Power:144W(24V)

LED mobile phone Bluetooth controllerProduct Features

- LED Bluetooth controller is directly via mobilephone control remote distance can reach 20m without the need to setupeasy to connect open the software within 5 seconds you can automatically connect the controller
- Flow the rhythm of the music changes
- Group control
- Brightness,speed addition and subtraction
- Maximum can be 10 meters RGB(W)strip

-The software shows that the text is based onthe language of the mobile phone set up automatic transformation of Chinese and English

ANIMATION EFFECTS:

- Colorful gradient
- All kinds of monochrome,double color gradient
- All kinds of monochrome,double color,colorfull flashing
- Colorful jump
- Follow the thythm of the music chagnes

APP-PROGRAMMANWENDUNG

Afficher la
liste des lampes
Farbrad
Changer la
Roue chromatique

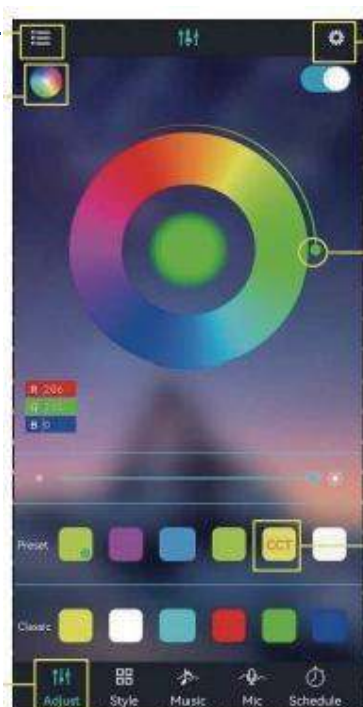

Afficher les
paramètres

Ajuster la couleur

Cliquez sur l'icône
carrée pour ajuster
la couleur.

Changer d'
interface
par clic



REMARQUE :

Guide détaillé dans le menu
"Guide"

CARACTÉRISTIQUES

- Bluetooth : BLEVA 2
- Tension d'entrée : 4.5~26V
- Température : -25~75° C
- Dimensions : 43×22×11 mm
- Poids : 30g
- Puissance max : 144W (24V)

ÉTAPES DE CONNEXION

- ① Connecter bande LED & contrôleur, allumer
- ② Scanner QR code pour télécharger l'app :



- ③ Lancer l'app, rechercher & connecter
- ④ Profiter du contrôle Bluetooth sans fil

FONCTIONNALITÉS

- Contrôle direct par smartphone (20m)
- Connexion automatique en 5 secondes
- Synchronisation musicale
- Contrôle de groupe
- Réglage luminosité/vitesse
- Prise en charge bandes $\leq 10m$ RGB(W)
- Basculage automatique FR/EN

EFFETS D'ANIMATION

- Dégradés de couleurs
- Dégradés uni/bicolores
- Clignotements mono/colorés
- Saut de couleurs
- Effets réactifs à la musique

UTILIZZO APP



PASSI CONNESSIONE

- ① Collega striscia LED & controller, accendi
- ② Scansiona QR code per scaricare APP:



- ③ Avvia APP, cerca & connetti controller
- ④ Goditi controllo wireless Bluetooth



NOTA:

Guida completa nel menu "Guide"

SPECIFICHE:

- Bluetooth: BLEVA 2
- Tensione ingresso: 4.5~26V
- Temperatura: -25~75° C
- Dimensioni: 43×22×11 mm
- Peso: 30g
- Potenza max: 144W (24V)

CARATTERISTICHE

- Controllo diretto smartphone (20m)
- Connessione automatica in 5 secondi
- Sincronizzazione ritmo musicale
- Controllo di gruppo
- Regolazione luminosità/velocità
- Supporto strisce ≤10m RGB(W)
- Auto switch IT/EN

EFFETTI ANIMAZIONE:

- Sfumature colore
- Gradienti mono/bicolori
- Luci lampeggianti mono/colorate
- Salto colori
- Effetti reattivi alla musica

USO DE LA APLICACIÓN



PASOS DE CONEXIÓN

- ① Conectar tira LED y controlador, encender
- ② Escanear QR para descargar APP:



- ③ Iniciar APP, buscar y conectar
- ④ Disfrutar control inalámbrico Bluetooth



NOTA:

Guía completa en menú "Guide"

ESPECIFICACIONES:

- Bluetooth: BLEVA 2
- Voltaje entrada: 4.5~26V
- Temperatura: -25~75° C
- Tamaño: 43×22×11 mm
- Peso: 30g
- Potencia máx: 144W (24V)

CARACTERÍSTICAS

- Control directo móvil (20m alcance)
- Conexión automática en 5 segundos
- Sincronización ritmo musical
- Control grupal
- Ajuste brillo/velocidad
- Soporte tiras ≤10m RGB(W)
- Auto cambio ES/EN

EFFECTOS DE ANIMACIÓN:

- Degradados de color
- Transiciones mono/bicolores
- Destellos monocromáticos/color
- Salto de colores
- Efectos reactivos a música



Certificate of Compliance

Certificate Number: ZHT-250114113C01C

Applicant Name / Zertifikatsinhaber : Shenzhen Dengdai Yunlian Lighting Co., Ltd
Address / Adresse : 2nd Floor, Building A, No. 15 Jinkui East Road, Kuiyong Street, Dapeng New District, Shenzhen, Guangdong, China
Manufacturer / Hersteller : Shenzhen Dengdai Yunlian Lighting Co., Ltd
Address / Adresse : 2nd Floor, Building A, No. 15 Jinkui East Road, Kuiyong Street, Dapeng New District, Shenzhen, Guangdong, China
Product / Produkt : CCT led strips
Main Model(s) / Hauptmodell(e) : 2835 CCT-05
Additional Model(s) / Zusätzliche(s) Modell(e) : 2835 CCT-03, 2835 CCT-12, 2835 CCT-24
Trade Mark / Warenzeichen : 
Test Standard / Geprüft nach : IEC 62321-3-1:2013, IEC 62321-4:2013+A1:2017, IEC 62321-5:2013, IEC 62321-6:2015, IEC 62321-7-1:2015, IEC 62321-7-2:2017, IEC 62321-8:2017
Test Report No./Bericht Nr : ZHT-250114113C01

The EUT described above has been consolidated by us and found in compliance with the council RoHS Directive 2011/65/EU Annex II amending Annex (EU)2015/863. It is possible to use CE marking to demonstrate the compliance with this RoHS Directive. It is only valid in connection with the test report.

After preparation of the necessary technical documentation according the requirement of EN IEC63000:2018 as well as the verification of conformity the CE marking as shown below can be affixed on the equipment.



The information of the certificate can be checked through www.zht-lab.cn.
The CE mark which is shown on the certificate can only be used under the conditions that the products complete with all of the relevant Directives of EC Declaration of Conformity.
The Manufacturer should be responsible for the internal production control so that the products complied with the essential requirements of the above mentioned Directive(s). Certificate holder must notify all changes to the original certification laboratory of Guangdong Zhonghan Testing Technology Co., Ltd.



Guangdong Zhonghan Testing Technology Co., Ltd.
Address: Room 104/201, Building 1, Yibaolai Industrial Park, Qiaotou, Fuhai Subdistrict, Bao'an District, Shenzhen, Guangdong, China
Tel.: +86-755-27782934 **Http://**www.zht-lab.cn **E-mail:** admin@zht-lab.cn



Certificate of Compliance

Certificate Number: ZHT-251124124E01C

Certificate's Holder : Shenzhen Dengdai Yunlian Lighting Co., Ltd
Zertifikatsinhaber : 2nd Floor, Building A, No. 15 Jinkui East Road, Kuiyong Street,
DapengNew District, Shenzhen, Guangdong, China

Manufacturer : Shenzhen Dengdai Yunlian Lighting Co., Ltd
Hersteller : 2nd Floor, Building A, No. 15 Jinkui East Road, Kuiyong Street,
DapengNew District, Shenzhen, Guangdong, China

Trade Mark : VITO
Warenzeichen

Product : LED light strip
Produkt

Model(s) : 2835 CCT-05
Modell : RGB-05

Test Standard : EN IEC 55015:2019+A11:2020
Prüfnorm : EN IEC 61000-3-2:2019 + A1:2021 + A2:2024
EN 61000-3-3:2013 + A1:2019 + A2:2021
EN IEC 61547:2023

Test Report No. : ZHT-251124124E01
Bericht Nr

This Attestation of Compliance is issued on a voluntary basis for electrical equipment below the voltage limits of EMC Directive 2014/30/EU. The essential requirements are fulfilled accordingly based on the technical specifications applicable at the time of issuance. It is only valid in connection with the test report.

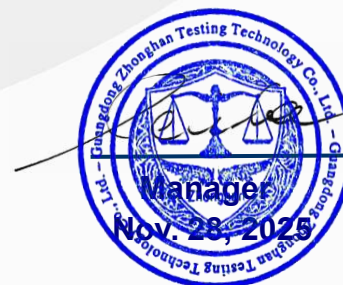

The information of the certificate can be checked through www.zht-lab.cn.
The CE mark which is shown on the certificate can only be used under the conditions that the products complete with all of the relevant Directives of EC Declaration of Conformity.
The Manufacturer should be responsible for the internal production control so that the products complied with the essential requirements of the above mentioned Directive(s). Certificate holder must notify all changes to the original certification laboratory of Guangdong Zhonghan Testing Technology Co., Ltd.



Guangdong Zhonghan Testing Technology Co., Ltd.

Address: Room 104/201, Building 1, Yibaolai Industrial Park, Qiaotou, Fuhai Subdistrict, Bao'an District, Shenzhen, Guangdong, China

Tel.: +86-755-27782934 **Http://**www.zht-lab.cn **E-mail:** admin@zht-lab.cn



Certificate of Compliance

Certificate Number: ZHT-251124124S01C

Certificate's Holder : Shenzhen Dengdai Yunlian Lighting Co., Ltd
Zertifikatsinhaber : 2nd Floor, Building A, No. 15 Jinkui East Road, Kuiyong Street,
DapengNew District, Shenzhen, Guangdong, China

Manufacturer : Shenzhen Dengdai Yunlian Lighting Co., Ltd
Hersteller : 2nd Floor, Building A, No. 15 Jinkui East Road, Kuiyong Street,
DapengNew District, Shenzhen, Guangdong, China

Trade Mark : VITO
Warenzeichen

Product : LED light strip
Produkt

Model(s) : 2835 CCT-05,
Bezeichnung : RGB-05

Test Standard : EN 60598-2-21:2015
Geprüft nach : EN IEC 60598-1:2024+A11:2024
EN IEC 62031:2020+A11:2021

Test Report No. : ZHT-251124124S01
Bericht Nr

This Certificate of Compliance is issued on a voluntary basis for General Product Safety Regulation of directive (EU)2023/988. The essential requirements are fulfilled accordingly based on the technical specifications applicable at the time of issuance. It is only valid in connection with the test report.



The information of the certificate can be checked through www.zht-lab.cn.
The CE mark which is shown on the certificate can only be used under the conditions that the products complete with all of the relevant Directives of EC Declaration of Conformity.
The Manufacturer should be responsible for the internal production control so that the products complied with the essential requirements of the above mentioned Directive(s). Certificate holder must notify all changes to the original certification laboratory of Guangdong Zhonghan Testing Technology Co., Ltd.



Guangdong Zhonghan Testing Technology Co., Ltd.

Address: Room 104/201, Building 1, Yibaolai Industrial Park, Qiaotou, Fuhai Subdistrict, Bao'an District, Shenzhen, Guangdong, China

Tel.: +86-755-27782934 [Http://www.zht-lab.cn](http://www.zht-lab.cn) **E-mail:admin@zht-lab.cn**



Certificate of Compliance

Certificate Number: ZHT-250114113R01C

Applicant Name / Zertifikatsinhaber : Shenzhen Dengdai Yunlian Lighting Co., Ltd
Address / Adresse : 2nd Floor, Building A, No. 15 Jinkui East Road, Kuiyong Street, Dapeng New District, Shenzhen, Guangdong, China
Manufacturer / Hersteller : Shenzhen Dengdai Yunlian Lighting Co., Ltd
Address / Adresse : 2nd Floor, Building A, No. 15 Jinkui East Road, Kuiyong Street, Dapeng New District, Shenzhen, Guangdong, China
Product / Produkt : CCT led strips
Main Model(s) / Hauptmodell(e) : 2835 CCT-05
Additional Model(s) / Zusätzliche(s) Modell(e) : 2835 CCT-03, 2835 CCT-12, 2835 CCT-24
Trade Mark / Warenzeichen : 
Test Standard / Geprüft nach : EN62479:2010, EN IEC 62368-1:2024+A11:2024
ETSI EN 301 489-1 V2.2.3, ETSI EN 300 328 V 2.2.2
ETSI EN 301 489-17 V3.2.4
Test Report No./Bericht Nr : ZHT-250114113R01

The certificate is issued in accordance with annex III of the RED Directive 2014/53/EU of 13th March 2014

This certificate of conformity is based on a single evaluation of the submitted sample(s) of the above mentioned product. It does not imply an assessment of the whole production and other relevant directives have to be observed.



The information of the certificate can be checked through www.zht-lab.cn.
The CE mark which is shown on the certificate can only be used under the conditions that the products complete with all of the relevant Directives of EC Declaration of Conformity.
The Manufacturer should be responsible for the internal production control so that the products complied with the essential requirements of the above mentioned Directive(s). Certificate holder must notify all changes to the original certification laboratory of Guangdong Zhonghan Testing Technology Co., Ltd.



Guangdong Zhonghan Testing Technology Co., Ltd.
Address: Room 104/201, Building 1, Yibaolai Industrial Park, Qiaotou, Fuhai Subdistrict, Bao'an District, Shenzhen, Guangdong, China
Tel.: +86-755-27782934 **Http://**www.zht-lab.cn **E-mail:** admin@zht-lab.cn