

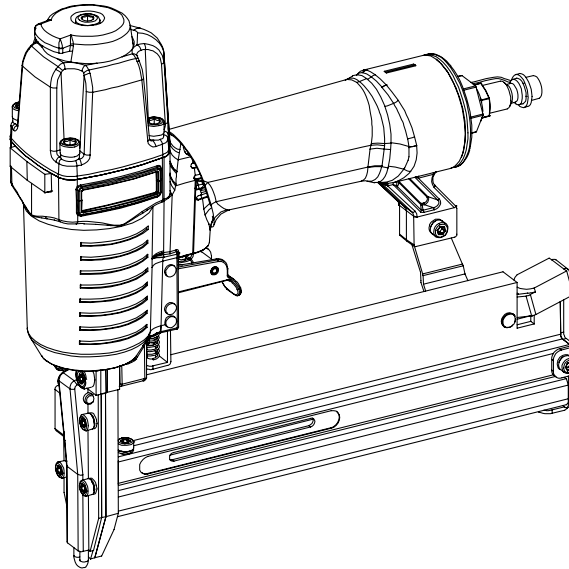

18-GAUGE 2-INCH 2-IN-1 NAILER



For replacement parts visit
WENPRODUCTS.COM

Model # 61718
bit.ly/wenvideo

IMPORTANT:

Your new tool has been engineered and manufactured to WEN's highest standards for dependability, ease of operation, and operator safety. When properly cared for, this product will supply you years of rugged, trouble-free performance. Pay close attention to the rules for safe operation, warnings, and cautions. If you use your tool properly and for intended purpose, you will enjoy years of safe, reliable service.



NEED HELP? CONTACT US!

Have product questions? Need technical support?
Please feel free to contact us at:

 **800-232-1195** (M-F 8AM-5PM CST)

 **techsupport@wenproducts.com**

 **WENPRODUCTS.COM**

NOTICE: Please refer to wenproducts.com for the most up-to-date instruction manual.

TABLE OF CONTENTS

Technical Data	2
Safety Introduction	3
Safety Rules	4
Know Your Nailer.....	7
Preparation and Adjustments.....	8
Operation.....	10
Maintenance	12
Troubleshooting	13
Exploded View and Parts List	14
Warranty Statement	16

TECHNICAL DATA

Model Number:	61718
Minimum Operating Pressure:	60 PSI
Maximum Operating Pressure:	100 PSI
Air Inlet:	1/4" - 18 NPT
Air Consumption per Nail:	0.5 CFM @ 90 PSI
Nail Type:	18 Gauge Brad
Nail Length:	5/8" to 2" (15 mm to 50 mm)
Staple Type:	18 Gauge 1/4" Narrow Crown
Staple Length:	5/8" to 1-5/8" (16 mm to 40 mm)
Magazine Capacity:	100 pcs
Weight:	3.4 lbs

SAFETY INTRODUCTION

Hello! Thank you for purchasing the WEN 2-in-1 Nailer & Stapler. Safe operation of this pneumatic tool requires that you read and understand this operator's manual and all labels affixed to the tool. Safety is a combination of common sense, staying alert, and knowing how your tool works.

The purpose of the following safety symbol is to attract your attention to possible dangers. We don't want any of our beloved WEN customers accidentally injuring themselves. The safety symbols and the explanations with them deserve your careful attention and understanding.



Safety Alert Symbol: Indicates danger, warning, or caution. This may be used in conjunction with other symbols. Always follow the safety precautions to reduce the risk of fire, electric shock and personal injury. However, please note that the safety warnings do not by themselves eliminate any danger. These instructions and warnings are not substitutes for proper accident prevention measures.

WARNING: Do not attempt to operate this tool until you have thoroughly read and understood all instructions, safety rules, etc., contained in this manual. Failure to comply can result in accidents involving fire, electric shock, or serious personal injury. Save this operator's manual and review frequently for continuing safe operation and instructing others who may use this tool.

SAFETY RULES

Safety is a combination of common sense, staying alert and knowing how your item works.

SAVE THESE SAFETY INSTRUCTIONS.



WARNING: To avoid mistakes and serious injury, do not use your tool until the following steps have been read and understood

1. **READ** and become familiar with this entire instruction manual, no matter how boring it may be. **LEARN** the tool's applications, limitations, and possible hazards.
2. **ALWAYS** keep your work area clean, uncluttered, and well lit. **DO NOT** work on floor surfaces that are slippery with sawdust or wax.
3. **DO NOT USE THE TOOL** in the presence of flammable dust, gases or fumes. The tool may produce a spark that could ignite gases causing a fire. Driving a nail into another nail may also cause a spark.
4. **KEEP BYSTANDERS AT A SAFE DISTANCE** from the work area, especially when the tool is operating. **NEVER** allow children or pets near the tool.
5. **MAKE THE WORKSHOP CHILDPROOF.** Use padlocks and master switches and **ALWAYS** remove starter keys. Keep bystanders, children and visitors away while operating the power tool. Distractions can cause you to lose control. When tool is not in use, it should be locked away in a safe place.
6. **DRESS FOR SAFETY.** Do not wear loose clothing, gloves, neckties, or jewelry (rings, watches, etc.) when operating the tool. Inappropriate clothing and items can get caught in moving parts and draw you in. **ALWAYS** wear non-slip footwear and tie back long hair.
7. **USE PERSONAL PROTECTIVE EQUIPMENT.**
 - Everyone in the work area **MUST** wear safety glasses with side shields that conform to ANSI Z87.1 requirements (approved glasses have "Z87" printed or stamped on them). It is the employer's responsibility to enforce the use of eye protection equipment by both the tool operator and others in the work area.
 - Wear a face mask or dust mask to fight the debris produced by operation.
 - Wear ear protection such as plugs or muffs to fight hearing loss.
 - Wear work gloves to protect your hands.
8. **KEEP ALERT.** Watch what you are doing. Use common sense. Do not operate any tool when you are tired or under the influence of drugs, alcohol or medication that may affect your ability to properly use the tool.
9. **DO NOT OVERREACH.** Keep proper footing and balance at all times. Wear oil-resistant rubber-soled footwear. Keep the floor clear of oil, scrap, and other debris.
10. **DO NOT FORCE THE TOOL** to do a job for which it was not designed.
11. **INSPECT TOOL BEFORE USE.** Do not operate if any portion of the tool, trigger, or safety bracket is damaged, inoperable, disconnected, or altered. Leaking air, damaged parts, or missing parts should be repaired or replaced before use
12. **WHEN CONNECTING TO THE AIR SUPPLY,** the tool is at risk of possibly firing fasteners. Be aware of this and do not aim the gun at anything you do not want to shoot a nail into.

SAFETY RULES

13. **USE ONLY** clean dry and regulated air. Condensation from an air compressor can rust and damage the internal workings of the tool.
14. **DO NOT USE BOTTLED GASES** to power this tool. Bottled compressed gases including but not limited to oxygen, carbon dioxide, nitrogen, hydrogen, propane, acetylene or air are not for use with pneumatic tools. Never use combustible gases or any other reactive gas as a power source for this tool. **DANGER OF EXPLOSION AND/OR SERIOUS PERSONAL INJURY MAY RESULT.**
15. **REGULATE AIR PRESSURE.** Use air pressure that is compatible with the ratings on the nameplate of the tool (60 to 100 PSI). **DANGER** - Never let the air pressure go above 120 PSI.
16. **USE PROPER EXTENSION CORDS.** When using an air compressor outdoors, use only rounded jackets extensions cords. These are intended for outside use. See manufacturer's manual for the AWG required for the compressor's amperage draw.
17. **ALWAYS USE** an air hose that is rated at a maximum working pressure of at least 150 PSI (10.3 bar) or 150% of the maximum system pressure (whichever is higher).
18. **PAY ATTENTION TO AIR HOSE AND THEIR CONNECTIONS.** Don't trip over the hoses. Also, make sure the connections are nice and tight. Use appropriate hose tape to prevent leaking.
19. **MAKE SURE HOSE** is free of obstructions or snags. Entangled or snarled hoses can cause a loss of balance.
20. **USE COUPLINGS** that relieve all pressure from the tool when it is disconnected from the power supply. Use hose connectors that shut off the air supply from the compressor when the tool is disconnected.
21. **LOAD FASTENERS AFTER** connecting the tool to the air supply. Otherwise, fasteners are at risk of being fired during connection. The tool's driving mechanism may cycle when it is connected to the air supply.
22. **DO NOT DEPRESS THE SAFETY BRACKET OR THE TRIGGER WHEN LOADING.**
23. **ALWAYS ASSUME** that the tool contains fasteners. Do not point the tool at coworkers or yourself at any time, nails may be fired unintentionally and cause serious injury.
24. **DO NOT DISCHARGE** fasteners into open air, concrete, stone, extremely hard woods, knots or any material too hard for the fastener to penetrate.
25. Do not use the body of the tool or top cap as a hammer. Discharged fasteners may follow unexpected paths and cause bodily injury.
26. **KEEP HANDS AND BODY PARTS CLEAR** of immediate work area. Hold workpiece with clamps when necessary to keep body parts out of potential harm. Be sure the workpiece is properly secured before pressing the nailer against the material. The safety bracket may cause the work material to shift unexpectedly.
27. **GRIP THE TOOL FIRMLY** with both hands to maintain control while still allowing it to recoil away from the work surface as the fastener is driven.

SAFETY RULES

28. **KEEP FACE AND BODY PARTS** away from the back of the tool cap when working in restricted areas. Sudden recoil can result in impact to the body, especially when nailing into hard or dense material.
29. **DO NOT DRIVE FASTENERS** near the edge of your work material. The workpiece may split, causing the fastener to ricochet, injuring you or a bystander. Be aware that the nail may follow the grain of the wood, causing it to protrude unexpectedly from the side of the work material. Drive the nail perpendicular to the grain to reduce risk of injury.
30. **DO NOT DRIVE NAILS** onto the heads of other fasteners. Do not use the tool at too steep of an angle. Personal injury from strong recoil, jammed fasteners, or ricocheted nails may result.
31. **BE AWARE OF MATERIAL THICKNESS** when using the nailer. A protruding nail may cause injury.
32. **KNOW** that when the tool is being utilized at pressures on the high end of its operating range, nails can be driven completely through thin or very soft work material. Make sure the pressure in the compressor is set so that nails are set into the material and not pushed completely through.
33. **REMOVE FINGER FROM TRIGGER** when not driving fasteners. Never carry the tool with your finger on the trigger.
34. **IF THE FASTENERS ARE JAMMED**, disconnect the tool from the air supply first before removing the jammed fasteners.
35. **DISCONNECT** tool from air supply when not in use. Remove fasteners from magazine before leaving the area or passing the tool to another operator. Do not climb ladders, stairs, scaffoldings, etc. without disconnecting the tool. Do not carry a connected tool to another work area. Do not make adjustments, remove magazine, perform maintenance or clear jammed fasteners while connected to the air supply. If the safety bracket is adjusted when the tool is connected to the air supply with loaded nails, accidental discharge may occur.
36. **DO NOT REMOVE**, tamper with, or otherwise cause the tool, trigger or safety bracket to become inoperable. Do not tape or tie the trigger or safety bracket in the ON position. Do not remove springs from the safety bracket. Make daily inspections for free movement of the trigger and safety bracket. Uncontrolled discharge may result. Do not alter or modify the tool in any way.
37. **MAINTAIN TOOLS PROPERLY. ALWAYS** keep tools clean and in good working order. Follow instructions for lubricating , changing accessories and storage.



WARNING: The warnings, cautions, and instructions explained in this manual cannot cover all possible conditions and situations that may occur. It must be understood by the operator that **COMMON SENSE AND CAUTION ARE FACTORS WHICH CANNOT BE BUILT INTO THIS PRODUCT, BUT MUST BE SUPPLIED BY THE OPERATOR.**

KNOW YOUR NAILER

Carefully unpack the tool from the packaging. Check all components and compare against the graph below. If any part is damaged or missing, please contact our customer service at (800) 232-1195, M-F 8-5 CST or email us at techsupport@wenproducts.com.

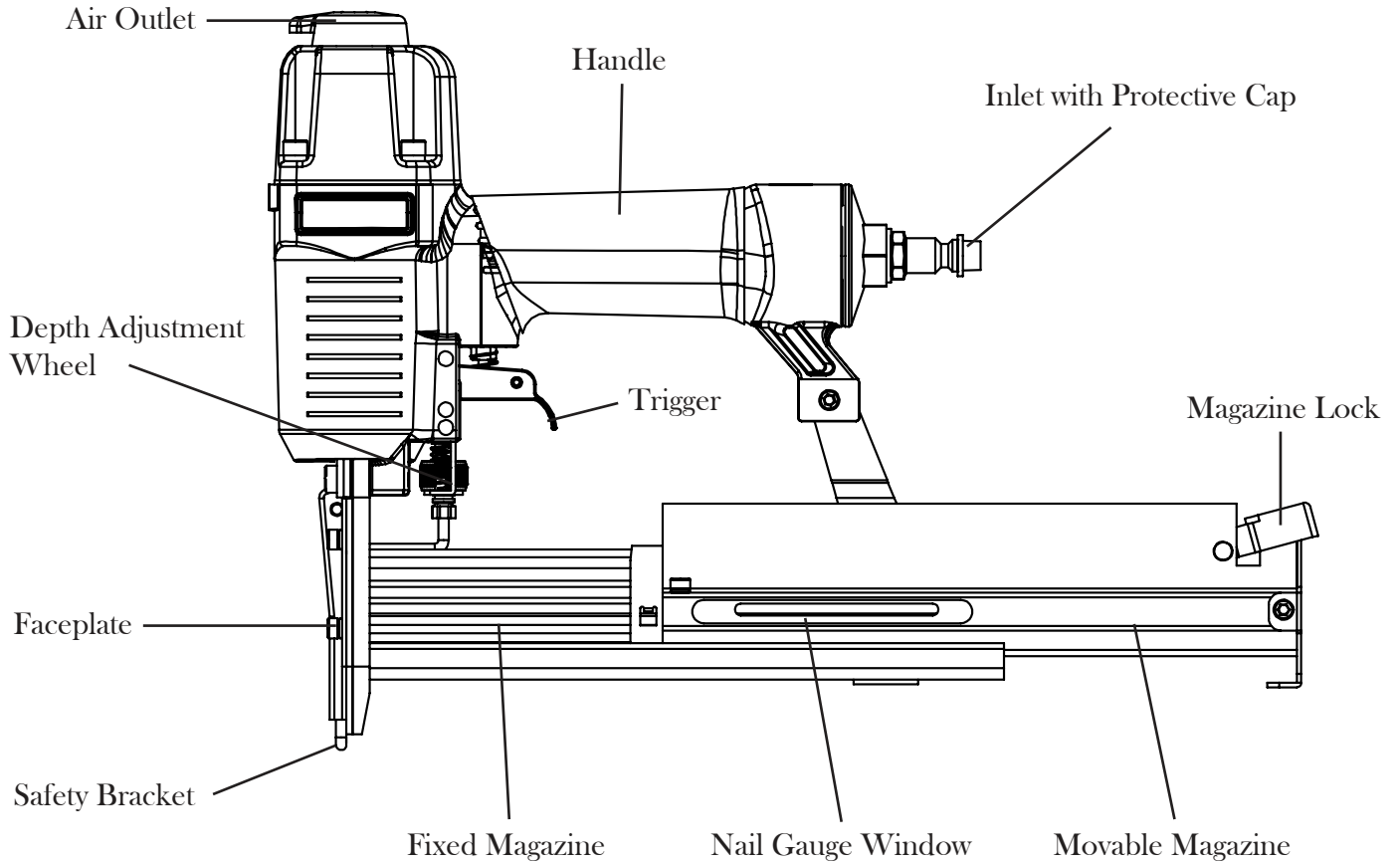

PACKAGE CONTENT	QTY
2-in-1 Nailer	1
3mm Hex Key	1
4mm Hex Key	1
Air Tool Lubricating Oil	1
Safety Glasses	1
Blow Mold Case	1

PREPARATION AND ADJUSTMENTS

LUBRICATING THE TOOL (Fig. 1)

This tool requires lubrication before each use (especially the first use). Proper lubrication is the owner's responsibility. Failure to lubricate the tool properly will dramatically shorten the life of the tool and void the warranty.

NOTE: The in-line oiler is a convenient way to provide oil to the tool. If an in-line oiler is installed, manual lubrication through the air inlet is not required.

1. Always make sure the tool is disconnected from the air supply before adding lubricant.

2. Turn the tool so the air inlet is facing up. Open the protective cap. Place 3 to 4 drops of air tool lubrication oil into the air inlet (Fig. 1).

NOTE: Excessive lubrication may damage the work surface.

3. Close the protective cap. Wipe off any excess oil from the inlet.

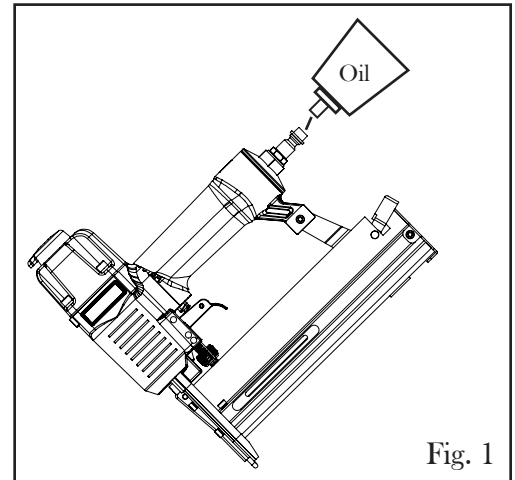

Fig. 1

CONNECTING THE TOOL TO AN AIR SUPPLY (Fig. 2)

Your tool should be connected to a properly installed compressed air supply. The working pressure of the air compressor must be regulated by a regulator to fit the operating pressure of your nailer (60-100 PSI). Refer to the diagram on the bottom (Fig. 2) for the recommended accessories and connection order.



WARNING: Make sure the nailer magazine is empty and the tip of the nailer is pointed away from you when connecting to air supply.



WARNING: Use only clean dry and regulated air. Do not use bottled gases to power this tool. Danger of explosion and/or serious personal injury may result. Do not operate when the air pressure is outside of the recommended range (60 to 100 PSI).

1. Turn on the compressor on and set the regulator (Fig. 2 - Regulator) to the proper pressure within 60 to 100 PSI. The pressure can be adjusted later depending on firing depth, the length of nails and the hardness of the workpiece.

2. Connect the compressed air hose to the inlet of your air compressor. Connect the other end of the air hose to the air inlet of the nailer. The connections must click into place audibly. Use appropriate hose tape to prevent leaking.

3. To disconnect the tool from the air hose, pull back the ring on the quick connector to release the connection. Repeat for disconnecting the air compressor from the air hose.

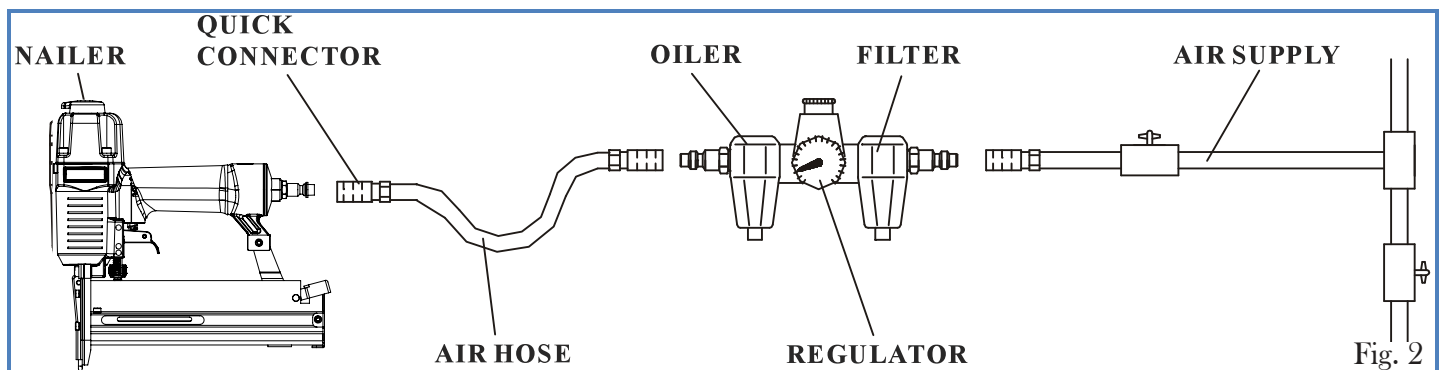

Fig. 2

PREPARATION AND ADJUSTMENTS

LOADING THE FASTENERS



WARNING: Always load the fasteners after connecting the tool to its air supply. Otherwise, unwanted misfires may occur during connection. Never aim the tip towards yourself or others.

1. Depress the magazine lock and pull out the movable magazine fully (Fig 3).

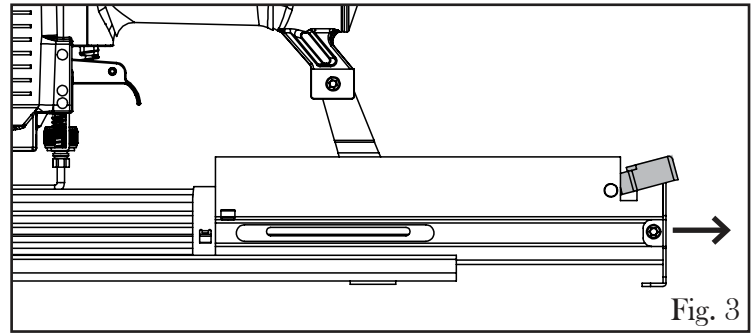

2. Hold the nailer with the magazine to your side. Make sure the firing tip is directed away from yourself or others.

3. Your nailer accepts either 18 gauge brad nails 5/8" - 2" in length or 18 gauge 1/4" narrow crown staples 5/8" - 1-5/8" in length (Fig. 4). A maximum of 100 fasteners may be loaded in the magazine.

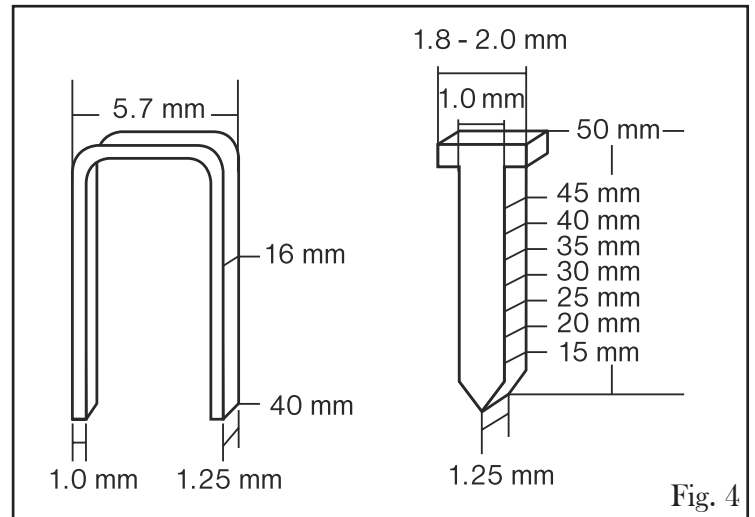

A. Loading Staples: Place a clip of staples over the fixed magazine track as shown (Fig. 5).

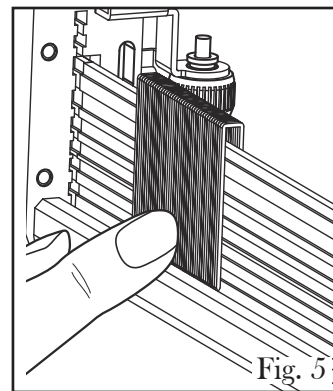

B. Loading Nails: Place a clip of nails into the grooves of the fixed magazine with the nail tips pointing downwards (Fig. 6). Make sure the heads of the nails rest on the appropriate groove and that the base of the nails are against the bottom of the magazine.

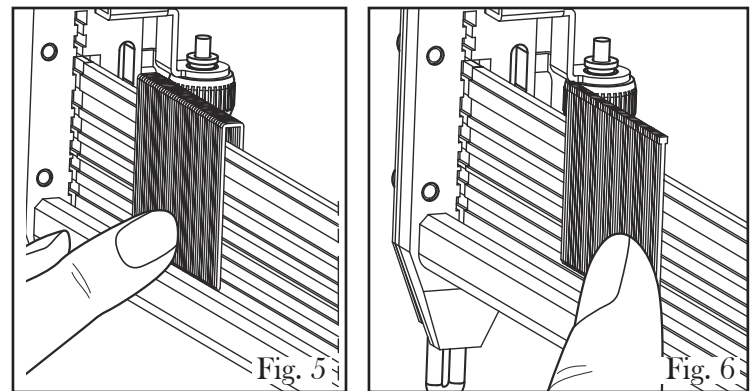

4. Push the movable magazine forward until it is locked. **NOTE:** Some force may be required to fully close the magazine when nails are loaded.

ADJUSTING THE AIR OUTLET (Fig. 7)

Air will be released from the air outlet during operation. Rotate the adjustable air outlet cap (Fig. 7) on the top of the nailer to direct the released air at your preferred direction, away from you and the workpiece.

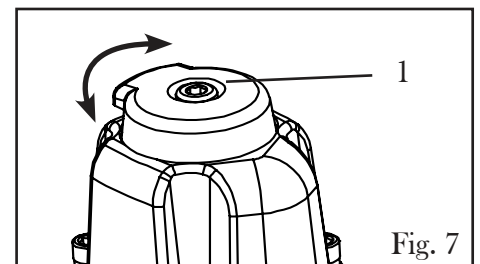

OPERATION



WARNING: Before each use, check the nail, compressed air connections and air lines. If any parts are missing or damaged, do not operate this tool until the parts are repaired and replaced. Failure to do so could possibly result in a serious personal injury.

ADJUSTING THE DEPTH ADJUSTMENT WHEEL

The nailer is equipped with a depth adjustment wheel (Fig. 8) for setting the penetration depth of the fasteners.

1. Turn the wheel clockwise to increase the firing depth (wheel moves downwards).
2. Turn the wheel counterclockwise to decrease the firing depth (wheel moves upwards).

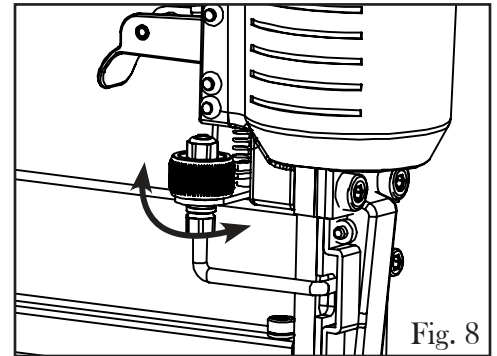

Fig. 8

SHOOTING NAILS



WARNING: Using a nail gun can be dangerous. To reduce the risk of injury, always wear proper eye and hearing protection when operating this tool. Stay alert and keep proper balance at all times. Always release the trigger when not operating the nail gun to reduce the risk of unintended nail discharge.

1. Check that the air supply is correctly connected to the tool at the correct pressure and the fasteners have been loaded into the magazine.
2. Test the driving depth on a sample piece of wood. If the fasteners penetrate too far, decrease the firing depth or adjust the regulator to provide less air pressure. If the fasteners penetrate too shallow, increase the firing depth or adjust the regulator to provide more air pressure. Try to adjust both the air pressure regulator and the depth wheel so that you can achieve your desired firing depth with the lowest possible air pressure. This will save energy, reduce noise level and reduce the wear on the tool.
3. Hold the nailer upright on the workpiece and position the safety bracket where the fastener will be driven (Fig. 9).
4. Carefully press down on the safety bracket (Fig. 9 - 1) and pull the trigger (Fig. 9 - 2) to drive a fastener.
4. Release the trigger, lift the tool off the workpiece and reposition it where the next fastener will be driven. Repeat step 4 to drive another fastener.
5. Regularly check the nail gauge window to see the load of fasteners in the magazine. Make sure to refill the magazine before the fasteners run out. As blank shots can damage the tool and leave unwanted marks on the workpiece.

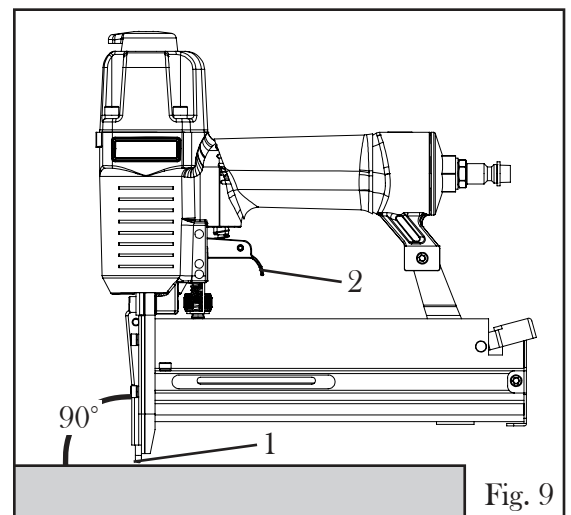

Fig. 9



WARNING: If the safety bracket is not functioning as described above, you should stop using the tool immediately and disconnect it from the air supply.

6. After operation, turn off the air compressor and depressurize the compressor according to the instructions stated with your compressor. Disconnect the air hose from the nailer and attach the protective cap to the nailer inlet.

OPERATION

DRIVING MODE

This nailer follows a single driving mode, which means only one nail will be driven at a time. There is no bump-fire mode for this nailer. This type of driving mode minimizes the chances of accidental firing and maximizes safety.

The nailer is equipped with a safety bracket that needs to be activated before pulling the trigger in order to drive a fastener. The driving process can only be triggered in the following sequence of activation:

1. The safety bracket is pressed down by contacting the workpiece.
2. The operator pulls the trigger. A nail will be driven every time the trigger is pulled, as long as the safety bracket stays depressed.

CLEARING JAMMED FASTENERS



WARNING: Disconnect air line from the tool and remove all fasteners before removing jammed nails to avoid personal injury. Keep the tool pointed away from yourself and others.

1. Disconnect the nailer from the air supply and remove all fasteners from the magazine.

2. The fastener could be jammed in the magazine or in the nosepiece. Make sure to keep the nailer pointed away from yourself or others when removing jammed nails.

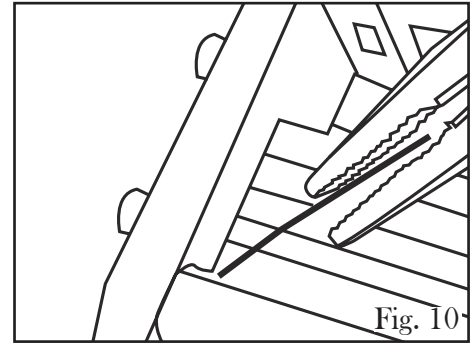

A. To Clear Fasteners From the Magazine:

Press the magazine lock to pull out the movable magazine. Carefully remove the jammed nail or staple with a pair of pliers or other tools if necessary (Fig. 10). Firmly close the magazine.

B. To Clear Fasteners From the Nosepiece:

Loosen the three screws on the faceplate (Fig. 11 - 1) with the included hex key. Carefully remove the jammed nail or staple with a pair of pliers or other tools if necessary. Reattach the front plate and secure the three screws.

3. Reattach the nailer to the air supply. Load the magazine and test fire a nail into a scrap wood to confirm the nailer is working properly again.

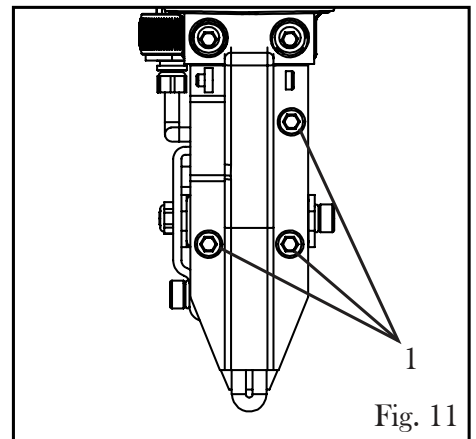

WARNING: If nails continue to jam, stop using the nailer contact our customer service at 800-232-1195 (M-F 8-5 CST).

MAINTENANCE



WARNING: Disconnect tool from air supply and empty fasteners from the magazine before performing any cleaning or maintenance.

LUBRICATION

Routine lubrication of the tool is required for best performance. If tool is used without an in-line oiler, place 3 to 4 drops of pneumatic tool oil into the air inlet of the tool at the beginning of each workday. This will ensure the moving components are finely lubricated.

CLEANING

Keep tools clean for better and safer performance. Wipe the tool clean with a damp towel and some soft soap. Blow the tool clean using compressed air, then use non-flammable cleaning solutions to wipe exterior of the tool as necessary. Do not soak tool with cleaning solutions. Such solutions can damage internal parts.

INSPECTION

1. Inspect trigger and safety mechanism to assure system is complete and functional (no loose or missing parts, no binding or sticking parts). Do not operate if any portion of the tool, trigger, or safety bracket is damaged, inoperable, disconnected, or altered. Leaking air, damaged parts, or missing parts should be repaired or replaced before use.
2. Keep all screws tight. Loose screws can cause personal injury or damage the tool.
3. Dirt and water in the air supply are major causes of pneumatic tool wear. Follow the compressor instructions to check the filter of the compressor and drain water and contaminations out from the compressor.

STORAGE

Place the tool and accessories inside the blow mold case to protect it from dust and moisture. Store the unit and accessories in a dark, dry, frost-free and well ventilated place, out of the reach of children. The ideal storage temperature is between 50 to 86 °F (10 and 30 °C).

PRODUCT DISPOSAL

Used pneumatic tools contain recyclable materials and should not be disposed with household waste. Please take this product to your local recycling facility for responsible disposal and to minimize its environmental impact.

TROUBLE SHOOTING



WARNING: Stop using the tool immediately if any of the following problems occur or risk serious personal injury. Repairs and replacements should only be performed by authorized personnel at a certified WEN service center.

Problem	Common Causes	Solution
Air leaking at trigger area	<ol style="list-style-type: none"> 1. O-ring in trigger valve is damaged. 2. Trigger valve head is damaged. 3. Trigger valve stem, seal or O-ring is damaged. 	<ol style="list-style-type: none"> 1. Check and replace O-ring. 2. Check and replace trigger valve head. 3. Check and replace trigger valve stem, seal or O-ring.
Air leaking between body and drive guide	Damaged piston O-ring or bumper.	Check and replace O-ring or bumper.
Air leaking between body and cylinder cap	<ol style="list-style-type: none"> 1. Loose screw. 2. Damaged seal. 	<ol style="list-style-type: none"> 1. Tighten screws. 2. Check and replace seal.
Trigger is pressed but no fastener is driven.	<ol style="list-style-type: none"> 1. Not properly connected to air supply. 2. Air hose is leaking. 3. Fasteners not installed correctly 4. Operating pressure too low. 	<ol style="list-style-type: none"> 1. Check air supply connections. 2. Check air hose for leaks. 3. Load fasteners into the magazine correctly. 4. Increase operating pressure.
Fasteners are driven too deep	<ol style="list-style-type: none"> 1. Worn bumper. 2. Air pressure is too high. 3. The depth setting is too shallow. 	<ol style="list-style-type: none"> 1. Replace bumper. 2. Adjust the air pressure. 3. Adjust the depth wheel.
Runs slowly or has power loss	<ol style="list-style-type: none"> 1. Insufficient oil. 2. Insufficient air supply. 3. Broken spring in cylinder cap. 4. Exhaust port in cylinder cap is blocked. 	<ol style="list-style-type: none"> 1. Lubricate as instructed. 2. Check air supply. 3. Replace spring. 4. Replace damaged internal parts.
Tool skips a fastener	<ol style="list-style-type: none"> 1. Worn bumper or damaged spring. 2. Dirt in drive guide. 3. Inadequate airflow to tool. 4. Worn or dry O-ring on piston. 5. Damaged O-ring on trigger valve. 6. Cylinder cap seal leaking. 	<ol style="list-style-type: none"> 1. Replace bumper or pusher spring. 2. Clean drive channel of front plate. 3. Check hose and compressor fittings. 4. Replace O-ring or lubricate. 5. Replace O-ring. 6. Replace seal.
Fasteners repeatedly jam	<ol style="list-style-type: none"> 1. Joint guide is worn. 2. Fasteners are wrong size or damaged. 3. Magazine or front plate screws are loose. 4. Blade in piston assembly is damaged. 	<ol style="list-style-type: none"> 1. Replace joint guide. 2. Use the recommended and undamaged fasteners. 3. Tighten screws. 4. Replace piston assembly.
Tool will not drive down tight	<ol style="list-style-type: none"> 1. Worn blade in piston assembly. 2. Insufficient air pressure. 3. Slow cycling and loss of power. 	<ol style="list-style-type: none"> 1. Replace piston assembly. 2. Adjust to adequate air pressure. 3. Check cylinder cap spring for broken coils or reduced length. Check if exhaust port of cylinder cap is restricted.

EXPLODED VIEW AND PARTS LIST

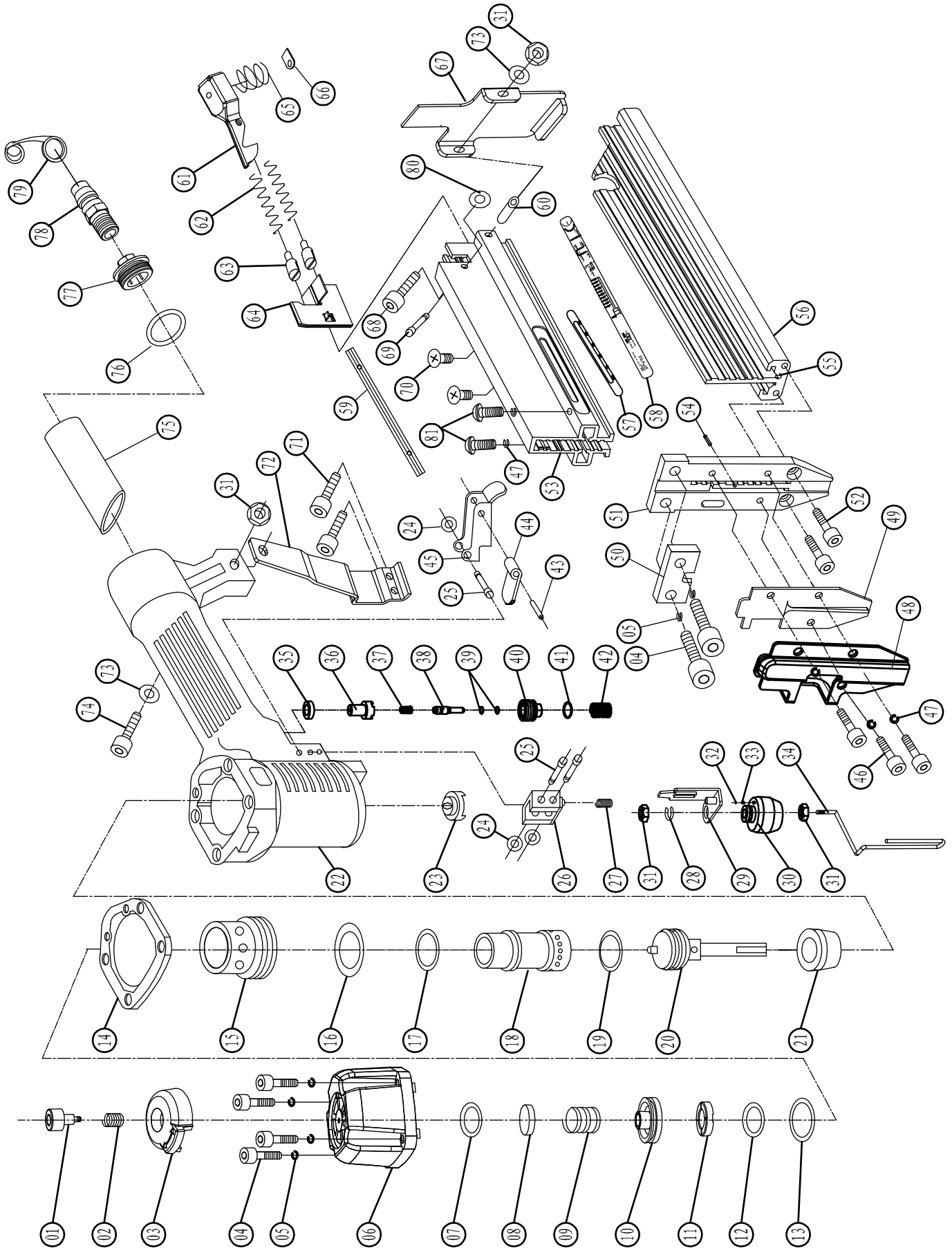

EXPLODED VIEW AND PARTS LIST

No.	Parts No.	Description	Qty
1	61718-001	Bolt	1
2	61718-002	Deflector Spring	1
3	61718-003	Air Outlet Cap	1
4	61718-004	Bolt M5×20	6
5	61718-005	Spring Washer	6
6	61718-006	Cylinder Cover	1
7	61718-007	O-Ring 13.7×2.4	1
8	61718-008	Flat Washer	1
9	61718-009	Compressed Spring	1
10	61718-010	Switch Valve	1
11	61718-011	Sealing Washer	1
12	61718-012	O-Ring 24.8×3.5	1
13	61718-013	O-Ring 31.2×2.5	1
14	61718-014	Collar	1
15	61718-015	O-Ring 42.6×2.35	1
16	61718-016	O-Ring 30×1.8	1
17	61718-017	Sealing Washer	1
18	61718-018	Cylinder	1
19	61718-019	O-Ring 29.7×3.55	1
20	61718-020	Main Piston	1
21	61718-021	Bumper	1
22	61718-022	Gun Body	1
23	61718-023	Rubber Washer	3
24	61718-024	O-Ring 1.7x2	3
25	61718-025	Pin	1
26	61718-026	Safety Stand	1
27	61718-027	Spring	1
28	61718-028	Snap Retainer	1
29	61718-029	Tip stand	1
30	61718-030	Adjustment Nut	1
31	61718-031	Nut M4	4
32	61718-032	Pusher Spring	1
33	61718-033	Steel Ball	1
34	61718-034	Safety Stand	1
35	61718-035	Rectangle Seal	1
36	61718-036	Trigger Valve Guide	1
37	61718-037	Compressed Spring	1
38	61718-038	Trigger Valve Stem	1
39	61718-039	Pin 2.5×1.5	2
40	61718-040	Trigger Valve Seat	1
41	61718-041	O-Ring 11.2×2	1

No.	Parts No.	Description	Qty
42	61718-042	Compressed Spring	1
43	61718-043	Pin 2.5×16	1
44	61718-044	Safety Space	1
45	61718-045	Trigger	1
46	61718-046	Bolt M4×10	3
47	61718-047	Spring Washer 4	5
48	61718-048	Face Plate	1
49	61718-049	Driver Guide Cover	1
50	61718-050	Spacer	1
51	61718-051	Driver Guide	1
52	61718-052	Bolt M4×14	2
53	61718-053	Movable Magazine	1
54	61718-054	Pin 1.5×10	1
55	61718-055	Inlay Slice	1
56	61718-056	Fixed Magazine	1
57	61718-057	Indicate Label	1
58	61718-058	Sticker Plate	1
59	61718-059	Slice	1
60	61718-060	Core Pin	1
61	61718-061	Fixed Lever	1
62	61718-062	Compressed Spring	2
63	61718-063	Pusher Pipe	2
64	61718-064	Pusher	1
65	61718-065	Compressed Spring	1
66	61718-066	Washer	1
67	61718-067	Fixed Seat	1
68	61718-068	Bolt M4×38	1
69	61718-069	Pin	1
70	61718-070	Bolt M4×6	2
71	61718-071	Bolt M4×6	2
72	61718-072	Support Seat	1
73	61718-073	Washer 4	2
74	61718-074	Bolt M4×20	1
75	61718-075	Rubber Handle Case	1
76	61718-076	O-Ring 36.3×3.55	1
77	61718-077	End Cap	1
78	61718-078	Air Inlet Plug	1
79	61718-079	Air Plug Cap	1
80	61718-080	O-Ring 2.4x1.6	1
81	61718-081	Hexagon Socket Button Head Screws M4x14	2

LIMITED TWO YEAR WARRANTY

WEN Products is committed to build tools that are dependable for years. Our warranties are consistent with this commitment and our dedication to quality.

LIMITED WARRANTY OF WEN CONSUMER POWER TOOLS PRODUCTS FOR HOME USE

GREAT LAKES TECHNOLOGIES, LLC (“Seller”) warrants to the original purchaser only, that all WEN consumer power tools will be free from defects in material or workmanship for a period of two (2) years from date of purchase. Ninety days for all WEN products, if the tool is used for professional use.

SELLER’S SOLE OBLIGATION AND YOUR EXCLUSIVE REMEDY under this Limited Warranty and, to the extent permitted by law, any warranty or condition implied by law, shall be the repair or replacement of parts, without charge, which are defective in material or workmanship and which have not been misused, carelessly handled, or misrepaired by persons other than Seller or Authorized Service Center. To make a claim under this Limited Warranty, you must make sure to keep a copy of your proof of purchase that clearly defines the Date of Purchase (month and year) and the Place of Purchase. Place of purchase must be a direct vendor of Great Lakes Technologies, LLC. Third party vendors such as garage sales, pawn shops, resale shops, or any other secondhand merchant void the warranty included with this product. Contact techsupport@wenproducts.com or 1-800-232-1195 to make arrangements for repairs and transportation.

When returning a product for warranty service, the shipping charges must be prepaid by the purchaser. The product must be shipped in its original container (or an equivalent), properly packed to withstand the hazards of shipment. The product must be fully insured with a copy of the warranty card and/or the proof of purchase enclosed. There must also be a description of the problem in order to help our repairs department diagnose and fix the issue. Repairs will be made and the product will be returned and shipped back to the purchaser at no charge.

THIS LIMITED WARRANTY DOES NOT APPLY TO ACCESSORY ITEMS THAT WEAR OUT FROM REGULAR USAGE OVER TIME INCLUDING BELTS, BRUSHES, BLADES, ETC.

ANY IMPLIED WARRANTIES SHALL BE LIMITED IN DURATION TO ONE (1) YEAR FROM DATE OF PURCHASE. SOME STATES IN THE U.S., SOME CANADIAN PROVINCES DO NOT ALLOW LIMITATIONS ON HOW LONG AN IMPLIED WARRANTY LASTS, SO THE ABOVE LIMITATION MAY NOT APPLY TO YOU.

IN NO EVENT SHALL SELLER BE LIABLE FOR ANY INCIDENTAL OR CONSEQUENTIAL DAMAGES (INCLUDING BUT NOT LIMITED TO LIABILITY FOR LOSS OF PROFITS) ARISING FROM THE SALE OR USE OF THIS PRODUCT. SOME STATES IN THE U.S. AND SOME CANADIAN PROVINCES DO NOT ALLOW THE EXCLUSION OR LIMITATION OF INCIDENTAL OR CONSEQUENTIAL DAMAGES, SO THE ABOVE LIMITATION OR EXCLUSION MAY NOT APPLY TO YOU.

THIS LIMITED WARRANTY GIVES YOU SPECIFIC LEGAL RIGHTS, AND YOU MAY ALSO HAVE OTHER RIGHTS WHICH VARY FROM STATE TO STATE IN THE U.S., PROVINCE TO PROVINCE IN CANADA AND FROM COUNTRY TO COUNTRY.

THIS LIMITED WARRANTY APPLIES ONLY TO PORTABLE ELECTRIC TOOLS, BENCH POWER TOOLS, OUTDOOR POWER EQUIPMENT AND PNEUMATIC TOOLS SOLD WITHIN THE UNITED STATES OF AMERICA, CANADA AND THE COMMONWEALTH OF PUERTO RICO. FOR WARRANTY COVERAGE WITHIN OTHER COUNTRIES, CONTACT THE WEN CUSTOMER SUPPORT LINE.