

INSTALLATION INSTRUCTIONS

Operator: Save these instructions for future use!

FAILURE TO READ AND FOLLOW ALL INSTRUCTIONS CAREFULLY BEFORE INSTALLING OR OPERATING THIS CONTROL COULD CAUSE PERSONAL INJURY AND/OR PROPERTY DAMAGE.

DESCRIPTION

This low voltage thermostat is designed to operate with the White-Rodgers 8A18Z-2 Evaporative Cooler Control. For versatility, the thermostat subbase has a System Switch that lets you select VENT, COOL or OFF positions. The Fan Switch offers the selection of LOW or HIGH fan speed.

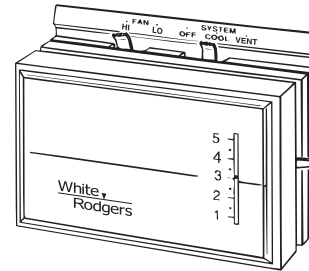

PRECAUTIONS

If in doubt about whether your wiring is millivolt, line, or low voltage, have it inspected by a qualified heating and air conditioning contractor, electrician, or someone familiar with basic electricity and wiring.

Do not exceed the specification ratings.

All wiring must conform to local and national electrical codes and ordinances.

This control is a precision instrument, and should be handled carefully. Rough handling or distorting components could cause the control to malfunction.

⚠ CAUTION

To prevent electrical shock and/or equipment damage, disconnect electric power to system, at main fuse or circuit breaker box, until installation is complete.

Do not short out terminals on gas valve or primary control to test. Short or incorrect wiring will burn out heat anticipator and could cause personal injury and/or property damage.

⚠ WARNING

Do not use on circuits exceeding 30 volts. Higher voltage will damage control and could cause shock or fire hazard.

SPECIFICATIONS

ELECTRICAL DATA

Switch Rating: 24VAC (30VAC max.)
Cooling - 0 to 1.5 Amps

Switch Action: SPST - Snap Action switch

THERMAL DATA

Temperature Scale Range: 1 to 5 (Cooler to Warmer)
Differential: 1°F

ATTENTION!

This product does not contain mercury. However, this product may replace a unit which contains mercury. Do not open mercury cells. If a cell becomes damaged, do not touch any spilled mercury. Wearing non-absorbent gloves, take up the spilled mercury with sand or other absorbent material and place into a container which can be sealed. If a cell becomes damaged, the unit should be discarded. Mercury must not be discarded in household trash. When the unit this product is replacing is to be discarded, place in a suitable container and refer to www.white-roddgers.com for location to send the product containing mercury.

INSTALLATION

ATTACH SUBBASE TO WALL

1. Route wires from the cooling equipment to the thermostat location and pull wires through hole in wall so that 6 inches of cable protrudes.
2. Pull wires through opening near center of subbase and connect wires beneath terminal screws as shown under wiring.
3. Push excess wiring into wall and plug hole with fire-resistant material (such as fiberglass insulation) to prevent drafts from affecting thermostat operation.
4. Fasten subbase loosely to wall, as shown, using two mounting screws. Place a level against bottom of subbase, adjust until level, and then tighten mounting screws to secure subbase.

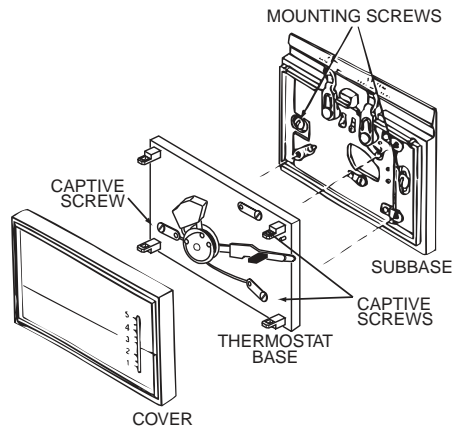

ATTACH THERMOSTAT TO SUBBASE

1. Remove cover from thermostat base by gripping the base in one hand. Use the other hand to pull gently at the top or bottom of the cover.
2. Carefully remove the shipping protective packing from the switch.

3. Attach thermostat base to subbase, being sure that all captive screws are tightened snugly, since they serve as electrical connections between thermostat and subbase.
4. Snap cover on thermostat base and set temperature lever to desired setting. The thermostat scale has numbers from 1 to 5. The lower numbers represent cooler temperature and the higher numbers represent warmer temperature.

WIRING

Take care when securing and routing wires so they do not short to adjacent terminals or rear of thermostat. Personal injury and/or property damage may occur.

All wiring should be installed according to local and national electrical codes and ordinances.

Refer to instruction sheet for 8A18Z-2, Evaporative Cooler Control for typical system hookup.

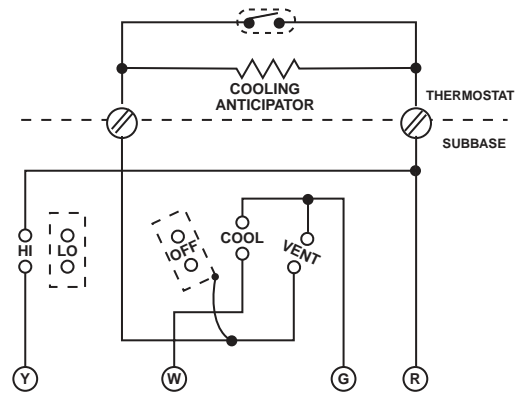

OPERATION

The chart below illustrates system and thermostat function during various modes of operation.

SUBBASE SWITCH POSITIONS					SYSTEM FUNCTION			COMPONENT OPERATION
FAN		SYSTEM			FAN TIMER RELAY	FAN SPEED RELAY	PUMP RELAY	
HI	LO	OFF	COOL	VENT				
	●	●						NO FAN - NO PUMP - NO COOL
	●		●		●		●	COOLING MODE - Pump relay and Fan timer relay energized by thermostat. Water begins circulating on cooler pads, fan will start on low speed after short time delay.*
●			●		●	●	●	COOLING MODE - Pump relay and Fan timer relay energized by thermostat. Fan speed relay is energized by fan switch in "HI" position. Water begins circulating on cooler pads, fan will start on high speed after short time delay.*
●				●	●	●		VENT MODE - Fan timer relay energized by thermostat. Fan speed relay is energized by fan switch in "HI" position. Fan will start on high speed after short time delay.*
	●			●	●			VENT MODE - Fan timer relay energized by thermostat. Fan will start on low speed after short time delay.*

- In "HI" position - No fan, but fan speed relay will remain energized
- Indicates switch position on thermostat subbase and system function in operation.

* Fan timer relay energizes in approximately one minute. When system shuts off, relay de-energizes in approximately 1/2 minute.

The Emerson logo is a trademark and a service mark of Emerson Electric Co.