



WHITE-RODGERS

1F90-71

5-Day/2-Day Electronic Digital Thermostat
INSTALLATION INSTRUCTIONS

Operator: Save these instructions for future use!

FAILURE TO READ AND FOLLOW ALL INSTRUCTIONS CAREFULLY BEFORE INSTALLING OR OPERATING THIS CONTROL COULD CAUSE PERSONAL INJURY AND/OR PROPERTY DAMAGE.

DESCRIPTION

This wall-mounted, low voltage thermostat maintains room temperature by controlling the operation of heating and cooling systems. The user may program up to four time/temperature settings per 24 hour period. The thermostat stores independent heating and cooling programs for 5-day (weekday) and 2-day (weekend) periods. The thermostat will store both heating and cooling programs simultaneously. Three "AA" Energizer® batteries will maintain the stored program for approximately one year, if incoming power should fail. If power failure is extensive and the program is lost, after power restoration, the thermostat will automatically maintain a factory preprogrammed heating temperature of 64°F or a cooling temperature of 82°F.

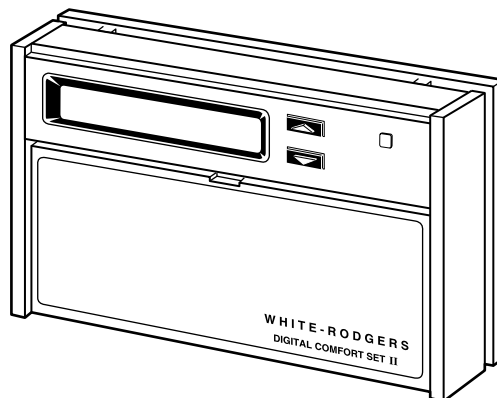

PRECAUTIONS

If in doubt about whether your wiring is millivolt, line, or low voltage, have it inspected by a qualified heating and air conditioning contractor, electrician, or someone familiar with basic electricity and wiring.

Do not exceed the specification ratings. All wiring must conform to local and national electrical codes and ordinances. This control is a precision instrument, and should be handled carefully. Rough handling or distorting components could cause the control to malfunction.

CONTENTS

Description	1
Precautions	1
Specifications	2
Installation	2
New Installation	
Select Thermostat Location	
Route Wires to Location	
Replacement Installation	
Remove Old Thermostat	
Attach Subbase to Wall	
Attach Thermostat to Subbase	
Operation	6
System Configuration	
A. Set Group A Option Switches	
B. Set Group B Option Switches	
C. Electric Heat Systems	
Check Thermostat Operation	
Fan Operation	
Heating System	
Cooling System	
Troubleshooting	

⚠ CAUTION

To prevent electrical shock and/or equipment damage, disconnect electric power to system, at main fuse or circuit breaker box, until installation is complete.

⚠ WARNING

Do not use on circuits exceeding specified voltage. Higher voltage will damage the control and could cause shock or fire hazard.
Do not short out terminals on gas valve or primary control to test. Short or incorrect wiring will burn out thermostat and could cause personal injury and/or property damage.



WHITE-RODGERS DIVISION
EMERSON ELECTRIC CO.
9797 REAVIS ROAD
ST. LOUIS, MISSOURI 63123-5398

Printed in U.S.A.

PART NO. 37-5086B
Replaces 37-5086A
9517

SPECIFICATIONS

ELECTRICAL DATA

Electrical Rating:

17 to 30 VAC, 50/60 Hz.

0.05 to 1.5 Amps

1.5 Amps Maximum Total Load (All terminals combined)

Anticipation:

Heating 2 to 40

Cooling 4 to 40

} **Reference Values**

THERMAL DATA

Setpoint Temperature Range:

40°F to 99°F (4°C to 37°C)

Operating Ambient Temperature Range:

32°F to 105°F

Operating Humidity Range:

0 to 90% RH (non-condensing)

Shipping Temperature Range:

-40°F to 150°F

APPLICATIONS

For use with:

- Standard heat/cool or heat-only systems
- Three-wire zone valve systems
- Millivolt systems
- Electric heat systems
- Gas or oil fired systems
- Gas systems with intermittent ignition devices (I.I.D.) and/or vent dampers

Do not use with:

- Multi-stage systems
- Heat pump systems
- Systems exceeding 30 VAC and 1.5 Amps

ACCESSORIES

Remote Sense Kit W. R. Part No. F145-1049

Thermostat Guard W. R. Part No. F29-0198 (clear) or F29-0238 (opaque)

INSTALLATION

NEW INSTALLATION

You should program the thermostat with batteries installed before attaching on subbase. See **OPERATION GUIDE** for programming instructions.

SELECT THERMOSTAT LOCATION

Proper location insures that the thermostat will provide a comfortable building temperature. Observe the following general rules when selecting a location:

1. Locate thermostat about 5 ft. above the floor.
2. Install thermostat on a partitioning wall, not on an outside wall.
3. Never expose thermostat to direct light from lamps, sun, fireplaces or any temperature radiating equipment.
4. Avoid locations close to windows, adjoining outside walls, or doors that lead outside.
5. Avoid locations close to air registers or in the direct path of air from them.
6. Make sure there are no pipes or duct work in that part of the wall chosen for the thermostat location.
7. Never locate thermostat in a room that normally warmer or cooler than the rest of the building.
8. Avoid locations with poor air circulation, such as behind doors or in alcoves.

ROUTE WIRES TO LOCATION

NOTE

All wiring must conform with local and national electrical codes and ordinances.

1. Probe for obstructions in partition before drilling 1/2" hole in wall at selected location. Take up quarter round and drill a small guide hole for sighting (see fig. 1). From basement, drill 3/4" hole in partition floor next to guide hole. In buildings without basements, drill 1/2" hole through ceiling and into partition from above.
2. Through this hole drop a light chain, or 6" chain attached to a strong cord. Snag cord in basement with hooked wire. In buildings without basements, drop cord through hole in ceiling and down partitioning; snag cord at the thermostat location.
3. Attach thermostat wire to cord and pull wire through hole in wall so that 6" of wire protrudes.

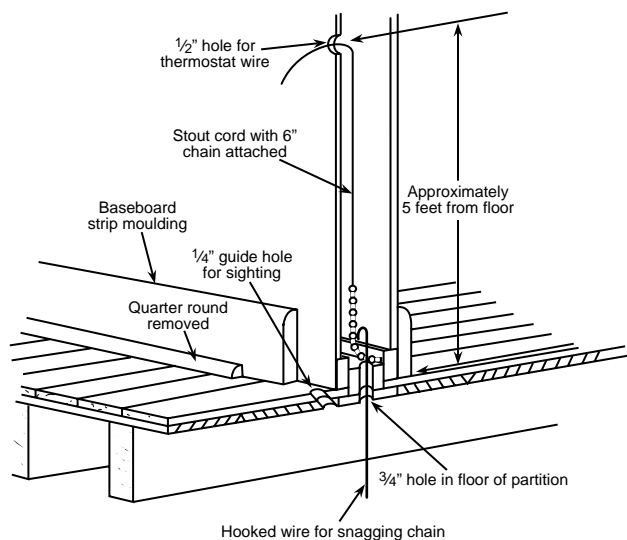

Figure 1. Routing thermostat wires

REPLACEMENT INSTALLATION

REMOVE OLD THERMOSTAT

1. Shut off electricity at the main fuse box until installation is complete. Verify power is off with a voltmeter.
2. Remove the front cover of the old thermostat. **With wires still attached**, remove wall plate from the wall.
3. If the old thermostat has a wall mounting plate, remove the thermostat and the wall mounting plate as an assembly.
4. **FOR HEATING ONLY SYSTEMS** — Disconnect the two wires from the old thermostat. Skip steps 5 through 7 below and proceed to **ATTACH SUBBASE TO WALL**.
5. **FOR HEATING/COOLING SYSTEMS** — Before removing wires from old thermostat, identify the terminals that have wires attached on the old thermostat. Then use Table 1 to identify the type of thermostat you are replacing. For example, if the old thermostat has wires attached to terminals R, W, Y, and G, the old thermostat is a type 5 (note that the old thermostat may not have wires attached to all the terminals identified in Table 1).
6. **Use the self-adhesive labels enclosed with your new thermostat to identify the wires attached to the old thermostat.** The labels correspond to the thermostat type number you identified in step 5 above (see Table 2). For example, if you determined that the old thermostat is a type 5, use the labels for the type 5 thermostat (you may not use all the labels for the type number you've identified if the old thermostat did not have wires attached to all the terminals).
7. Label each wire as you disconnect it. The labels have both the old terminal markings and the new terminal identification. Discard any unused labels. **PULL AT LEAST SIX INCHES OF WIRE OUT OF THE WALL WHEN YOU DISCONNECT IT - DO NOT ALLOW THE WIRES TO FALL BACK INTO THE WALL.**

ATTACH SUBBASE TO WALL

1. Remove the packing material from the thermostat. Place the fingers of one hand on the center top and bottom portion of the thermostat. Grasp the subbase in the other hand on the top and bottom center, and gently pull straight out (see fig. 2). The thermostat has pin and socket connectors. Forcing or prying on the thermostat will cause damage to the unit.
2. Pull wires through opening in the center of the subbase. **DO NOT LET WIRES FALL BACK INTO WALL.**
3. Connect wires beneath terminal screws on subbase using appropriate wiring schematic (see figs. 3 through 11).

(Installation instructions continue on page 5.)

TABLE 1. OLD THERMOSTAT IDENTIFICATION

OLD THERMOSTAT TYPE	OLD THERMOSTAT TERMINAL IDENTIFICATION				
	Terminal 1	Terminal 2	Terminal 3	Terminal 4	Terminal 5
Type 1	4	W	RC	Y	G
Type 2	RH	W	RC	Y	G
Type 3	M	H	V	C	F
Type 4	R5	4		Y6	G
Type 5	R	W		Y	G

TABLE 2. WIRE IDENTIFICATION LABELS

Type	New		Old		New		Old		New		Old	
	Terminal	Terminal	Terminal	Terminal	Terminal	Terminal	Terminal	Terminal	Terminal	Terminal	Terminal	Terminal
Type 1	RH	4	W	W	RC	RC	Y	Y	G	G		
Type 2	RH	RH	W	W	RC	RC	Y	Y	G	G		
Type 3	RH	M	W	H	RC	V	Y	C	G	F		
Type 4	RH	R5	W	4			Y	Y6	G	G		
Type 5	RH	R	W	W			Y	Y	G	G		

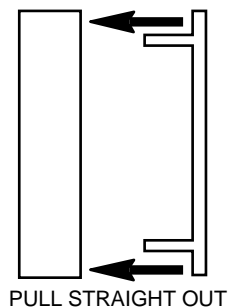

Figure 2. Removing thermostat from subbase

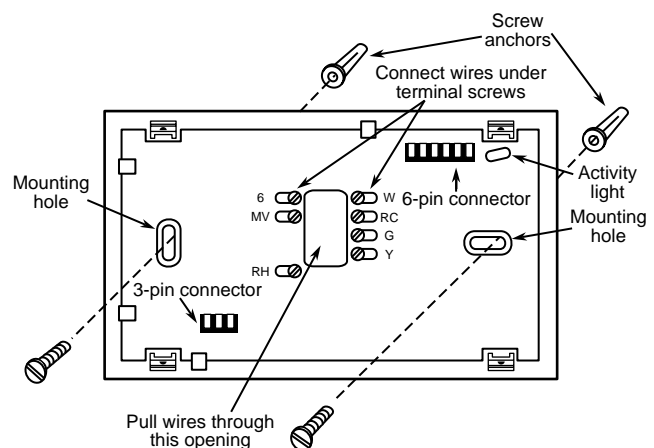

Figure 3. Subbase

NOTE

All wiring diagrams are for typical systems only. Refer to equipment manufacturers' instructions for specific system wiring information.

CAUTION

To prevent electrical shock and/or equipment damage, disconnect electrical power at the main fuse box or circuit breaker until installation is complete.

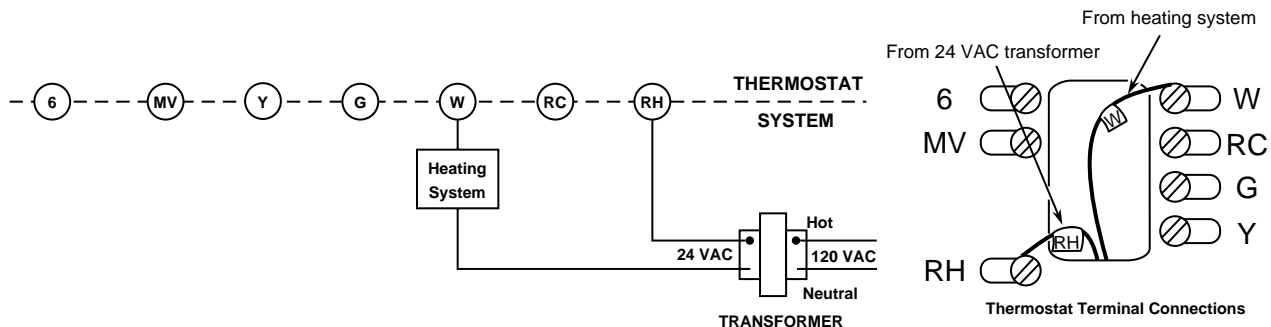

Figure 4. Typical wiring diagram for heat only, 2-wire, single transformer systems

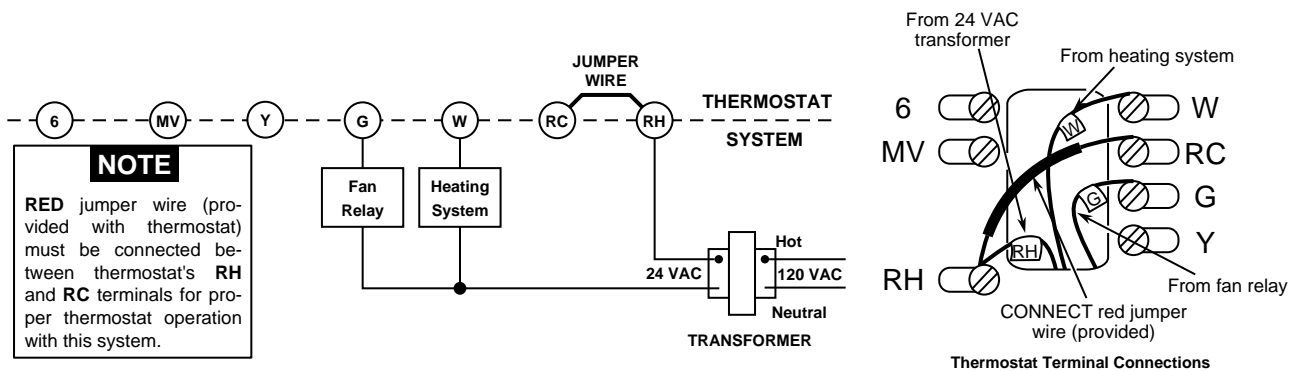

Figure 5. Typical wiring diagram for heat only, 3-wire, single transformer systems

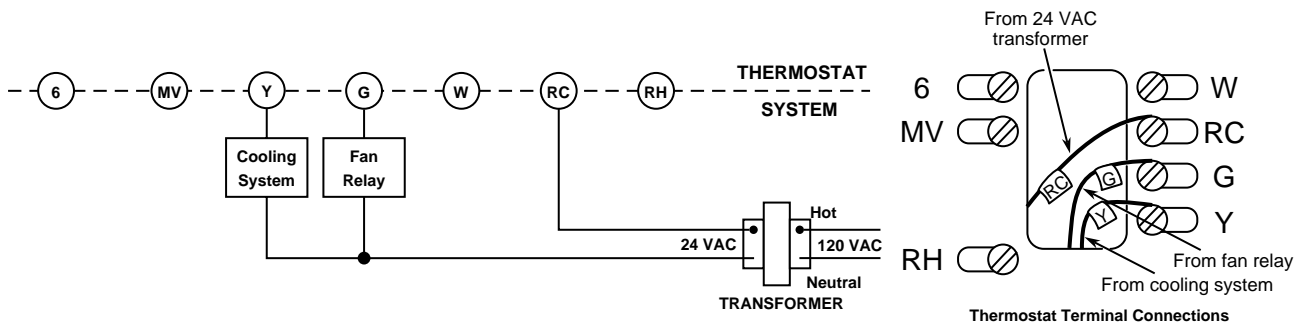

Figure 6. Typical wiring diagram for cool only, 3-wire, single transformer systems

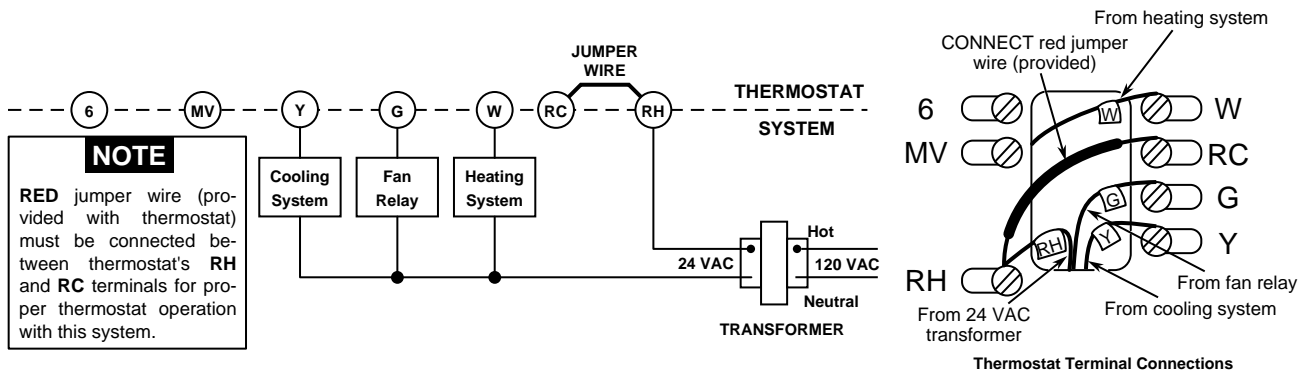

Figure 7. Typical wiring diagram for heat/cool, 4-wire, single transformer systems

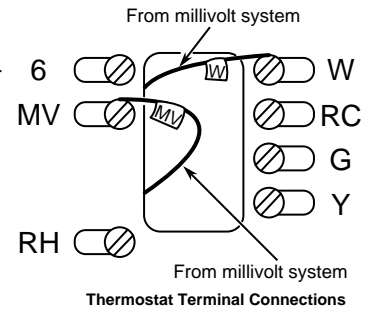
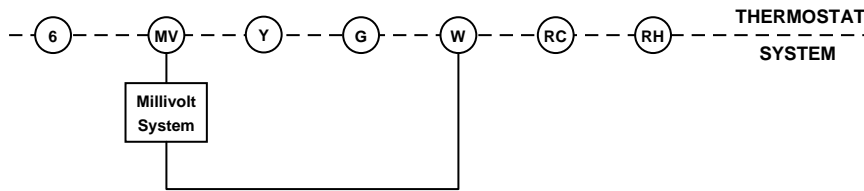

Figure 8. Typical wiring diagram for millivolt systems

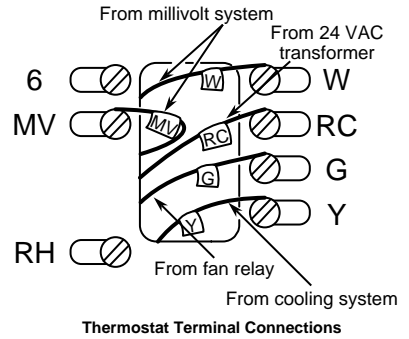
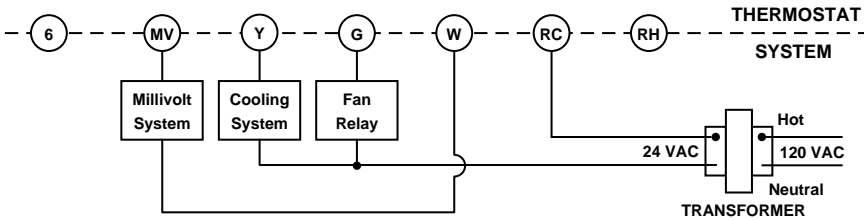

Figure 9. Typical wiring diagram for millivolt systems + cool only, 3-wire systems

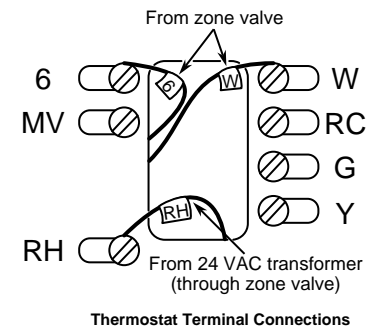
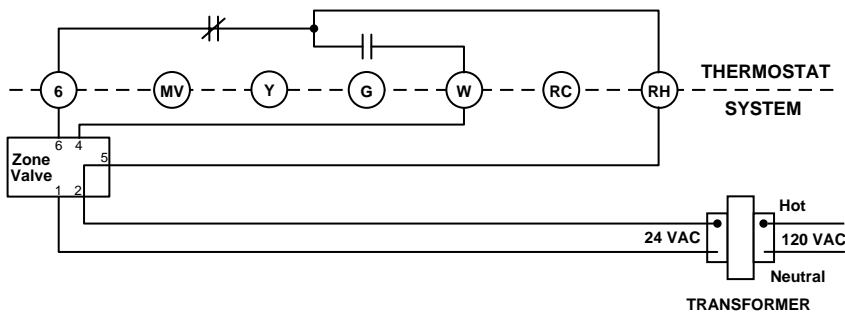

Figure 10. Typical wiring diagram for heat only, 3-wire, zone valve systems

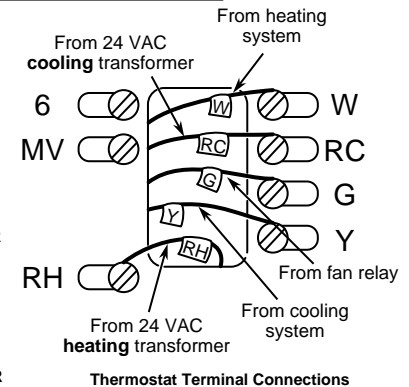
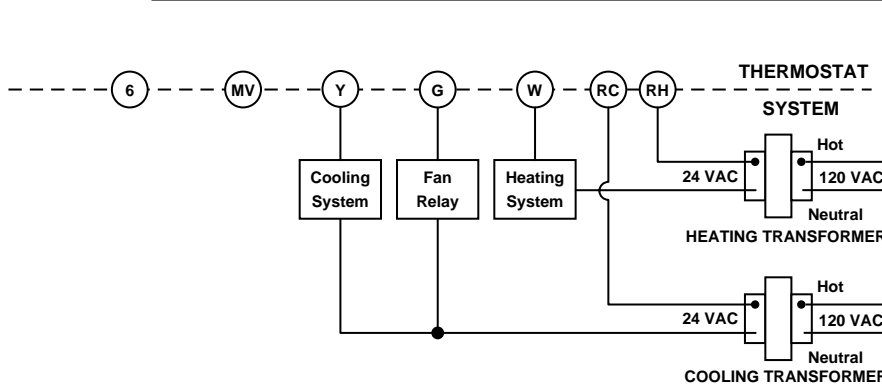



Figure 11. Typical wiring diagram for heat/cool, 5-wire, two-transformer system

4. Place subbase over hole in wall and mark mounting hole locations on wall using subbase as a template.
5. Move subbase out of the way. Drill mounting holes.
6. Fasten subbase loosely to wall, as shown in fig. 3, using two mounting screws. Place a level against bottom of subbase, adjust until level, and then tighten screws. (Leveling is for appearance only and will not affect thermostat operation.) If you are using existing
7. Push excess wire into wall and plug hole with a fire-resistant material (such as fiberglass insulation) to prevent drafts from affecting thermostat operation.

ATTACH THERMOSTAT TO SUBBASE

IT IS RECOMMENDED THAT YOU SET OPTION SWITCHES TO DESIRED POSITION BEFORE ATTACHING ON SUBBASE (see OPERATION). IT IS ALSO RECOMMENDED THAT YOU PROGRAM THE THERMOSTAT WITH BATTERIES INSTALLED BEFORE ATTACHING ON SUBBASE (see OPERATION GUIDE for programming instructions).

CAUTION

USE  TO TURN THERMOSTAT OFF BEFORE ATTACHING THERMOSTAT TO WALL. FAILURE TO TURN THERMOSTAT OFF BEFORE ATTACHING TO WALL MAY CAUSE EQUIPMENT DAMAGE DUE TO RAPID COMPRESSOR CYCLING.

To attach thermostat to subbase, line up the plastic snap guides at the bottom of the thermostat and the three connector pins on the thermostat with the connectors near the bottom left section of the subbase (when viewed

from the front). Gently pivot the thermostat up until the six pin connectors and the plastic snaps lock into place (see fig. 12). **Be gentle when attaching thermostat.** If the thermostat does not seem to be attaching to the subbase easily, make sure that the connector pins and plastic snaps are properly aligned, and that excess wire is pushed into the wall. **Damage to the thermostat may occur if force is used.**

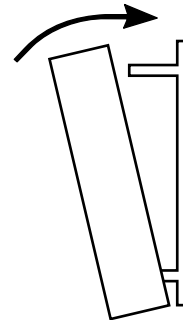

ENGAGE TWO LOWER GUIDES;
PIVOT UP

Figure 12. Attaching thermostat to subbase

OPERATION

SYSTEM CONFIGURATION

A. SET GROUP A OPTION SWITCHES

NOTE

DO NOT REMOVE THE "AA" BATTERIES WHEN CHANGING GROUP A OPTION SWITCHES. Any time Group B option switches are changed, the batteries must be removed for a minimum of two minutes.

1. Total Keypad Activity

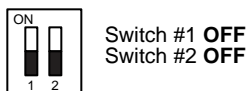

2. Total Keypad Lockout — All thermostat buttons are disabled.

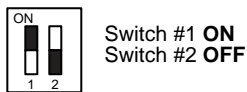

3. Limited Temperature Range — Temperature may be raised or lowered within programmed temperature limits (temperature adjustment cannot exceed the lowest cooling or highest heating program temperatures).

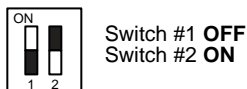

When thermostat is in **Limited Temperature Range** only the following buttons are disabled:

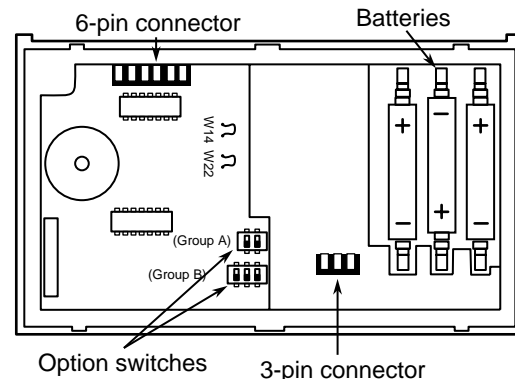

Figure 13. Back of thermostat

B. SET GROUP B OPTION SWITCHES

NOTE

ANY TIME GROUP B OPTION SWITCHES ARE CHANGED, THE "AA" BATTERIES MUST BE REMOVED FOR A MINIMUM OF 2 MINUTES. DO NOT REMOVE THE BATTERIES WHEN CHANGING GROUP A OPTION SWITCHES.

1. Automatic Changeover (Heating/Cooling Systems Only) — enables thermostat to automatically switch between heating and cooling programs to maintain desired room temperature.

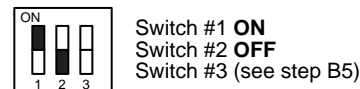

2. Manual Changeover (Heating/Cooling Systems Only)

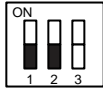

Switch #1 **OFF**
Switch #2 **OFF**
Switch #3 (see step B5)

3. Heat Only Systems

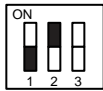

Switch #1 **OFF**
Switch #2 **ON**
Switch #3 (see step B5)

4. Cool Only Systems

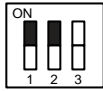

Switch #1 **ON**
Switch #2 **ON**
Switch #3 (see step B5)

5. Computed Energy Management Recovery (EMR) —

With EMR enabled, system will be energized **before** the next program period begins, to achieve programmed temperature by the beginning of the next program period (the thermostat's micro-computer calculates 15 minutes for every 2°F temperature change). For example, assume that the thermostat is programmed to provide an overnight heating temperature of 62°F, and during the next program period, programmed to begin at 6:00 AM, the programmed temperature is 70°F. With EMR activated, the thermostat will automatically activate the heating system at 5:00 AM, so that the programmed temperature of 70°F is reached by about 6:00 AM.

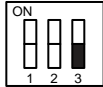

Switch #1 (see steps B1–B4)
Switch #2 (see steps B1–B4)
Switch #3 **OFF**

C. ELECTRIC HEAT SYSTEMS

For central electric heat systems where the blower is energized by a **separate circuit** through the fan relay (meaning that the fan turns on immediately on call for heat), clip wire **W14** on the back of the thermostat (see fig. 13). If the thermostat is energizing electric heat sequencers, **DO NOT** clip wire **W14**.

CHECK THERMOSTAT OPERATION

NOTE

When checking thermostat, Group B option switches #1 and #2 for automatic changeover must be in the **OFF** position. This will allow temporary setting of heat setpoints above cool setpoints. After system checkout, reset Group B option switch #1 to **ON** position if automatic changeover is desired (see **SET GROUP B OPTION SWITCHES**).

FAN OPERATION

1. Turn on power to the system. If the heat source has a standing pilot, be sure to light it.



2. Press  until **FAN ON** is displayed. The blower should begin to operate (this will work only on systems with a **G** terminal).

On three-wire heat only systems, or on four-wire heat/cool systems, if the thermostat display is operating properly, but the fan does not operate when 

is pressed, the red jumper wire (provided with thermostat) may not be properly installed between the **RH** and **RC** terminals. Disconnect electrical power to system and properly install the jumper wire per the appropriate wiring diagram.

3. Press  until **FAN AUTO** is displayed. The blower should stop operating within approximately one minute.

HEATING SYSTEM

1. Press  until **HEAT** is displayed (it may already be displayed).
2. Press  to adjust thermostat above room temperature to call for heat. The heating system should begin to operate.

(Instructions continue on next page.)

LOCKOUT BYPASS OPTION

FOR QUALIFIED SERVICE TECHNICIANS' USE ONLY. OPERATORS SHOULD NOT USE THIS FEATURE DUE TO POSSIBILITY OF EQUIPMENT OR PROPERTY DAMAGE, OR PERSONAL INJURY.

COMPRESSOR SHORT TERM CYCLE PROTECTION

This thermostat has a built-in short term (5-minute) time delay. During this 5-minute period, the thermostat will lock out the compressor to allow head pressure to stabilize. If you want to override this feature while testing thermostat operation, simply press 



and  buttons at the same time at initial startup.

DO NOT USE THE LOCKOUT BYPASS OPTION UNLESS THE COMPRESSOR OIL HEATERS HAVE BEEN OPERATIONAL FOR 6 HOURS AND THE SYSTEM HAS NOT BEEN OPERATIONAL FOR AT LEAST 5 MINUTES.

COOLING SYSTEM

CAUTION

To prevent compressor and/or property damage, if power to the compressor has been off or interrupted for more than 1 hour and the outdoor temperature is below 50°F, DO NOT operate the system for at least the amount of time the compressor was off! This will allow the compressor heaters to warm the compressor oils to avoid damage due to slugging.

1. Press  until **COOL** is displayed.
2. Press  to adjust thermostat below room temperature to call for cool. The blower should come on immediately, followed by cold air circulation. However, if the blower does not come on and the word **COOL** is flashing, the compressor lockout feature is operating (see **Lockout Bypass Option** to temporarily override the compressor lockout feature during testing).

If the thermostat display is operating properly, but the cooling system does not operate when the above steps are performed, the red jumper wire (provided with thermostat) may not be properly installed between the **RH** and **RC** terminals. Disconnect electrical power to system and properly install the jumper wire per the appropriate wiring diagram.

After the system has been checked and is running properly, determine if automatic changeover is desired (see **SYSTEM CONFIGURATION**).

Refer to the **OPERATION GUIDE** if you need additional information on thermostat operation.

TROUBLESHOOTING

Refer to the **Question & Answer** section of the **OPERATION GUIDE** for information on troubleshooting the thermostat.

If you need further information about this product, please write to:

WHITE-RODGERS
Division of Emerson Electric Co.
9797 Reavis Road
St. Louis, MO 63123-5398
ATTN: Technical Service Department
