

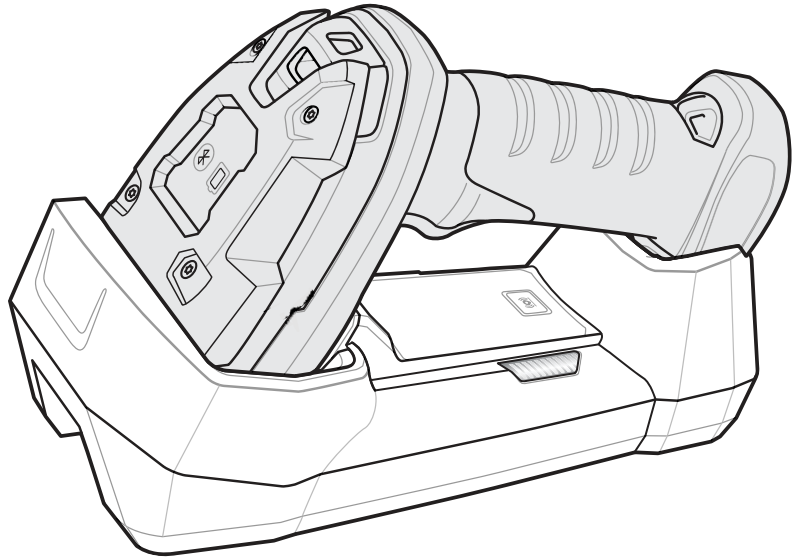

DS3678



Digital Scanner

Quick Start Guide

Zebra reserves the right to make changes to any product to improve reliability, function, or design.

Zebra does not assume any product liability arising out of, or in connection with, the application or use of any product, circuit, or application described herein. No license is granted, either expressly or by implication, estoppel, or otherwise under any patent right or patent, covering or relating to any combination, system, apparatus, machine, material, method, or process in which Zebra products might be used. An implied license exists only for equipment, circuits, and subsystems contained in Zebra products.

Warranty

For the complete Zebra hardware product warranty statement, go to: <http://www.zebra.com/warranty>.

For Australia Only

For Australia Only. This warranty is given by Zebra Technologies Asia Pacific Pte. Ltd., 71 Robinson Road, #05-02/03, Singapore 068895, Singapore. Our goods come with guarantees that cannot be excluded under the Australia Consumer Law. You are entitled to a replacement or refund for a major failure and compensation for any other reasonably foreseeable loss or damage. You are also entitled to have the goods repaired or replaced if the goods fail to be of acceptable quality and the failure does not amount to a major failure.

Zebra Technologies Corporation Australia's limited warranty above is in addition to any rights and remedies you may have under the Australian Consumer Law. If you have any queries, please call Zebra Technologies Corporation at +65 6858 0722. You may also visit our website: <http://www.zebra.com> for the most updated warranty terms.

Service Information

If you have a problem using the equipment, contact your facility's Technical or Systems Support. If there is a problem with the equipment, they will contact the Zebra Global Customer Support Center at: <http://www.zebra.com/support>.

For the latest version of this guide go to: <http://www.zebra.com/support>.

Introduction

The DS3678 cordless digital scanner combines excellent scanning performance and advanced ergonomics to provide the best value in a lightweight laser scanner, ensuring comfort and ease of use for extended periods of time.

Features

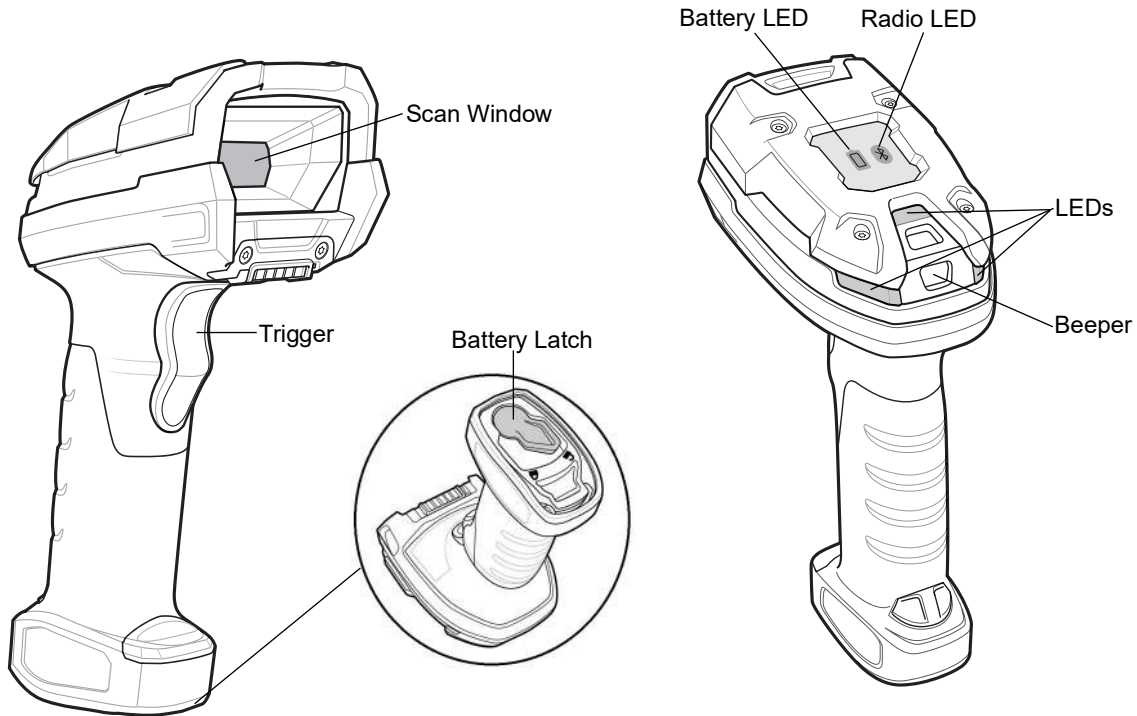

Battery Insertion/Removal

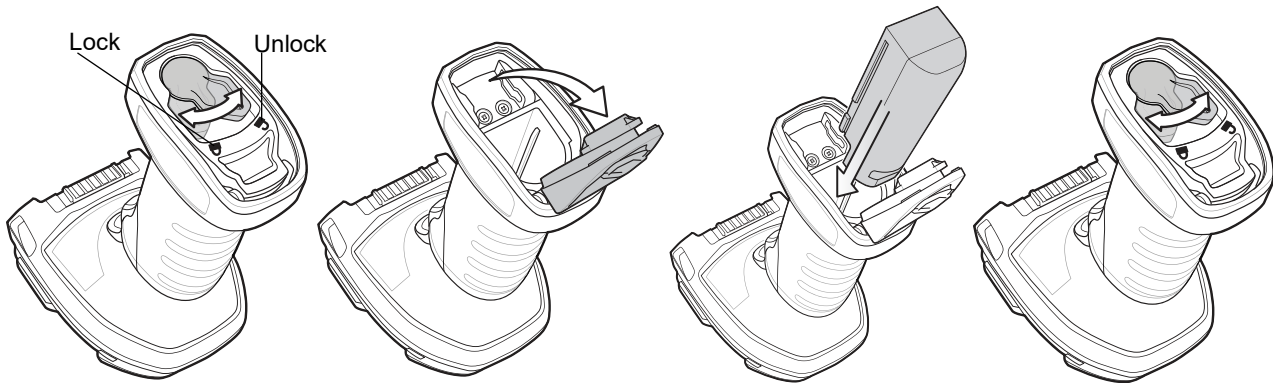

Cradle Cable Connection

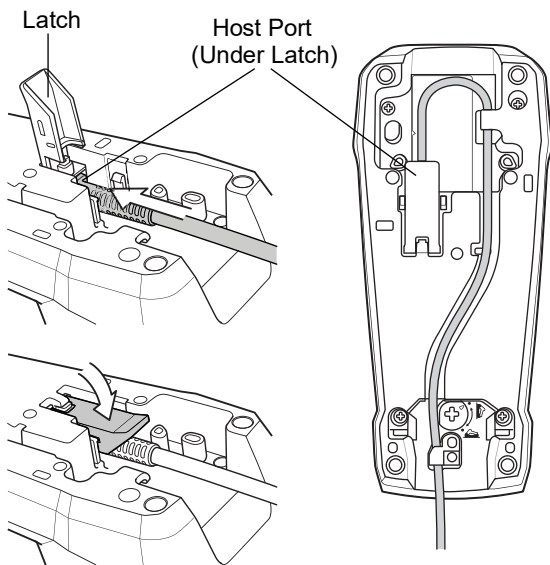

Cradle Insertion.

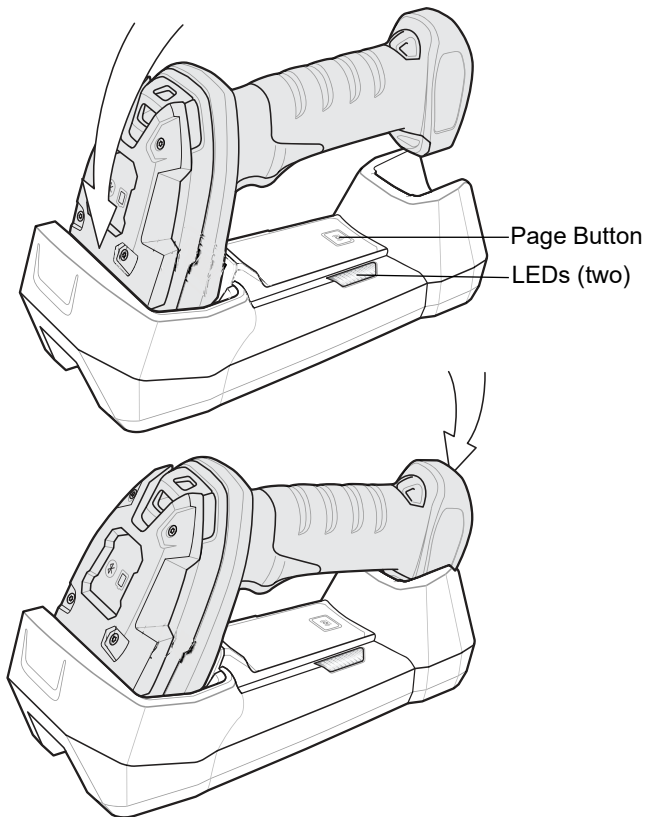

Host Interface Connections and Setup

USB

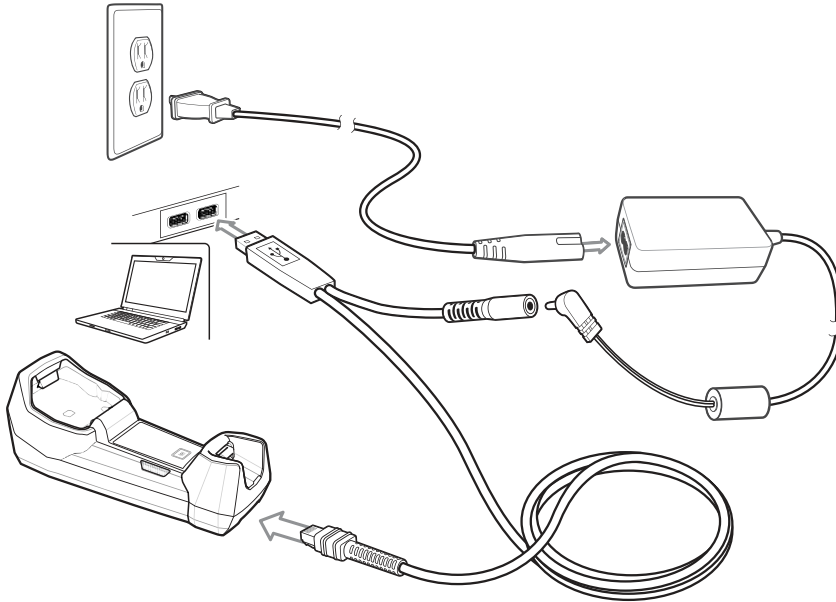

Scan one of the bar codes below

The interface cable automatically detects the host interface type and uses the default setting. If the default (*) does not meet your requirements, scan another host bar code below.



*USB KEYBOARD (HID)



USB CDC HOST

USB (continued)



IBM TABLE TOP USB



IBM HAND-HELD USB



SNAPi WITHOUT IMAGING



SNAPi WITH IMAGING



USB OPOS HAND-HELD



SSI OVER USB CDC



SIMPLE COM PORT EMULATION

RS-232

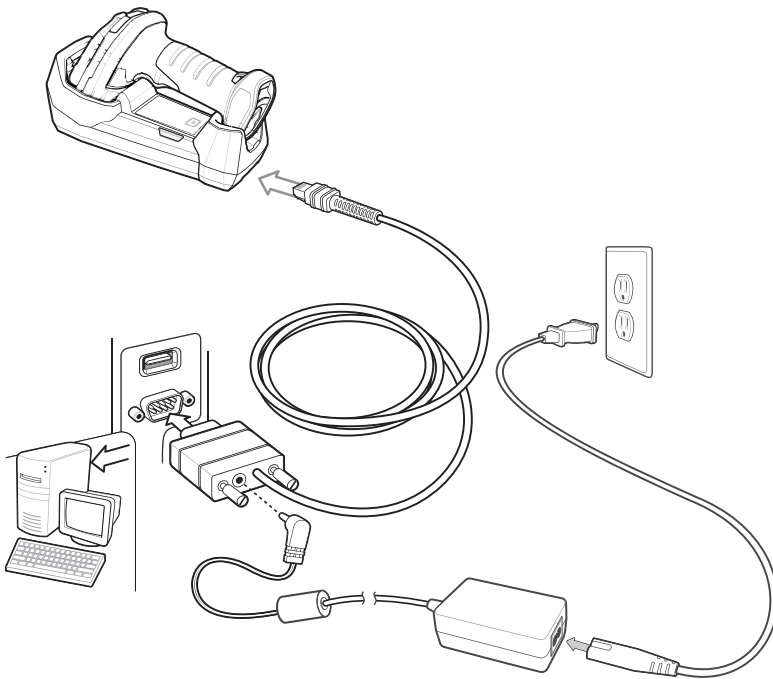

Scan one of the bar codes below

The interface automatically detects the host interface type and uses the default setting. If the default (*) does not meet your requirements, scan another host bar code below.



***STANDARD RS-232**



ICL RS-232



NIXDORF RS-232 MODE A



NIXDORF RS-232 MODE B

RS-232 (continued)



FUJITSU RS-232



OPOS/JPOS

Keyboard Wedge

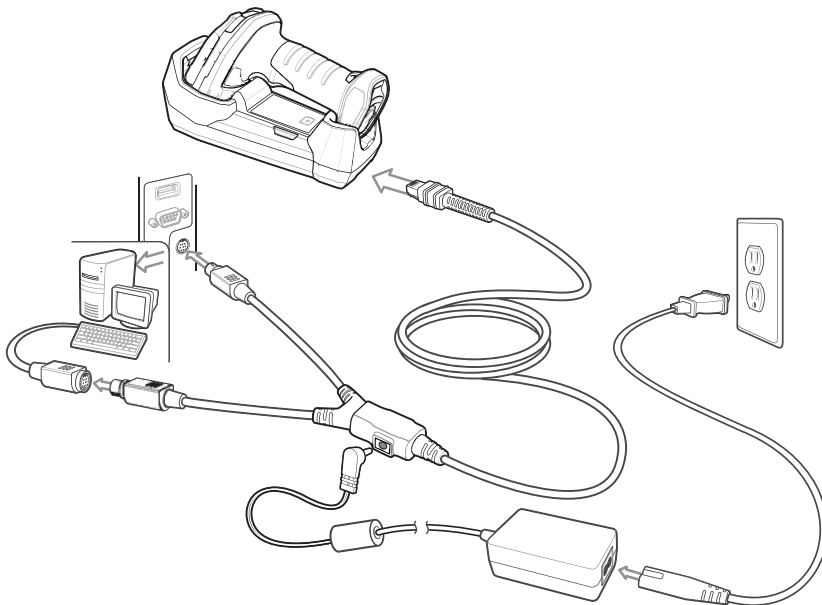

Scan a bar code below

The Auto-Host Detect Cable feature automatically detects the host interface type and uses the default setting. If the default (*) does not meet your requirements, scan the IBM PC/AT and IBM PC COMPATIBLE bar code below.



*IBM AT NOTEBOOK



IBM PC/AT and IBM PC COMPATIBLE

IBM 46XX

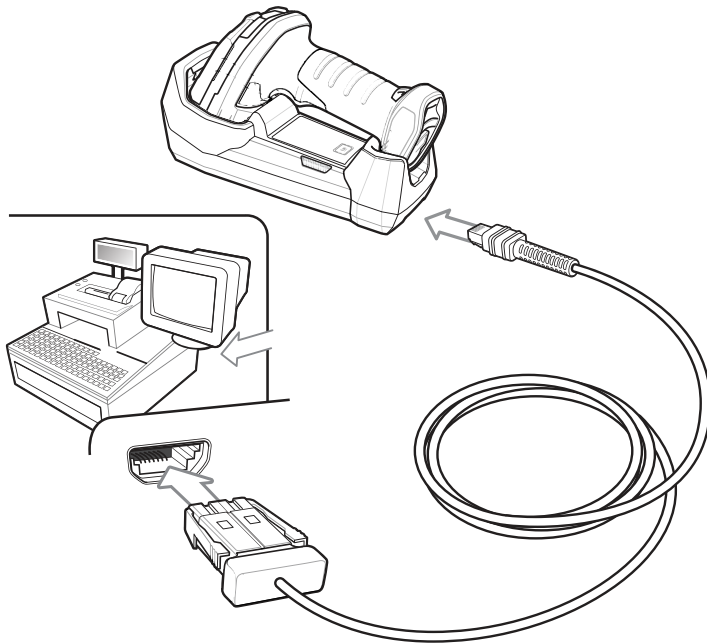

Scan one of the bar codes below

The Auto-Host Detect Cable feature automatically detects the host interface type, but there is no default setting. Scan one of the bar codes below to select the appropriate port.



NON-IBM SCANNER EMULATION (PORT 5B)



HAND-HELD SCANNER EMULATION (PORT 9B)



TABLE-TOP SCANNER EMULATION (PORT 17)

Set Defaults Bar Code



RETURN TO FACTORY DEFAULTS

Enter Key Bar Code (Carriage Return/Line Feed)

Add an Enter key after scanned data.

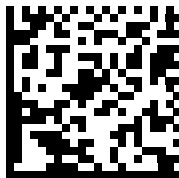

ADD AN ENTER KEY (CARRIAGE RETURN/LINE FEED)

Tab Key Bar Code

Add a Tab key after scanned data.

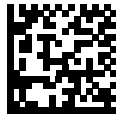

ADD A TAB KEY

USB Caps Lock Override



USB - OVERRIDE CAPS LOCK KEY (ENABLE)



*USB - DO NOT OVERRIDE CAPS LOCK KEY (DISABLE)

DS3678 Aiming

HP/HD/XR Aiming

Cover the entire bar code with the aiming pattern to ensure it is within the field of view.



SR Aiming

For best results, aim the aiming dot at the center of the bar code.



ER Aiming

Cover the entire bar code with the aiming pattern to ensure it is within the field of view.



DP Aiming

For best results, aim the aiming dot at the center of the bar code.



Recommended Usage -Optimum Body Posture

Avoid Extreme Wrist Angles



Avoid Bending



Avoid Reaching



LED Indications

Indication	LED
Hand-Held Scanning	
The scanner is on and ready to scan, or no power to the scanner	Off
A bar code is successfully decoded	Green
Transmission error	Red
Hand-Free (Presentation) Scanning	
No power to the scanner	Off
The scanner is on and ready to scan	Green
A bar code is successfully decoded	Off momentarily
Transmission error	Red

Beeper Indications

Indication	Beeper Sequence
Power up	Low/medium/high beep
A bar code is successfully decoded	Medium beep
Transmission error detected; data is ignored	4 long low beeps
Successful parameter setting	High/low/high/low beep
Correct programming sequence performed	High/low beep
Incorrect programming sequence, or Cancel bar code scanned	Low/high beep

✓ **NOTE** In addition to the System/Decode LEDs, the DS3678 cordless digital imager scanner has a Radio and Battery LED gauge. Refer to the *DS3678 Product Reference Guide* for detailed information.

Troubleshooting

Problem	Possible Causes	Possible Solutions
Scanner not working.	No power to scanner.	Check system power.
	Scanner is disabled.	Ensure that correct host interface cable is used.
Scanner decoding bar code, but data not transmitting to host.	Host interface not configured properly.	Scan appropriate host parameter bar codes.
	Interface cable is loose.	Ensure all cable connections are secure.
	Invalid ADF rule.	Program the correct ADF rules.
	Scanner not paired to cradle.	Scan cradle pairing bar code.
Scanner not decoding bar code.	Scanner not programmed for bar code type.	Ensure scanner is programmed to read type of bar code being scanned.
	Bar code unreadable.	Ensure bar code is not defaced; try scanning test bar code of same bar code type.
	Distance between scanner and bar code incorrect.	Move scanner closer to, or further from bar code.
Scanned data incorrectly displayed on host.	Host interface not configured properly.	Scan appropriate host parameter bar codes.
	Region improperly configured.	Select appropriate country and language encoding scheme.

123Scan²

123Scan2 is an easy-to-use, PC-based software tool that enables rapid and easy customized setup of a scanner via a bar code or USB cable. For more information, visit: <http://www.zebra.com/123Scan2>.

Regulatory Information

This device is approved under Zebra Technologies Corporation.

This guide applies to Model Number: DS3678.

All Zebra devices are designed to be compliant with rules and regulations in locations they are sold and will be labeled as required.

Local language translation / (BG) Превод на местен език / (CZ) Překlad do místního jazyka / (DE) Übersetzung in die Landessprache / (EL) Μετάφραση τοπικής γλώσσας / (ES) Traducción de idiomas locales / (ET) Kohaliku keele tõlge / (FI) Paikallinen käännös / (FR) Traduction en langue locale / (HR) Prijevod na lokalni jezik / (HU) Helyi nyelvű fordítás / (IT) Traduzione in lingua locale / (JA) 現地語翻訳 / (LT) Vietinės kalbos vertimas / (LV) Tulkojums vietējā valodā / (NL) Vertaling in lokale taal / (PL) Tłumaczenie na język lokalny / (PT) Tradução do idioma local / (RO) Traducere în limba locală / (RU) Перевод на местный язык / (SK) Preklad do miestneho jazyka / (SL) Prevajanje v lokalni jezik / (SR) Превод на локални језик / (SV) Översättning av lokalt språk / (TR) Yerel dil çevirisi / (ZH-CN) 当地语言翻译 / (ZH-TW) 當地語言翻譯 / zebra.com/support.

Any changes or modifications to Zebra equipment, not expressly approved by Zebra, could void the user's authority to operate the equipment.



CAUTION Only use Zebra approved and UL Listed accessories, battery packs, and battery chargers.

Do NOT attempt to charge damp/wet mobile computers or batteries. All components must be dry before connecting to an external power source.

DS3678 Declared maximum operating temperature: 50°C

Declared maximum operating temperature when used with FLB3678 50°C / STB3678 40°C

Bluetooth® Wireless Technology

This is an approved Bluetooth® product. For more information or to view the End Product Listing, please visit <https://www.bluetooth.org/tpg/listings.cfm>.

Regulatory Markings

Regulatory markings subject to certification are applied to the device signifying the radio(s) is/are approved for use. Refer to the Declaration of Conformity (DoC) for details of other country markings. The DOC is available at: zebra.com/doc.

Health and Safety Recommendations

Ergonomic Recommendations

In order to avoid or minimize the potential risk of ergonomic injury, always follow good ergonomic workplace practices. Consult with your local Health and Safety Manager to ensure that you are adhering to your company's safety programs to prevent employee injury.

Vehicle Installation

RF signals may affect improperly installed or inadequately shielded electronic systems in motor vehicles (including safety systems). Check with the manufacturer or its representative regarding your vehicle. Ensure the equipment is installed to avoid driver distractions. You should also consult the manufacturer about any equipment that has been added to your vehicle.

Position the device within easy reach. User should be able to access the device without removing their eyes from the road.



IMPORTANT: Before installing or using, check national and local laws regarding distracted driving.

Restricted Use Locations

Remember to observe restrictions and obey all signs and instructions on the use of electronic devices in restricted use locations.

Safety in Hospitals and Aircraft



Wireless devices transmit radio frequency energy that may affect medical electrical equipment and aircraft's operation. Wireless devices should be switched off wherever you are requested to do so in hospitals, clinics, healthcare facilities or by airline staff. These requests are designed to prevent possible interference with sensitive equipments.

RF Exposure Guidelines



Safety Information

Reducing RF Exposure – Use Properly

Only operate the device in accordance with the instructions supplied.

The device complies with internationally recognized standards covering human exposure to electromagnetic fields. For information on international human exposure to electromagnetic fields, refer to the Zebra Declaration of Conformity (DoC) at zebra.com/doc.

Use only Zebra tested and approved headset, belt-clips, holsters, and similar accessories to ensure RF exposure compliance. If applicable, follow the instructions for use as detailed in the accessory guide.

The use of third-party belt clips, holsters, and similar accessories may not comply with RF exposure compliance requirements and should be avoided.

For further information on the safety of RF energy from wireless devices, refer to RF exposure and assessment standards section at zebra.com/responsibility

To satisfy RF exposure requirements, this device must be hand-held only and, where applicable use only with Zebra tested and approved accessories.

Optical Devices



Laser

Class 2 laser scanners use a low power, visible light diode. As with any very bright light source such as the sun, the user should avoid staring directly into the light beam. Momentary exposure to a Class 2 laser is not known to be harmful.



CAUTION: Use of controls, adjustments, or the performance of procedures other than those specified in the supplied product documentation may result in hazardous laser light exposure.

SE5800 Wavelength: 500-570 nm
 Maximum output: 2 mW
 Pulse duration: 4 ms
 Beam divergence: 42 °
 Repetition rate: 16.7 ms

Scanner Labeling

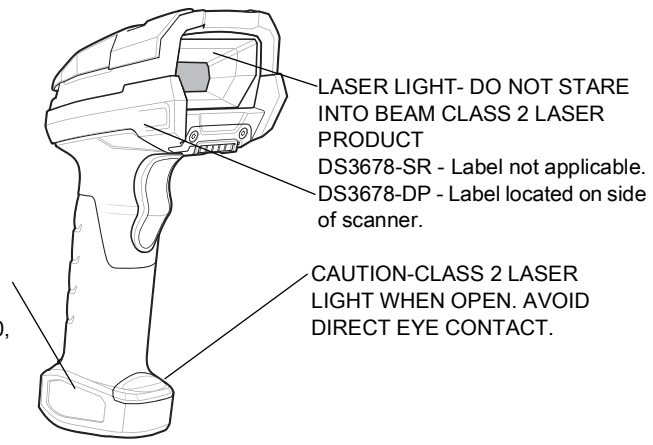

LASER LIGHT- DO NOT STARE INTO BEAM CLASS 2 LASER PRODUCT
 DS3678-SR - Label not applicable.
 DS3678-DP - Label located on side of scanner.

CAUTION-CLASS 2 LASER LIGHT WHEN OPEN. AVOID DIRECT EYE CONTACT.

COMPLIES WITH 21 CFR1040.10 AND 1040.11 EXCEPT FOR DEVIATIONS PURSUANT TO LASER NOTICE NO. 50, DATED JUNE 24, 2007, AND IEC/EN 60825-1:2007 and/or IEC/EN 60825-1:2014

DS3678-SR LED - Exempt Risk Group
 DS3678-ER Class 2
 DS3678-HP Class 2
 DS3678-HD Class 2
 DS3678-DP Class 2
 DS3678-XR Class 2

Labels read:

Laser Light — do not stare into beam.

1. Class 2 Laser product. 630-680nm, 1mW (applied to ds3678)
2. Complies with 21 CFR1040.10 and 1040.11 except for deviations pursuant to Laser Notice No. 56, dated May 08, 2019 and IEC/EN 60825-1:2014.

LED

Risk Group classified according to IEC 62471:2006 and EN62471:2008.

- SE5800 Pulse Duration: 6 ms
- RG0

Batteries and Power Packs

This information applies to Zebra-approved batteries and power packs containing batteries.

Battery Information



CAUTION: Risk of explosion if battery is replaced by an incorrect type. Dispose of batteries according to instructions.

Use only Zebra approved batteries. Accessories which have battery charging capability are approved for use with the following battery models:

- Model 82-166537-01 (3.6 VDC, 3150 mAh)

Zebra approved rechargeable battery packs are designed and constructed to the highest standards within the industry.

However, there are limitations as to how long a battery can operate or be stored before needing replacement. Many factors affect the actual life cycle of a battery pack such as heat, cold, harsh environmental conditions, and severe drops.

When batteries are stored over six months, some irreversible deterioration in overall battery quality may occur. Store batteries at half charge in a dry, cool place, removed from the equipment to prevent loss of capacity, rusting of metallic parts, and electrolyte leakage. When storing batteries for one year or longer, the charge level should be verified at least once a year and charged to half charge.

Replace the battery when a significant loss of run time is detected.

- Standard warranty period for all Zebra batteries is one year, regardless if the battery was purchased separately or included as part of the host device. For more information on Zebra batteries, please visit: zebra.com/batterydocumentation and select the Battery Best Practices link.

Battery Safety Guidelines



IMPORTANT – SAFETY INSTRUCTIONS – SAVE THESE INSTRUCTIONS



WARNING – When using this product basic safety precautions should always be followed, including the following:

The area in which the units are charged should be clear of debris and combustible materials or chemicals. Particular care should be taken where the device is charged in a non-commercial environment.

- Read all the instructions before using the product.
- Follow battery usage, storage, and charging guidelines found in the user's guide.
- Improper battery use may result in a fire, explosion, or other hazard.
- Batteries subjected to extremely low air pressure may result in an explosion or the leakage of flammable liquid or gas.

To charge the mobile device battery, the battery and charger temperatures must be between 0°C and 40°C (32°F and 104°F).

Do not use incompatible batteries and chargers. Use of an incompatible battery or charger may present a risk of fire, explosion, leakage, or other hazard. If you have any questions about the compatibility of a battery or a charger, contact Zebra support.

For devices that utilize a USB port as a charging source, the device shall only be connected to products that bear the USB-IF logo or have completed the USB-IF compliance program.

Do not disassemble or open, crush, bend or deform, puncture, or shred. Damaged or modified batteries may exhibit unpredictable behavior resulting in fire, explosion, or risk of injury.

Severe impact from dropping any battery-operated device on a hard surface could cause the battery to overheat.

Do not short circuit a battery or allow metallic or conductive objects to contact the battery terminals.

Do not modify, disassemble, or remanufacture, attempt to insert foreign objects into the battery, immerse or expose to water, rain, snow or other liquids, or expose to fire, explosion, or other hazard.

Do not leave or store the equipment in or near areas that might get very hot, such as in a parked vehicle or near a radiator or other heat source. Do not place battery into a microwave oven or dryer.

To reduce the risk of injury, close supervision is necessary when used near children.

Please follow local regulations to promptly dispose of used re-chargeable batteries.

Do not dispose of batteries in fire. Exposure to temperatures over 100°C (212°F) may cause explosion.

Seek medical advice immediately if a battery has been swallowed.

In the event of a battery leak, do not allow the liquid to come in contact with the skin or eyes. If contact has been made, wash the affected area with large amounts of water and seek medical advice.

If you suspect damage to your equipment or battery, contact Zebra support to arrange for inspection.

Do not use a power pack in excess of its output rating. Overload outputs may result in risk of fire or injury to persons.

Have service performed by a qualified Zebra service center. This will insure safety of the product is maintained.

Switch off the power pack when not in use.

Marking and European Economic Area (EEA)

Statement of Compliance

Zebra hereby declares that this radio equipment is in compliance with Directives 2014/53/EU and 2011/65/EU.

Any radio operation limitations within EEA countries are identified in Appendix A of EU Declaration of Conformity. The full text of the EU Declaration of Conformity is available at: zebra.com/doc.

EU Importer : Zebra Technologies B.V

Address: Mercurius 12, 8448 GX Heerenveen, Netherlands

Waste Electrical and Electronic Equipment (WEEE)

For EU and UK Customers: For products at the end of their life, please refer to recycling/disposal advice at: zebra.com/weee.

United States and Canada Regulatory

Radio Frequency Interference Notices

This device complies with Part 15 of the FCC Rules. Operation is subject to the following two conditions: (1) this device may not cause harmful interference, and (2) this device must accept any interference received including interference that may cause undesired operation.



NOTE: This equipment has been tested and found to comply with the limits for a Class B digital device, pursuant to Part 15 of the FCC rules. These limits are designed to provide reasonable protection against harmful interference in a residential installation. This equipment generates, uses and can radiate radio frequency energy and, if not installed and used in accordance with the instructions, may cause harmful interference to radio communications. However, there is no guarantee that interference will not occur in a particular installation. If this equipment does cause harmful interference to radio or television reception, which can be determined by turning the equipment off and on, the user is encouraged to try to correct the interference by one or more of the following measures:

- Reorient or relocate the receiving antenna.
- Increase the separation between the equipment and receiver.
- Connect the equipment into an outlet on a circuit different from that to which the receiver is connected.
- Consult the dealer or an experienced radio/TV technician for help.

Radio Frequency Interference Requirements – Canada

Innovation, Science and Economic Development Canada ICES-003 Compliance Label: CAN ICES-003 B/NMB-003 B

This device complies with Innovation, Science and Economic Development Canada's licence-exempt RSSs. Operation is subject to the following two conditions: (1) This device may not cause interference; and (2) This device must accept any interference, including interference that may cause undesired operation of the device.

L'émetteur/récepteur exempt de licence contenu dans le présent appareil est conforme aux CNR d'Innovation, Sciences et Développement économique Canada applicables aux appareils radio exempts de licence. L'exploitation est autorisée aux deux conditions suivantes : (1) l'appareil ne doit pas produire de brouillage, et (2) l'utilisateur de l'appareil doit accepter tout brouillage radio électrique subi même si le brouillage est susceptible d'en compromettre le fonctionnement.

This device is restricted to indoor use when operating in the 5150 to 5350 MHz frequency range.

Lorsqu'il fonctionne dans la plage de fréquences 5 150- 5350 MHz, cet appareil doit être utilisé exclusivement en extérieur.

RF Exposure Requirements - FCC and ISED

The FCC has granted an Equipment Authorization for this device with all reported SAR levels evaluated in compliance with the FCC RF emission guidelines. SAR information on this device is on file with the FCC and can be found under the Display Grant section of www.fcc.gov/oet/ea/fccid.

To satisfy RF exposure requirements, this device must be hand-held only and, where applicable use only with Zebra tested and approved accessories.

Pour être conforme à la réglementation relative à l'exposition RF, cet appareil doit être uniquement porté au poignet ou à la cheville et, lorsque cela est applicable, utilisé uniquement avec des accessoires testés et approuvés par Zebra.

Co-located Statement

To comply with FCC RF exposure compliance requirement, the antenna used for this transmitter must not be co-located (within 20 cm) or operating in conjunction with any other transmitter/antenna except those already approved in this filing.

日本 (Japan)



このデバイスと一緒に販売されている充電式バッテリーには、回収、処理、リサイクルできる貴重な金属やその他の素材が含まれています。充電式バッテリーパックを安全に廃棄する方法については、最寄りのリサイクルセンターにお問い合わせください。

中国 (China)

通过访问以下网址可下载当地语言支持的产品说明书 www.zebra.com/support



产品中有害物质的名称及含量

This table was created to comply with China RoHS requirements.

部件名称 (Parts)	有害物质 					
	铅 (Pb)	汞 (Hg)	镉 (Cd)	六价铬 (Cr (VI))	多溴联苯 (PBB)	多溴二苯醚 (PBDE)
金属部件 (Metal Parts)	X	○	○	○	○	○
电路模块 (Circuit Modules)	X	○	○	○	○	○
电缆及电缆组件 (Cables and Cable Assemblies)	○	○	○	○	○	○
塑料和聚合物部件 (Plastic and Polymeric Parts)	○	○	○	○	○	○
光学和光学组件 (Optics and Optical Components)	X	○	○	○	○	○
电池 (Batteries)	○	○	○	○	○	○

本表格依据SJ/T 11364 的规定编制。

- 0: 表示该有害物质在该部件所有均质材料中的含量均在 SJ/T 11364—2014 规定的限量要求以下。
 X: 表示该有害物质至少在该部件的某一均质材料中的含量超出 SJ/T 11364—2014 规定的限量要求。(企业可在此处, 根据实际情况对上表中打“×”的技术原因进行进一步说明。)

This table was created to comply with China RoHS requirements.

Евразийский Таможенный Союз (EAC)

Translation: This product complies with the requirements of the EAC mark.

Данный продукт соответствует требованиям знака EAC.



臺灣

公司資訊

台灣斑馬科技股份有限公司 / 台北市信義區松高路 9 號 13 樓



行政院環保署 (EPA) 要求乾電池製造或進口商，需依廢棄物清理法第 15 條之規定，於販售、贈送或促銷的電池上標示回收標誌。請聯絡合格的台灣回收廠商，以正確棄置電池。

限用物質含有情況標示聲明書

掃描器		型號 (型式) DS3678				
單元 Unit	限用物質及其化學符號 Restricted substances and its chemical symbols					
	鉛 (Pb)	汞 (Hg)	鎘 (Cd)	六價鉻 (Cr+6)	多溴聯苯 (PBB)	多溴二苯醚 (PBDE)
印刷電路板及電子組件	—	○	○	○	○	○
金屬零件	—	○	○	○	○	○
電纜及電纜組件	○	○	○	○	○	○
塑料和聚合物零件	○	○	○	○	○	○
光學與光學元件 —	—	○	○	○	○	○
打印頭	○	○	○	○	○	○

備考 1. “超出 0.1 wt %” 及 “超出 0.01 wt %” 係指限用物質之百分比含量超出百分比含量基準值。
備考 2. “○” 係指該項限用物質之百分比含量未超出百分比含量基準值。
備考 3. “—” 係指該項限用物質為排除項目。

Note 1: “Exceeding 0.1 wt%” and “exceeding 0.01 wt%” indicate that the percentage content of the restricted substance exceeds the reference percentage value of presence condition.
Note 2: “○” indicates that the percentage content of the restricted substance does not exceed the percentage of reference value of presence.
Note 3: The “—” indicates that the restricted substance corresponds to the exemption.

TÜRK WEEE Uyumluluk Beyanı

EEE Yönetmeliğine Uygundur.



Statement of Compliance

Zebra hereby declares that this radio equipment is in compliance with the Radio Equipment Regulations 2017 and the Restriction of the Use of Certain Hazardous Substances in Electrical and Electronic Equipment Regulations 2012.

Any radio operation limitations within UK are identified in Appendix A of UK Declaration of Conformity.

The full text of the UK Declaration of Conformity is available at: zebra.com/doc.

UK Importer: Zebra Technologies Europe Limited

Address:

Dukes Meadow, Millboard Rd, Bourne End, Buckinghamshire, SL8 5XF



Zebra Technologies Corporation
Lincolnshire, IL U.S.A.
www.zebra.com

© 2024 ZIH Corp and/or its affiliates. All rights reserved. ZEBRA and the stylized Zebra head are trademarks of ZIH Corp, registered in many jurisdictions worldwide. All other trademarks are the property of their respective owners.

MN002648A04EN Revision A- February 2024

